

Centurion University of Technology & Management

The world of hopes & possibilities

February 2022

Centurion University





Centurion
UNIVERSITY

Odisha's first Private State University with NAAC 'A' Grade & UGC 12(b) status and govt. notified Skills University & MSDE notified Center of Excellence

Operates 10 schools across 5 constituent campuses in Odisha & AP. Has a **School of Vocational Training** is incorporated in the act, to underline its commitment towards skill development & vocational education & provide additional impetus to its partnership with NSDC

Gram Tarang group of companies: Incubated social entrepreneurial outreach entities

Incubated in largely underdeveloped regions of the country solving for the problems of skilling at the bottom of the pyramid, providing financial & banking services to unbanked villages, manufacturing, design & engineering services and agri & other farm products



www.gramtarang.in

CENTURION UNIVERSITY: MISSION, VISION, VALUES

MISSION

“To be an accredited human resource hub of excellence for catalyzing sustainable livelihoods in challenging geographies”

VISION

Converging education with employability, employment, and entrepreneurship through lighthouse projects, real time products, and appropriate and relevant skilling and application of technology

VALUES

Inclusivity, equity, equality in economic, environmental, educational sustenance

1

The Centurion- Gram Tarang model

How we built an inclusive integrated
model of skill development



Key Milestones of CUTM's skilling journey



State enacted University with NAAC 'A' Grade
27-Aug-2010

Odisha's first Skills University
30-Aug-2017

MSDE's Awarding body for Short Term skilling
27-Nov-2018

MSDE's first Center of Excellence
18-Nov-2019

First Educational Institute to secure SGSY project in 2010; First NSDC partner

NSDC, FICCI awards, recognitions, UN citations & Skills University status

Empaneled by different states for skill assessments & certifications

Teaching, Training Production model given recognition by MSDE



Enacted in 2010, CUTM was declared to be Odisha's first & only Skills University in 2017; Declared MSDE's first Center of Excellence and Awarding Body

Institutional model with Industry, Academia, Government & Social entrepreneurship

- Policy, standards, funding through various schemes, governance;
- Credibility & outreach for mobilization

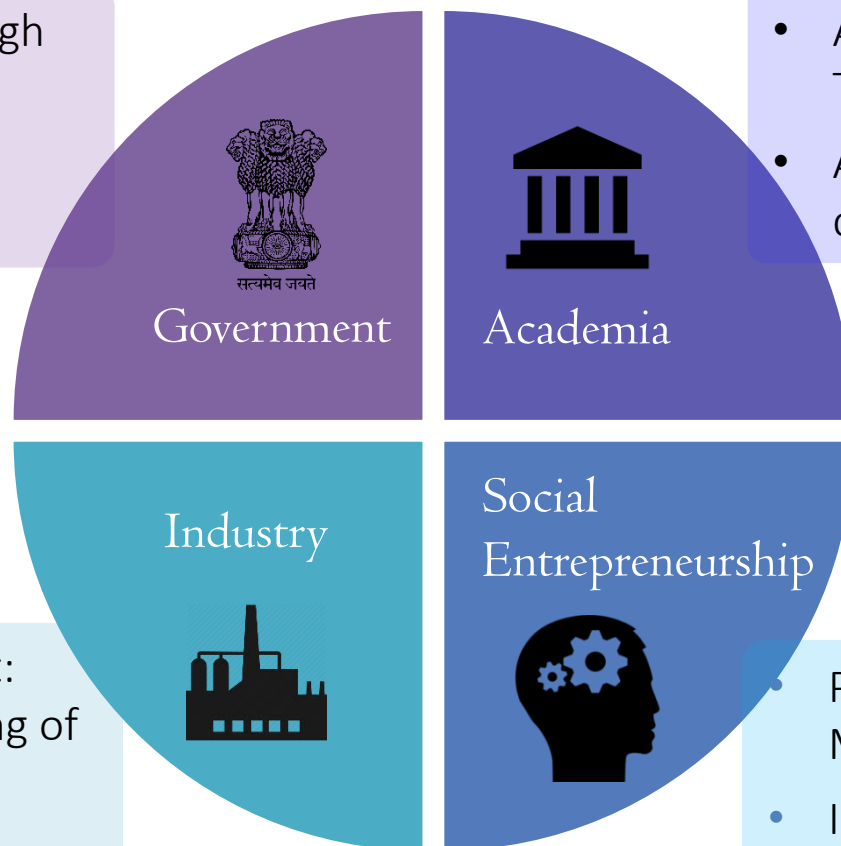

- Academic rigor through curriculum, Trainers, faculty
- Assessments, Certifications & qualifications for higher education



- Technical & knowledge support: equipment, curriculum, Training of trainers
- OJT & employment opportunity

- Program Implementation, Mobilization,
- Industry connect, Placements, post placements support

An integrated ecosystem focused on building competencies & skills

Community outreach through incubation & social entrepreneurship



CUTM Center for Innovators & Entrepreneurs

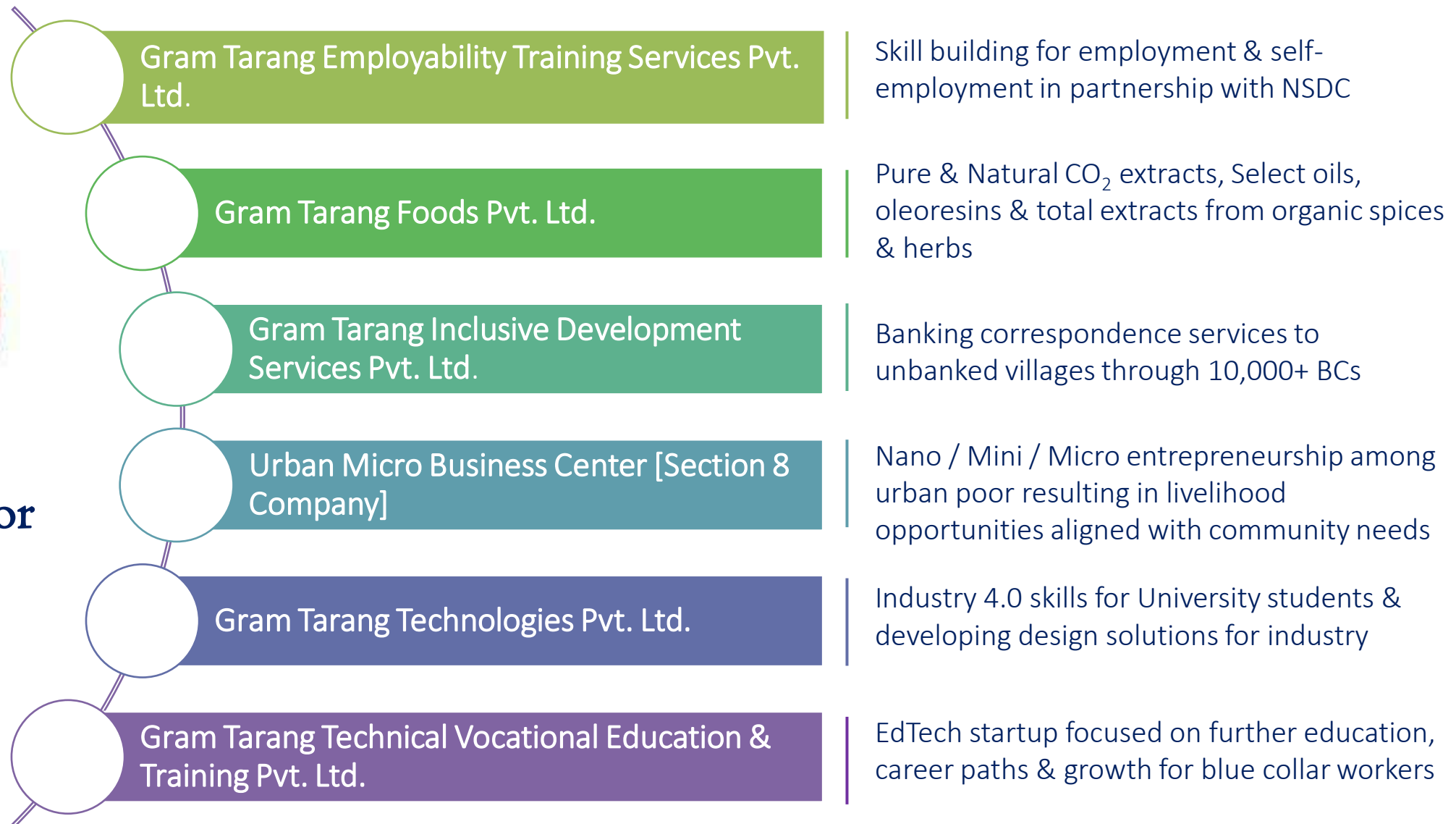

Building best in class training infrastructure



...with a sectoral focus & extensive industry integration...

1 Automotive



2 Manufacturing & Energy



3 Agriculture



4 Hospitality



5 Healthcare



GE Healthcare



... innovative industry ready programs

3D Design, VR,
Gaming



- Training in 3D software across 55 colleges of AP
- 25,000 enrolled to date; To be extended to Gaming

Automotive



- Advanced automotive training in electronic diagnostic tools relevant for BS VI

Ramadevi
Women's
University &
CBSE



- Integrating Skills with Higher education & school education
- Trainer Qualifications Framework

Healthcare

GE Healthcare



- Paid model for OT/AT & XR Technicians in AP
- Long term courses linked with Manipal Hospitals

...in 8 states across the country...

OUR PRESENCE
- 9 States | 35 Centers
- 300,000 trainees enrolled to date
- 70% eligible candidates placed

Odisha: 18 Centers

Assam, Meghalaya: 4 centers

NCR, UP, Jharkhand: 1 Center each

Punjab: 2 centers

Destinations: 7 centers

MP, Maharashtra, Rajasthan, Haryana,

Delhi, Chhattisgarh: NSQF Schools

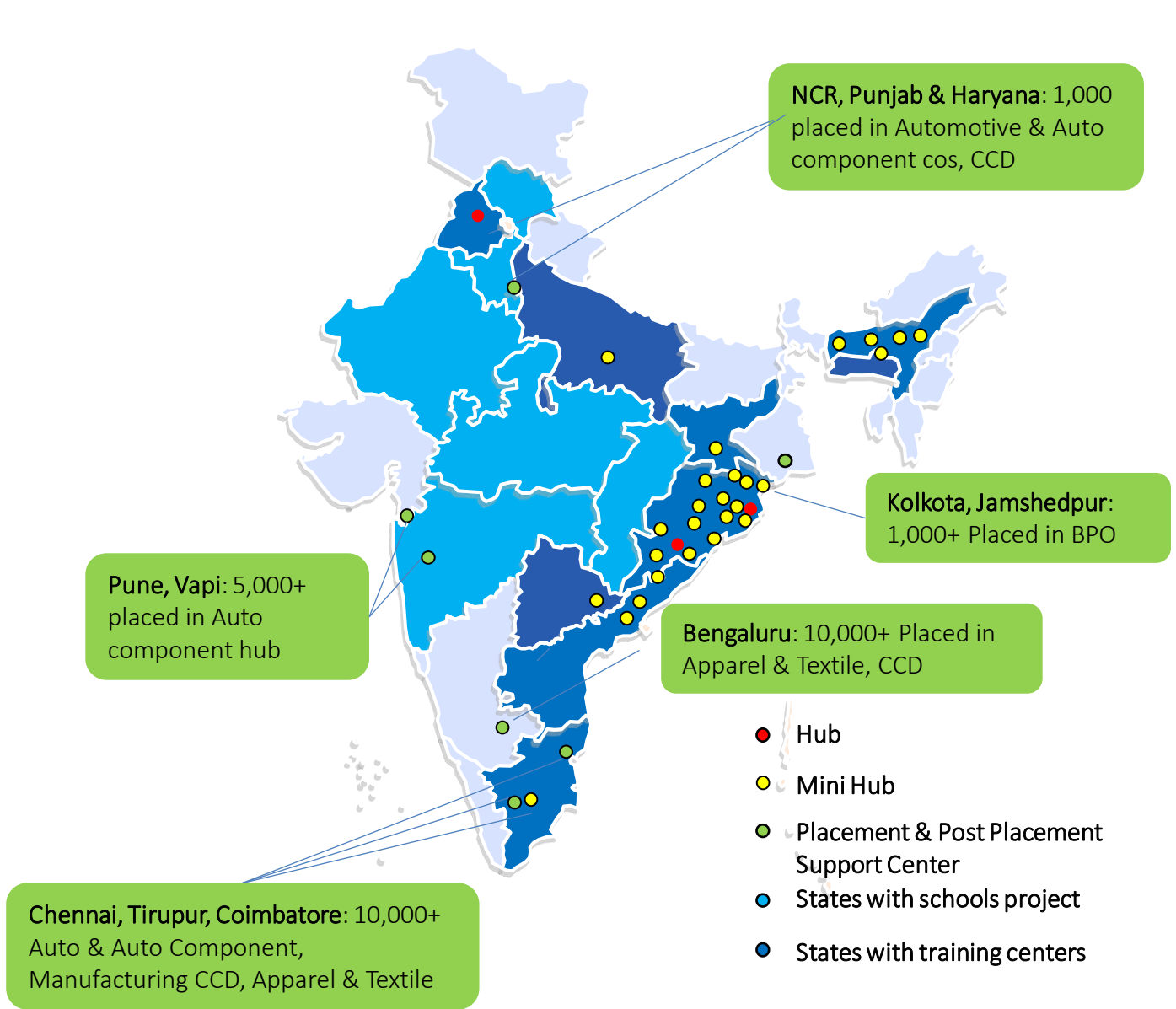

Skilling ecosystem in India

Paid Courses

Government Schemes

Industry & CSR

ITI,
Diploma,
Degree+

DDU GKY
Placement linked skill
training for rural poor

NULM
Skills for Urban
Poor

PMKVY
Skills for all

CCD, Ashok
Leyland, Mindtree,
Gap



Inclusiveness & Integration in course design

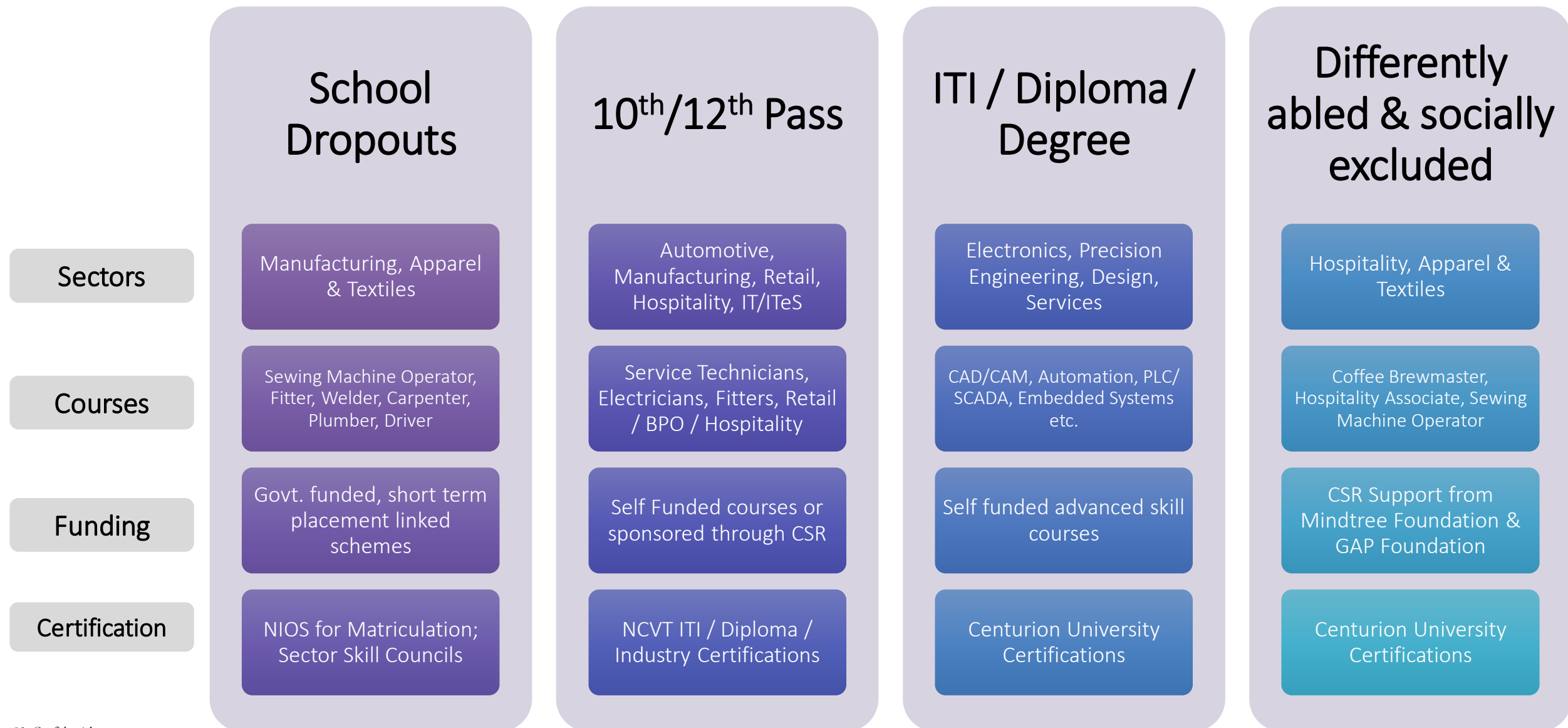

Horizontal & vertically integrated inclusive, aspirational learning model in action

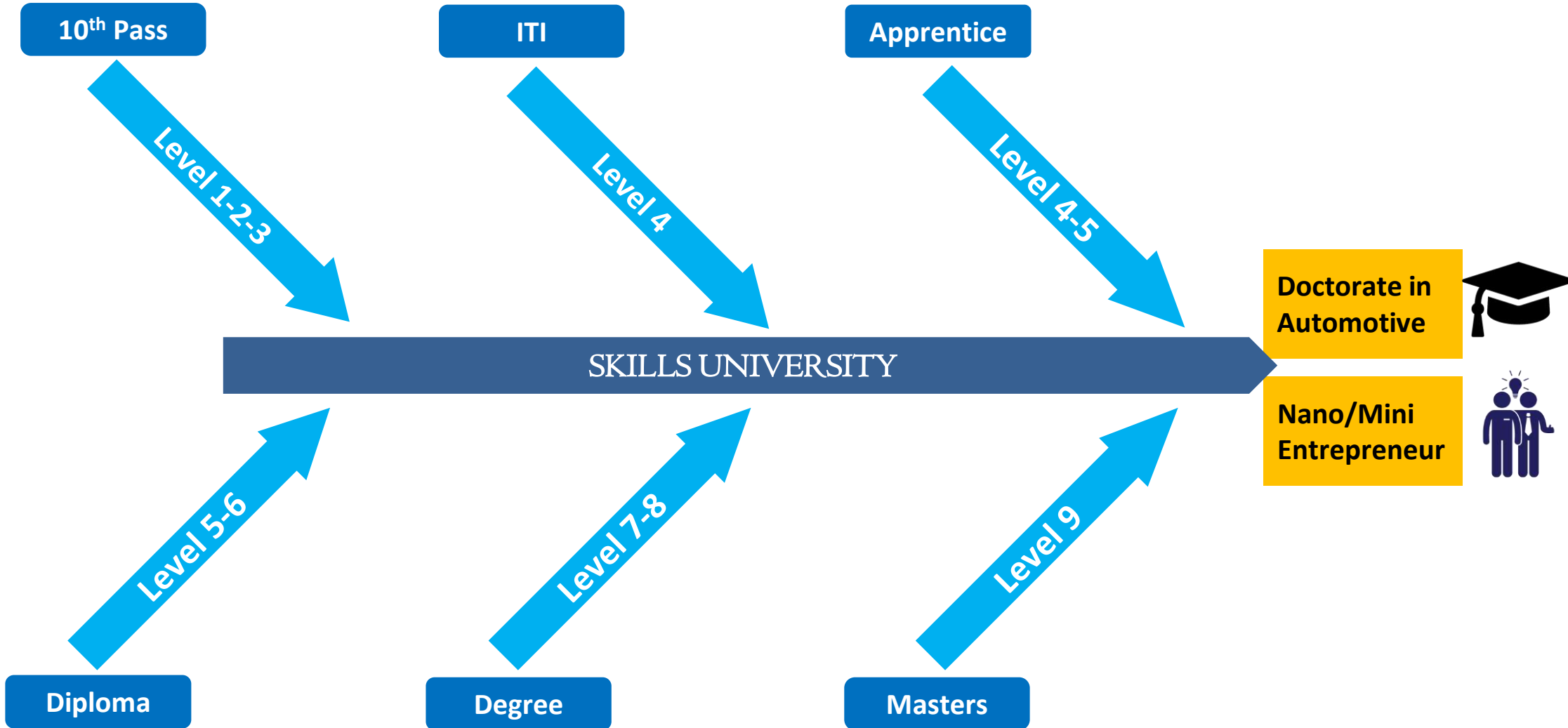

Revamping the traditional HE curriculum at CUTM

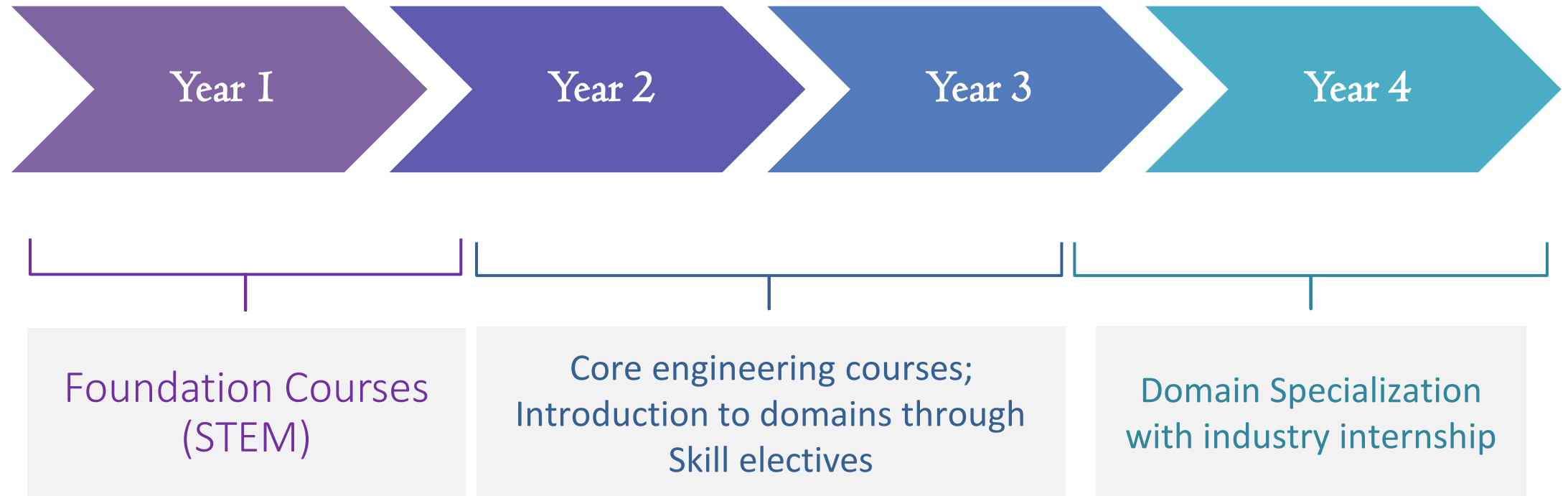

CUTM recognition as Skills University & Center of Excellence for Ministry of Skill Development & Entrepreneurship

1.1

16 criteria met for recognition as Skill University in Odisha

The Odisha Gazette

EXTRAORDINARY
PUBLISHED BY AUTHORITY

No. 1265, CUTTACK, SATURDAY, AUGUST 5, 2017/ SRAVAN 14, 1939

SKILL DEVELOPMENT & TECHNICAL EDUCATION DEPARTMENT

NOTIFICATION

The 26th July, 2017

Sub: guidelines for recognition of a University as Skill University in the State.

No. 3653–SD-MIS-48/2017/SDTE.— The proposal for recognition of any existing Government / Private University of the State as Skill University by according the status of the Skill University to it was under active consideration of the Government. Hence, in order to facilitate the same, Government have been pleased to prescribe the following guidelines / eligibility criteria for recognition of the existing Government / Private Universities of the State as the Skill University:—

1. The concerned University should have been in existence for minimum five years with approval of UGC and without any break.
2. It should have minimum five years of experience in imparting short term and long term skill training.

3. The University should have obtained National Assessment and Accreditation Council (NAAC) certification with at least 'A' Grade.
4. The University should have the experience of skilling 25,000 youth in last five years under Government programmes or Government agency sponsored schemes/ certification with a proven capacity to train at least 5,000 youth per annum.
5. It should have earned a national reputation on skill development.
6. It should have the experience of working with State Govt. Departments and Govt. of India Ministries / agencies in the field of skill development.
7. It should have established partnership with various agencies such as NCVT/ SSC of the Ministry of Skill Development in the field of skill training and assessment.
8. It should have tie up arrangements with leading Industries in the field of skill training.
9. It should have well equipped laboratories and workshops for imparting state of the art skill training to the trainees.
10. It should be imparting multi disciplinary course curricula in the field of technology and skill.
11. It should have well trained faculties with industry exposure.
12. Adequate accommodation/hostel space for the trainees should be available with the University.
13. It should have proven track record of social and community engagement.
14. Obtaining 12(B) status from UGC would be an added advantage.
15. Ongoing partnership with NSDC shall also be an added advantage since NSDC monitors the training quality and numbers.
16. Providing skill training to differently able and other such special categories of youth as part of inclusiveness is desirable.

A rigorous evaluation process was followed for the Skill University Recognition

Five broad criteria established by MSDE for CoE recognition

1

Track Record of Skill Training

HPCL : Skilling of Hearing & Speech impaired youth.

SBI Foundation : Medical skill development training

HSBC: Skill Development of youth in ITeS and BFSI

OPTCL : Skill Development of youth in Power sector

And many more...

2

Infrastructure

Center for Apparel Training

Center for Automobile

Center for Testing Labs

Center for Wood Engineering

And many more...

3

Competent Human Resources

Dr. A M Mohanty
(ProVC, SOVET, CUTM)

Jagannath Padhi
(Director, SOVET, CUTM)

Tapan K Rath
(Dean, SOVET, CUTM)

Training and Admin staff

And many more...

4

International Associations

TAFE Western, for Vocational Studies

Various Australian Universities

GAP Foundation, US Consulate for English

International Labor Org. for Life Skill & Career Training

And many more...

5

TOT and Partnerships

PACE & WADHWANI FOUNDATION ToTs

SoVET-CUTM TOT for all PIAs of ORMAS, PR&DW Dept, Govt of Odisha

SoVET, CUTM TOT for trainers from all PIAs of Odisha Skill

SoVET, CUTM TOT Officers of Govt. ITIs from all over Odisha DTET, SD & TE Dept.

And many more...

2

Learning Philosophy & Pedagogy

Traditional Learning | Applied Learning | Action Learning



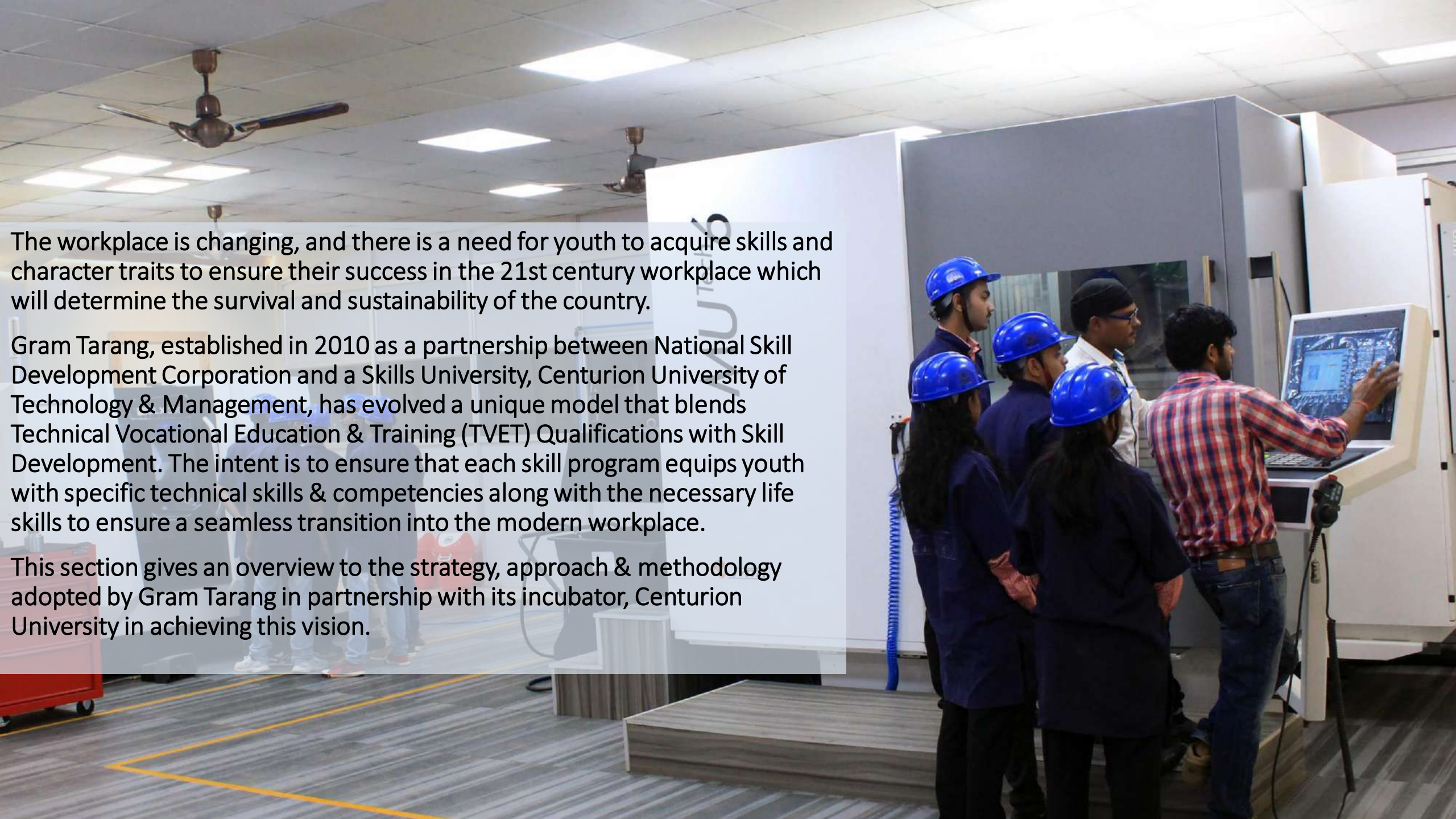

The workplace is changing, and there is a need for youth to acquire skills and character traits to ensure their success in the 21st century workplace which will determine the survival and sustainability of the country.

Gram Tarang, established in 2010 as a partnership between National Skill Development Corporation and a Skills University, Centurion University of Technology & Management, has evolved a unique model that blends Technical Vocational Education & Training (TVET) Qualifications with Skill Development. The intent is to ensure that each skill program equips youth with specific technical skills & competencies along with the necessary life skills to ensure a seamless transition into the modern workplace.

This section gives an overview to the strategy, approach & methodology adopted by Gram Tarang in partnership with its incubator, Centurion University in achieving this vision.

Our approach to learning

GTET's strategic framework & approach to skill development is based on the 4 strategies

1. **Learning Philosophy:** Hands on, Experience based learning
2. **Dimensions of Learning :** Six Dimensions of Skills
3. **Stages of Learning:** Three stages of Learning Teaching, Training & Production
4. **Delivery strategy & Process Orientation:** Ten Step Delivery Model.

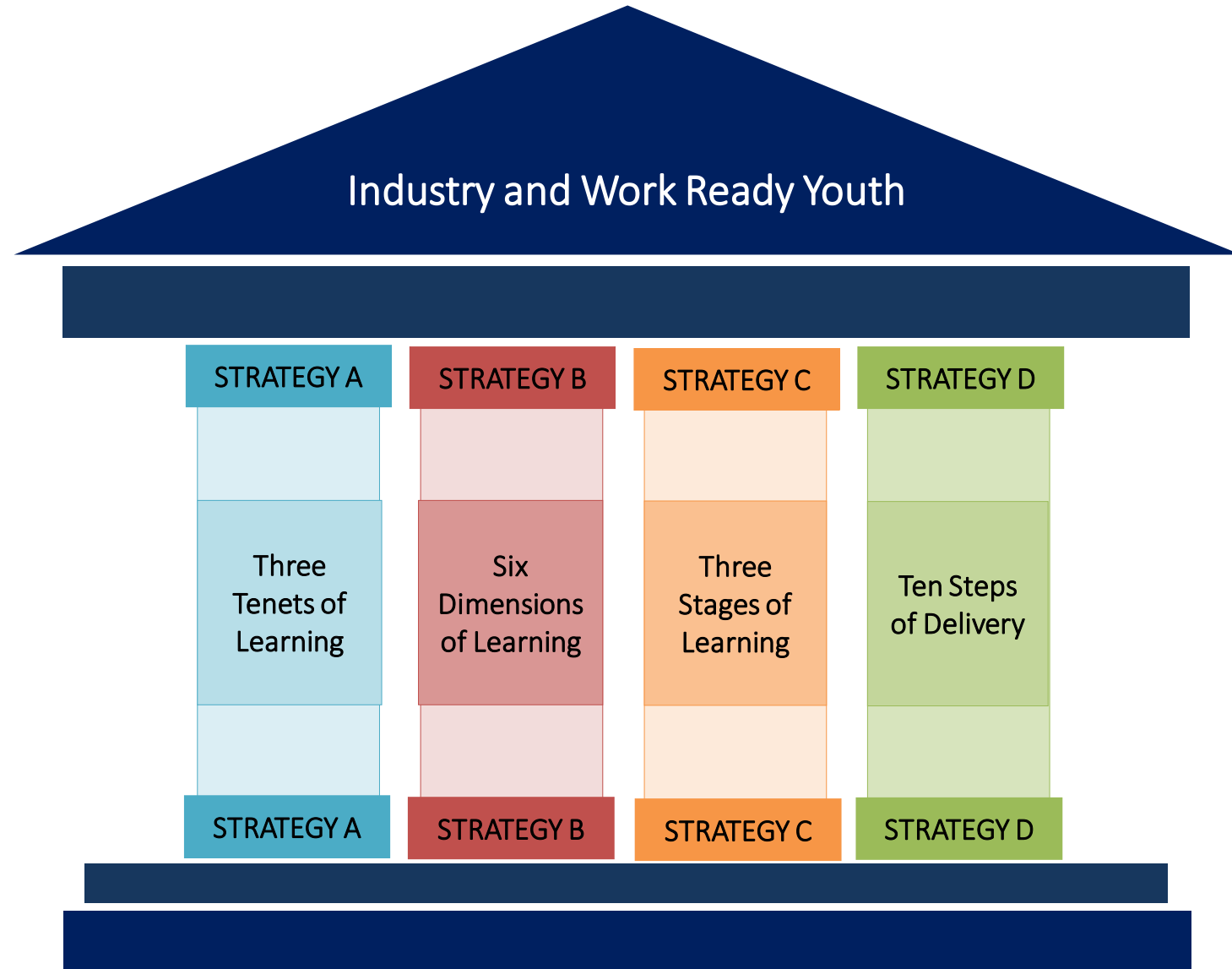

STRATEGY A: Hands on Learning

- The curriculum is one that allows for:
 - alternate ways and means of teaching & learning;
 - multiple points for entry & exit, and
 - one that is not theoretical & esoteric.
- The learning needs to be hands-on, experience-based and practice-oriented.
- The system of education should embrace diversity & take education to those who were most deprived & most in need of a livelihood
- **Teaching >> Training >> Production** becomes the model for delivery of this curriculum



Experiential Based Learning

- Focus on building technical competencies and hard skills through machine-based training



Practice Oriented Pedagogy

- 20% Theory
- 20% Life Skills, IT Literacy & Personality Development
- 60% Practical – in the workshop



Hands on knowledge & skills

- Each skill program finishes with a live project in terms of production – welding, fabrication, machining, garment, serving coffee, working with patients, etc.

STRATEGY B: The Six Dimensions of Skills

- Skill is not only limited to that what is learnt hands on, and a key focus has to be made on the softer aspects of the development.
- Therefore it has to be multi dimensional (or six dimensional to be precise).
- In addition to the Technical Domain the student will need to learn:
 1. Numeracy
 2. Literacy
 3. Professional Skills
 4. Life Skills
 5. Entrepreneurial Skills

- 6 Entrepreneurial Skills:** Encouraging students to gain hands on experience & through live production & incubating them to become nano/mini/micro entrepreneurs.
- 5 Life Skills :** Abilities for adaptive and positive behavior that enable individuals to deal effectively with the demands and challenges of work life & employment like IT literacy, financial literacy & legal literacy, financial planning for self and family, health, health, hygiene & sanitation.
- 4 Professional Skills :** The key behaviors, actions and thinking processes necessary to build a successful career like values, ethics, integrity, teamwork, communication, planning, time management & leadership etc.

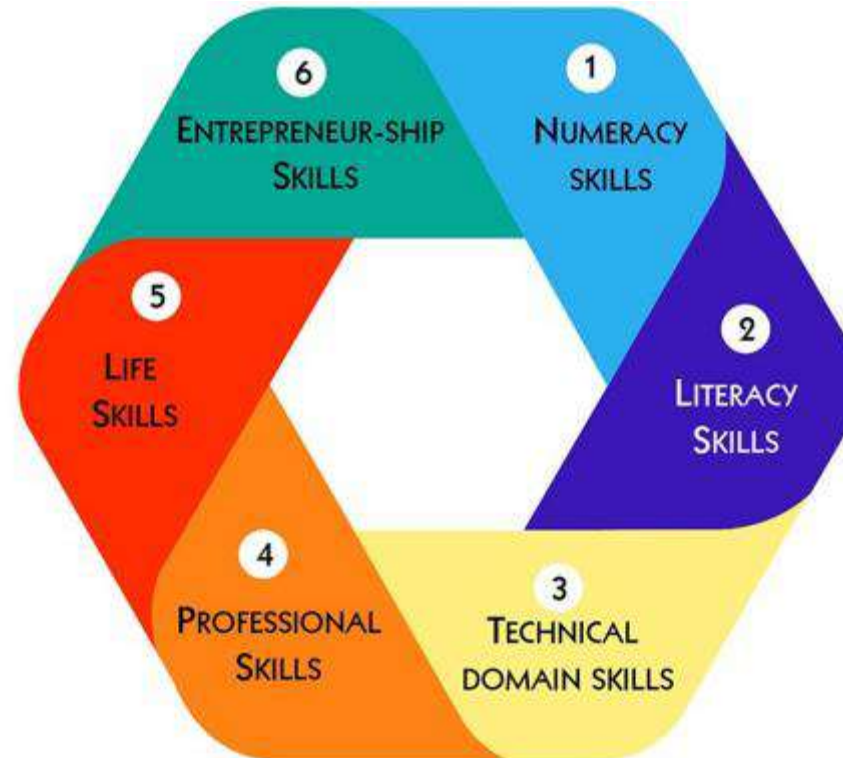

- 1 Numeracy skills :** Ability to use mathematical understanding and skills to solve problems and meet the demands of the job e.g. workshop measurement, calculation & basic arithmetic.
- 2 Literacy skills :** Capacity to read, understand and appreciate various forms of communication including spoken language, printed text and digital media required for the industry & trade.
- 3 Technical domain skills :** Trade specific technical or core knowledge & practical skills required for expertise in a trade.

STRATEGY C: The Three Phases of learning

- The learning system of GTET provides a holistic view of learning to the student that ensures that she/ he is skilled for the job market but also passes the academic rigour expected of a student of the same qualification level.
- GTET has no intention of diluting the learning of the student from the current system, but instead reinforce that learning with more practical/ hands on learning. This is done through the three phases of learning:

1. **Traditional Learning** in classroom
2. **Applied Learning** in lab
3. **Action Learning** through live production



PHASE I: TRADITIONAL LEARNING

- 1 **TEACH ME**
Traditional learning methods of building a foundation for the course which will involve development of trade specific knowledge, literacy, numeracy & technical skills.
- 2 **SHOW ME**
Learning through practical demonstration in workshop or work environment where trainees will observe tasks and procedures being completed, making notes along the way and understand SOPs.

PHASE II: APPLIED LEARNING

- 3 **LET ME PRACTICE**
As the saying goes... practice makes perfect! Industry specification machines & production environment for hands on learning and working on the practical elements of doing the job.

PHASE III: ACTION LEARNING

- 4 **ASSESS ME & TELL ME HOW I AM DOING**
Assessment is a continuous process with daily assessment of practical learning on dimensions of accuracy, process & time taken.
- 5 **LET ME SHOW YOU WHAT I CAN DO**
Trainees turn to demonstrate learning and independently practice the learning from doing jobs & practical while producing a good or service of social-economic value in a live production environment.
- 6 **RECOGNIZE ME**
Skill championship to build competitive spirit and recognize the high performers of each batch. Independent 3rd party assessment through Sector Skill Councils or NCVT for final certification of a new "professional".

STRATEGY D: Process Orientation & Ten Steps of Delivery

- The delivery of the training is key for the success of any program.
- While the training itself is important where the development and selection of the trainer is crucial there are other aspects around the training that is important for the success:
- Counselling of the candidates before, during and after the training. This is important to ensure that the students are motivated and their aspirations are aligned to the real world circumstances;
- Assessment with a proper feedback and remedial system;
- Post placement support, particularly to ensure the student has access to the University for further learning and growth.



Models of working with Industry

- Over the past 10 years GTET has been working across various companies to introduce industry practices and the latest technologies to its students.
- It has been the experience that there is no “one size fits all” model for Industry partnerships, the approach with various industries depend on a number of factors:
 - The business cycle they are in;
 - The partnership needs to be positioned within the long-term strategic vision of the company – especially from a commercial perspective (it cannot be a grant or CSR only);
 - The output of the training has to have a concrete impact on the company’s top-line and/or bottom-line.
- Therefore, it is important to be flexible on the form of partnerships with various industries with the aim of having the maximum possible.

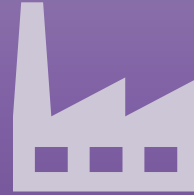

Work Integrated Training at the Industry Location:

- GTET has partnerships with Industry Partners where its students go to the industry for their OJT – this is typically the last phase of the student’s learning
- The OJT is an immersive experience of working in that industry, there is no project work or unlike an internship.



Setup Enterprises

- The university nurtures students and supports entrepreneurs to develop business ideas into social enterprise
- This includes a transformer manufacturing unit, an apparel unit, designing, prototyping and commercializing a 3D Printer, creating, cultivating and marketing a hybrid rice variety, a system integrator for Dassault Systemes, etc



Partnership with Industry to establish Applied & Action Learning Labs:

- GTET has 26 industry partners who have setup “Action Learning Labs” in the University campuses;
- Action Learning Labs provide students with a real-life simulation as in working in the actual industry and are equipped with the latest tools and equipment.

Model I: Partnership with Industry to establish Action Learning Labs

- GTET has formed partnerships with some of the largest companies in India to setup Action Learning Labs. These labs provide students access to the latest industry practices and technology.
- In a typical partnership the companies provide GTET with:
 - Tools and equipment;
 - Training of Trainers;
 - Curriculum support;
 - Access to placements/ internships;
 - Branding and marketing support.
- The support could be all the above or a combination of the items.



Godrej & Boyce divisions:
Appliances | Material
handling | Interio | Process
Equipment | Vending



GE Healthcare



BOSCH
Invented for life





Renewable Energy Labs in partnership with Schneider Electric

Joint skill development courses with Ashok Leyland



ASHOK LEYLAND

1. **Commercial Vehicle Service Technician (ITI):** An intensive 4-month residential course focusing on hands on skill Development of ITI recruits for deployment at dealer points
2. **Commercial Vehicle Service Technician (10th pass candidates):** One year course piloted in Ludhiana for training & placement of 10th pass youth as Service Technicians at dealer points
3. **Auto Electrician:** 2 month residential course for developing ITI Electricians as Auto Electricians
4. **Skill Upgradation of Dealer staff:** In 2014, activities of the Zonal Training Center Kolkata were transferred to the Bhubaneswar center and it was used to provide training to dealer technicians across East & North East
5. **Skill elective courses of University** undergraduate, diploma & ITI students



Locations: CUTM Bhubaneswar | MSDC Ludhiana



Industry integration with
Yamaha



Textiles: Spinning & Power Looms



Working with the differently abled



Mindtree

Welcome to possible



Flagship Program: Go to market in 100 days with Dassault

EXPERIENCE INDUSTRY IN 100 DAYS.

*Design any product from pin to plane
using Dassault 3D experience platform.
Stand a chance to validate, prototype, manufacture
and launch your concept in the market.*

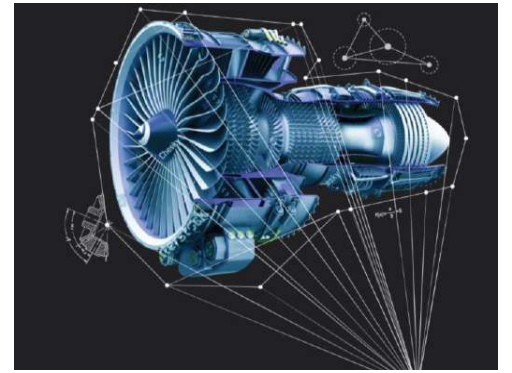
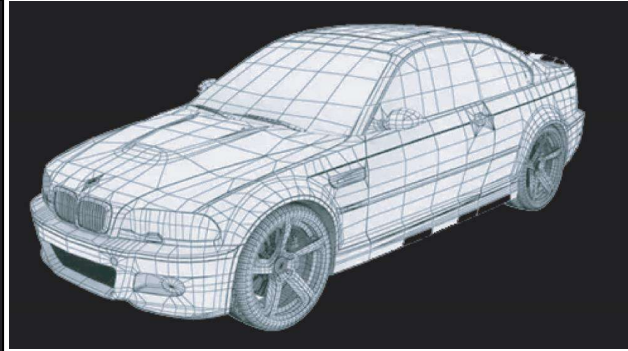

3D Experience Platform

Digital Product Development in partnership with Dassault

Design & Development of Electric Vehicle



Design & Development of eRickshaw

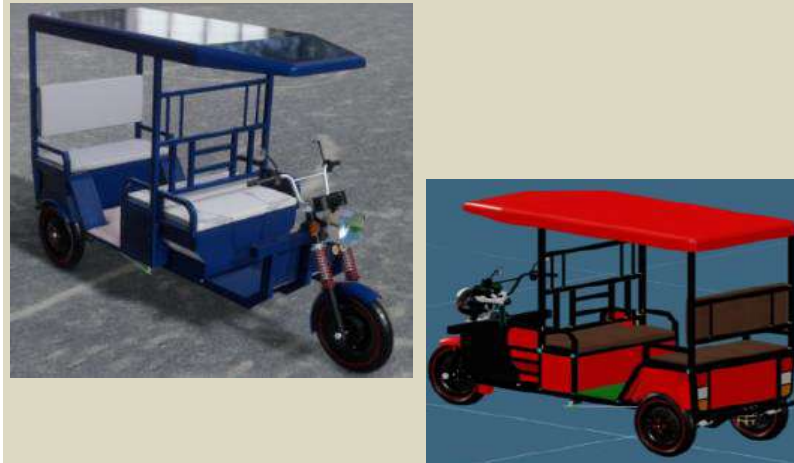

Drone for Surveillance & Agriculture

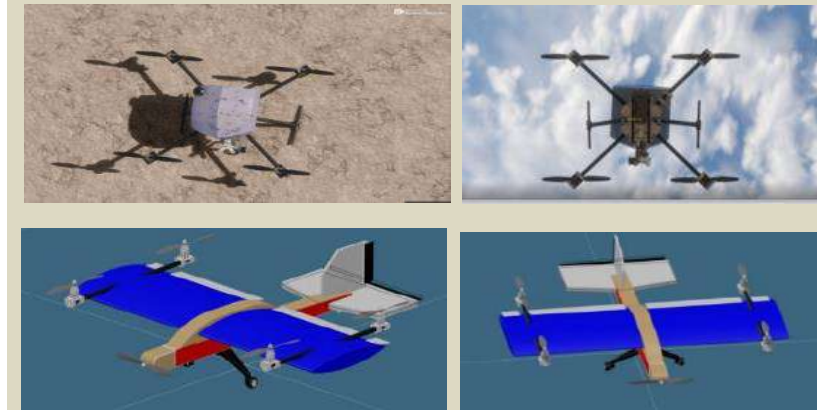

Pick & Place Robotic

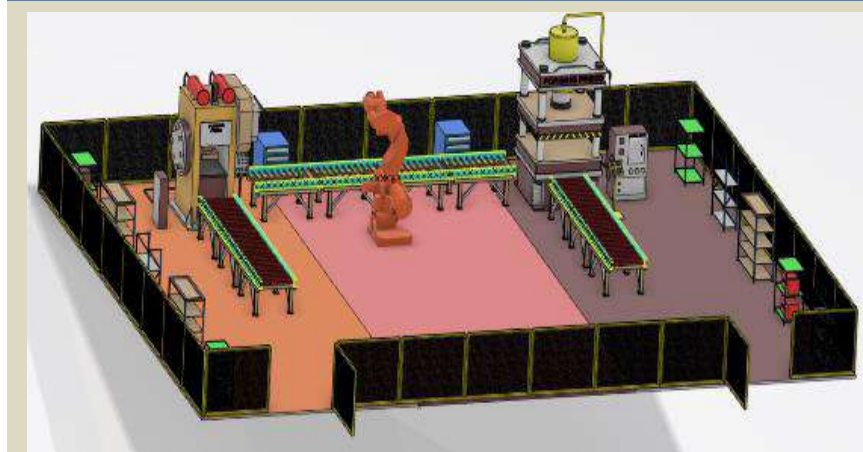

Humanoid

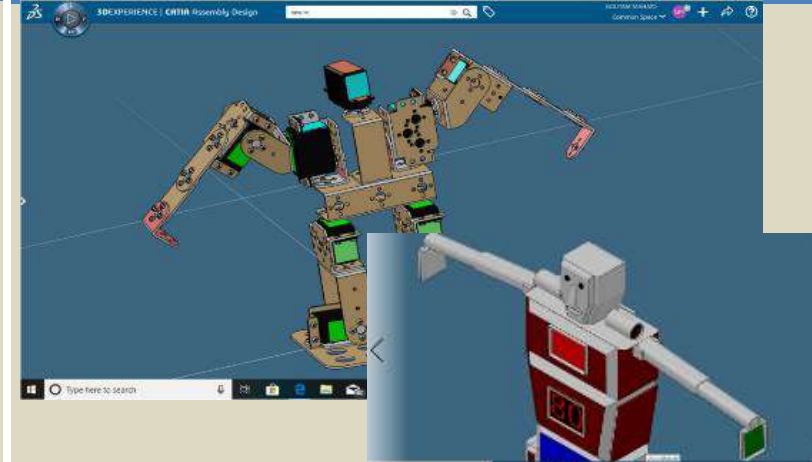

3D Printer Machine

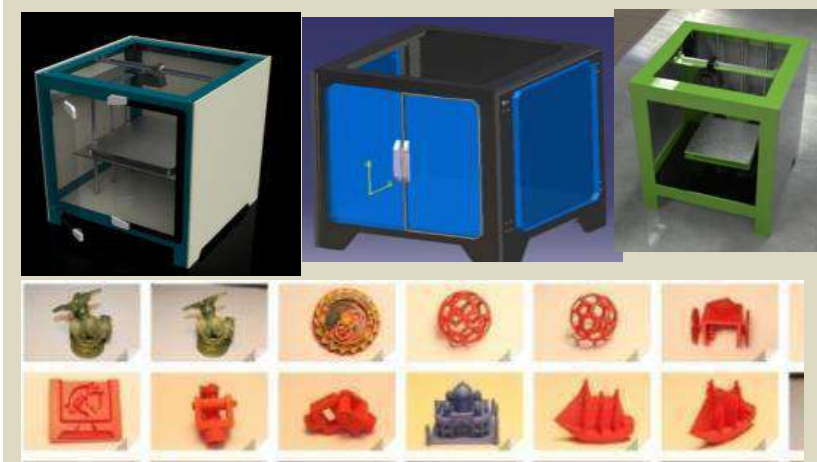

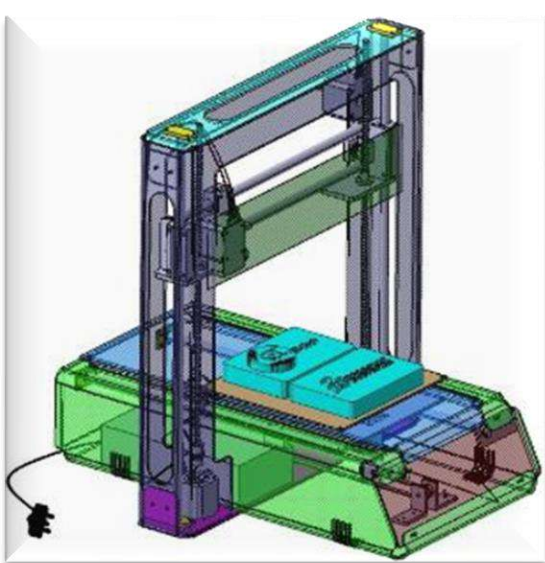

Scope

- Digital Product Design
- Market study of Problem Statement
- Tear Down and Bench Marking
- Concept Design
- Basic Hand calculation
- Product Costing & Target Cost
- Product Design – System & Subsystem
- Product Integration
- System Engineering - Mech – EE – ECE
- Design Review – Virtual Reality
- Simultaneous Engineering
- Design Optimisation
- Prototyping

Technology/Software

- 3D EXPERIENCE Platform of DS
- CATIA (Sketcher, Part design, Drafting, Assembly, Remastering, Welding design)
- CATIA Sheet metal Design
- CATIA Live Rendering
- CATIA ICEM Surface Design
- CATIA BIW Design
- DYMOLA

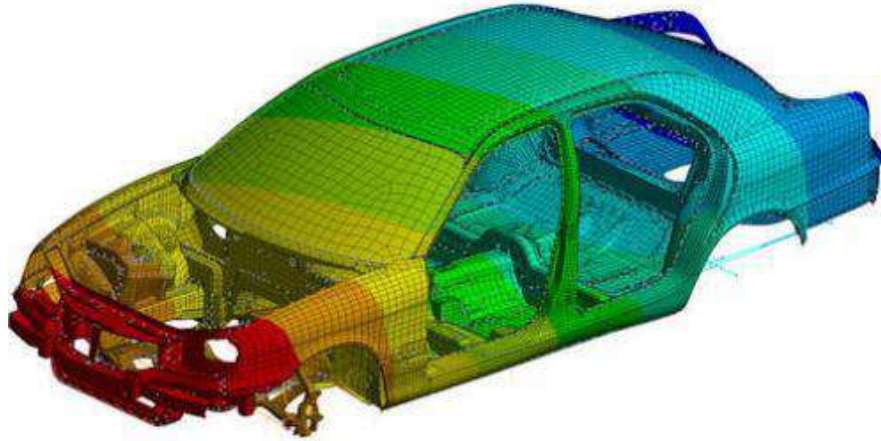

Meshing of Monocoque chassis

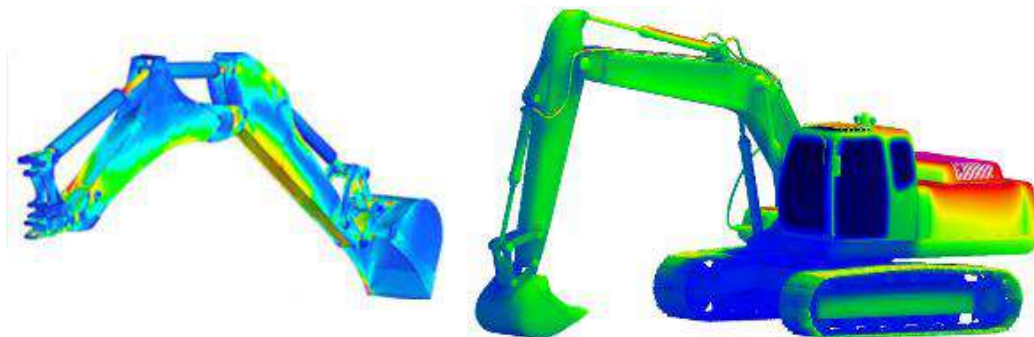

Static load analysis of Heavy vehicle

Learning

- Overview of Finite Element Analysis
- Stage of Analysis
 - ✓ Pre-Processing - 2D & 3D Meshing, Material Assignment, Load cases
 - ✓ Solving – Solving on Abaqus, Simulia
 - ✓ Post-Processing – Result evaluation, Stress & Strain graph
- Types of Analysis
 - ✓ Static load Analysis
 - ✓ Service Level Analysis
 - ✓ Dynamic Load Analysis- Apply constraint during simulation, Apply material properties, Observe behavior of the suspension of E-Bike.
- Overview on Computational Fluid Dynamics (CFD) Analysis- Numerical analysis, Data structure to analyze fluid flow behavior, Study of Mesh of CFD.

Technology/Software

- 3DEXPERIENCE Platform of Dassault Systemes
- SIMULIA – Structural model, Structural Scenario, Mechanical scenario, structural validation, Durability validation, Fluid model, physics results.
- ABAQUS CAE

Model 2: Production & Action Learning

GTET's pedagogical philosophy required that it had incubated business units within the ambit of the University where they could provide its students and faculties with real exposure to businesses and livelihood opportunities. This is in addition to the regular academic research, papers and patents that are produced by the University.

GTET is managing & running CUTM's CIE or Center for Innovators & Entrepreneurs and has been registered with Startup Odisha as an Startup Incubator

Where possible GTET provides its students exposure to the real life projects through these companies, the table on the right provides a description of some of these companies.

The exposure given to the students is across the spectrum of the industry and not only its core activity, such as:

- Real life business management challenges – marketing, logistics, finance, accounts, data analysis, etc;
- Design challenges;
- Personality, teamwork and leadership development challenges.

GTET is an important Social Enterprise as it was established as an extension/ outreach of the University.

S.No.	Organisation	Activity
1	GT Employability Training Services	Training and workforce solution company working with Industry to supply, upgrade and maintain its workforce
2	GT Electric	Govt. approved and accredited transformer production unit which supplies to State government distribution companies
3	Apparel Production	Full fledged apparel manufacturing unit which has even delivered 3 lakh masks during COVID
4	Urban Micro Business Center	Urban outreach initiative to create entrepreneurs among urban poor, particularly women
5	GT Technology	Bringing Industry 4.0 solutions to the farmers and underprivileged
6	GT EV	Electric Vehicle Manufacturing
8	GT Manufacturing	Manufacturing activities – apparel, wood engineering, fabrication and high precision machining

[GT: Gram Tarang, "Gram" meaning village and "Tarang" meaning wave]

Incubated Units

for **Startup
Odisha** 



Apparel Manufacturing Center of Excellence



**TEAM
GTET's**

Apparel & Textile Center of Excellence swung into action in response to the COVID 19 pandemic by producing Personal Protective Garments



Centurion
UNIVERSITY



www.gramtarang.in

Apparel Production center of excellence



Process Flow

1. CUTTING



2. STITCHING



3. ASSEMBLY



4. INSPECTION



5. SANITIZING & HEAT TREATMENT



6. PACKAGING & DISPATCH





PRECISION MANUFACTURING AND ADVANCED MACHINING

GTET is a registered Component supplier to HAL, RSB, SMS





Precision Machining Center

Mini Tool Room & Training Center at Bhubaneswar & Paralakhemundi



HAL & ISRO Production Jobs

Transformer Unit



MANUFACTURER AND REPAIRER OF ALL KIND OF TRANSFORMERS

Gram Tarang, the social enterprise of Centurion University, Skill University of Odisha provides hands on vocational training to youth in live production environment. With a special focus on vocational training in energy sector, Gram Tarang has established a state of the art Transformer Manufacturing and Repair Workshop which undertakes orders from many discoms and private clients. Our processes and products have been certified as meeting and exceeding national and international quality standards including BIS Level-II approval for 16 / 25 / 63 / 100 / 250 and 500 KVA Distribution Transformers and ISO 9001:2015.

MANUFACTURING FACILITIES

We have the most modern and high-tech machines like power sheering machines, Hydraulic press brake, automatic HT and LT coil winding machines, Single/double head DPC machines, Oil Conditioning machine, Thermostat controlled heating chamber, spray booth and 27KL Lube storage tank.

TESTING FACILITIES

We also have high precision testing equipment like 3-Phase M-G Set with DVDF Test Set, Transformer Oil Insulation Test Set, Turns Ratio Tester, Digital Insulation Resistance Tester, Motorised Insulation Tester, Power Analyser, Winding Resistance Meter, High precision micro OHM meter, Turns ratio tester and CT & PT for best monitoring of quality output of our transformers.

TRANSFORMER MANUFACTURING PROCESS

1. CORE & COIL ASSEMBLY

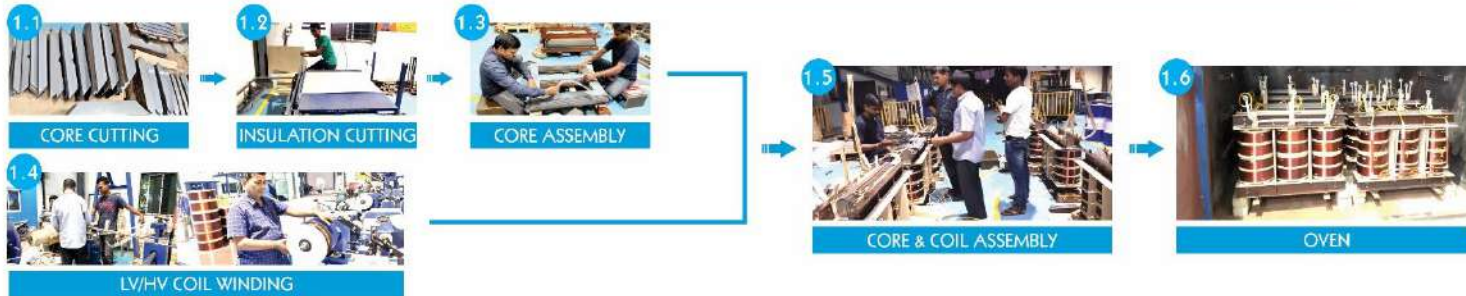

2. TANK ASSEMBLY



3. FINAL ASSEMBLY & TESTING

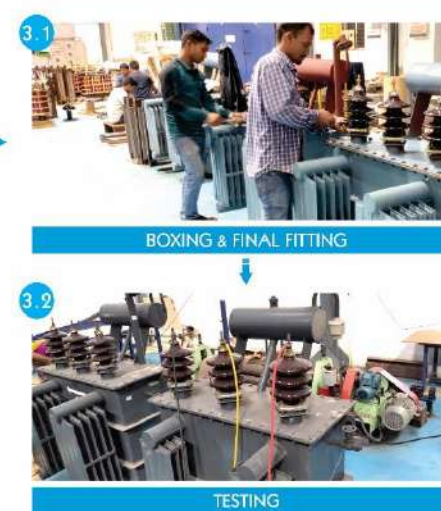

**CENTURION
UNIVERSITY**
*Shaping Lives...
Empowering Communities.*



www.gramtarang.in

Transformer Manufacturing Process







SKYY RIDER
ELECTRIC

The Future of Transport

WWW.SKYYRIDERELECTRIC.COM

Electric Vehicle



Save nature save future

Made in ODISHA



e-Rickshaw OMFED order of 40 refrigerated carts delivered

Advanced Wood Engineering

R

Shot on Redline 2
By AJAY 🇮🇳





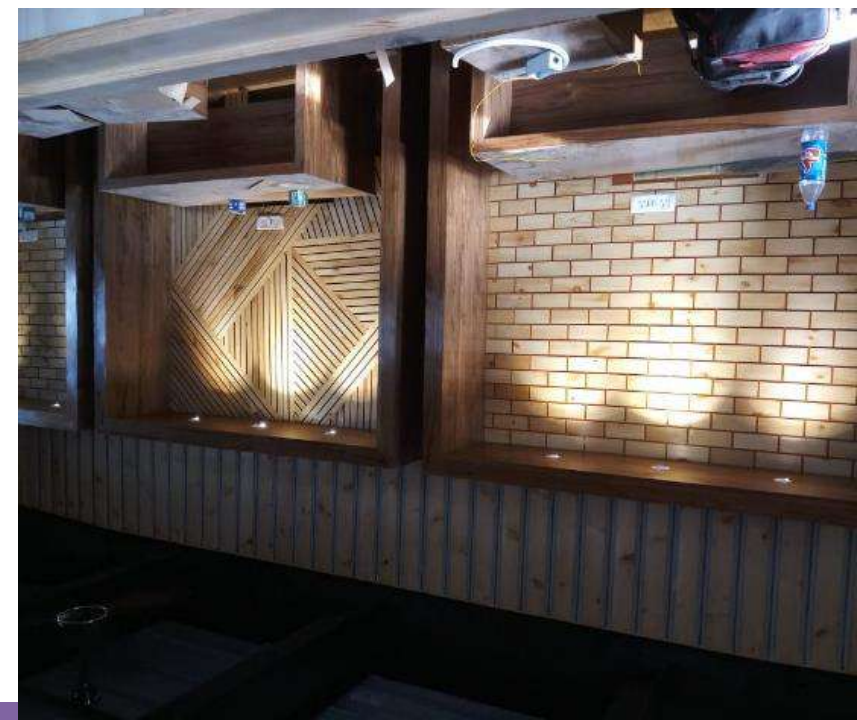

Community Diagnostic Center

FORM-C
(See Rule-3(6) and Rule-4)
GOVERNMENT OF ODISHA,
HEALTH AND FAMILY WELFARE DEPARTMENT
CERTIFICATE OF REGISTRATION
Under Odisha Clinical Establishments (Control and Regulation) Act, 1990

This is to certify that Sri Sunil Kumar Jha, an applicant for registration of M/s- Community Diagnostic Centre, in the capacity of Director, At- Centurion University of Technology and Management, Ramachandrapur, PO- Jatni, Dist- Khordha- 752050 has fulfilled the criteria to run a Clinical Establishment with following services only.

Category as per Schedule-A (with beds)	Diagnostic Services provided	Others Services
Nil	Schedule-IV, Table- A/Category- E (Biochemical/Pathological investigations without high end equipment.)	Nil

The establishment is registered under the provisions of the Act with following particulars and terms and conditions.

REGISTRATION NUMBER : 38/2019/Khordha Date of Issue: 02.08.2019

PERIOD OF VALIDITY : From 02.08.2019 to 01.08.2024

INCHARGE (If a doctor then the, Dr. Debasis Sahoo, MD (Microbiology), Regn. No. 16311/2007(with qualification).

[Signature]
Signifying Supervising Authority
Collector & District Magistrate
Khordha

Terms and Conditions:

1. That the CE shall abide by the provisions of the Odisha Clinical Establishments (Control and Regulation) Act, 1990, rules made there under.
2. That for renewal, application shall be made to the authority not less than six months before its expiry.
3. Any change in the constitution or management of the clinical establishment shall be intimated not later than fifteen days to the supervising authority along with the original certificate for issue of new one.
4. Any change of staff of the Clinical establishment must be reported to the Supervising Authority within one month of such change.
5. All certificates of the establishment including OSPCB, Fire Safety, Trade License, approved rate chart, name of staff on duty etc. must be displayed in a prominent place for viewing of public.

REGD. POST
OFFICE OF THE CHIEF DISTRICT MEDICAL AND PUBLIC HEALTH OFFICER: KORDHA
No. 9088/ Date 4/8/19

To

The Director,
M/s- Community Diagnostic Centre,
At- Centurion University of Technology and Management,
Ramachandrapur, PO- Jatni, Dist- Khordha.

Sub: Grant of registration of M/s- Community Diagnostic Centre, At- Centurion University of Technology and Management, Ramachandrapur, PO- Jatni, Dist- Khordha under OCE (C&R) Act and Rules framed there under.

Sir,

I am directed to enclose herewith the original copy of registration certificate bearing Regn. No. 38/2019/Khordha in favour of M/s- Community Diagnostic Centre, At- Centurion University of Technology and Management, Ramachandrapur, PO- Jatni, Dist- Khordha granted under OCE (C&R) Act and Rules framed there under for the period from 02.08.2019 to 01.08.2024 for your information and necessary action.

Receipt of the Registration Certificate may be acknowledged.

Yours faithfully,

[Signature]
Chief Dist. Medical & PHO, Khordha









Concrete Pavers Unit

3

Advanced Skills with Gram Tarang Technologies

Making students Industry 4.0 ready through product design & development

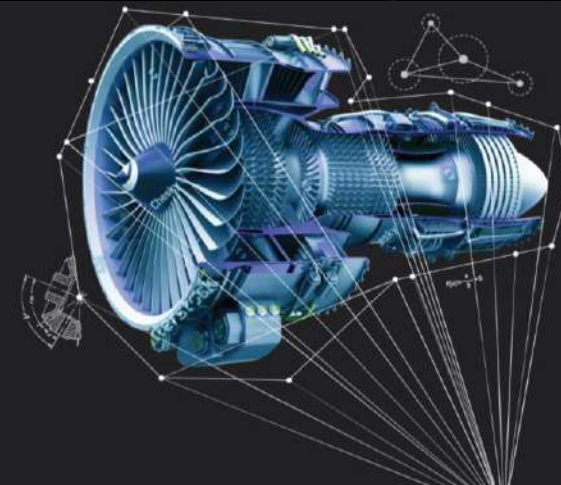
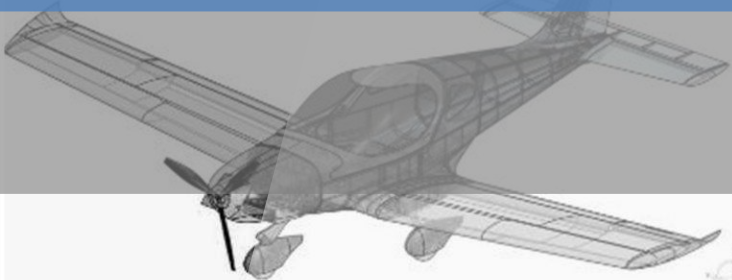

Flagship Program: Go to market in 100 days with Dassault

EXPERIENCE INDUSTRY IN 100 DAYS.

*Design any product from pin to plane
using Dassault 3D experience platform.
Stand a chance to validate, prototype, manufacture
and launch your concept in the market.*

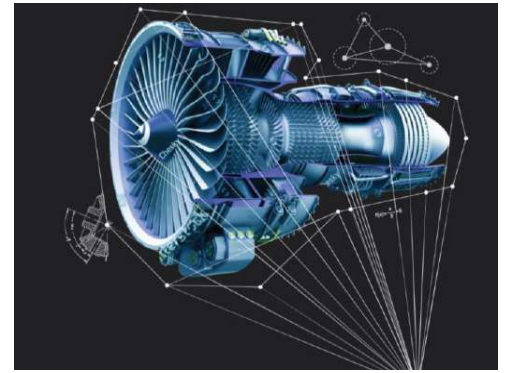
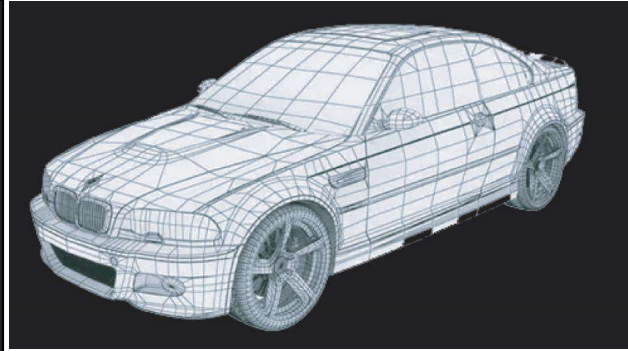

3D Experience Platform

Key Industry Partners for Advanced Technologies



Advance Mechanical
Services Bangalore



Dassault Systemes



AUS - Aarav Unmanned Systems



General Aeronautics



AMTZ- Vishakhapatnam



UNITY

Projects delivered in partnership with Dassault Systems

- **Center of Excellence** setup in ANU Vijayawada & Skill development program undertaken for 25,000 students across 60 Engineering Colleges in AP in automotive, aerospace and ship building domains
- **Skill development program** in GTTC in Karnataka
- **CPMS** – Centralised Project Management Systems in APSSDC
- **Smart City Project** in Jaipur
- **Virtual Construction** for L&T Mumbai



Product Development

1 Electric Vehicle – Small Commercial Vehicle

- Design of Electric Vehicle -Small Commercial Vehicle
- Validate the Product
- Use all multi-disciplinary brands of Dassault Systemes
- Design for Semi & Full autonomous
- Digital Design of an assembly line of 5 vehicle per day
- Productionisation of vehicle

2 3D-Printing

- Design a Domestic 3D Printer Machine at low affordable cost to reach every home
- Import 3D Metal Printing machine – WarpSpee3D and commercialise the service
- Commercialise existing 5-Axis Machining Centre
- Build infrastructure for post-processing

3 Agriculture, Health & Life Science

- Crop Yield Improvement using machine learning
- Develop product for Precision agriculture (Protected cultivation)
- Design & develop health care devices
- Biotech Research, design & Development of drugs, Bio-sensors & Genetics Engineering - Animal & Plant

4 Aircraft & Drone

- Design & development of Two Seater – Fixed wing aircraft
- Partnership with General Aeronautics – IISc Bangalore
- Augment Drone with hyperspectral /Multi-spectral camera to capture, analyse and Process for agri operation
- Design Drone for payload of 500Kg

5 Augmented & Virtual Reality

- VR enabled learning experiences using Hologram Technology for 30 trades of ITI
- VR kit for Digital Walk though of an Factory & more eLearning kit
- VR enabled learning kit for Time analysis of assembly shop
- Develop more industrial products on XR

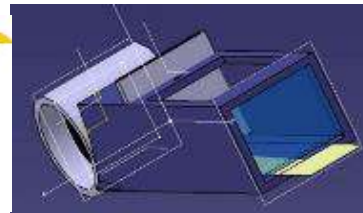

Digital Product Development in partnership with Dassault

Design & Development of Electric Vehicle



Design & Development of eRickshaw

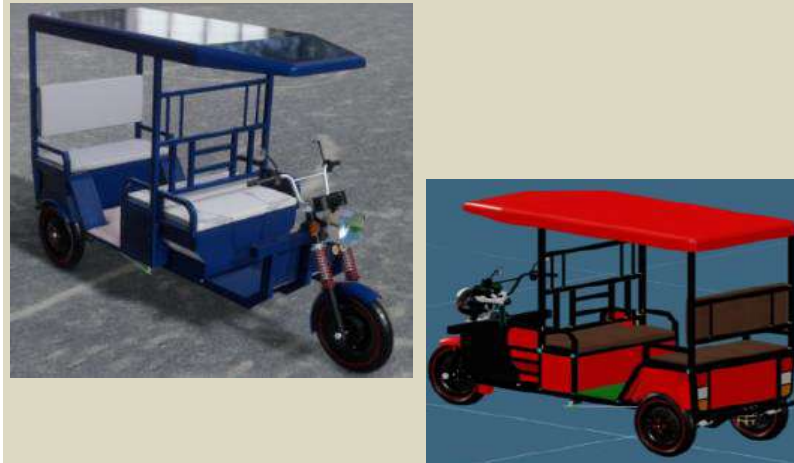

Drone for Surveillance & Agriculture

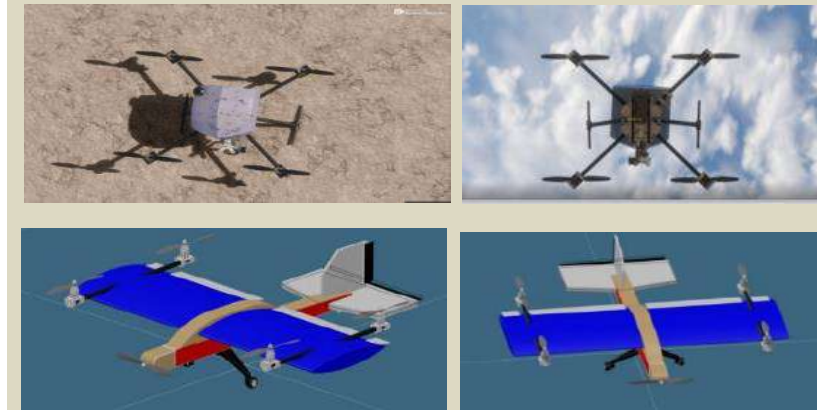

Pick & Place Robotic

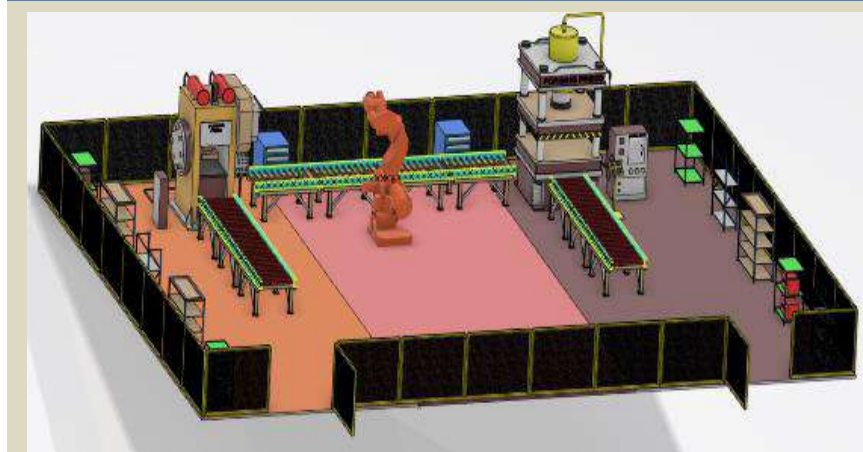

Humanoid

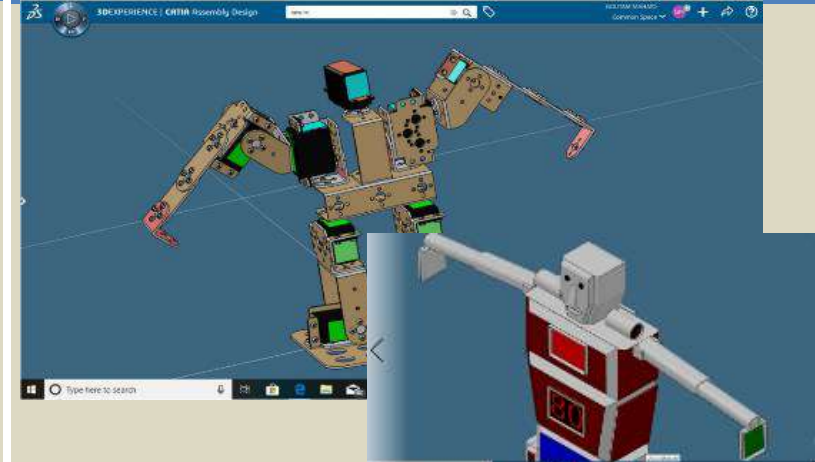

3D Printer Machine

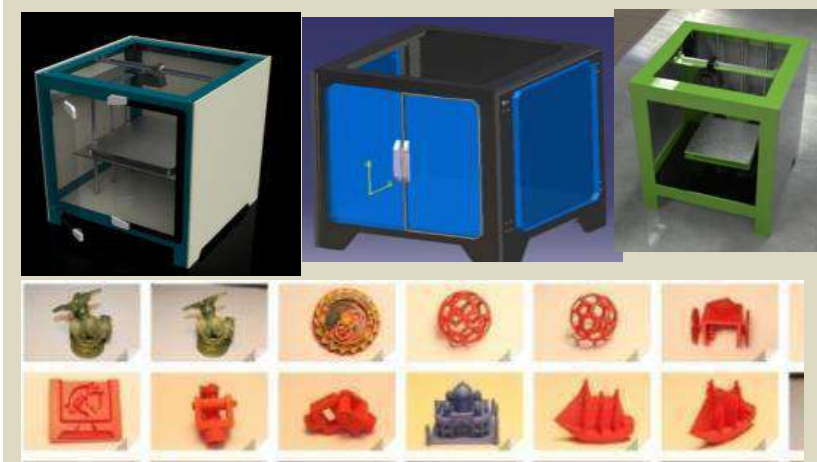

High End Solution Implementation

1

Geovia

- Geovia Product – Surpac, Whittle & MineSched
- Geovia Solution and solution Implementation
- Drone based end to end solution & centre of Excellence

2

Biovia

- Biovia Product – Material studio, Discovery studio, Image studio, Pipeline Pilot
- Biovia based solution implementation for Research

3

Solution Implementation

- Dassault Systemes solution implementation in Skill Development
- Centralized Project Management Systems
- High end engineering services using 3D experience Platform of Dassault Systemes.

4

Other Solutions

- 3D Experience Smart City Solution implementation
- AEC for BIM solution Implementation
- Enovia Customisation & solution

5

R&D Centres

- High end Research & Design Centers

SCV- Electric Vehicle



Tech Specification of Current Vehicle Small Commercial Vehicle 'gMINT'

Overall dimension	3790 *1500*1845 mm
Wheel base	2100 mm
Ground clearance	200mm
Speed	40-50 KMPH
Motor	BLDC Motor (72V, 7.5 KW) 2000-6000 rpm
Range	80-100 km/charge
Battery Capacity	SLA /SMF lead acid battery (6 nos, 12V, 200Ah)
Kerb weight	700 Kg
Gross vehicle weight	1500 Kg
Turning radius	4300 mm
Seating capacity	7+1

Area	Product Plan
Segment	Small Commercial Vehicle (<2.5 Ton)
Sector	Rural & Urban (Pick-up, VAN, Buses,Truck)
Type	Passenger and Loady body
Model	1.5 T, 2T, 1T, 2.5T
Variants	Variants on BMS,Features on above models

2T Payload Drone

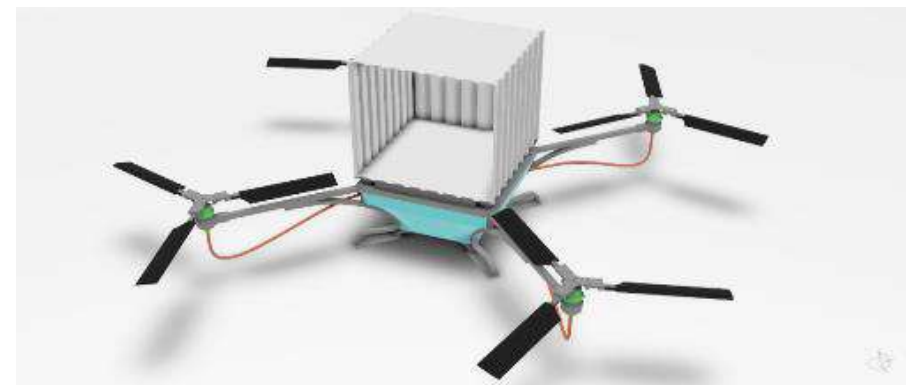
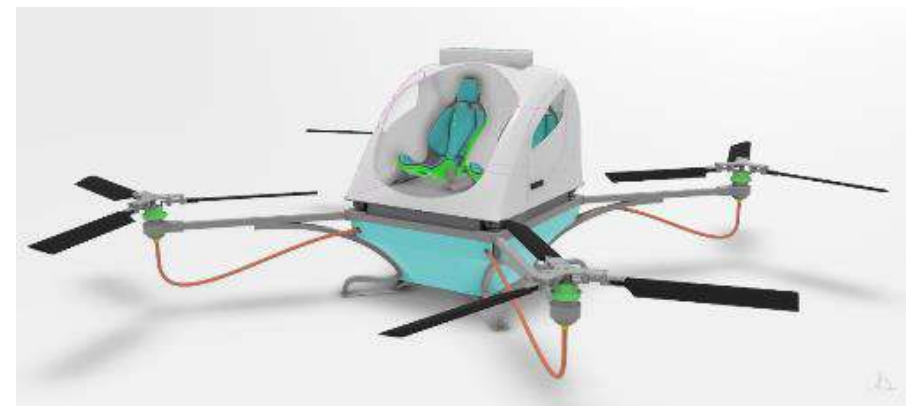

- Health Care
 - Drugs
 - Organ Transfer
- Agriculture
 - Irrigation, Fertigation and pesticide spraying
- Remote Sensing
 - Aerial Survey/Aerial Photogrammetry
 - LIDAR Survey
 - Weather Forecasting
 - Land use/Land cover prospective during disaster
 - Border security

Cabin Type	Cargo Cabin
Length	6 m
Width	6 m
Height	2 m
Engine type	Rotax 582UL
No.of Engines	2
Rotor diameter	1.2 Meters
No.of Rotors	6

3D Printer - Product Range

		Imaginator Lite	Imaginator Plus	Imaginator Ultra	Imaginator home
SN	Parameters	Specification	Specification	Specification	Specification
1	Technology	Fused Deposition Modeling	Fused Deposition Modeling	Fused Deposition Modeling	Fused Deposition Modeling
2	Print Size	160mm * 160mm * 160mm	200mm * 200mm * 200mm	300mm/250mm*300mm * 300mm	210mm * 210mm * 210mm
3	Compatible Materials	PLA, PET-G etc.	PLA, ABS, HIPS, PET-G etc.	PLA, ABS, HIPS, PET-G, Nylon etc.	PLA, ABS, HIPS Etc
4	Material Colors Available	More than 30 colors	More than 30 colors	More than 30 colors	More than 30 colors
5	Print Resolution	0.1 mm/100 Microns	0.1 mm/100 Microns	0.1 mm/100 Microns	0.1 mm/100 Microns
6	Hot-end Type	Single Extruder	Single Extruder	Single/Dual Extruder	Single Extruder
7	Nozzle-Type	Brass	Brass	Brass	Brass
8	Nozzle Max. Temp.	260°C	260°C	260°C	260°C
9	Working Ambient Temp.	15-40°C	15-40°C	15-40°C	15-40°C
10	Connectivity	SD-Card/USB	SD-Card/USB	SD-Card/USB/Wi-Fi(Optional)	SD-Card/USB
11	Power	Input Voltage : 220 V,50Hz Input Current : 5-6 Amp.	Input Voltage : 220 V, 50Hz Input Current : 5-6 Amp.	Input Voltage : 220 V,50Hz Input Current : 5-6 Amp.	Input Voltage: 220 V, 50Hz Input Current: 5-6 Amp.
13	Max. Bed Temp.		100°C	100°C	100°C



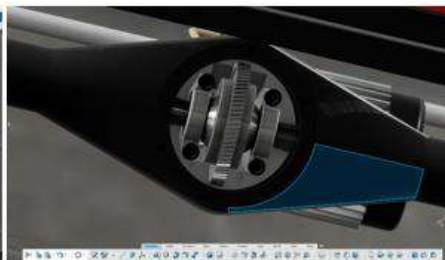
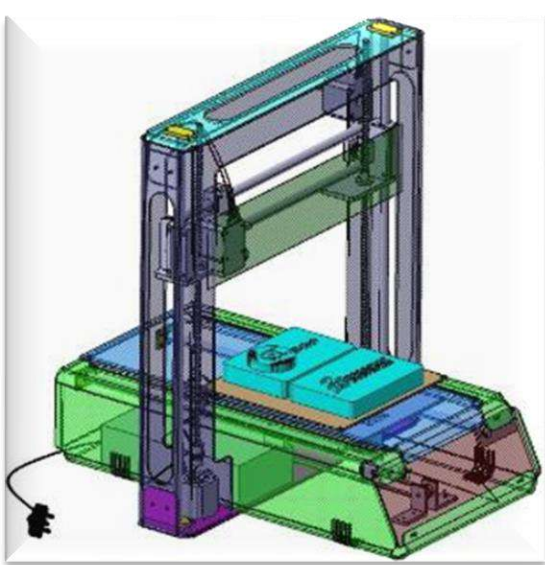

Scope

- Digital Product Design
- Market study of Problem Statement
- Tear Down and Bench Marking
- Concept Design
- Basic Hand calculation
- Product Costing & Target Cost
- Product Design – System & Subsystem
- Product Integration
- System Engineering - Mech – EE – ECE
- Design Review – Virtual Reality
- Simultaneous Engineering
- Design Optimisation
- Prototyping

Technology/Software

- 3D EXPERIENCE Platform of DS
- CATIA (Sketcher, Part design, Drafting, Assembly, Remastering, Welding design)
- CATIA Sheet metal Design
- CATIA Live Rendering
- CATIA ICEM Surface Design
- CATIA BIW Design
- DYMOLA

Product Design

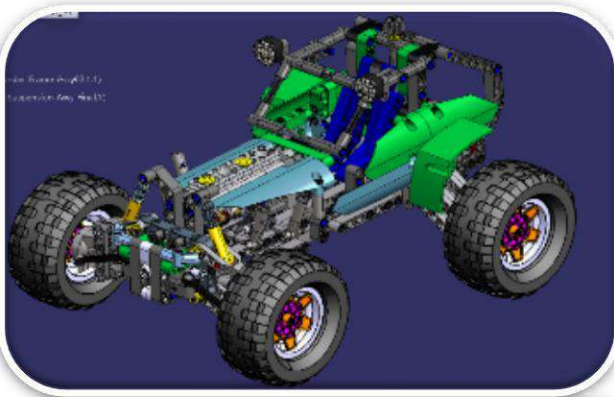

Scope

- ❖ Design and development of:-
 - E-Bike
 - Over Head Water Tank
 - Assistant Robot
 - Metal 3D Printer Machine by Supersonic concept
 - Fire Fighter Drone
 - Mini Satellite
 - semi autonomous wheel chair
 - PVC Printing

Services Offered

- Product Designer
- CAE Analyst
- Startup
- Consultancy
- Design Developer
- Project Manager
- Automotive Industries

Case Studies – Products Developed



Electric Vehicle



eRickshaw



Foot Over Bridge



Admin Building -BIM



Digital Factory - EV

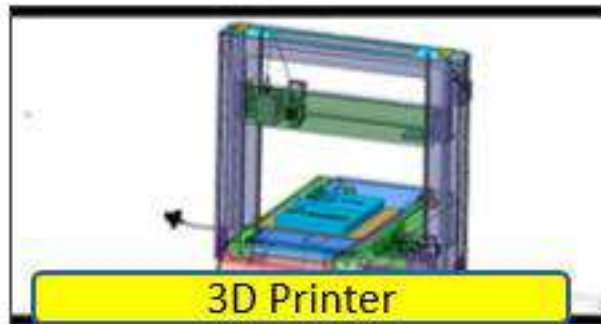

3D Printer

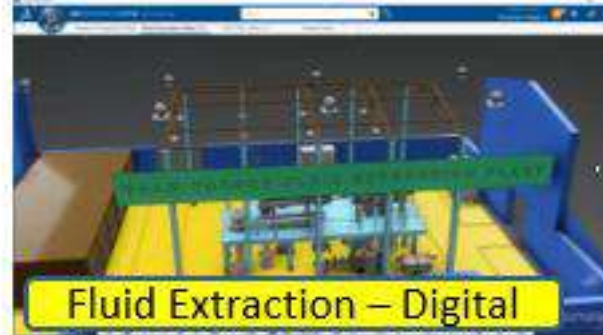

Fluid Extraction – Digital



Pick & Place Robotics

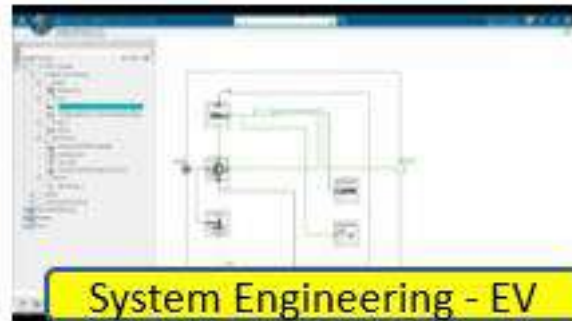

System Engineering - EV



Rice Mill – Digital Twin

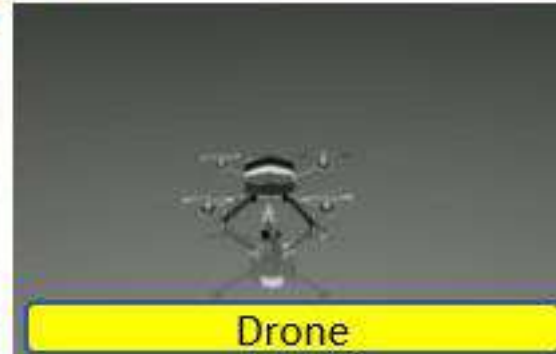

Drone

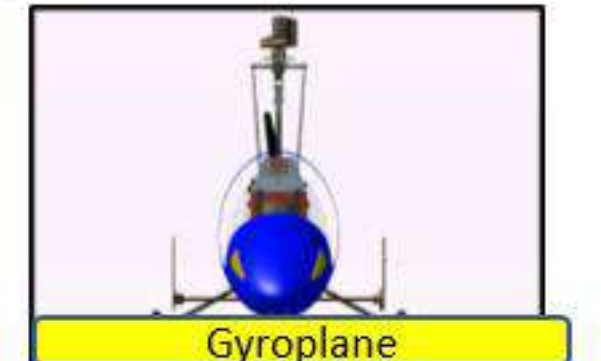

Gyroplane

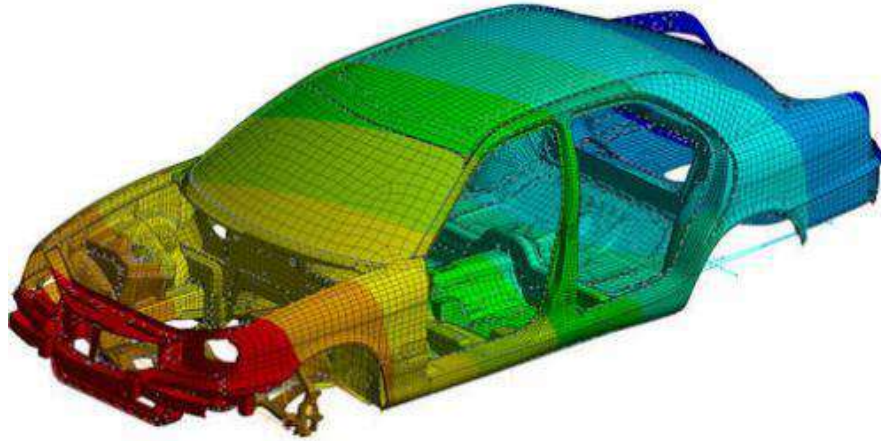

Meshing of Monocoque chassis

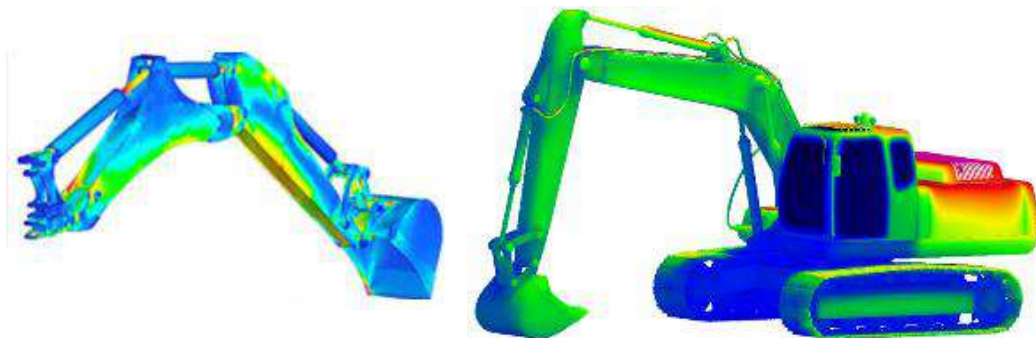

Static load analysis of Heavy vehicle

Learning

- Overview of Finite Element Analysis
- Stage of Analysis
 - ✓ Pre-Processing - 2D & 3D Meshing, Material Assignment, Load cases
 - ✓ Solving – Solving on Abaqus, Simulia
 - ✓ Post-Processing – Result evaluation, Stress & Strain graph
- Types of Analysis
 - ✓ Static load Analysis
 - ✓ Service Level Analysis
 - ✓ Dynamic Load Analysis- Apply constraint during simulation, Apply material properties, Observe behavior of the suspension of E-Bike.
- Overview on Computational Fluid Dynamics (CFD) Analysis- Numerical analysis, Data structure to analyze fluid flow behavior, Study of Mesh of CFD.

Technology/Software

- 3DEXPERIENCE Platform of Dassault Systemes
- SIMULIA – Structural model, Structural Scenario, Mechanical scenario, structural validation, Durability validation, Fluid model, physics results.
- ABAQUS CAE

Product Validation

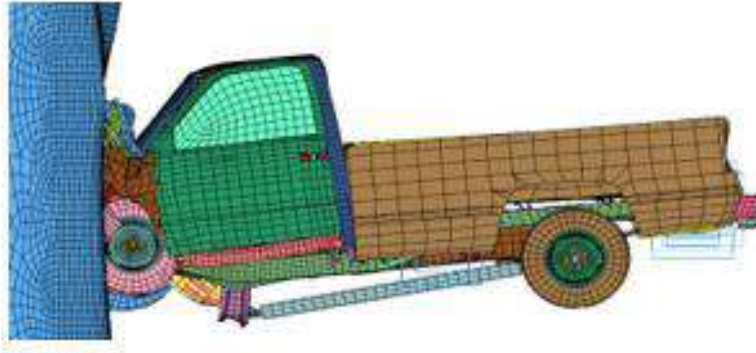

Crash analysis of vehicle

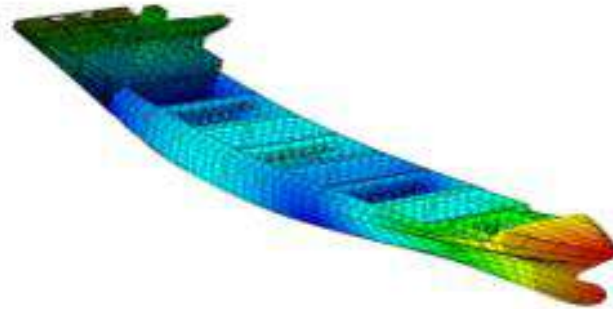

Structural analysis of ship



Structural analysis of Bi-cycle

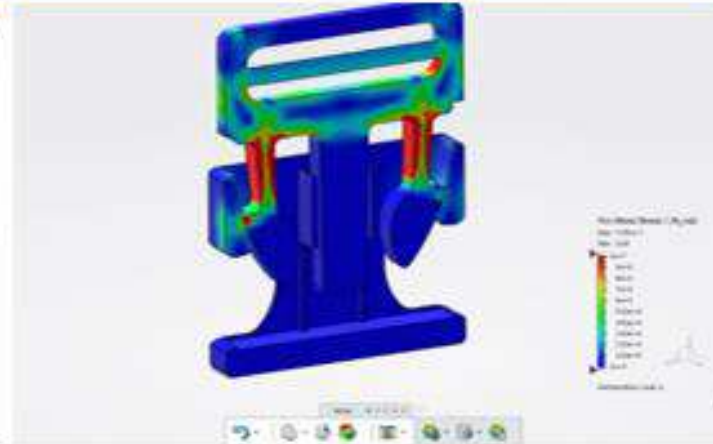

Structural analysis of Buckle

Scope

- Durability Analyst of the product.
- SLA analysis of Vehicle.
- NVH analysis of product.
- Crash Analysis of product.
- Static Load Analysis.
- Linear and Non-linear Analysis
- Advance Meshing of the product.
- Fatigue Life Analysis.
- CFD and Thermal Analysis.

Services Offered

- CAE Analyst
- Durability Analyst
- CAE-Analyst –Crash
- Ready to work with OEM- Automotive, Aero, Heavy Equipment, Marine & Ship Building Process Industry, Heavy Machinery and their Tier-1, Tier-2 and suppliers



Smart city Planning



Road mapping & GIS

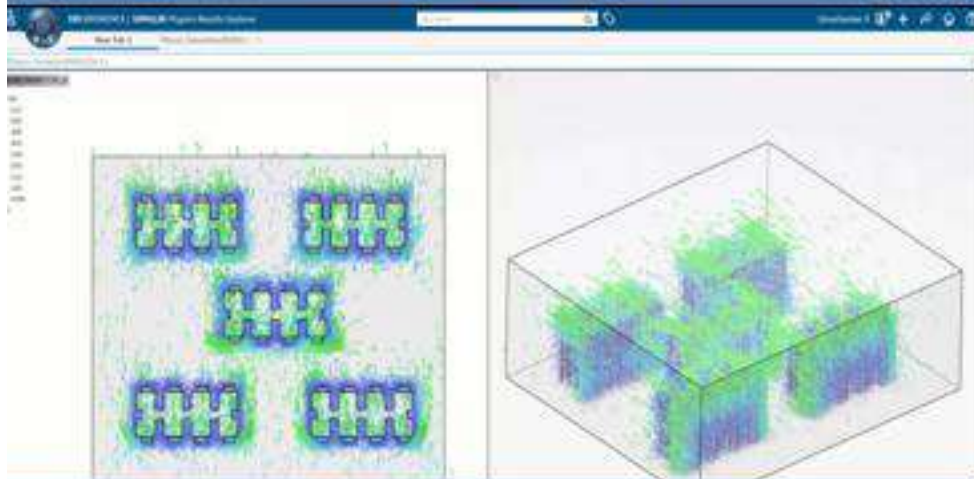

Various Load Analysis

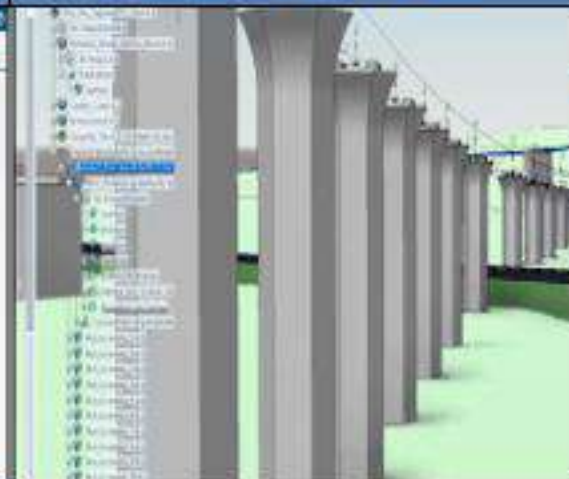

Rigid structure Design

Learning

- ✓ Building Information Model
 - ✓ Foundation
 - ✓ Building Structure
 - ✓ Roof Framing
- ✓ Interior Designing
- ✓ Plumbing & Piping
- ✓ Simulation & Analysis
 - ✓ Live Load
 - ✓ Seismic Load
 - ✓ Dead
 - ✓ Wind load

Technology/Software

- ✓ 3DEXPERIENCE Platform of Dassault Systemes
- ✓ Catia, Enovia, Simulia, 3D Excite
- ✓ Part Design, Assembly Design, Structural scenario, Structural Simulation.
- ✓ Building Structure Design
- ✓ Civil assembly design
- ✓ Architectural, Engineering & Construction
- ✓ Building and Civil Assembly



Walk Through of Foot Over Bridge

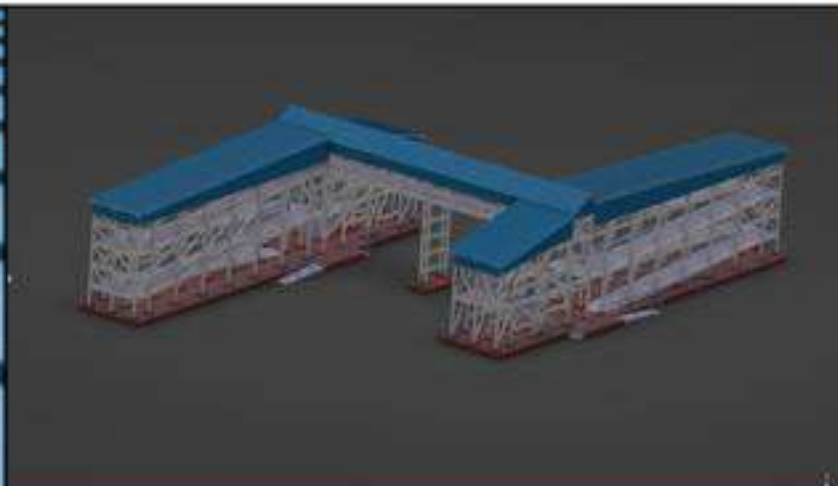

Reverse engineering of Foot Over Bridge

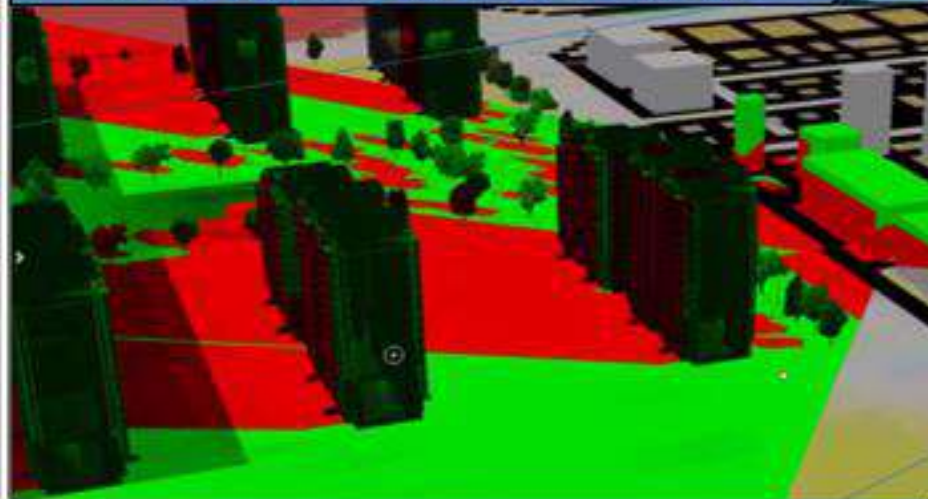

Shadow Analysis

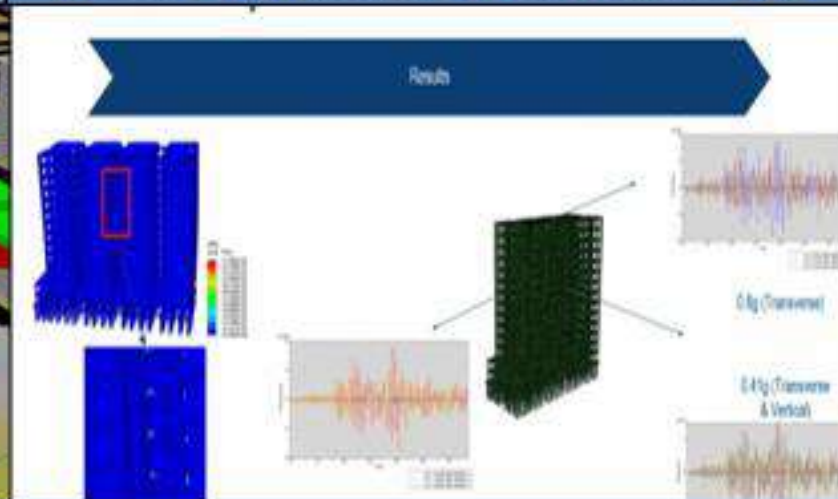

Seismic analysis

Scope

- ✓ BIM Modelling
- ✓ Digital Twin of Smart city
- ✓ Structure Simulation
- ✓ Surface Modelling
- ✓ Terrain Preparation
- ✓ GIS Mapping
- ✓ LIDAR Technology and Survey

Digital Twin / 3D Digital FACTORY

- Layout & Space validation
- Material & Resource Planning
- Modelling of facilities and resources.
- 3D Walkthrough
- Clash report generation between civil structure & planned resources
- Described and labelled AVI including all shops and area visualization.
- Providing recommendations & solutions for improvement

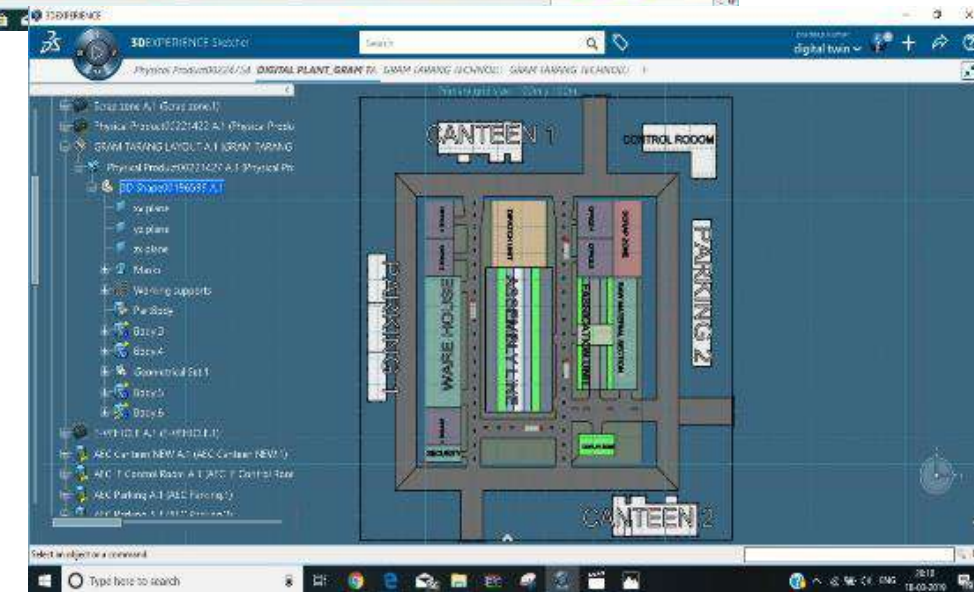
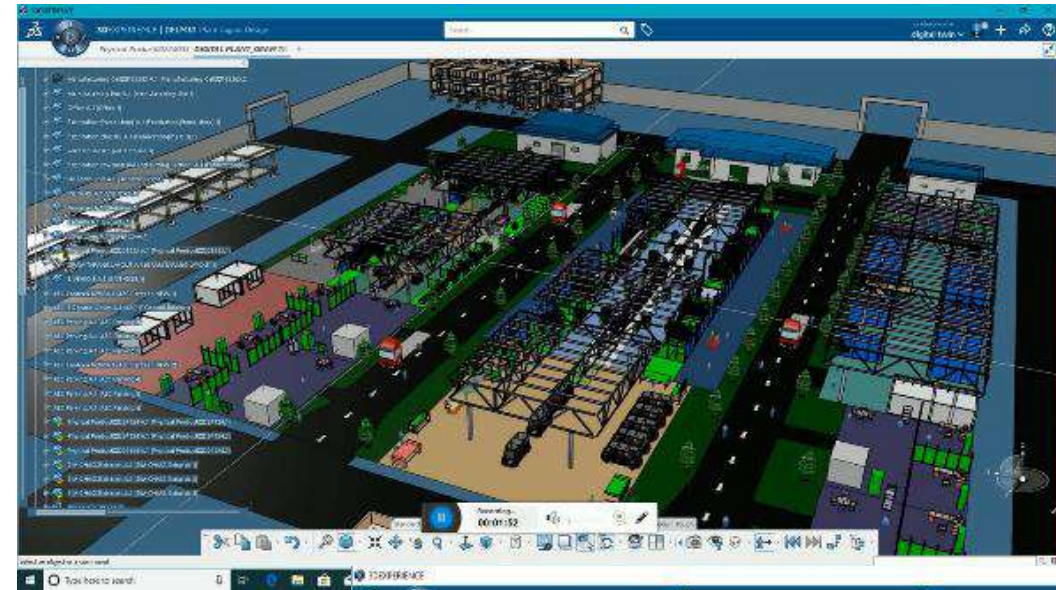

Process Planning

- Process Planning
- Line Balancing, Load Balancing
- Variant Management & Change management
- MOST: Maynard Operation Sequence Technique
- Worker Ergo-index & Skill Matrix
- Shop Documentation : Process Sheet/SOP

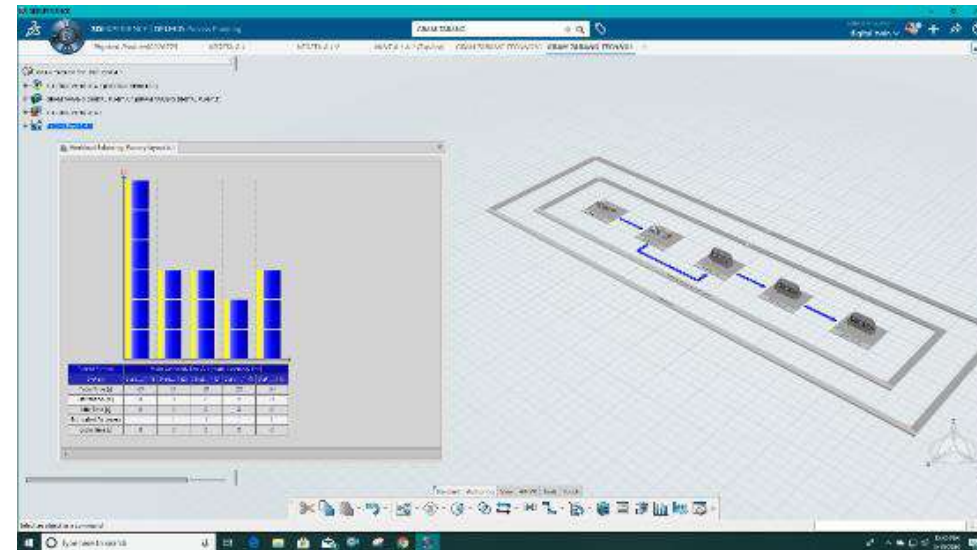
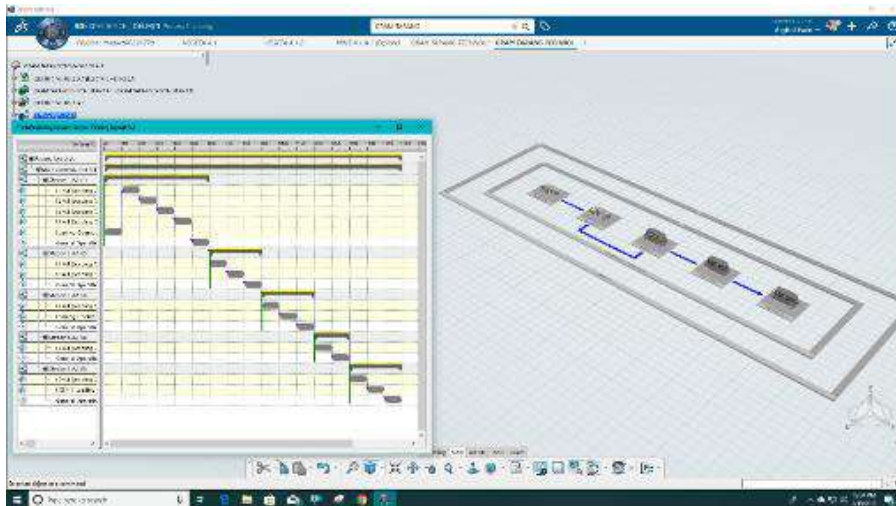
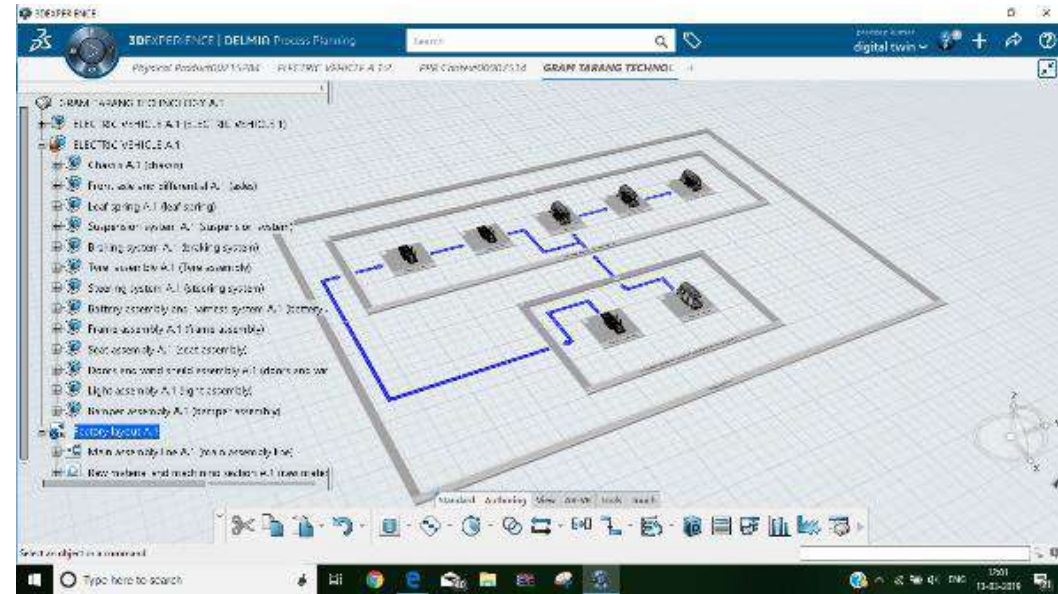

Process Simulation

- Product and resource validation (Clash, collision and interference analysis)
- Process sequence verification
- Assembly process simulation
- Digital Mock-up of the product
- Operator safety and ergonomics check for operators by using RULA analysis
- Validations with tools
- Proving recommendations & solutions



Human Simulation

- Clash detection
- Analyse Lifting/Lowering /Pushing/Pulling/Carrying
- Lifting analysis by using NIOSH technique
- RULA, update colouring during simulation
- Balance computation, Biomechanics
- Compute Energy expenditure for a series of activities Using Garg's equation

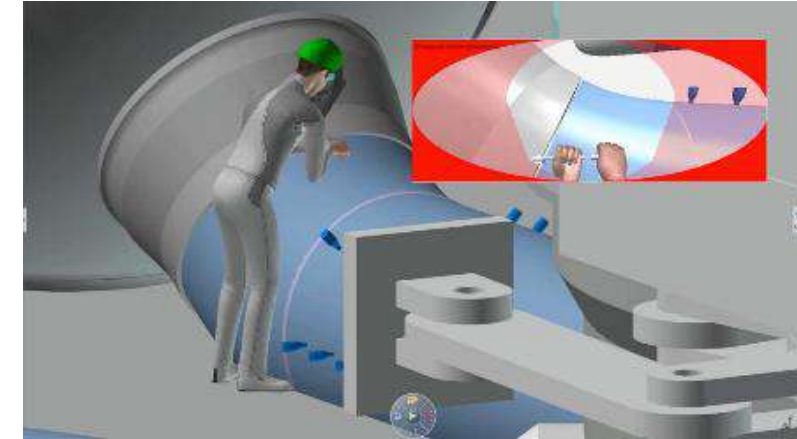
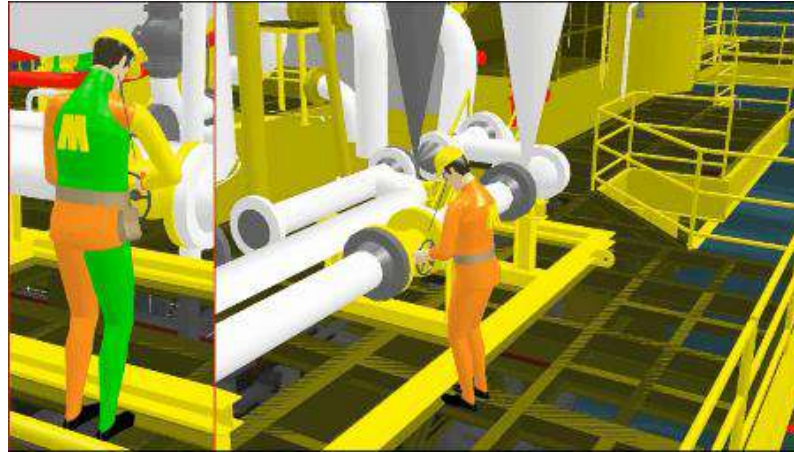

Customisation Area of Dassault Systemes Solution

Programming Language

EKL

Enterprise Knowledge Language

Allows you to construct smart-models and automate design for maximum productivity

VB Script

Import/Export data in template

KBE

VB Script

CAA

Low Level

Moderate Level

Complex Level

Dassault System Solution



3DEXPERIENCE Platform



ENOVIA



CATIA



DELMIA

Other Native Brands

KBE

Knowledge Based Engineering

Programming Language

Java

BPS-Business Processes Services web application, web user interface, Customization etc

CAA (C++)

Component Application Architecture

To integrate their components within 3DEXPERIENCE using existing 3DEXPERIENCE objects, how to develop new applications and deliver them to the customer

GEOVIA Solution



GEOLOGY AND MINE PLANNING



GEOVIA | Surpac

Surpac is the world's most popular geology and mine planning software. It delivers efficiency and accuracy through ease-of-use, powerful 3D graphics and workflow automation.

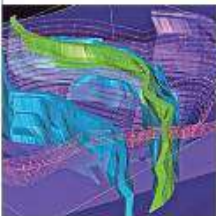

GEOVIA | GEMS

GEMS provides collaborative geology and mine planning capabilities that support cross-functional teams involved in exploration, modeling, mine design, long-term planning and production scheduling.

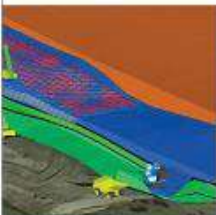

GEOVIA | Minex

Minex provides the best geology and mine planning tools for coal and other stratified deposits, ensuring resources are evaluated accurately and mined efficiently.

BLOCK CAVING

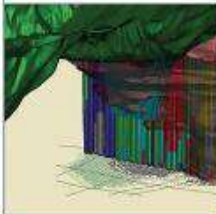

GEOVIA | PCBC

PCBC is used by virtually every major mining company involved in block caving, who rely on its comprehensive functionality to assist with feasibility studies, design and production management.

STRATEGIC MINE PLANNING

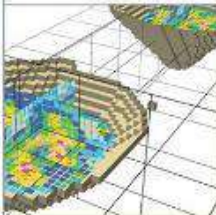

GEOVIA | Whittle

Whittle is the world's most trusted strategic mine planning software used to determine and optimise the economics of open pit mining projects.

SCHEDULING



GEOVIA | MineSched

MineSched – The most innovative scheduling software experience for mining puts you back in the driver's seat to maximize productivity and profits.

MINE PRODUCTION MANAGEMENT AND RECONCILIATION



GEOVIA | InSite

InSite collates all aspects of production activities against a production plan. Advanced reconciliation tools allow mining operations to address and understand the cause of variance.

SECURE REMOTE COLLABORATION



GEOVIA | Hub

Hub provides a secure collaboration environment that organizes and enables the reliable sharing of exploration, planning, and production data over low-bandwidth connections.

SERVICES



GEOVIA | Services

When you don't have the time or in-house resources available, GEOVIA's global Services team can provide geology, engineering, and operations assistance.

Biovia Solution Implementation and services

BIOVIA Solutions:

- Molecular Modeling of Drugs and Validation
- Gene manipulation and designing of new modified genes
- Pharmacophore modeling and validation
- Designing of new fuel
- Designing of bio-metals and validation
- Machine learning for crop yield identification

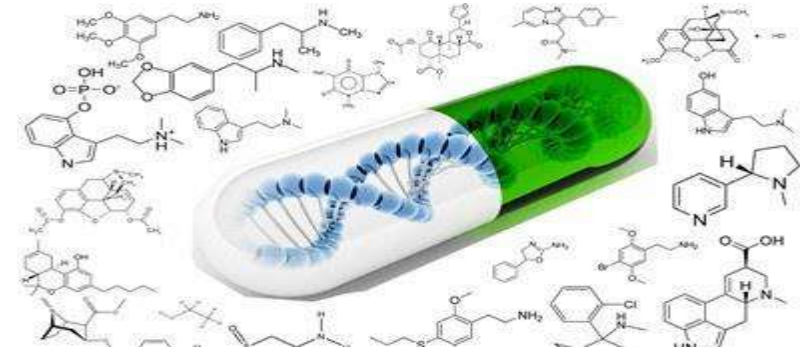

GLBRC Research: With sustainability as an overarching theme, GLBRC scientists and engineers are using each plant cell component, chemical intermediate, and building block to help replace fossil fuels and other petroleum products while adding value to the biofuels production chain. (Image by Matthew Wisniewski, GLBRC)

Augmented & Virtual Reality

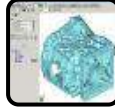
 CAD Data

- Export CAD data
- Model Preparation.

 Import Model

- Post-Processing of model
- Texturing

 Light & Shadow

- Light analysis and Preparation
- Color Correction of Scene

 Mechanics & Interactivity

- Behavior Programming
- Interaction Programming

 Testing & Building

- Unit Testing
- AR-VR Platform Building

Virtual Reality



VR teleports a user to a **Virtual World** generated by Computer Graphics using Smart Glasses and VR HMD.

Augmented Reality



AR renders **Digital Models on Real World** using Handheld Devices and Holo Glasses

Content Creation and Services to Industries: Automotive, Medical, Manufacturing Safety Precautions, Product Marketing

4

Interventions in Agriculture

Lab to Land: Taking skills &
technology to the farmers



*Rich bio-diversity on the campus - 4527 trees in the JITM campus - including
1100 mango trees, 2407 teak trees & a mix of fruit bearing trees
The CIT campus houses over 2175 plants with 51 varieties of fruit trees,
ornamental plants, nuts & spices*



REVOLUTIONIZING THE AGE-OLD: AGRICULTURAL INNOVATION & OUTREACH

Under the aegis of the M.S. Swaminathan School of Agriculture [Paralakhemundi campus], innovative, hands-on, experiential training & production is being developed in a diverse range of agricultural and allied activities.



MS Swaminathan School of Agriculture Sciences

- VERMI COMPOST PRODUCTION UNIT
- BIO FERTILIZER UNIT
- PLANT TISSUE CULTURE & RESEARCH
- HYDROPONICS LABORATORY
- SEED PROCESSING UNIT
- ORGANIC RESEARCH FARM
- MUSHROOM CULTIVATION
- ANIMAL HUSBANDRY, LIVESTOCK & MINI DAIRY
- WATERSHED DEVELOPMENT
- SUPER CRITICAL CO2 FLUID EXTRACTION



Plant Tissue Culture using micro-propagation in the Bio Tech Lab



A 12,000 sq ft. poly house to grow high value plants – ornamental & medicinal



INTEGRATING AND ENHANCING ENGAGEMENT WITH THE FARMING COMMUNITY

An **Organic Research Farm** was set up to conduct research with organic nutrients & pesticides produced by the composting unit – the learnings of which can be cascaded to the field.

Plant Biotechnology laboratory with two wings - Plant tissue culture and Plant Molecular Biology that includes **Hi-tech Poly-house, Green-shelters and Polythene-shelters** was set up in 2016-2017 with state-of-the-art facilities and involved in various *in vitro* and *ex vitro* activities.





Model Herbal Medicine Garden with 146 varieties of medicinal herbs was set up. Regular outreach in the nearby communities farming through farmer training programmes on topics like vermicomposting, mushroom & tomato cultivation, organic growing etc. Encouraging agri-entrepreneurs to take up micro-propagation of medicinal plants, ornamental trees, horticultural and floricultural crops and production of pharmaceutically interesting compounds.

Project I Summary: Skilling 1 Lakh Farmers

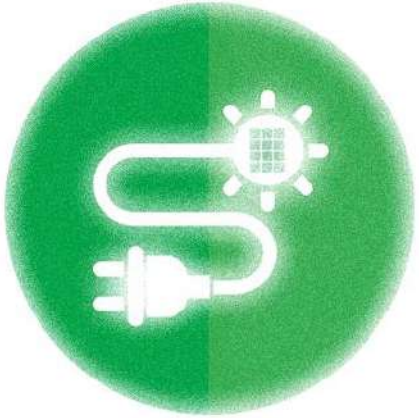

Project Objective:

This project aims to develop a scalable, sustainable training-cum-production model that creates social infrastructure and leverages technology as well as market intelligence to equip farmers with locally relevant knowledge & skills resulting in enhancement of their income.

Project Goal: 100,000 farmers to be trained in 12 months

Perspective Shift: Each farm as an enterprise and farmer as an entrepreneur
Contributing to 'Doubling farmer Income (DFI) Goal' by 2022 of GoI

- The project envisions creation of Agri-Business Development Service Network (ABDSN) for training & certification of 1 lakh marginal farmers. The approach is to treat farms as enterprises and create a cadre of Krishi Udyog Sahayaks (Agriculture Development Service Providers) at grass root level across 200 blocks of Odisha.

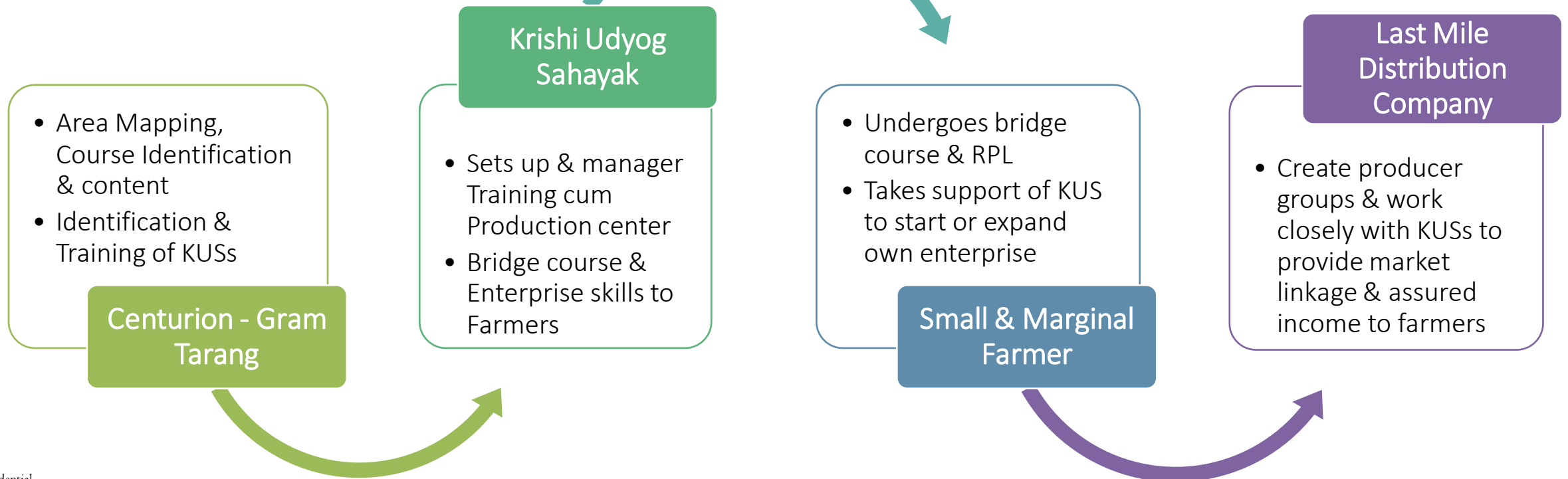

Job Roles & Districts

Sl.No	Job Role
1	Mushroom Grower
2	Solanaceous Crop Cultivator
3	Organic grower
4	Vermicompost Producer
5	Floriculturist
6	Tuber Crop Cultivator
7	Quality Seed Grower
8	Paddy Farmer
9	Citrus Fruit Grower
10	Pulses Cultivator
11	Maize Cultivator
12	Mango grower
13	Cotton Cultivator
14	Chillies Cultivator
15	Small poultry farmer
16	Dairy Farmer/ Entrepreneur
Grand Total	

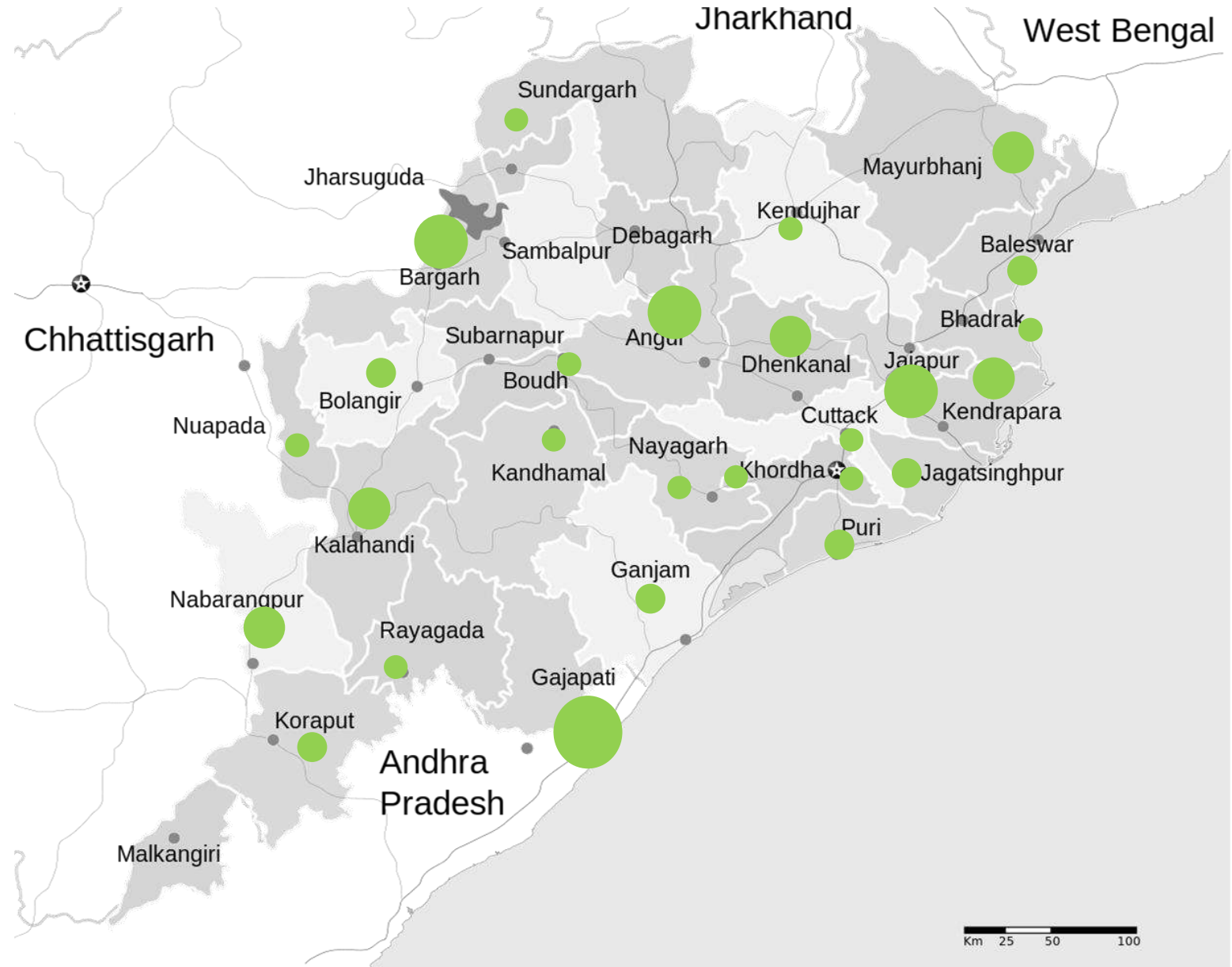

Farmer Experience Zone



Trainees in action



RPL Practical Training Sessions





Candidate Name : Krishna Bhoi
Job Role : Mushroom Grower
Location : Padampur, Baragarh
NGO Partner : Inclusive Action
KUS Name : Sushila Bhoi

Most of her village suffered from **distressed unskilled migration** to Hyderabad to work in brick kilns and were getting paid INR 150 for making 1,000 bricks. After the bridge course, during the non-cultivation period they are growing mushrooms and earning a decent living.

She is also happy that now she can pay the tuition fees of her children of her own

Supported by KUS Sushila Bhoi.



- Candidate Name : Netramani Mishra
- Job Role : Mushroom Grower
- Location : Astaranga, Puri
- Netramani Mishra (60 yrs) has 1 acre of land, after the training she prepared around 10 – 15 beds for mushroom, as taught to her by the **KUS, Damayanti Rout**.
- She invested Rs 80/- per kg of mushroom and she cultivated around 15 kgs of mushroom

RWI Hansapada, Puri: Floriculture

- **Mr. Manoranjan Bhoi** of Talapatak (Hansapada) Village in Chanarapada G.P of Nimapada Block in Puri district has created an example for cultivation of marigold flower after participating of 10 days RPL Training organised by RWI Hansapada.
- Leased 0.24 dcml land @ Rs. 3000/-per annum and cultivated marigold.
- Irrigated land from nearby water body by a motor pump set on hire Rs.100/-
- Prepared the land in 1st week of January 2019 and purchased 4,000 marigold plants from a nursery at Bhubaneswar @ Rs.1/- per plant (linked by KUS).
- Planted line by line according to the training and took care of the field properly assisted by his wife Kandhei and father Gunanidhi
- Flowers started blooming within 45 days of plantation
- Initially flower sold @Rs.0.25 per piece which went down to INR 0.2 per piece
- Due to low price the family made garland strings by and sold at local market @Rs.10/- per garland.
- Kandhei supported her husband and borrowed Rs.15000/- from her SHG.
- Investments:
 - INR 700 for hiring of tractor, INR 3,000 for manure, fertilizer, pesticide etc.
 - INR 4,000 for purchase of plants, INR 2,000 for irrigation,
 - INR 1,700 for boundary fencing, INR 3000 for land lease payment INR
 - INR 600 for other expenses.
- INR 25,000/- collected from sale of products by the end of March. Another





Candidate Name : Hemanta Sahu

Job Role : Solanaceous vegetables

Location : Singh Jharan, Bhawanipatna

NGO Partner : Antodaya NGO

Hemanta, 35 years, had monthly income of rupees 3,000 in a remote part of Kalahandi District. A class X dropout, instead of migration he opted for cultivation of leguminous crop, cabbage, cauliflower over about 1 acres of land apart from the paddy crop.

After training by KUS, he extended his vegetable cultivation land and grown okra, brinjal, pumpkin, amaranthus and other leafy vegetables. He has a deep bore well which got sanctioned during 2016-17, got functional in 2019 involving 8 farmers in their village. Now his monthly income from vegetable cultivation has increased to INR 8-10,000 per month



- **Manorama Mallick**, a Post Graduate student as well as the Sarpanch of **Gopalpur, Gram Panchayat, Balasore**.
- A charismatic leader and inspiring everyone to do something of their own. She also grows mushrooms after she got her training from Atal-RPL project, a project from NSDC, in partnership with Gram Tarang Employability and Training Services.
- She cultivates around 20 kg of mushroom from 10 beds and has begun supplying her produce in Balasore town. She is a good farmer, a better leader and the best inspiration for the people around her. She gathers people and motivates them to join various learning projects, where they can learn and know the vast knowledge of agriculture. She is trying very hard to make everyone's life better.

Seba Jagat, Kalahandi: Pulses & Tuber Cultivator

Candidate Name : Basanti Gahin
Job Role : Pulses Cultivator
Location : Kansil, Karlamunda, Kalahandi
NGO Partner : Seba Jagat



- By cultivating 4 quintals of toor dal and 3 quintals of moong. She was a trainee of RPL project; there she learned about pulse cultivation. The methods were new and exciting for her. Then she applied them in her farming, and got success. She is selling them for Rs60/- per kg. She is getting a lot more than she was getting previously when she was following the old methods. She now knows how to store the pulses without getting any insects into them. She is a member of a SHG formed with 200 female farmers, where they are buying moong and toor dal from other farmers at a rate of Rs50/- per kg and selling them in the local market at the rate of Rs60/- by keeping 20% as profit margin

Case study: Hamara Bachpan Trust (HBT), Astaranga, Puri: Mushroom Grower

- 50 member All-women batch trained for mushroom grower and floriculturist job roles.
- **KUS Damayanti Rout** helped trainees in making the beds for the mushroom and was present for handholding
- Average 10 beds per trainee yielding 1.5 kg per bed in 10-12 days
- Post harvest, trainees were given market linkages and distribution support
- Sale price INR 180-200 per kg on an input cost of INR 80 per bed or approx. INR 55 per kg



KUS Damayanti Rout



Project 2: Doubling farmer Income with Krishi Prahlad Initiative

- Government of India has taken up the ambitious target of Doubling Farmer Incomes (DFI) by 2022
- The focus is shifting from food production to treating farm as enterprise and farmer as entrepreneur
- Climate change has rendered ineffective and obsolete previously established manual processes and schedules for control of crop damage due to pests, diseases and drought.
- Urgent need for flexible pest damage detection and control solutions that are climate-resilient and adaptive to changing need

Crop field Multi-spectral Image

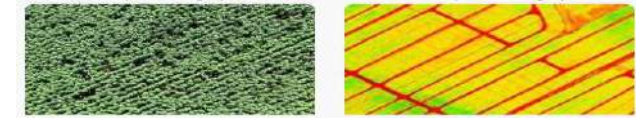

Mapping and prescription

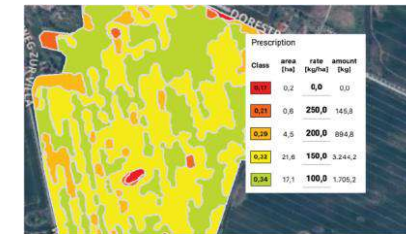

Precision Spray

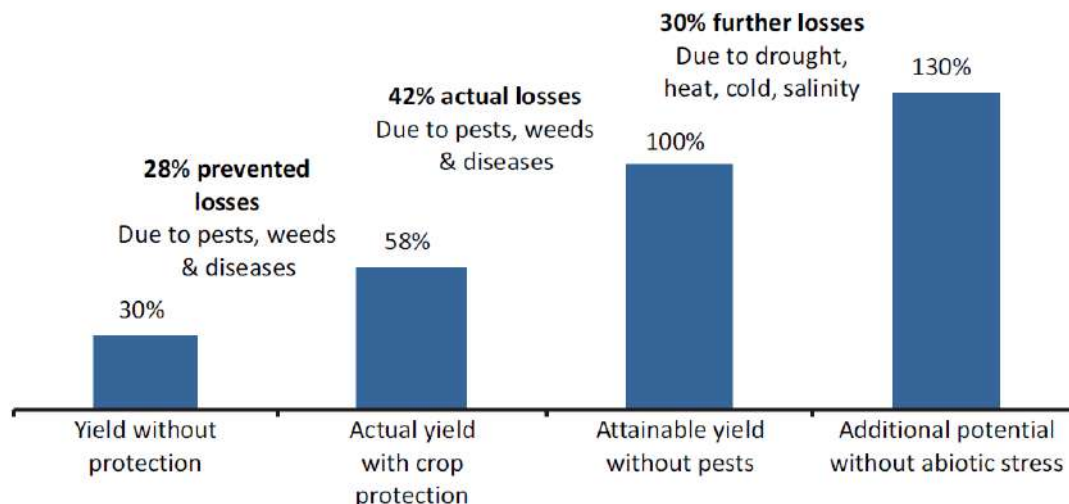

Problem Definition

- There is need to use better farm data management for improving the yield of farmers
- JPAL experiments (which have won them the recent noble prize in economics) has shown that 25% increase in yield is possible using precision agriculture advice and practices
- Such solutions are attempted at many places (ITC, IARI, New Delhi to name a few)
- This, coupled with an aggregation platform (Kalgudi or IFFCO KISAN app) can provide instant soil and crop health monitoring to farmers
- Couple this with Farmer Producer Organisations and Krishi Udyog Sahayaks in the field , this can be a potent business model with huge social impact.

Proposed Solution (codenamed as Krishi Prahlad)

- Farmer advisory service based on climate resilient agriculture practices using drones, AI and immersive extension:
 - Drone based Hyperspectral imagery to assess health of crop, soil & water
 - Artificial intelligence based Decision Making System (ADMS) to assess demand for water, nutrients and pesticide based on climatic conditions. This will determine fertigation control.
 - On demand, autonomous delivery as per ADMS requirements using Drone
 - VR/AR based immersive learning content
 - All such initiatives to be delivered through farmer advisory network called Krushi Udyog Sahayaks (KUS) . This will be delivered on an aggregation platform with IVR support too.
 - The whole solution to be branded as Krishi Prahlad initiative.
- Apart from using the ML based yield improvement model based advisory, Centurion University, with support from Dassault foundation, has developed 3d content based on VR/AR.
- The content is displayed in an experience on wheels van which moves from village to village
- The farmer is introduced to new protected agriculture and other methods through immersive learning content

Envisaged Work-Flow

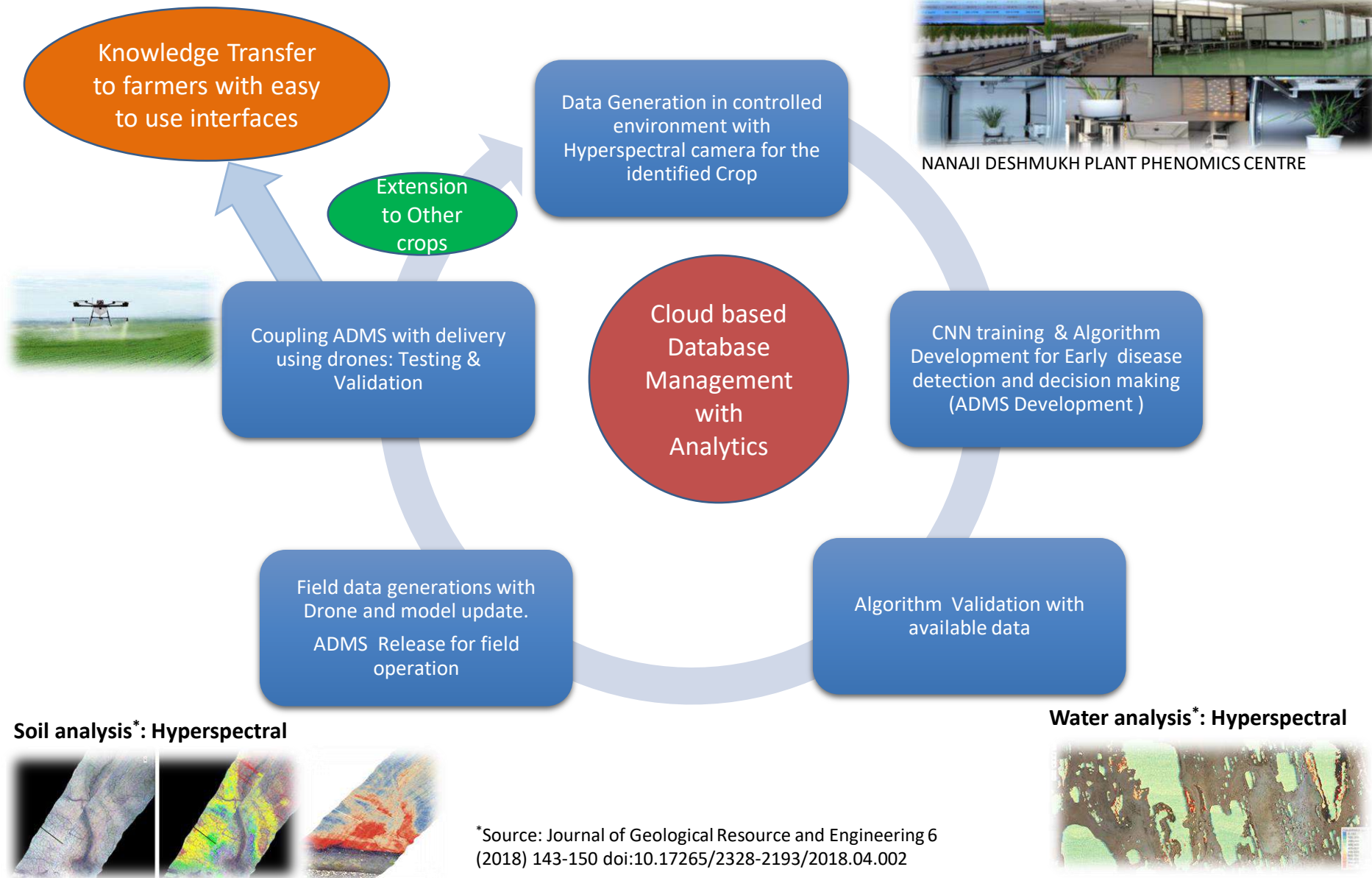



Farmers Experience Zone on wheels

Our operating model in the field

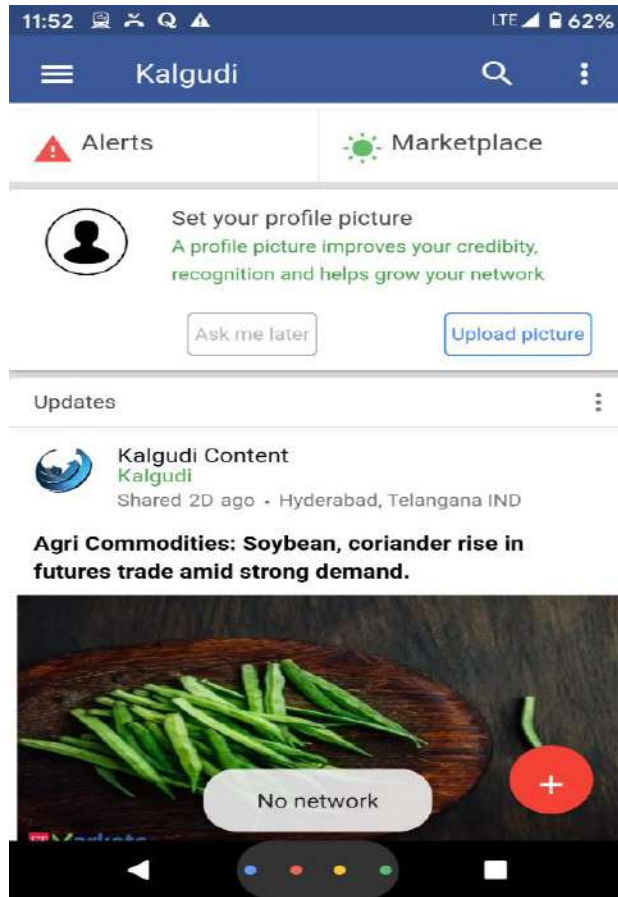

Krishi Prahlad
AI model, drones,
AR/VR content

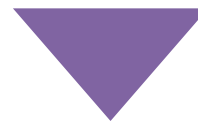

KRISHI UDYOG SAHAYAK
Supported by Kalgudi Platform
(FACILITATED BY CENTURION)



**GOVERNMENT/
FARMERS
COMMUNITIES/
Farmer Producer
Companies**

- A Proof-of-Concept sprayer-UAV prototype has been successfully field tested in actual palm-crop orchards in partnership with Central Plantation Crop Research Institute (CPCRI)
- An app based farmer advisory service to the farmers is going to be developed by Centurion University using Dassault systemes Pipeline pilot tool
- The app will use ML algorithm for predicting yield given the major and minor nutrient content of the soils and the farmers inputs
- The app is being developed for field crops as well as protected agriculture crops
- While fertigation will be controlled for field crops, fertigation based on humidity and temperature along with soil nutrients will be controlled for crop under protected agriculture crops.

తెల్లదోమకు 'డ్రోన్'తో చెక్

కడియం (రాజమహేంద్రవరం రూరల్): సర్పిలాకార తెల్లదోమ నివారణకు డ్రోన్ టెక్నాలజీ వినియోగంపై మండలంలోని నర్సరీ రైతులకు గురువారం అవగాహన కల్పించారు. కడియపు లంక గట్టి వెంకటరమణ నర్సరీ వద్ద ఏర్పాటు చేసిన ఈ కార్యక్రమంలో సుమారు 40 అడుగులకు పైగా ఉన్న కొబ్బరిచెట్లపై పిచికారీ చేసుకునేందుకు డ్రోన్ ఏ విధంగా ఉపయోగపడుతుందో వివరించారు. ఈ సందర్భంగా ఏర్పాటు చేసిన కార్యక్రమంలో సీపీసీఆర్ఐ డైరెక్టర్ డాక్టర్ చౌడప్ప ముఖ్య అతిథిగా పాల్గొని మాట్లాడారు. తెల్లదోమ నివారణకు అందుబాటులో ఉన్న అన్ని విధానాలను అమలు చేయాల్సిన అవసరముందన్నారు. అందులో భాగంగా డ్రోన్ టెక్నాలజీ ఎంతవరకూ ఉపయోగపడుతుందన్న దానిపై ప్రదర్శన ఏర్పాటు చేసినట్లు చెప్పారు. సాధారణంగా ఒక ఎకరాకు ప్రస్తుతం వాడుతున్న స్ప్రేయర్లతో 200-250 లీటర్ల నీటిని పిచికారీ చేయాల్సి ఉంటుందన్నారు. డ్రోన్లో వినియోగించిన అదునాతన నాజిల్స్ ద్వారా కేవలం అరు లీటర్ల ద్రావణం సరిపోతుందన్నారు. నానో పార్టికల్స్ రూపంలో ద్రావణం చల్లబడుతుందన్నారు. తెల్లదోమ నివారణకు వినియోగించే వేపనూనె తదితర వాటిని ఎత్తైన మొక్కలపై చల్లేందుకు డ్రోన్ ఎంత వరకూ ఉపయోగపడుతుందన్న దానిపై ఈ కార్యక్రమం ఏర్పాటు



- అధునాతన టెక్నాలజీపై అవగాహన
- హాజరైన సీపీసీఆర్ఐ డైరెక్టర్ డాక్టర్ చౌడప్ప
- ఆసక్తిగా తిలకించిన నర్సరీ రైతులు

షేక్ బర్బన్ రైతులకు వివరంగా రైతులు, అధికారియన సమాధానాలిచ్చారు. స్థానిక నర్సరీ రైతులు ఆ ఇండియన్ నర్సరీ ఫార్మర్స్ ఖైదు పల్ల సుబ్రహ్మణ్యం ఫార్మర్స్ అసోసియేషన్ అనారాయణ (చంటి), బి.డి.ఎం.సింగ్, ఏపీఎం ఐపీఎం ఏడీహెచ్ కె.విట్టిబాబు, డైరెక్టర్ యూనివర్సిటీ రీసెర్చ్

పిచికారీకి డ్రోన్ల వినియోగం

అధునిక పద్ధతులతో అధిక లాభాలు
 డ్రోన్ల వినియోగం పంటలకు తెలుసుకుంటున్న రైతులు
 కడియం (రాజమహేంద్రవరం రూరల్): అధునిక పద్ధతులతో అధిక లాభాలు పొందేలా రైతులకు తెలుసుకుంటున్న రైతులు...
 డ్రోన్ల వినియోగం పంటలకు తెలుసుకుంటున్న రైతులు...
 డ్రోన్ల వినియోగం పంటలకు తెలుసుకుంటున్న రైతులు...



డ్రోన్ వినియోగం పంటలకు తెలుసుకుంటున్న రైతులు

Lab to Land to Market

High GI vs Low GI Foods

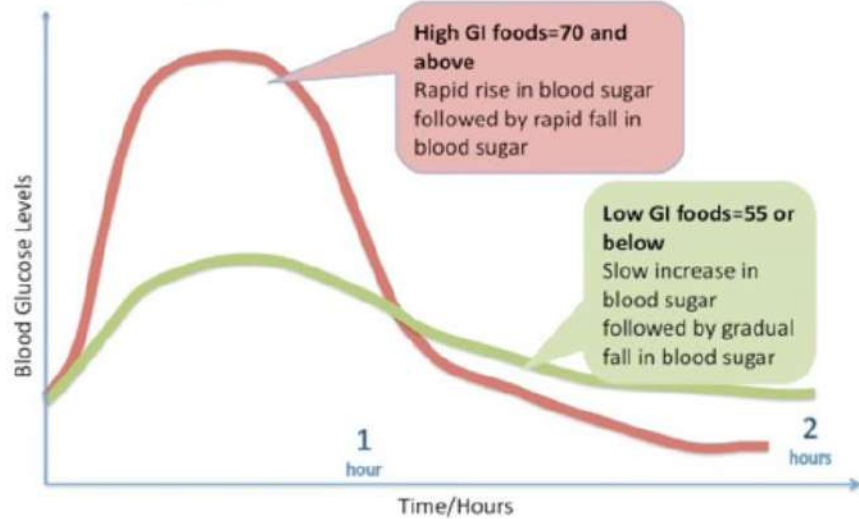

5



Lernern
Shaping Futures

Work Integrated Skill Training & Apprenticeship

The Gram Tarang portfolio continuum has helped build confidence among industry & the “Blue Collar” target group

2006



Long term Skill Development

- Deliver long term training resulting in Vocational
- Education Qualifications
- Paid courses with multiple entries and exits
- Operate and manage 6 ITIs (2 ranked top 10 in India) & 4 Polytechnics
- 2,000 Trainees per annum



2010



Short term Skill Development

- Short term residential training programs
- Mainly government sponsored programs
- Also implementing a large scale (1 lakh+ farmer) project in Odisha
- 35 Centers, 20,000 Trainees per annum



2015



Work Integrated Programs & Staffing Solutions

- Qualifications for migrant workers @ hostels
- Industry Partnerships
- Provision of NSQF linked training in over 640 government schools in 10 states
- 3,000+ manpower deployed with over 40 sites



2020



Further education & EdTech for blue collar

- 10,000 headcount with 1,000 active learners
- Sectors range from auto component manufacturing units to eCommerce (Big Basket, Zomato, Flipkart, Vogo)



Shift from brick and mortar skilling to technology enabled blended learn

Shaping blue collar futures...



Lernern is the EdTech arm of **Gram Tarang Technical Vocational Education & Training Pvt. Ltd** (GTVET), a high-performance blue-collar staffing services, skills training & apprenticeships provider working towards its mission of making technology enabled learning for all. The company is especially focused on those at the bottom of the pyramid and primed to touch 1 million users by 2025. It has been incubated under *Startup Odisha* at Centurion University, a leading Skills University.

Tracing its roots to the premium skill development company in India, the founders of **Lernern** have extensive expertise in grassroots level community mobilization, delivery of technical vocational education & training through short, medium & long term courses, setting up & managing a skills university, large scale Pan India skill assessments and operating an accredited **Center of Excellence**.

Having trained over 350,000 & meaningfully engaged over 200,000 blue-collar workers for placements in a wide range of industries or into self-employment, the founders have received world-wide acclaim by UN agencies, British Council, ADB, World Bank, NITI Aayog, NSDC, MSDE et al as a model for emerging economies.

The team has pioneered a '**Work integrated Skill Training & Apprenticeship**' program which enables further education for blue collar workers in India through the dual model by integrating academia & vocational education with industry. Blue collar workers enroll for various courses on the technology platform accredited by Directorate General of Training (DGT) & Skills Universities which enable accumulation of credits towards higher qualifications while working.

Several pilots have been on the ground since 2015 in industrial clusters of Bangalore, Coimbatore, Pune and NCR with leading industry partners like Café Coffee Day, Haier, Carrier Media etc. The employer benefits through better retention, increased labour productivity and many have willingly co-sponsored the training fee. The Covid pandemic gave **Lernern** the opportunity to develop a technology platform which enabled a quicker scale up of the programs. Presently Lernern works with 200+ industry partners and has 15,000 active users enrolled working towards an overall vision of 1 million active users by 2027.

Taking our youth from where they are to where they aspire to be...



Sonalisa, Jajpur district,
Batch 37, 2015
Manages the airport café at
Chandigarh, enrolled for
work integrated BBA

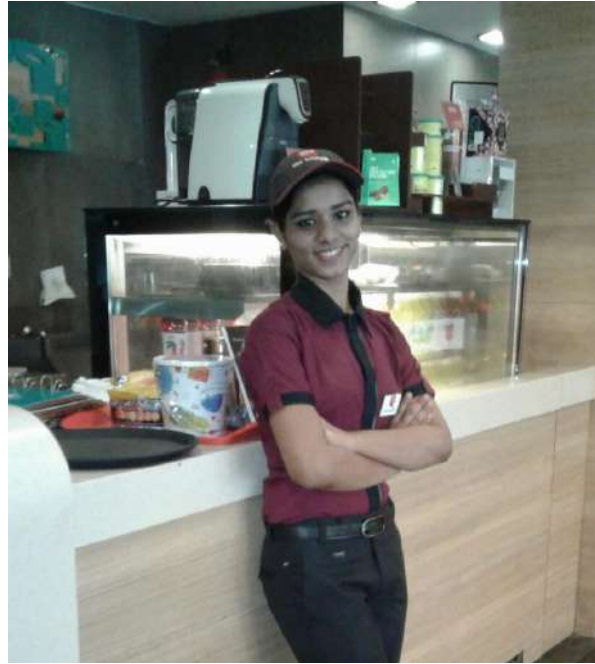

Maushumee Hota, Ganjam
district, Batch 23, 2014;
Manages a CCD Lounge in
Chennai, in 2nd year of work
integrated BBA



Satya Ranjan Behera, ITI
MMV (2013)
Quality in charge at
Oerlikon Graziano,
Gujarat; Interested in
pursuing Diploma



Saddam Ansari, ITI Fitter
(2011)
Sr Technician, Bhilai Steel
Plant Chhattisgarh;
Interested in pursuing
Diploma

Common thread binding Sonalisa, Maushumee, Satya & Ansari: They were skilled at Gram Tarang placed in the industry and have enrolled or are aspiring for higher education programs with Centurion University

Linking skilling, education with career progression



Program Flow

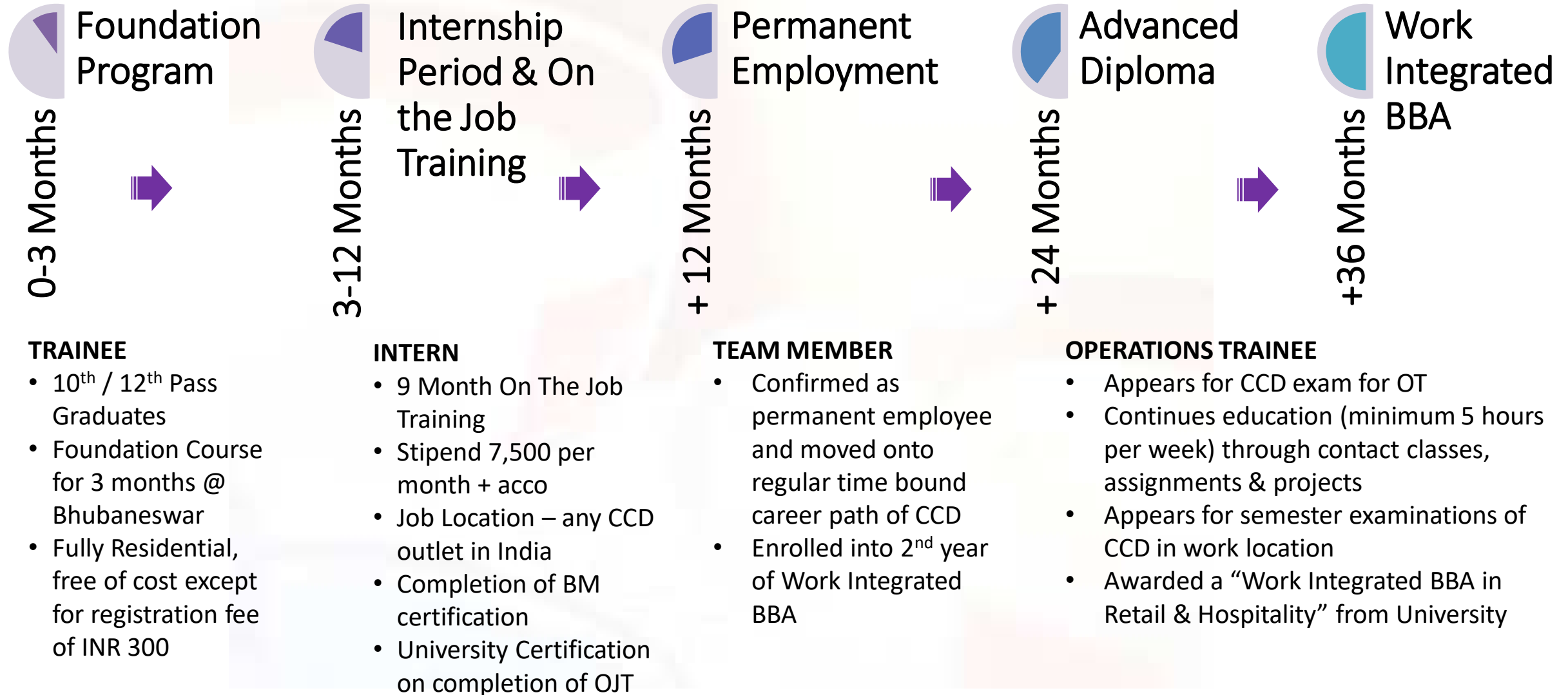

Career pathing through work integrated learning

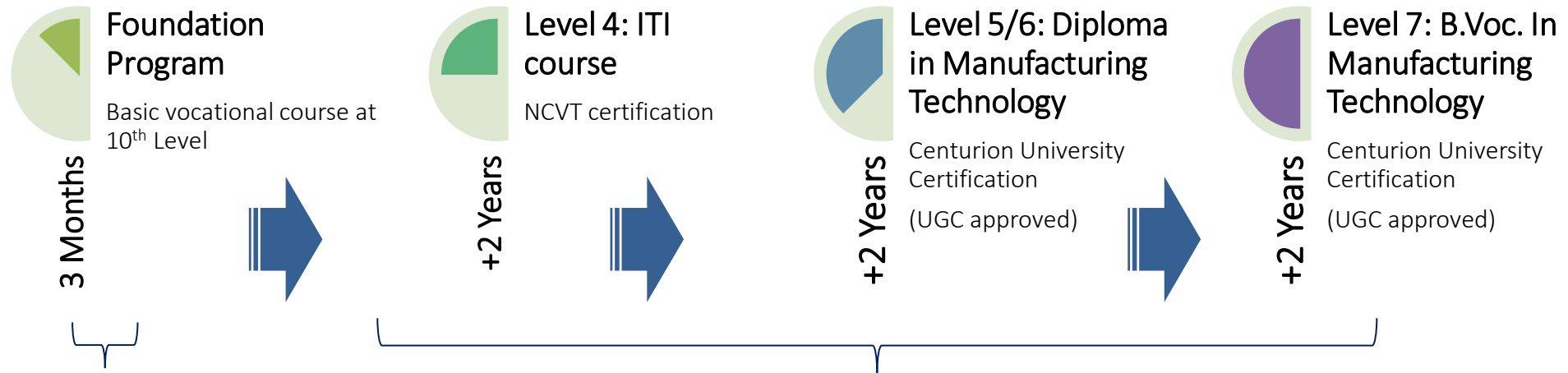

- **10th Pass youth** mobilized from rural areas **Foundation Course** as per curriculum followed by on the job training opportunity with industry partner
- Alternate pathway for 10th Fail through NIOS

- **NEEM: Work Integrated Learning** through a combination of:
 - Contact Classes @ training room in factory or near the hostel
 - e-learning/self learning through content developed by Gram Tarang
 - Practical- job work in workshop or nearby ITI identified by Gram Tarang
 - Assignments, Presentations
 - On the job training & job appraisal
- **Assessments & Certification conducted by**
 - DGT for ITI level (Level 3 & Level 4)
 - Centurion University for Diploma/Advanced Diploma & B.Voc. as per UGC guidelines under DDU Kaushal Kendra scheme

Can a Xth class dropout become an Engineer or an entrepreneur?

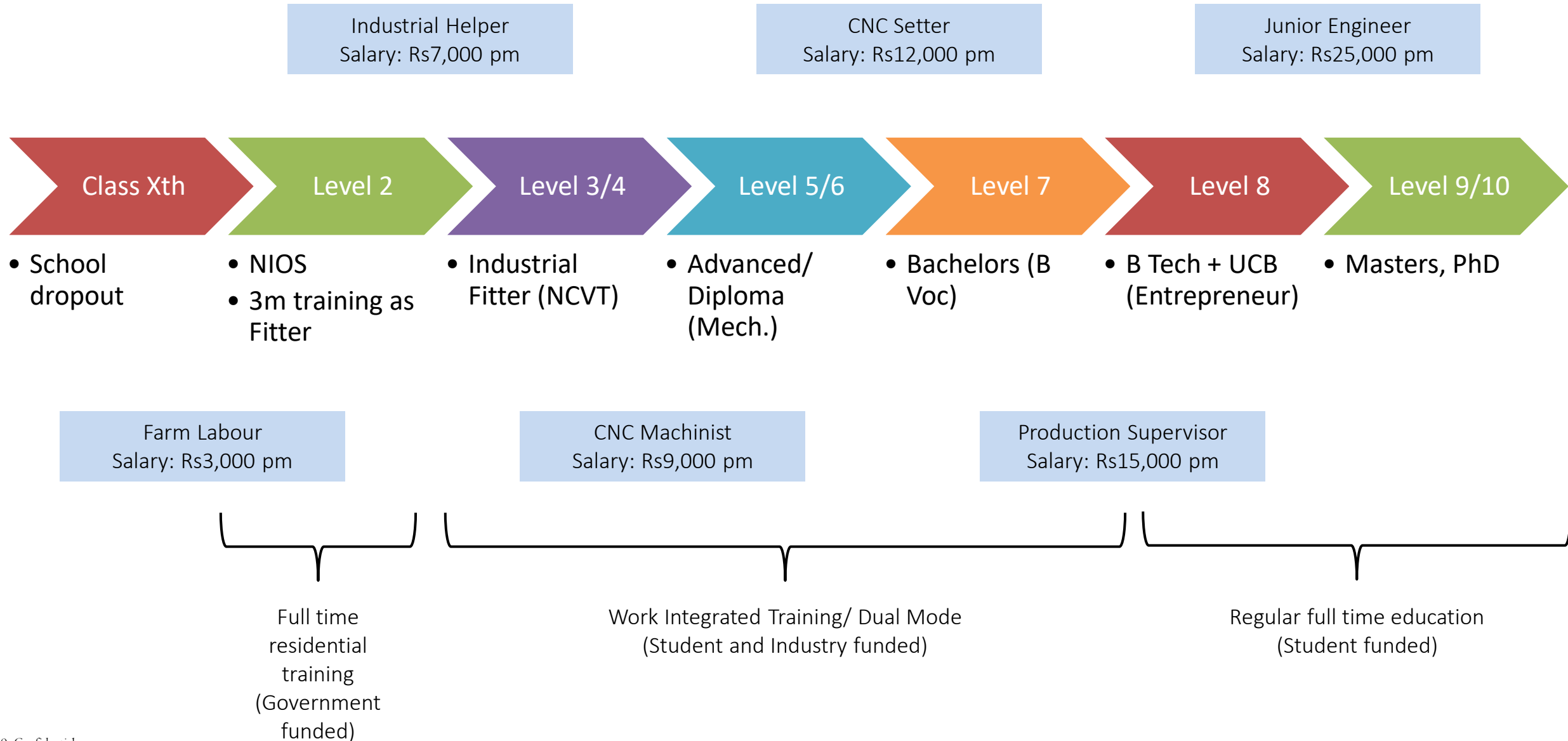

Solution: Dual model of education for upskilling & further education of Blue Collared workforce



Blue collar worker

Career Progression is limited due to lack of skills & qualifications

Technical Education require investment & loss of pay



Grey / white collar worker

Employer



Academia – Industry divide results in low employability of freshers.

Existing skilling schemes are unsustainable & industry is yet to get actively involved at scale

TVET Institutions



Affordable, Accessible & Accredited
Technical qualifications through a blended model enabled its technology platform

Our **product portfolio** spans the entire spectrum, from **short term trainings to industry integrated models**

Further Education and Skilling >>



- Short term skill courses domain and soft skills
- NSQF aligned courses provided in partnership with a University or Awarding Body
- Online Support for ITI & Diploma Colleges

Workforce Training >>



- Focused on imparting shopfloor training of factory workers or entry level blue collar
- Environment health & Safety training, quality orientation for enhanced productivity

Workforce Solutions



- Apprenticeship & Staffing solutions to our Industry Partners



Lernern Navigator with Gooru

Gooru is a Silicon Valley based educational nonprofit that has pioneered a unique **Navigated Learning System** which is an integrated learning exchange that enables all stakeholders in the ecosystem to interact and accelerate learning outcomes. The Navigator functions like a GPS for student learning. It locates each learner's current knowledge and skills and then designs a personalized route to their destination.

Gooru Navigator tools are based on a strong foundation in the learning sciences, artificial intelligence, and education practice, and enables the participants to collaborate and accelerate outcomes for their learners. Navigator is currently in use with more than seven million learners in a variety of settings globally.

Together, **Lernern & Gooru** provide customized technology enabled blended learning solutions for blue collar and shopfloor workers specific to the industry requirements and offer upskilling & further education opportunities to the youth to help shape their futures.



Gooru-Lernern
Navigator,
a GPS for
learning

About the navigated learning system



Learners



Instructors

A cloud based secure platform with mobile app access for learners, instructors, leadership & training content developer for training & development of the workforce.

Leadership



Curriculum Developers

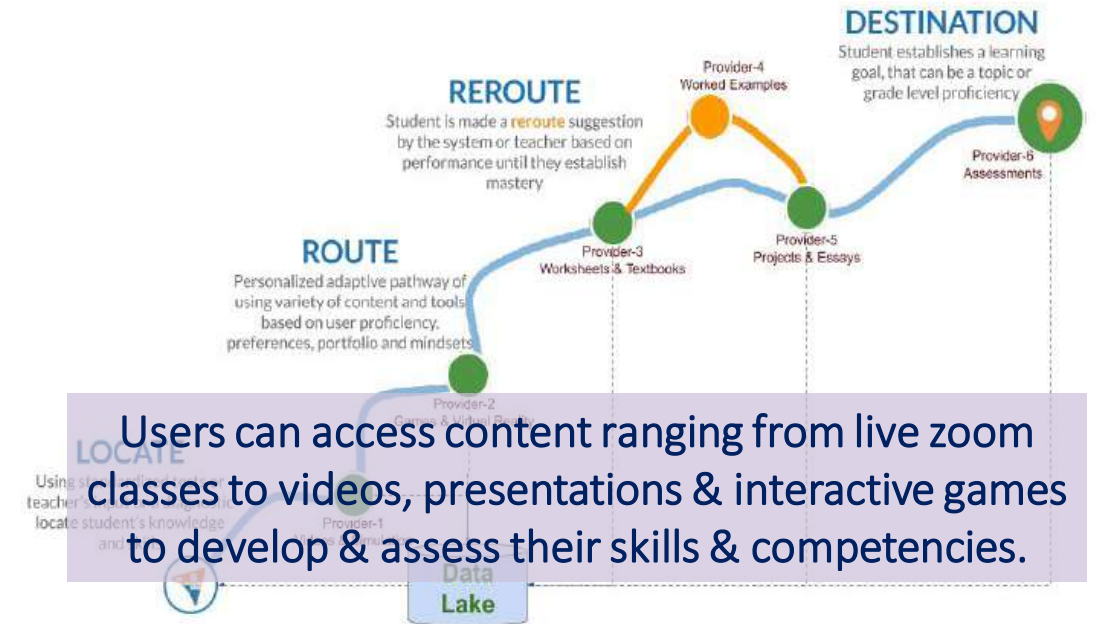

Users can access content ranging from live zoom classes to videos, presentations & interactive games to develop & assess their skills & competencies.



Mission control & performance tracking



Consolidated data from across data streams on one dashboard to create actionable inputs for the management and ability to see factory wise, department wise worker competency

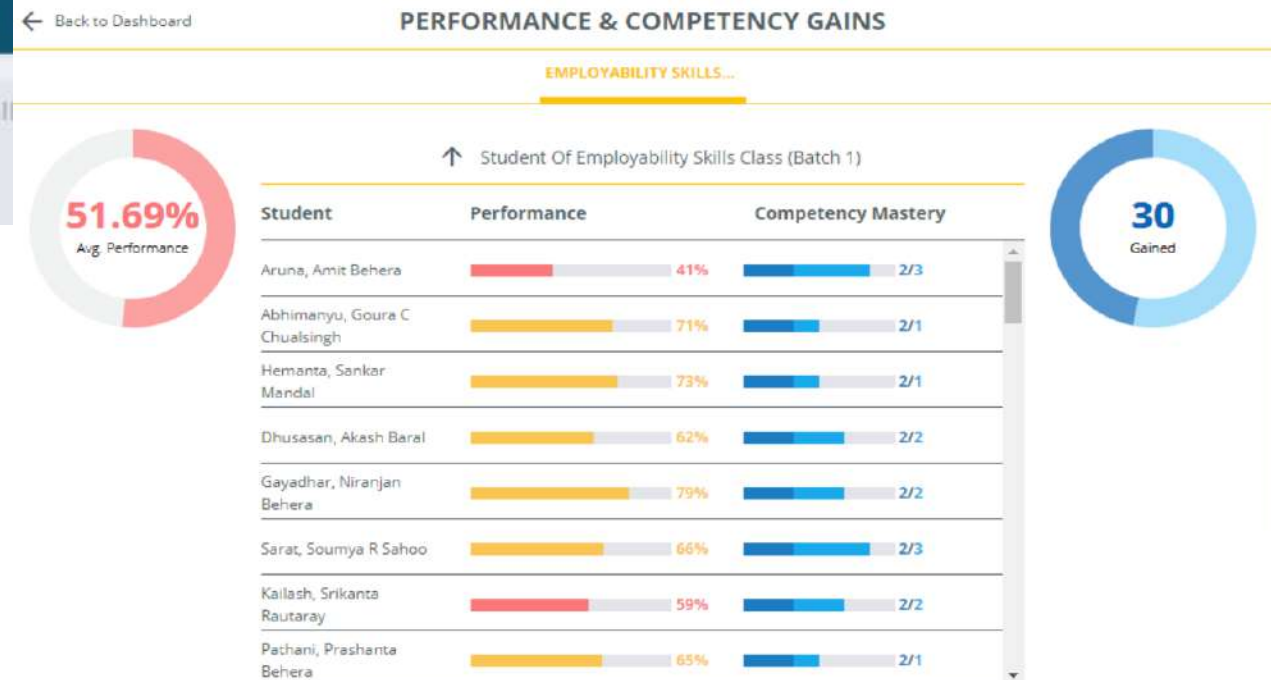

All stakeholders obtain evidence of learning to optimize and coordinate the organizations collective effort to achieve the targeted output

LEARNER journey and skill locator

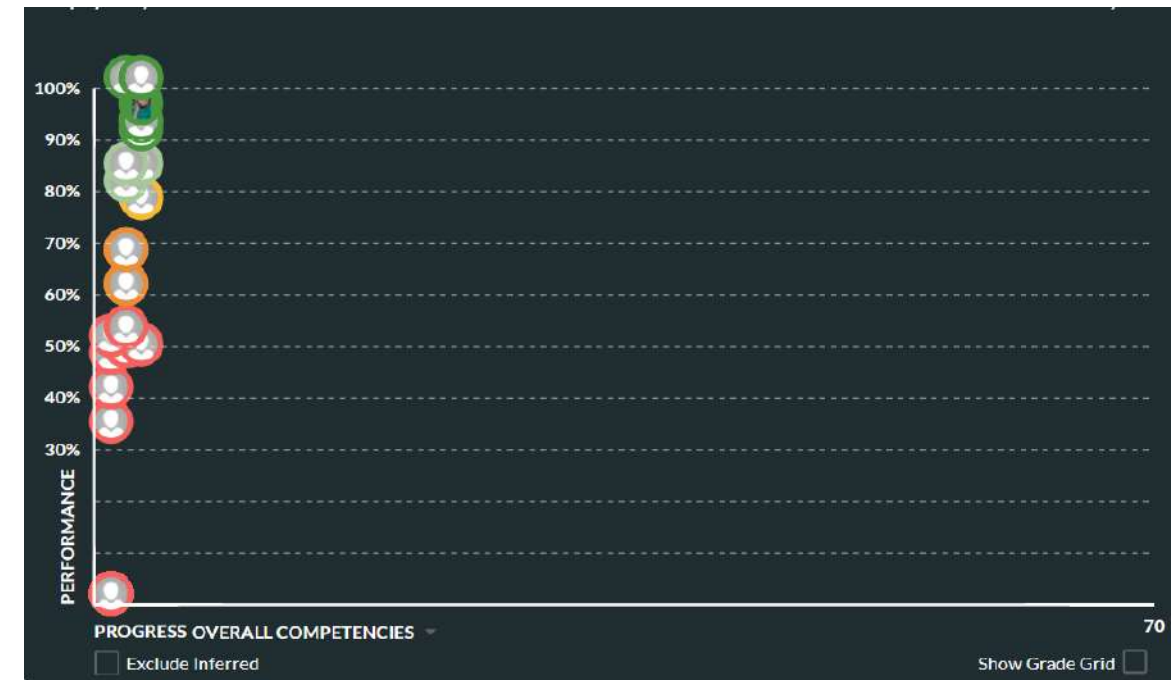
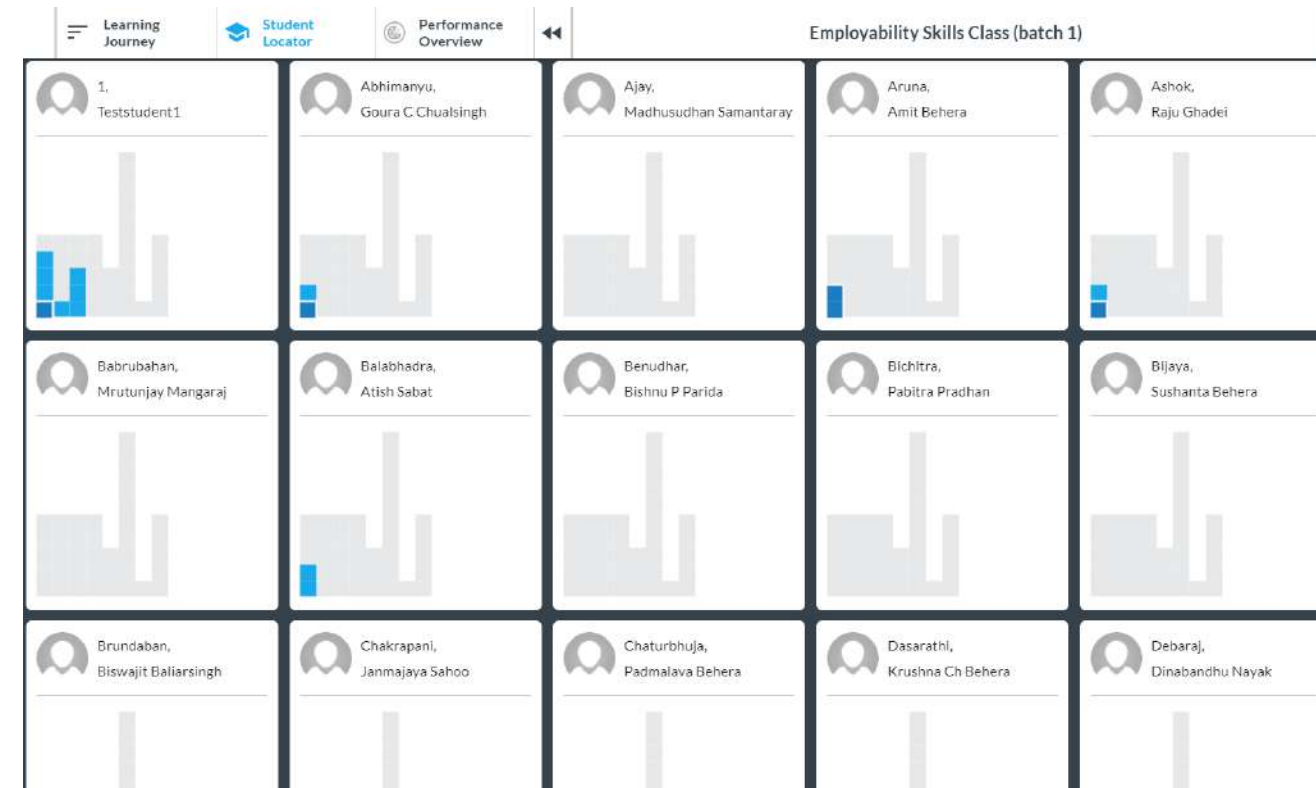

Review employee competency data | Identify individuals progress | Opportunity to engage and provide suggestions

Track learning and development real time

- LOCATE the LEARNERS in REAL-TIME
- Locate the learners wrt current knowledge and mindsets using Navigator with all current practices, curriculum, tools and content
- Use millions of standards aligned open resources to fill the gaps in their learning
- Enable instructor and leadership to personalize intervention to achieve systemic change

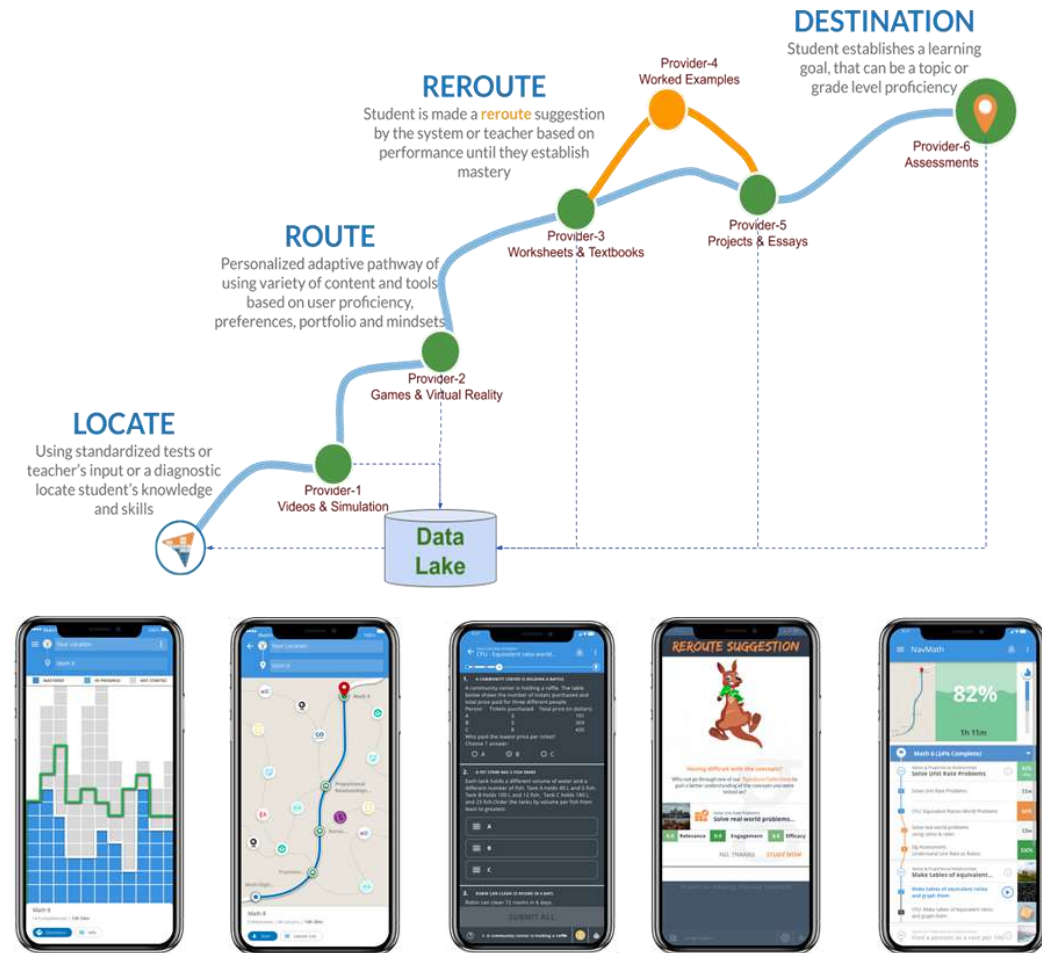

Course map

The screenshot displays the 'CREATE A CLASSROOM' interface with six classroom cards. Each card includes a title, an illustration of two people with a lightbulb, the assigned course name, and a progress indicator. The cards are:

- 2nd year class(2019-2021)**: Assigned Course Electrician, Class Code 9TDTQ60, Progress 0/5880
- Electrician 1st year clas...**: Assigned Course Electrician, Class Code 9RO8BRF, Progress 0/3240
- Electrician Class (batch ...**: Assigned Course Electrician, Class Code ZDI2P7U, Progress 0/7614
- Employability skills (ele...**: Assigned Course Employability Skills, Class Code K7SX48Z, Progress 0/300
- Employability skills (fit...**: Assigned Course Employability Skills, Class Code 7ZSTJQ3, Progress 0/300
- Employability Skills Clas**: Progress 0/300

Gooru enables implementation of agile, systematic changes to the emerging needs.

The screenshot shows the 'Employability Skills Class (batch ...' interface. At the top, it displays 'Learning Journey 56%' and 'Student Locator'. Below this is a 'STUDENTS' list and a 'SHOW COURSE MAP' button. The course map shows a list of topics with their respective progress percentages and student counts:

Topic	Progress	Students
Employability Skills - Semester 1	56%	6
English Literacy Knows how to pronounce	61%	3
English Literacy Knows Functional Grammar	50%	3
English Literacy Improve your Reading	--	--
English Literacy Improve your Writing	--	--
English Literacy Improve Spoken English	20%	1
IT Literacy Understand basics of Computer	--	--
IT Literacy Know & understand about Operating System	--	--
IT Literacy Work on Word Processing and Worksheet	--	--
IT Literacy Basic knowledge of Computer Networking & Internet	--	--
Communications Know about Basics of Communication SKills	--	--

The platform accurately locates the learners across Facets, including their knowledge in various topics

Student journey and skill locator

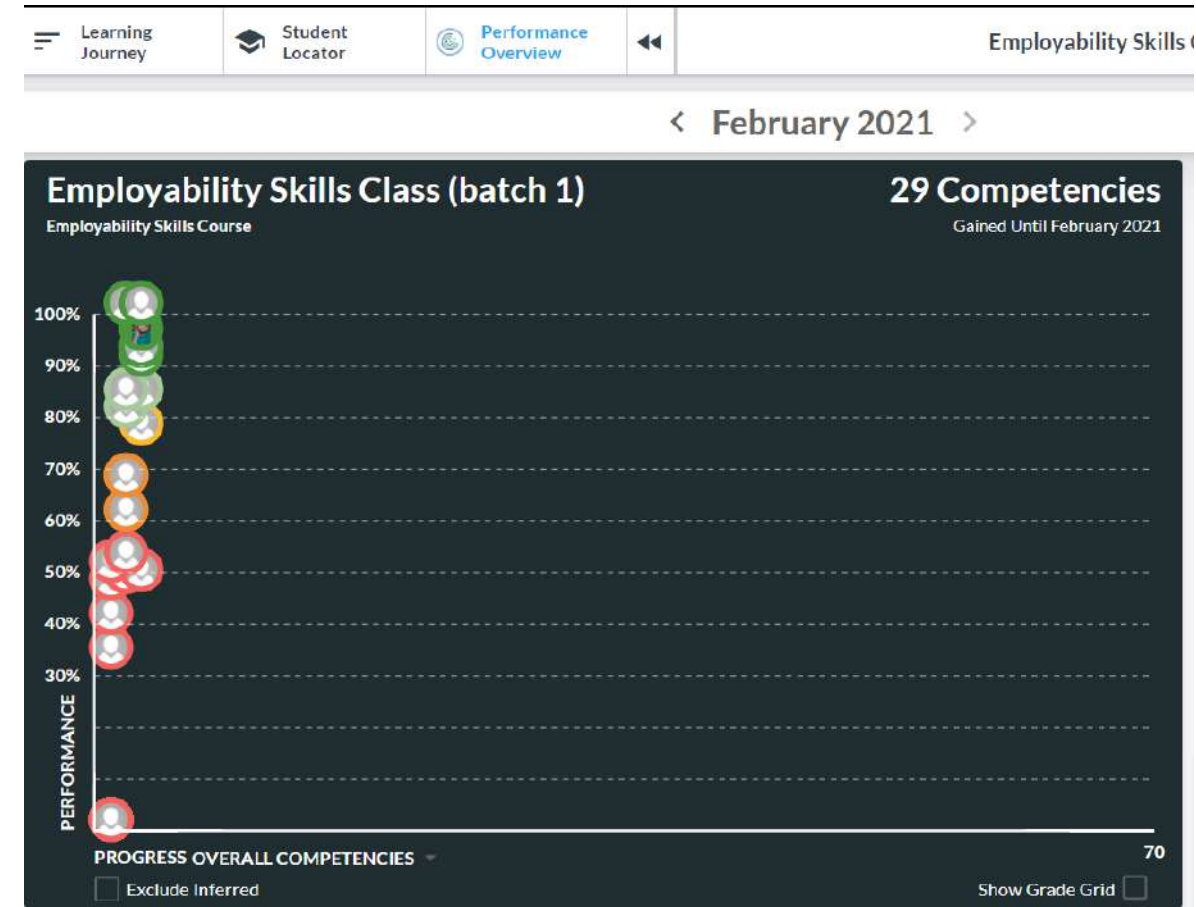
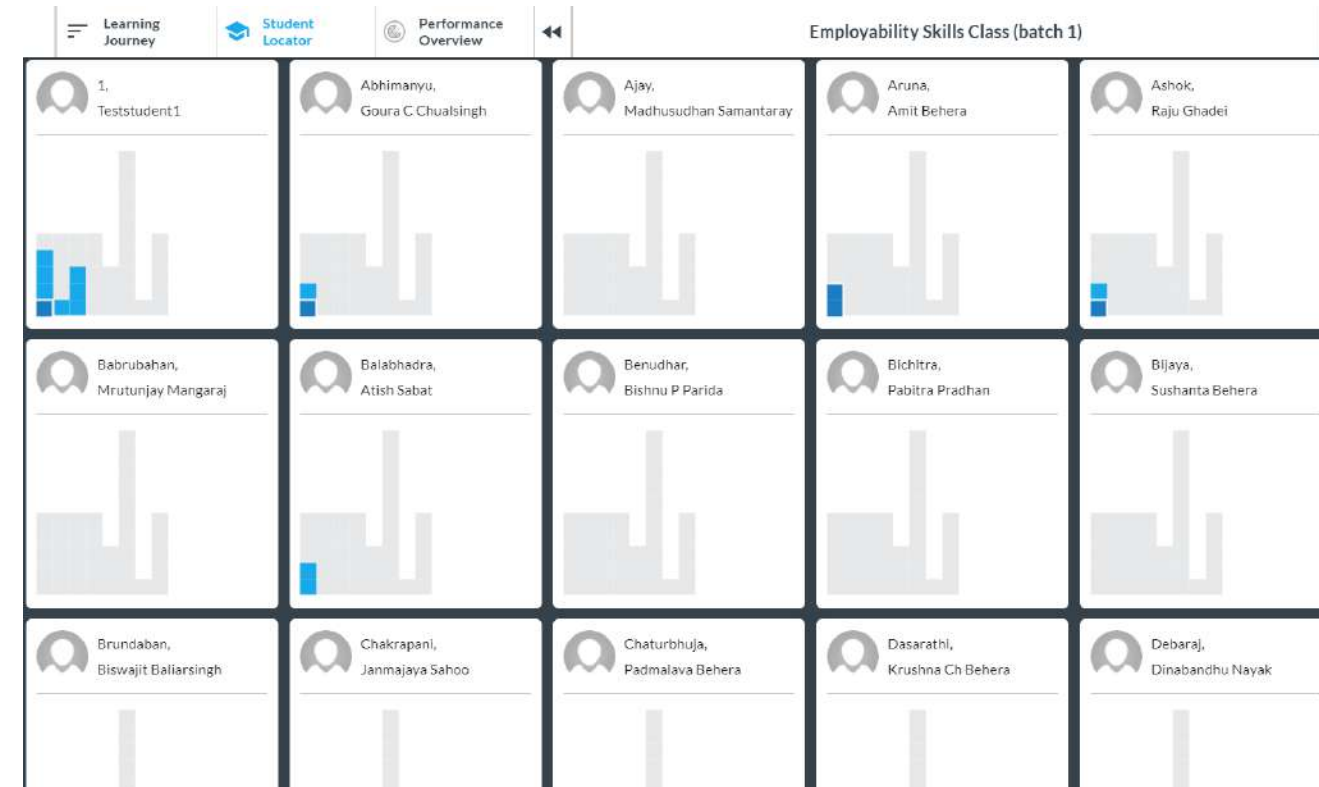

Review employee competency data | Identify individuals progress | Opportunity to engage and provide suggestions

EMPLOYABILITY SKILLS ...

↑ Student Of Employability Skills Class (Batch 1)



Student	Performance	Competency Mastery
Aruna, Amit Behera	41%	2/3
Abhimanyu, Goura C Chualsingh	71%	2/1
Hemanta, Sankar Mandal	73%	2/1
Dhusasan, Akash Baral	62%	2/2
Gayadhar, Niranjan Behera	79%	2/2
Sarat, Soumya R Sahoo	66%	2/3
Kailash, Srikanta Rautaray	59%	2/2
Pachani, Prashanta Behera	65%	2/1

Consolidated data from across data streams on one dashboard to create actionable inputs for the management

All stakeholders obtain evidence of learning to optimize and coordinate the organizations collective effort to achieve the targeted output



WISTA @ KG Mills Coimbatore

- **10th Pass youth** mobilized from rural areas of Odisha, Jharkhand
- **Foundation Course** as per curriculum followed by on the job training opportunity KG Mills in Coimbatore (Accommodation provided on site)
- Alternate pathway for 10th Fail through NIOS
- 10th pass youth enrolled for work integrated ITI where they are given one day of the week to attend full day class & lab practice for pursuing an NCVT certification for Fitter or Electrician
- After initial success, the model is being replicated across more factories in the region.



WISTA @ KG Mills Coimbatore



GTET Trainees @ Western Refrigeration



Work Integrated BBA students



A student of Batch 14 from Bokaro, Jharkhand.

Currently working as a Manager in Café Coffee Day, Bangalore.

Studying in 3rd year of WI BBA(RH).



A student of Batch 14 from Bokaro, Jharkhand.

Currently working as a Manager in Café Coffee Day, Bangalore.

Studying in 3rd year of WI BBA(RH).



A student of Batch 17 from Sonitpur, Assam.

Currently working as a In-charge in Coffee Day Lounge, Bangalore.

Studying in 3rd year of WI BBA(RH).



5

Impact

Acknowledgements,
Appreciation & Accolades



ENDORSEMENT OF THE CENTURION WAY OF EDUCATION

*“Not every university in this region would want to compare themselves to Stanford & Harvard and that they do different functions. so i think that times higher education is committed to trying to get different methods & different metrics to reflect different missions and different priorities. so if your mission like **Centurion University** is really focused on transforming individual lives and giving people the skills that they need to enter employment, basic educational needs, we should recognize that and try and find metrics to celebrate that”*

- PHIL BATY , EDITORIAL DIRECTOR, TIMES HIGHER EDUACATION AT THE GLOBAL SUMMIT ON UNIVERSITY RANKING AT MOROCCO IN MAY 2018

Phil Baty at the Global Summit on Ranking titled 'Empowering the Next Generation of Universities'
May 2018





- From Bokaro, Jharkhand
- Completed her Brewmaster training at Gram Tarang in 2015
- **She is the first girl to move out of her village, her state, live in another state to pursue her career and also to go out of the country and win an award. She is just 20 years old and the eldest daughter of her family.**
- At the 'All Stars Female Barista Competition in Puebla, Mexico' Poonam was in a team of 4 Baristas from Peru, Brazil and Mexico. Her team was recognized as the best performing team at All-Stars, Puebla, 2017

Trainee enrolments over the years

Enrolments across key verticals	2006-07	2007-08	2008-09	2009-10	2010-11	2011-12	2012-13	2013-14	2014-15	2015-16	2016-17	2017-18	2018-19	2019-20	Placement Offers %	LTD
Long Term TVET																
1 NCVT ITI (Fitter, Elec, Welder, Mechanic)	120	182	180	204	300	320	397	419	407	518	499	349	341	403	85%	4,639
2 Diploma Engineering (Mech, Civil, Elec, Auto)	-	-	-	-	-	-	-	-	441	663	575	405	364	422	80%	2,870
Short Term Skilling																
1 Manufacturing Sector	119	157	321	282	1,440	2,768	3,124	2,944	3,103	5,384	4,836	4,025	4,924	5,033	72%	38,460
2 Automotive	24	30	64	70	360	480	702	736	776	1,140	1,486	1,983	2,200	11,500	n/a	21,551
3 Industrial Sewing Machine Operator	-	-	124	970	1,200	2,339	3,266	3,005	3,782	4,412	4,153	5,989	6,615	6,802	95%	42,657
4 Hospitality, Retail, IT/ITeS	-	98	666	1,338	535	827	772	1,433	1,598	1,406	1,358	2,855	3,738	4,426	78%	21,050
5 BFSI	-	-	-	-	763	1,600	1,414	788	3,438	2,872	-	2,563	-	-	100%	13,438
6 Agriculture	-	-	-	-	-	-	-	-	-	-	-	1,198	329	36,835	100%	38,362
In Situ Learning																
NSQF Schools	-	-	-	-	-	-	-	815	2,229	3,460	15,570	23,445	32,287	32,301	n/a	1,10,107
WISTA	-	-	-	-	-	-	-	-	-	-	551	1,130	2,310	5,574	100%	9,565
Grand Total	263	587	1,508	3,037	5,077	8,873	10,179	10,499	16,034	20,189	29,028	43,942	53,108	1,03,296	80%	3,02,699

* For Eligible students

ENROLMENT BY SECTOR

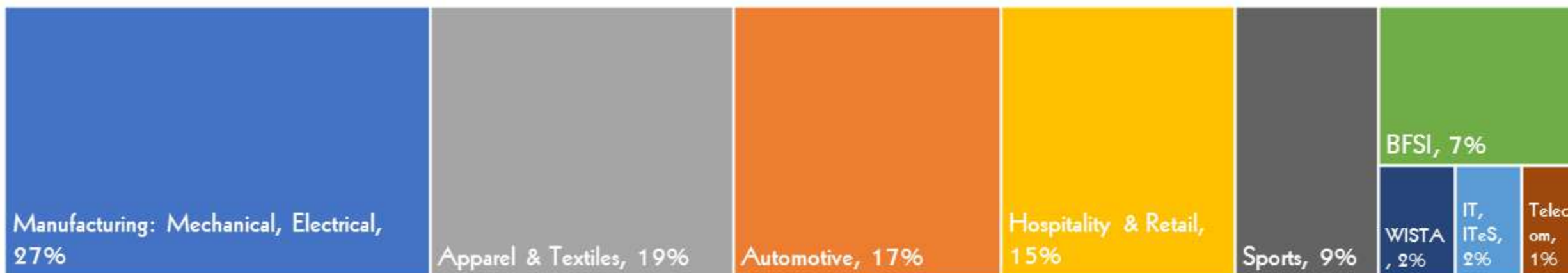

NSDC's highly rated & awarded training partner:

Meeting commitments Year on Year with 100% repayment track record

Revenue: Plan v Actuals

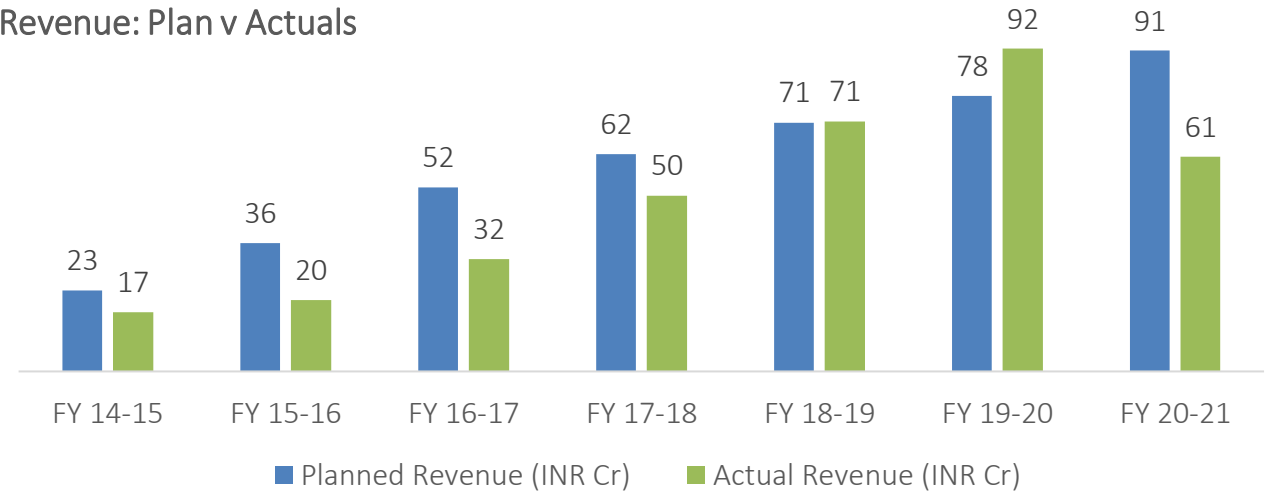

Trained: Plan v Actuals

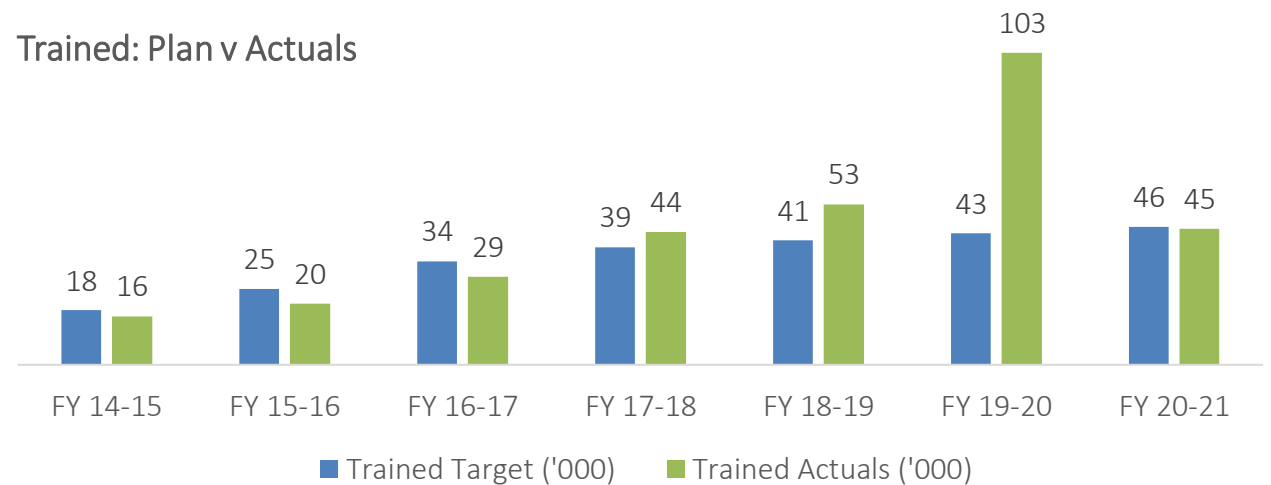

Key awards & recognition

- Third partner of **National Skill Development Corporation** with following awards:

1. Overall Best Performer NSDC Jun, 2012
2. Best Performing Center 2016
3. Best Training Partner NSDC Apr, 2018
4. Best Placement NSDC Apr, 2018
5. Transforming Rural India, NSDC, 2018

- **FICCI Global Skills Summit:**

- Awarded **Best Skills Project** in Rural Community by FICCI & UK-India Business council in 2010 , “Honour Roll - Skills Champion: Emerging Warrior” at Global skills summit in FY 11-12, “Skills Champion of India Award” & at FICCI Global Skills Summit in FY 12-13

- Prime Minister’s sub-group of Chief Ministers on skill development hosted by NITI AYOJ prominently described Gram Tarang CUTM and its model of **integrating skill with higher education**, ensuring appropriateness and relevance of education.

- Only University invited by the **Prime Minister** to address the Nation on World Youth Skills Day – 15th July 2015. National Skill Mission commissioned & launched by the Prime Minister.

- Two ITIs operated and managed by Gram Tarang has been ranked among the **Top Ten in the MSDE ITIs Ranking 2018**



- **UN General Assembly:** Cited as a best practice in UN report on right to education
- **NITI AYOOG (2016):** Centurion University – Gram Tarang as the best practice, the only example from Odisha, in the Report “State Forward – Best Practices From Our States”
- **Parliamentary committee on skill development:** Recognition of Skill integrated higher education by the delegation of 25 Members of Parliament (MP) headed by the Hon’ble Minister (2nd visit) for Skill Development & Entrepreneurship and Parliamentary Affairs, Shri Rajiv Pratap Rudy (28th January 2016)

Prime Minister’s sub-group of Chief Ministers on skill development hosted by NITI AYOOG prominently described CUTM and its model of **integrating skill with higher education**, ensuring appropriateness and relevance of education.

Special mention by **World Bank, UNESCO, McKinsey & Economist** in various reports

Centurion University’s model of livelihood focus in higher education documented as a best practice and case study by E&Y

United Nations

A/67/310



General Assembly

Distr.: General
15 August 2012

Original: English

Sixty-seventh session

Item 70 (b) of the provisional agenda*

Promotion and protection of human rights: human rights questions, including alternative approaches for improving the effective enjoyment of human rights and fundamental freedoms

The right to education

Note by the Secretary-General

The Secretary-General has the honour to transmit to the General Assembly, in accordance with Human Rights Council resolution 8/4, the report of the Special Rapporteur on the right to education, Kishore Singh.

Working actively on 5 of 17 UN's Sustainable Development Goals

SUSTAINABLE DEVELOPMENT GOALS

1 NO POVERTY



2 ZERO HUNGER



3 GOOD HEALTH AND WELL-BEING



4 QUALITY EDUCATION



5 GENDER EQUALITY



6 CLEAN WATER AND SANITATION



7 AFFORDABLE AND CLEAN ENERGY

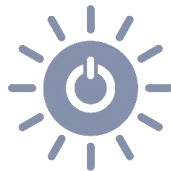

8 DECENT WORK AND ECONOMIC GROWTH



9 INDUSTRY, INNOVATION AND INFRASTRUCTURE



10 REDUCED INEQUALITIES

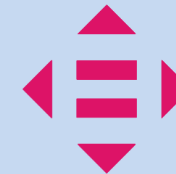

11 SUSTAINABLE CITIES AND COMMUNITIES



12 RESPONSIBLE CONSUMPTION AND PRODUCTION



13 CLIMATE ACTION



14 LIFE BELOW WATER

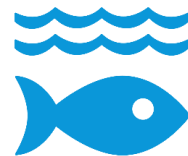

15 LIFE ON LAND



16 PEACE, JUSTICE AND STRONG INSTITUTIONS

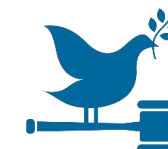

17 PARTNERSHIPS FOR THE GOALS



CENTURION UNIVERSITY

THE WORLD OF HOPES & POSSIBILITIES



Constituent Campuses: Jatni | Paralakhemundi |
Rayagada | Bolangir | Vizianagaram

www.cutm.ac.in | www.gramtarang.org.in



Phone: +91 (0674) 2596228