

INVESTMENT GRADE ENERGY AUDIT REPORT
of Centurion University of Technology & Management
Balangir



Submitted to:

Centurion University of Technology & Management

Behind BSNL Office, IDCO land
Rajib Nagar, Balangir, Odisha- 767001
Tel - 06652-235641/235642/235644
Mobile: 9437037148
E-mail: pradip.sarangi@cutm.ac.in
Website: www.cutm.ac.in



Power Tech



Submitted by:

M/s. Swain & Sons Power Tech Pvt. Ltd.

Corporate Office: K-8-82, Kalinga Nagar, Ghatikia
Bhubaneswar-751029, Odisha

Phone: 0674-2954256, Mob: 9438747172, 8093533005, 9937159760

Email: sspt12@gmail.com, info@pwrtech.com

Website: www.pwrtech.com

Table of Contents

ACKNOWLEDGEMENT	5
AUDIT TEAM DETAILS	6
CERTIFICATE	7
EXECUTIVE SUMMARY	8
1.0 INTRODUCTION.....	10
1.1. About the Site.....	11
1.2. Scope of Work	11
1.3. Methodology.....	13
Instruments Used	14
2.0 BRIEF DESCRIPTION OF THE UNIVERSITY	14
2.1 Major Utilities.....	15
3.0 ENERGY SCENARIO	16
3.1 Analysis of Energy Bill.....	17
3.2 Base Line Energy Consumption and Specific Energy Consumption.....	20
3.3 Electrical Distribution System and Water Distribution System	24
3.4 Transformer Details	26
3.5 Study of Voltage, Current, Power Factor Profile	27
4.0 LIGHTING SYSTEM	32
4.1 Lighting Inventory	32
4.2 ENCON option for lighting system.....	34
4.3 O & M Practice, Energy Accounting and Monitoring For Lighting System.....	35
4.4 Illumination Survey and LUX Level Measurement	36
4.5 ENCON Option for Installation of Solar Water Heater.....	37
4.6 ENCON Option for Installation of Solar Power Plant in Net Metering Concept.....	37
5.0 HVAC System.....	40
5.1. ENCON Option for Installation of AC Saver for old 1.5 Ton AC.....	40
5.2 Advantages of Inverter Air Conditioner	43
5.3 Maintenance Tips for Split / Window AC	44
6.0 Fan Inventory.....	45
7.0 DIESEL GENERATING (DG) SET	46
7.1 Observation & Analysis for DG Set	46
7.2 Recommendation.....	47
8.0 TRANSPORTATION	47
9.0 WATER PUMPING SYSTEMS.....	48
9.1 Water Pumping Storage and Distribution System	48

9.2	Utilization of water Pumping System.....	48
9.3	Rain Water Harvesting System	48
9.4	Sewage Treatment Plant	49
9.5	Operation and Maintenance of CUTM	49
9.6	Energy Monitoring & Accounting System.....	49
10.0	TECHNICAL SPECIFICATIONS FOR ENERGY EFFICIENT PRODUCT	51
11.0	MOU Format with EESL.....	55
12.0	ENERGY MANAGEMENT POLICY	58
Annexure:	60
13.0	Vender Details of Projects	63

LIST OF ABBREVIATIONS

AC	: Air Conditioning
BEE	: Bureau of Energy Efficiency
LED	: Light Emitting Diode
CTR	: CT Ratio
DB	: Distribution Board
DG	: Diesel Generator
ENCON	: Energy Conservation
Hrs	: Hours
HT	: High Tension
I	: Current
V	: Voltage
kL	: Kilo Liter
kV	: Kilo Volt
KVA	: Kilo Volt Ampere
kVAh	: Kilo Volt Ampere Hour
kVAR	: Kilo Volt Ampere Reactive
kW	: Kilo Watt
kWh	: Kilo Watt Hour
THD	: Total harmonic distortion
LT	: Low Tension
PF	: Power Factor
PTR	: PT Ratio
SEC	: Specific Energy Consumption
TF	: Transformer
UF	: Utilization Factor

ACKNOWLEDGEMENT

Swain & Sons Power Tech Pvt. Ltd. (SSPTPL) places on record its sincere thanks to Centurion University of Technology & Management for entrusting the task of conducting the Investment Grade Energy Audit of Centurion University of Technology & Management (CUTM), Balangir.

SSPTPL acknowledges with gratitude the wholehearted support and encouragement given by all CUTM officials while carrying out the energy efficiency study at CUTM.

SSPTPL acknowledges with gratitude and sincerely thanks all the officials and staff members of Centurion University of Technology & Management who have rendered their all-possible co-operation and assistance to the study team during the entire period of the Audit.

Our special thanks to Mr. Pradeep Ku Sarangi (Regional Director), Mr. Somanath Sarangi (Principal, SOAs), Mr. Bibhu M.P. Tripathy (Office Superintendent) and the Energy Conservation Cell Members for their whole hearted co-operation and guidance in carrying out the Investment Grade Energy Audit of CUTM, Balangir.

Signature



Subhranshu Sekhar Rath
General Manager

Swain & Sons Power Tech Pvt. Ltd.

Empanelled ESCO by BEE, Ministry of Power- CRISIL SME GRADING:CRISIL-BEE Grade 3
K-8-82, Kalinga Nagar, Ghatikia, Bhubaneswar-751029, Odisha

Phone: 0674-2954256

Mobile: 8093533005, 9438747172

Email: sspt12@gmail.com, info@pwrtch.com

Website: www.pwrtch.com

AUDIT TEAM DETAILS

1. Mr. Subhranshu Sekhar Rath, General Manager
2. Mr. Nilamani Behera, Sr. Consultant, Energy Auditor Regd. No. -EA-9407
3. Mr. Suresh Gurjar, Manager
4. Mr. Nirjhar Biswal, Assistant Manager (Project)
5. Mr. Suraj Kumar Bhujabala, Assistant Manager (Project)
6. Mr. Subash Mallick, Project Associate
7. Ms. Lalita Kumari Swain, Project Associate

We express our sincere thanks to the following students of CUTM, Bhubaneswar for showing their interest and involvement in conducting the energy audit of CUTM, Balangir campus.

Sl.	Name	Enrolment No
1	Ms. Riya Saha	200301150006
2	Mr. Rohit Mishra	200301150002
3	Mr. Siddharth Singh	200301150003
4	Mr. Azharhul Haque	200301151016
5	Mr. Pradeepta Kumar Mohanta	200301150012
6	Mr. Chandrasekhar Maharana	200301151017
7	Mr. Anirban Hatui	200301150011
8	Mr. Papu Jagganath Rao	200301150007
9	Mr. B. Sai	200301151015

CERTIFICATE

We certify the following

- The data collection has been carried out diligently and truthfully.
- All data measuring devices used by the auditor are in good working condition, have been calibrated and have valid certificate from the authorized approved agencies and tampering of such devices has not occurred.
- All reasonable professional skill, care and diligence had been taken in preparing the energy audit report and the contents thereof are a true representation of the facts.
- The investment grade energy audit has been carried out in accordance with the BEE prescribed norms.

Signature



Subhranshu Sekhar Rath
General Manager

Swain & Sons Power Tech Pvt. Ltd.

**Empanelled ESCO by BEE, Ministry of Power- CRISIL SME GRADING:CRISIL-BEE Grade 3
K-8-82, Kalinga Nagar, Ghatikia, Bhubaneswar-751029, Odisha**

Phone: 0674-2954256

Mobile: 8093533005, 9438747172

Email: sspt12@gmail.com, info@pwrtch.com

Website: www.pwrtch.com

EXECUTIVE SUMMARY

The journey of Centurion University of Technology and Management (CUTM) began in the year 2005 by a group of ambitious academics with aspirations to provide high quality education both nationally and internationally. The first step in this direction was to take over an ailing engineering Institute, the Jagannath Institute for Technology and Management (JITM) in one of the most challenging tribal districts of Odisha and one which was considered to be a left-wing extremist affected area. Subsequently, JITM was transformed into Centurion University of Technology and Management (CUTM) in August 2010, through an act of Odisha Legislative Assembly. It became the First Multi-Sector State Private University in Odisha. The campus is spread over 15 acres. The complex includes School of Applied Sciences and School Of Pharmacy. The CUTM Balangir Campus is located in the heart of the Balangir City which is well connected by rails and roadways.

Goals and Objectives of the Energy Management Programme:

The Investment Grade Energy Audit of Centurion University of Technology & Management, Balangir was carried out during the period of July 2022. Energy Conservation is a major focus and requirement in Institutional, Commercial and Government Buildings, and hence the management of Centurion University of Technology & Management, has entrusted the work of conducting Investment Grade Energy Audit (IGEA) of their entire campus to Swain & Sons Power Tech Pvt. Ltd. The main focus of the audit was to establish Specific Energy Consumption for all the Buildings & Vehicles for last financial year 2021-22, collection of technical information like specification of the machines, details of all the buildings, fuel consumption in all the DG, water consumption details, etc.

Centurion University of Technology & Management, Balangir is availing power supply from TPWODL, local DISCOM Connections at 11 kV Voltage level and through a 100 KVA power transformer with contract demand of 35 kW (Consumer no. 911001030356).

SUMMARY OF THE ENERGY BILLS FOR THE LAST FINANCIAL YEAR OF CUTM BALANGIR							
Year	Description	Electricity consumed in kWh	Avg. MD in kVA	Power Factor	Load Factor	Energy Bill in Rs.	Energy Charge in Rs./kWh
For Financial year 2021-22	Monthly average	8571	50	0.99	2.92	68858	7.6
	Daily Average	286	50	0.99	2.92	2295	7.6

The major utilities of Centurion University of Technology & Management, Balangir are Electricity, Water and HSD. The electricity is utilized for Lighting, Fans, Pumping of water, Computer, Printer, Laboratory, Water cooler, Fridge, Projector, Speaker and AC. HSD is utilized in DG set and Transportation Vehicles. Water consumption is there in all the buildings for day-to-day domestic purposes and also for plantation, gardening and cleaning.

During the study, various energy conservation options were identified, their cost benefit analysis was found out and same is furnished below. It is recommended that CUTM may implement the Energy Conservation Option as suggested in the report.

Details of Energy Conservation measures / Recommendations of Accredited Energy Auditor for Improving Energy Efficiency						
[See rule 3(1) (c)]						
Energy Saving measures	Anticipated Investment (In Lakh)	Anticipated Annual Savings (In Lakh)	Simple Pay Back Period in Year	Anticipated Annual Energy Savings		
				Electricity in kWh	Thermal Energy in kcal	Equivalent Energy in TOE
Installation of Roof top Solar Power Plant	30	5.99	5.0	99864		9
Replacing Conventional Ceiling Fan with 75 W Super Energy Efficient Ceiling Fan	11.27	3.28	3.4	54606		4.7
Replacement of 36W FL Tube Fittings with 20 W LED Tube	1.77	1.7	1.1	28051		2
Installation of Solar Water Heater at CUTM Canteen	0.7	0.6	1.2		7247899	1
Installation Lightpipe Fitting System	1	0.49	2	8448		0.73
Installation of AC Saver for Old 1.5 Ton AC	2	1.4	1.4	23693		2.04
Installation of Light Motion Sensor at Boys Canteen to reduce lighting load	0.042	0.020	2	345		0.030
Total	47	13	3.48	215006	7247899	19

1.0 INTRODUCTION

The Government of India has enacted the Energy Conservation Act, 2001 with the objective of providing sustainable and more efficient management of our energy resources. The aim of Energy Conservation (EC) Act 2001 is to provide the much-needed legal framework and other institutional arrangements so that various energy efficiency improvement drives can be easily launched at the state and national level. In order to implement the various provisions under the EC Act 2001, the Government of India has established the Bureau of Energy Efficiency (BEE), to enact and enforce energy efficiency through various regulatory and promotional measures.

Energy Conservation has become a top most priority in today's scenario in order to have a sustainable growth, productivity, enhancement and Environmental Protection. Considering the vast potential of energy savings and benefits of energy efficiency as per the report prepared by National Development Council (NDC) Committee on power, Govt. of India enacted the Energy Conservation Act 2001. Accordingly, the Govt. of India set up the Bureau of Energy Efficiency (BEE) under the provision of the Energy Conservation Act 2001 for development of policies and strategies with a thrust on self-regulation and market principles, with the primary objective of reducing energy intensity of the Indian Economy.

Buildings consume significant portion of Energy for lighting, Air Conditioning, Ventilation purpose and hence Energy Conservation is a major focus and requirement in Institutional, Commercial and Government Buildings. Besides Building owners are also focusing Energy Conservation and Energy Efficiency in large extent for a higher productivity. Efficient Energy management, Usage of Energy Efficient Technologies and adopting best-practices that would help a Building Owner to reduce their energy cost considerably. Hence in order to identify the energy conservation opportunities and reduce the present energy consumption, the management of CUTM has entrusted the work of conducting Investment Grade Energy Audit (IGEA) to Swain & Sons Power Tech Pvt. Ltd. The Energy Audit of CUTM was carried out in the period of July 2022. The scope of work includes collection of existing layout of Building, Collection of various data including lighting inventory, AC list, Pump, Motor and other electrical load list, Collection of Month wise Energy Bill for FY 2021-22, Power measurement of all running Transformer, Panels, AC, Pump and Motor and submission of Energy Audit Report along with details of Energy Conservation Opportunity.

1.1. About the Site

Situated in the western region of Odisha, the campus is spread over 15 acres of land. The CUTM Balangir Campus is located in the heart of the Balangir City which is well connected by rails and roadways. The journey of Centurion University of Technology and Management (CUTM) started with the takeover of Jagannath Institute for Technology and Management (CUTM) in 2005. Subsequently, CUTM was transformed into Centurion University of Technology and Management in August 2010, through an act of Odisha Legislative Assembly. The complex includes School of Applied Sciences and School of Pharmacy.

1.2. Scope of Work

a) Review of present electricity consumption and fuel oil. Estimation of energy consumption in various loads like lighting, HVAC, DG Set etc in premises of the Building.

b) **Electrical Distribution system:**

- Review of present electrical distribution from the single line diagram (SLD). Study of operation/loading of distribution transformers, cable loading, normal and emergency loads, electricity distribution in various area/ floors and loss estimation.
- Study of reactive power management and option for power factor improvement, functioning of capacitor banks.
- Study of power quality, like harmonics, current unbalance, voltage unbalance etc.
- Exploring the energy conservation options (ENCON) in the electrical distribution system.

c) **Lighting System**

- Review of present lighting system, lighting inventories etc.
- Estimation of lighting load at various locations like different floors, outside (campus) light, pump house and other important locations.
- Detailed illuminations survey with measurement of LUX level at various locations and comparison with acceptable standards.
- Study of present lighting control system, lighting maintenance systems, present procedure for management of lighting spares and consumables and recommendation for improvement
- Analysis of lighting performance indices like LUX/m² LUX/Watt, LUX/Watt/m² and comparison of the same with benchmark.
- Exploring the possibility of retrofitting option with energy efficient lighting system like LED lamp, control Gears, sensors and automators, voltage regulators and solar based system.
- Developing a suitable lighting energy accounting and monitoring system.

- Exploring the energy conservation options (ENCON) in lighting system.

d) Heating Ventilation & Air conditioning system (HVAC system)

- Review of present HVAC system like Spilt AC, Window AC, water coolers and air heater etc.
- Performance assessment of window AC, and Split AC.
- Analysis of HVAC performance like estimation of Energy Efficiency Ratio (EER) i.e. (KW/TR) and comparison of the operating data with the design data and recommendation for best prices/standard requirement.
- Exploring the energy conservation options (ENCON) in HVAC system

e) Diesel Generators (DG) sets

- Review of DG set operation.
- Performance Assessment of DG sets in terms of specific fuel consumption (SFC i.e. kWh/Ltr.), Exploring the energy conservation options (ENCON) in lighting system.
- Exploring the energy conservation options (ENCON) in DG sets.

f) Water pumping system

- Review of water pumping, storage and distribution systems.
- Performance assessment of all major water pumps i.e. power consumption vs. flow delivered, estimation of pump efficiency etc and compare with best practices
- Study of the flow control mechanism.
- Study of rational utilization of water pumping system, energy efficient retrofitting etc.

g) Motor Load survey

- Conducted the motor load survey.
- Survey of motor loading (% loading) for major electrical drives.
- Measurement of all electrical parameters like voltage, current, PF & KW for all running motors and calculation of pump efficiency and suggestions for improvement.
- Study of mechanical power transmission system and suggest for energy efficiency.
- Study of rational usage of drives for reducing electrical energy consumption.

h) Energy Monitoring & Accounting System:

- Detail Review of present energy monitoring & accounting system in terms of metering, record keeping, data logging, periodic performance analysis etc.
- Suggest for procedures for improvement in energy monitoring and accounting system.

i) UPS

- Measurement and analysis of the UPS loading, redundancy, operating efficiency, load pattern to suggest measures for energy cost reduction, measurement and analysis of Harmonics.

j) Others:

- Review of present maintenance practice, replacement policies and building safety practices as applicable to high rise buildings and recommend for improvement.
- Cost benefit Analysis of each ENCON indicating simple payback period.

1.3. Methodology

The following step by step methodology and approach were adopted to carry out the Investment Grade Energy Audit Report of CUTM, Balangir. Prior to energy audit, SSPTPL team made a walk through survey of the Building and associated subsystems to assess the followings:-

- The existing layout of Building.
- Collection of various data including lighting inventory, AC list, Fan list, Motor and other electrical load list.
- Collection of Month wise Energy Bill for FY 2021-22.

The methodology was explained / discussed with CUTM, Balangir officials. The broad methodology adopted for the Energy Audit at CUTM is furnished below.

1. The program of visit of energy audit team to site for carrying out the IGEA work was informed to CUTM, Balangir officials.
2. Data collection and Energy Bill Collection was carried out through discussions with the officials and from past records, log books.
3. Technical specification of equipments and their operating parameters were collected, while visiting the area. The data so collected were analyzed and the deviations were noted.
4. Performance of the major energy consuming equipments was analyzed.
5. Measurement of electrical energy parameters, wherever possible, using portable instruments were carried out.
6. Power Measurement of all running Transformer, Panels, AC was carried out using portable power analyzer brought by PTC for this purpose.
7. Review of present lighting system, lighting inventories collection were carried out. Estimate all lighting load at various locations like different parts of Building, outside area i.e. street lighting and area lighting and other important locations. Also detailed illuminations survey was determined with measurement of LUX level at various locations.

8. Ambient parameters (Temperature, Humidity) were measured using portable test instrument brought by SSPTPL.
9. Energy Conservation option were identified and tabulated on the basis of priority.
10. Draft soft copy of energy audit report comprising of observations and recommendations with adequate financial justification, vendor support data, etc. was prepared and submitted to CUTM, Balangir for acceptance.
11. Final energy audit report was submitted after acceptance of the draft energy audit report.

Instruments Used

SSPTPL have a wide array of latest, sophisticated, portable, diagnostic and measuring instruments to conduct energy audit investigations and analysis. The following special portable instruments are used to carry out various field measurements and analysis during the energy audit period.

- Three Phase Power Analyzer(ALM-30)
- Clamp on electrical power analyzers
- Infrared Non-Contact Thermometer
- Thermal Camera
- Anemometer
- Hygrometer
- LUX Meter
- Power Guard

2.0 BRIEF DESCRIPTION OF THE UNIVERSITY

Name & Address

Centurion University of Technology & Management
Behind BSNL Office, IDCO Land, Indira Nagar, Balangir
Dist: Balangir, Odisha-767001
Tel: 9437293374

Name & Details of the Authorized Signatory of CUTM, Balangir

Mr. Pradeep Kumar Sarangi (Regional Director)
Mobile: 9437037148
E-mail: pradip.sarangi@cutm.ac.in

Name & Details of the Project Coordinator

Mr. Somanath Sarangi (Principal, SOAS)
Mobile: 9437890943
E-mail: somnath@cutm.ac.in

DESCRIPTION OF CAMPUS:

Centurion University of Technology & Management (CUTM) is the first multi-sector state private university in Odisha, located behind BSNL Office, IDCO Land, Indira Nagar Balangir, Odisha 767001, spread over 15 acres. It is the only technological University in South Odisha. It is located at latitude 20°41'17"N & longitude 83°28'33"E. Nearest Railway station is Balangir junction.

The complex includes School of Applied Sciences and School of Pharmacy.

University is having approximately 60 numbers of teaching staff members, 1300 numbers of Students, 47 numbers of non-teaching staff including Electrician, Plumber.

Centurion University of Technology & Management, Balangir is availing power supply from TPWODL, local DISCOM Connections at 11 kV Voltage level and through a 100kVA power transformer and with contract demand of 35 kW (Consumer no. 911001030356). One number of DG Set i.e. of capacity 62.5 kVA is present for providing power supply during emergency .



(Google Earth View of CUTM, Balangir)

2.1 Major Utilities

- Electricity
- Water
- HSD

Electricity:

Electricity is utilized for Lighting, Fans, Pumping of water, Computer, Printer, Laboratory, Water cooler, Fridge, Projector, Speaker and AC, etc.

Water:

Water consumption is in all the Buildings for day to day usage and also utilized in plantation, gardening and cleaning.

HSD:

HSD is consumed in DG set and Transportation.

3.0 ENERGY SCENARIO

CUTM receives the electrical power supply from TPWODL at 11kV. The present contract demand of the Building with TPWODL is 35kW. The energy fact file of the building is furnished below:

Table: Energy Fact File of CUTM, Balangir

Location	Jagannath Institute of Technology & Management (CUTM), At: Industrial Growth Centre, Balangir Pin-767001
Areas of Utilization of Energy	JITM (CUTM), Balangir
Source of Supply	11kV Distribution Line from Rajiv Nagar Substation Of TPWODL
Total Contract Demand	35kW
Major Loads	Lighting & Power, Air Conditioning, Heating & Cooling, Computers, Printers, Fans, Pump, Motor, DG Set, Household Appliances and Other loads
Usage Hours	Mainly 09.00 am to 6.00 pm on all working days
Monthly Energy Consumption	8571 Units
Monthly Energy Bill	Rs. 68858

Building Audit Data Sheet		
Sl. No.	Item	Value
Size, Age & Construction of the building		
1	Connected Load (kW) or Contract Demand (KW)	35
2	Installed Capacity: DG Sets (KVA or KW)	62.5
3	a) Annual Electricity Consumption ,Purchased From Utilities(kWh)	102854
	Annual Electricity Consumption, Through Diesel Generating DG Set (kWh)	180
	c) Total Annual Electricity Consumption, Utilities + DG Sets (kWh)	103034
4	a) Annual Cost Electricity Purchased from Utilities (Rs.)	826297
5	Working hours (Mainly day working but Library is 24 hour working)	Built Up Area (sq m) (Excluding Basement Area)
6	Working days/week (e.g. 5/6/7 days per week)	10545
7	Installed lighting load(kW)	6
8	Installed capacity of Air Conditioning System(TR)	7.5
9	Existing EPI(Energy performance Index) in kWh/sq. m/year Energy includes	37.50
	Electricity Purchased & Generated (Excluding Electricity from any Renewable Source)	9.77
10	No. of Floors per building	102854
11	HSD(in Ltr) in the year for Vehicle	2
	HSD(in Ltr) in the year for DG Set	29322.59
12	Occupancy Information	Daily Visitors
		Staff Members
		50
		107

3.1 Analysis of Energy Bill

The energy bills details and tariff categorization details of CUTM, Balangir for FY' 2021-22 having consumer no- 911001030356 is furnished below:

Table: Consumer details of the Building

Consumer Name & Address	JITM (CUTM) at Industrial Growth Centre, Balangir
Tariff Category	GP<110 kVA
Consumer No.	911001030356
Contract Demand	35kW
Supply Voltage	11kV

Data source: Energy Bills of CUTM were collected during the period of Energy audit.

The summary of Energy Bill Analysis of The CUTM, Balangir is furnished below:

Table: Summary of Energy Bill Analysis of CUTM, Balangir

The summary of Energy Bill Analysis of CUTM, Balangir Building is furnished below:

SUMMARY OF THE ENERGY BILLS FOR THE LAST TWO FINANCIAL YEARS OF CUTM BALANGIR							
Year	Description	Electricity consumed in kWh	Avg. MD in kVA	Power Factor	Load Factor	Energy Bill in Rs.	Energy Charge in Rs./kWh
For Financial year 2021-22	Monthly average	8571	50	0.99	2.92	68858	7.6
	Daily Average	286	50	0.99	2.92	2295	7.6

Table: Energy Bill of CUTM, Balangir for FY' 2021-22

SUMMARY OF ENERGY BILL OF THE CUTM BALANGIR FOR FINANCIAL YEAR 2021-22																				
Month	Energy Consumed in kWh	Energy Consumed in kVAh	Av. Load Factor	Av. Power Factor	MD in kW	MD in kVA	Energy Charge in Rs.	Demand Charge in Rs.	PF Penalty (+ve) / PF Incentive (-ve)	Rebate	CSC	TOD Incentive	Overdrawl Penalty	Delay Payment Surcharge	Interest on Security	Meter Rent in Rs.	Electricity Duty	Current Monthly Bill in Rs.	Energy Charge in Rs./kWh	Unit cost in Rs. per kWh
Apr-21	13346	627944	16.4	0.021	1.09	51.6	101304	1410	0	1335	0	0	0	0	0	0	4052	106766	7.6	8
May-21	6510	6536	0.18	0.996	51.39	51.6	49021.3	1410	0	651	0	0	0	0	4886	0	1961	52392	7.5	8
Jun-21	2064	2076	0.05	0.994	51.5	51.8	15512.4	1410	0	206	0	0	0	0	0	0	621	17543	7.5	8.5
Jul-21	5442	0	0	0	0	35	40999.6	1410	0	544	0	0	0	0	0	0	1640	44050	7.5	8.1
Aug-21	10766	652786	17.1	0.016	0.85	51.6	81513.6	1410	0	1076	0	0	0	0	0	0	3261	86184	7.6	8
Sep-21	8586	8608	0.23	0.997	51.47	51.6	64983.9	1410	0	859	0	0	0	0	0	0	2599	68993	7.6	8
Oct-21	11128	11166	0.29	0.997	51.42	51.6	84300.2	1410	0	1113	0	0	0	0	0	0	3372	89082	7.6	8
Nov-21	10130	10162	0.27	0.997	51.43	51.6	76709.6	1410	0	1013	0	0	0	0	0	0	3068	81188	7.6	8
Dec-21	9802	9868	0.26	0.993	51.25	51.6	74202	1410	0	980	0	0	0	0	0	0	2968	78580	7.6	8
Jan-22	5200	5240	0.14	0.992	51.2	51.6	39221.3	1410	0	520	0	0	0	0	0	0	1569	42200	7.5	8.1
Feb-22	3944	3968	0.11	0.994	51.29	51.6	29722.1	1410	0	394	0	0	0	0	0	0	1189	32321	7.5	8.2
Mar-22	15936	0	0	0	0	51.6	120757	1410	0	1594	0	0	0	0	0	0	4830	126997	7.6	8
Total / Av.	102854	1338354	2.92	0.995	51	52	778247	16920	0	10285	0	0	0	0	4886	0	31130	826297	7.6	8
Monthly Average	8571	7203	2.92	1	0	52	64854	1410	0	857	0	0	0	0	407	0	2594	68858	7.6	8
Daily Average	286	240	2.92	1	0	52	2162	47	0	29	0	0	0	0	14	0	86	2295	7.6	8

From the Energy Bill of FY 2021-22 it is observed that average monthly energy consumed was 8571 kWh with average power factor of 0.99.

However in the energy bill of the month of April, July, August 2021 and March 2022, recorded power factor was very low (e.g. power factor of 0.021 in the month of April 2021). It may be because of faulty reading of the meter.

Figure 1: Trend of MD of CUTM, Balangir

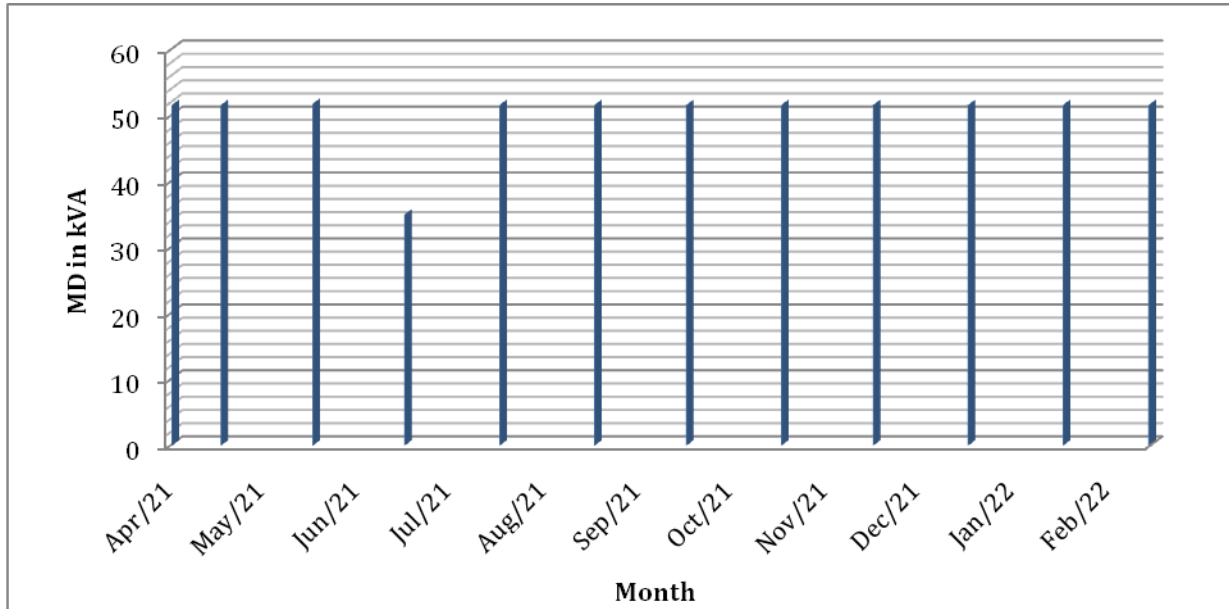

3.2 Base Line Energy Consumption and Specific Energy Consumption

During our audit it is seen that the load drawl pattern of CUTM, Balangir is typical of a unit functioning in day time but the Hostels are functioning beyond office hours. At night time minimum illumination inside the building and full outside lighting with street-lights are maintained. The office working hours in CUTM, Balangir is from 9AM to 6PM normally for 350 days in a year. During the office period normal loads are room lighting, fans, ACs and office appliances. During the entire office working hours the load remains steady with small variations.

Connected load details & corresponding kW consumption

From the inventory survey, it is estimated that there is a connected load of about 81 kW in CUTM, Balangir. It may be seen that the lighting load constitutes about 9% of the total load, the Fan load constitutes about 37% of the total load, the other load constitutes about 8% of the total load and air conditioning loads share about 46% of the total connected load. The following table indicates the estimated connected load details.

Table: Connected load details & corresponding kW

Summary of Electrical Load		
Load Centre	Kilowatt	Load in %
Lighting	7.461	9.26
Fan	29.85	37.07
AC	37.26	46.27
Other Load	5.96	7.40
Total	80.531	100

Figure 2: Pie Chart of Connected Load Details

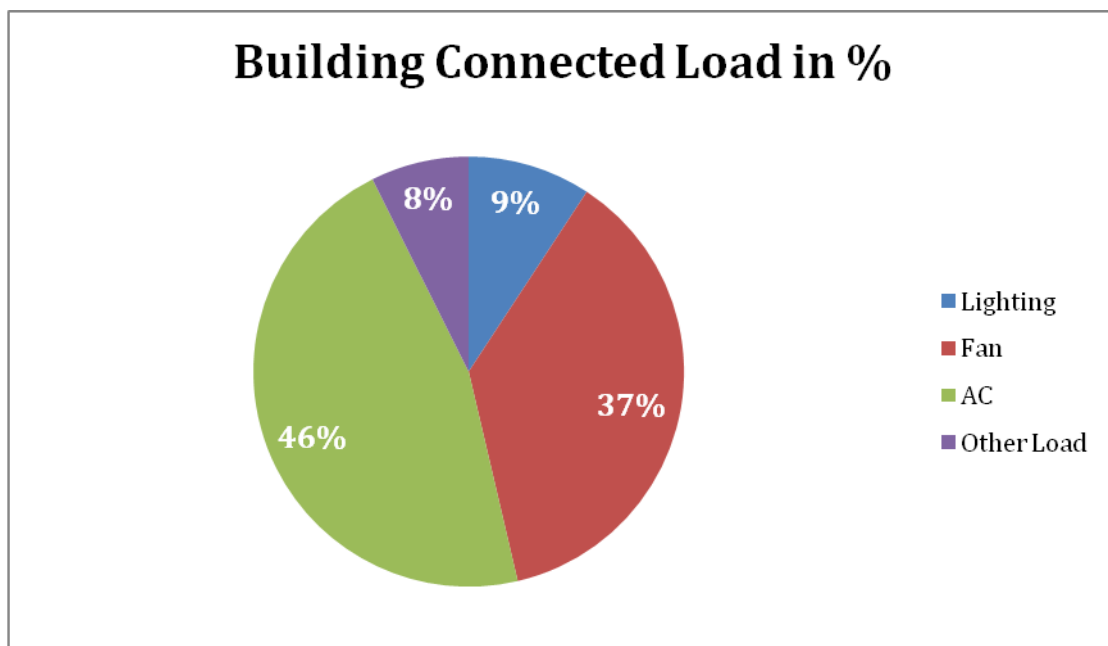

Table: Detailed lighting inventory of all the units of CUTM, Balangir

Lighting Inventory				
Area Name	Types of Load	Wattage of each load in Watt	Nos. installed	Total connected Wattage in Watt
Ground Floor Public School Classroom	Tube Light	36	37	1332
	LED	9	6	54
First Floor Public School classrooms Tube light	Tube light	36	108	3888
First Floor Corridor Public School Tube light	Tube light	36	2	72
	LED	9	6	54
Second Floor Public School Classroom	Tube light	36	38	1368
	LED	9	6	54
Boys Canteen	Tube light	36	17	612
	LED	9	3	27
CUTM Main Building Ground Floor	LED bulb	9	4	36
	LED Tube light	20	12	240
	Fluorescent Light	36	101	3636
CUTM Main Building First Floor	LED bulb	9	3	27
	LED Tube light	20	8	160
	Fluorescent Light	36	112	4032
CUTM Main Building Second Floor	LED bulb	9	1	9
	LED Tube light	20	83	1660
	Fluorescent Light	36	71	2556
Total			618	7461

Table: Detailed inventory of ACs

AC inventory				
Area Name	Types of Load	Wattage of each load in Watt	Nos. installed	Total connected Wattage in Watt
Public School First Floor	Split AC	1500	17	25500
CUTM Ground floor	Split AC	1470	4	5880
CUTM First Floor	Split AC	1470	3	4410
CUTM Second Floor	Split AC	1470	1	1470
Total			25	37260

Table: Detail Inventory of all Types of Fan

Fan Inventory				
Sl. No.	Building Name	Wattage	Quantity	Total connected Wattage in Watt
1	Ground Floor Public School	75	37	2775
2	First Floor	75	89	6675
3	Second Floor	75	36	2700
4	Boys Canteen	75	10	750
5	CUTM Main Building Ground Floor	75	72	5400
6	CUTM Main Building First Floor	75	73	5475
7	CUTM Main Building Second floor	75	81	6075
Total			398	29850

Table: Detail inventory of other appliances

Other appliances inventory				
Area Name	Types of Load	Wattage of each load in Watt	Nos. installed	Total connected Wattage in Watt
Public School Ground Floor	CCTV	15	16	240
Ground Floor Corridor	CCTV	15	8	120
	Computer	125	2	250
First Floor	CCTV	15	16	240
First Floor Corridor	CCTV	15	9	135
Second Floor	CCTV	15	7	105
Second Floor Corridor	CCTV	15	4	60
Boys Canteen	Cooler	150	2	300

	CCTV	15	2	30
CUTM Main Building Ground Floor	Printer	10	0	0
	Cooler	150	0	0
	Projector	150	0	0
	CCTV	15	20	300
	PC	200	4	800
CUTM Main Building First Floor	Projector	150	1	150
	Cooler	150	2	300
	CCTV	15	22	330
	PC	200	13	2600
CUTM Main Building Second Floor	Projector	150	2	300
	Fridge	125	1	125
	Cooler	150	1	150
	PC	200	1	200
	CCTV	15	21	315
Total			128	5960

Energy saving Opportunity:

It is recommended to keep the monitors of the computers in standby mode rather in screen saver mode to reduce the power consumption of the computers when not in use. It is difficult to quantify the saving on account of this measure. The investment will be zero and simple payback period will be immediate.

3.3 Electrical Distribution System and Water Distribution System

The Power Supply system of CUTM, Balangir was studied and based on the observations; the single Line Diagram of existing Electrical distribution system of CUTM is drawn and furnished below.

Figure 3: Electrical Distribution System for 11/0.415 kV Transformer

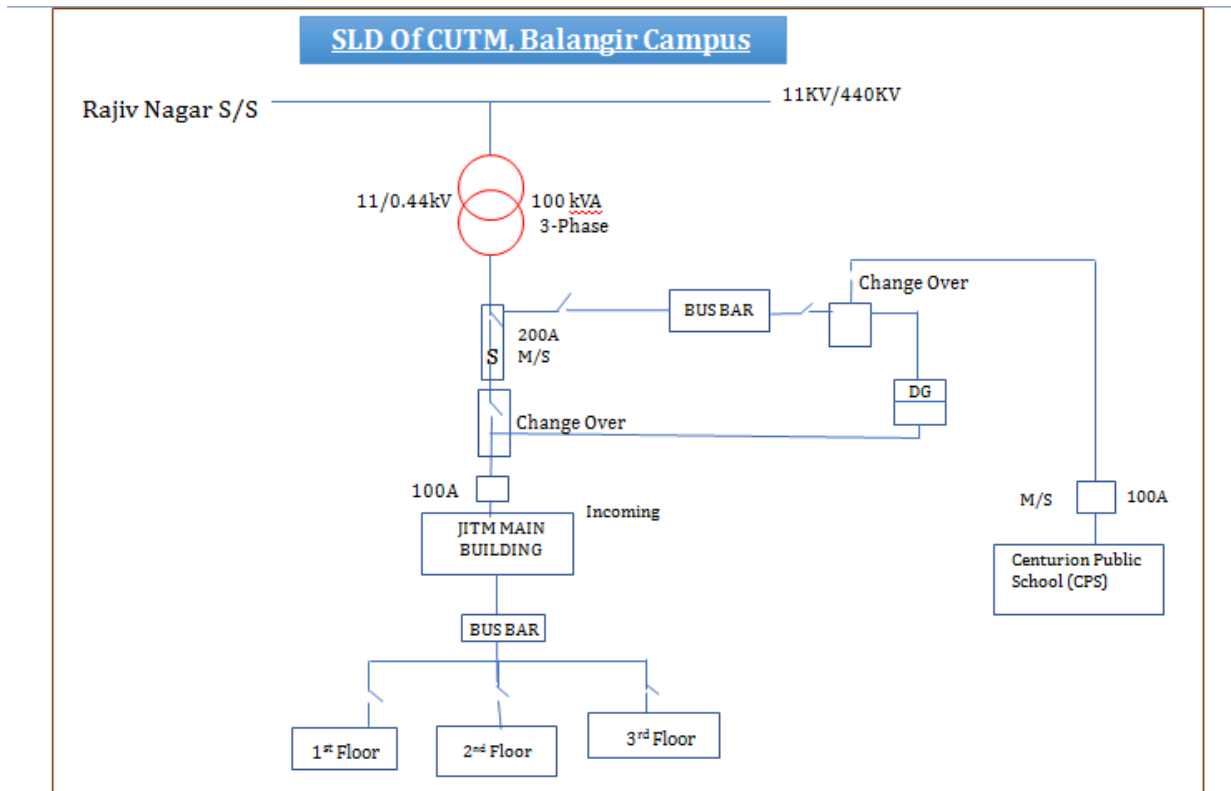
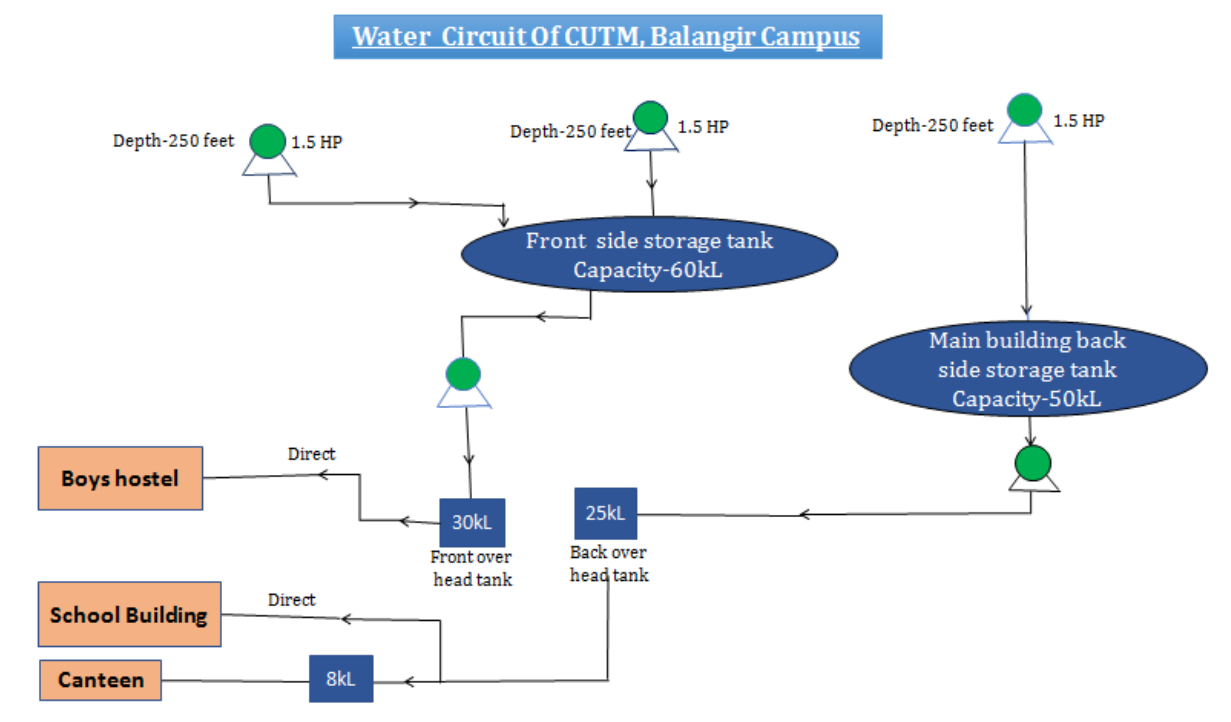

Figure 4: Water Distribution System



3.4 Transformer Details

The technical specification of transformer and its % loading is furnished below:

Table: Technical Specification of Transformer

Particulars	TRF 100kVA
Make	Bidyut Transformers
Transformer rated in kVA	100.00
Rated voltage ratio in kV	11/0.433
Rated current ratio in Amp	5.25/133.33
No. of phase	3.00
Vector diagram	Dyn-11
Type of cooling	ONAN

The power measurement of transformer was carried out by 3 phase power analyzer. The results are attached in Annexure. Based on Average Power measurement data the transformer loadings and efficiency are calculated and furnished below.

Table: Transformer Performance Assessment

Technical data sheet of CUTM, Balangir Transformers	
Particulars	TRF 100kVA
Make	Bidyut Transformers
Transformer rated in kVA	100.00
Rated voltage ratio in kV	11/0.433
Rated current ratio in Amp	5.25/133.33
No. of phase	3
Vector diagram	Dyn-11
Type of cooling	ONAN
Measured voltage at LT side in kV	0.42
Measured current LT Side in Amp	52.23
Measured Power Factor	0.99
No Load Loss (kW)	0.32
Full Load Loss of Transformer (kW)	1.95



Measured load (kVA)	38.18
% Loading on the Transformer (Measured kVA/ Rated kVA)	38.18
Actual Losses of Transformer (kW)	0.60
Total Actual Power Delivered by Transformer in kW	37.79
Transformer Efficiency, %	98.43%
Transformer performance	Satisfactory

Power measurement was carried out at various outgoing cable emanating from the distribution board of each transformer and the results are tabulated below.

3.5 Study of Voltage, Current, Power Factor Profile

Trend of Output voltage profile, Current profile, Output Power profile, Power Factor profile, Voltage unbalance of Load Distributions furnished below.

Table: Voltage Variation and % Unbalance of Load Distribution

POWER									
SL. No.	Area	Incoming/Outgoing	Phase	Voltage in (V)	Current in (A)	PF	kW	Unbalance Voltage (V) in %	Unbalance Current (I) in %
1	Main Building Sec-2	Outgoing	R	235.2	12.3	0.99	14.93	0.03%	87.31%
			Y	235.3	24.6	0.9			
			B	235.2	2.5	0.9			
2	Centurion Public School Section-1	Outgoing	R	235.2	2.3	0.9	8.69	0.03%	106.33%
			Y	235.3	16.3	0.9			
			B	235.2	5.1	0.9			
3	Centurion Public School Section-2	Outgoing	R	235.2	26.1	0.9	19.62	0.03%	100.00%
			Y	235.3	27.4	0.9			
			B	235.3	0	0.9			

Observation

During the audit, high current unbalance was found in the Main Building Sec 2 and Centurion Public School Section 1, Section 2. The measured current unbalance is beyond the permissible level. The effects of unbalanced load are increased heat, reduced lifetime of machine, increased power losses, unreliable motor drives. Therefore it is recommended to have balanced load in all the three phases for efficient performance.

Table: Voltage Variation and %Unbalance of 100 kVA Transformer- CUTM

Voltage Variation and %Unbalance of 100 kVA Transformer- CUTM, Balangir						
Date	Time	Frequency	Phase-1 RMS	Phase-2 RMS	Phase-3 RMS	Vunb
		Hz	V	V	V	%
7/21/22	12:10:00 PM	49.99	424.8	427.8	421.4	0.8
7/21/22	12:10:05 PM	49.99	424.5	428	421.3	0.8
7/21/22	12:10:10 PM	50	424.4	428.3	421.3	0.9
7/21/22	12:10:15 PM	50	424.4	428.3	421.3	0.9
7/21/22	12:10:20 PM	50	424.4	428.1	421	0.9
7/21/22	12:10:25 PM	50	424.5	428.1	421.2	0.9
7/21/22	12:10:30 PM	50	424.4	428.1	421.1	0.9
7/21/22	12:10:35 PM	50.01	424.3	428.2	420.7	0.9
7/21/22	12:10:40 PM	50.02	424.2	428.3	420.5	1
7/21/22	12:10:45 PM	50.02	424	428.4	420.4	1
Average Voltage & %Unbalance			424.53			0.9

Figure 5: Trend of Voltage Variation and %Unbalance of 100 kVA Transformer- CUTM

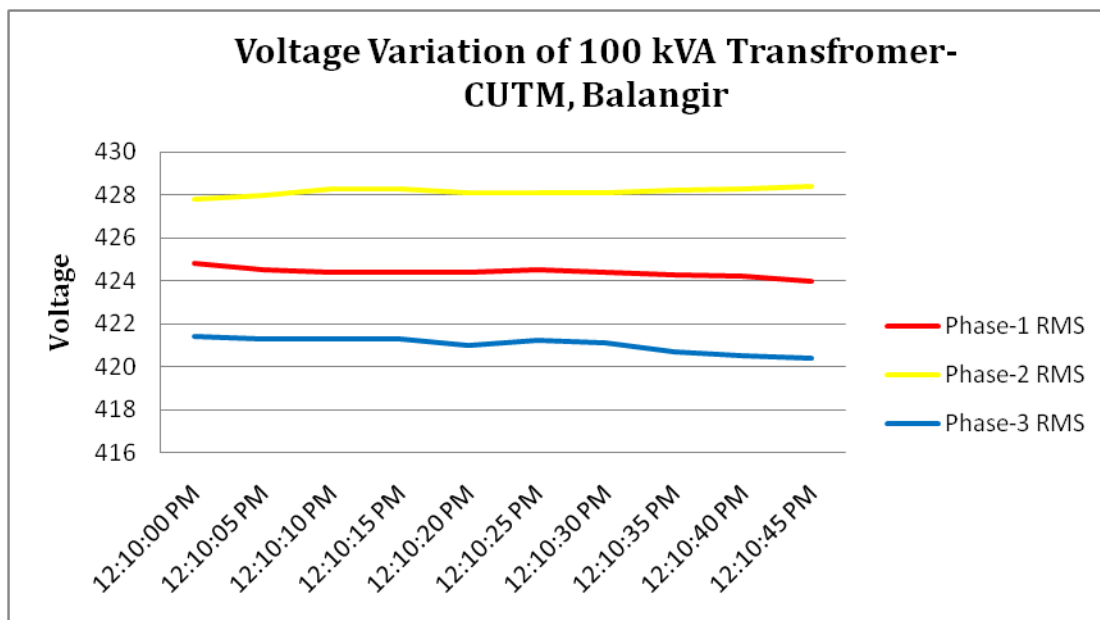

Table: Current Variation and %Unbalance of 100 kVA Transformer- CUTM

Current Variation and %Unbalance of 100 kVA Transformer -CUTM						
Date	Time	Frequency	A1 RMS	A2 RMS	A3 RMS	Aunb
		Hz	A	A	A	%
7/21/2022	12:10:00 PM	49.99	48.6	41.3	58.2	14
7/21/2022	12:10:05 PM	49.99	48.5	41.2	58.1	14
7/21/2022	12:10:10 PM	50	48.6	41.5	58.1	13
7/21/2022	12:10:15 PM	50	48.7	41.5	58.2	13
7/21/2022	12:10:20 PM	50	48.7	41.5	58	13
7/21/2022	12:10:25 PM	50	48.6	41.4	58	13
7/21/2022	12:10:30 PM	50	48.6	41.5	57.6	13
7/21/2022	12:10:35 PM	50.01	48.3	41.4	57.6	13
7/21/2022	12:10:40 PM	50.02	48	41.4	57.6	13
7/21/2022	12:10:45 PM	50.02	48	41.5	57.6	13
Average Current & %Unbalance			49.72			13.2

Figure 6: Trend of Current Variation and %Unbalance of 100kVA Transformer- CUTM

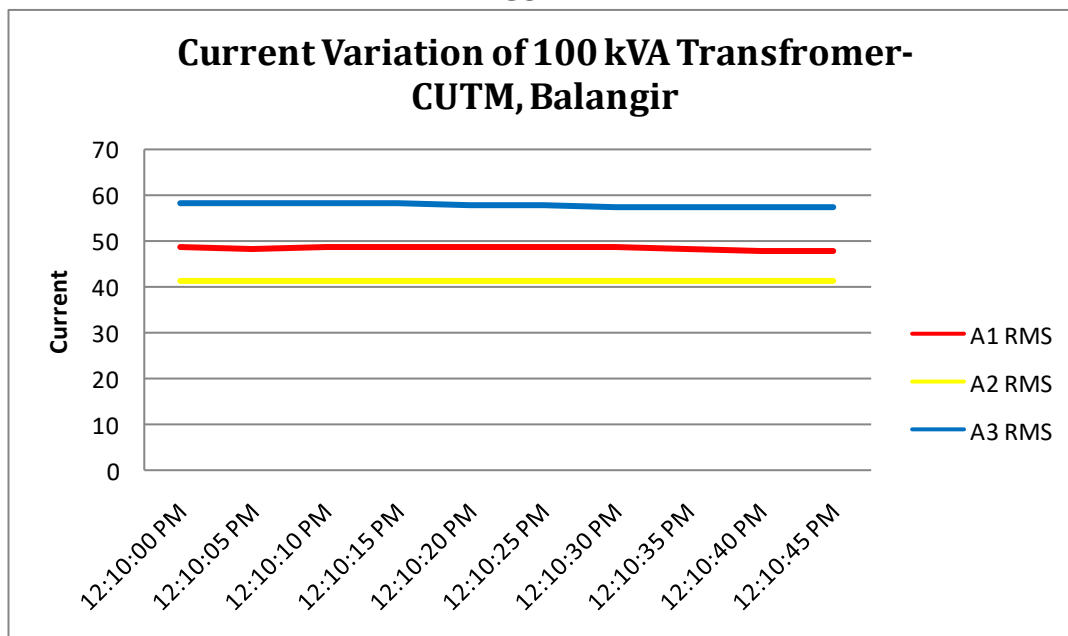

Table: Average Power Factor of 100 kVA Transformer –CUTM

Average Power Factor of 100 kVA Transformer -CUTM						
Date	Time	Frequency	PF1	PF2	PF3	PF Mean
		Hz	Ph-1	Ph-2	Ph-3	Avg.
7/21/2022	12:10:00 PM	49.99	0.99	1	0.99	0.99
7/21/2022	12:10:05 PM	49.99	0.99	1	0.99	0.99
7/21/2022	12:10:10 PM	50	0.99	1	0.99	0.99
7/21/2022	12:10:15 PM	50	0.99	1	0.99	0.99
7/21/2022	12:10:20 PM	50	0.99	1	0.99	0.99
7/21/2022	12:10:25 PM	50	0.99	1	0.99	0.99
7/21/2022	12:10:30 PM	50	0.99	1	0.99	0.99
7/21/2022	12:10:35 PM	50.01	0.99	1	0.99	0.99
7/21/2022	12:10:40 PM	50.02	0.99	1	0.99	0.99
7/21/2022	12:10:45 PM	50.02	0.99	1	0.99	0.99
Average Power Factor						0.99

Table: Snapshot of Load in (W & VA) of 100 kVA Transformer-CUTM

Snapshot of Load in (W & VA) of 100 kVA Transformer-CUTM				
Date	Time	Frequency	Watt Total	Volt Amp Total
		Hz	W	VA
7/21/2022	12:10:00 PM	49.99	35997.4	36298
7/21/2022	12:10:05 PM	49.99	35981.1	36286
7/21/2022	12:10:10 PM	50	36055.5	36355
7/21/2022	12:10:15 PM	50	36044.8	36344
7/21/2022	12:10:20 PM	50	36012.8	36313
7/21/2022	12:10:25 PM	50	36006.8	36310
7/21/2022	12:10:30 PM	50	35895.7	36195
7/21/2022	12:10:35 PM	50.01	35788.1	36091
7/21/2022	12:10:40 PM	50.02	35738.7	36037
7/21/2022	12:10:45 PM	50.02	35741.4	36036
Average			35926	36227

Figure 7: Trend of Load & VA of 100 kVA Transformer-CUTM

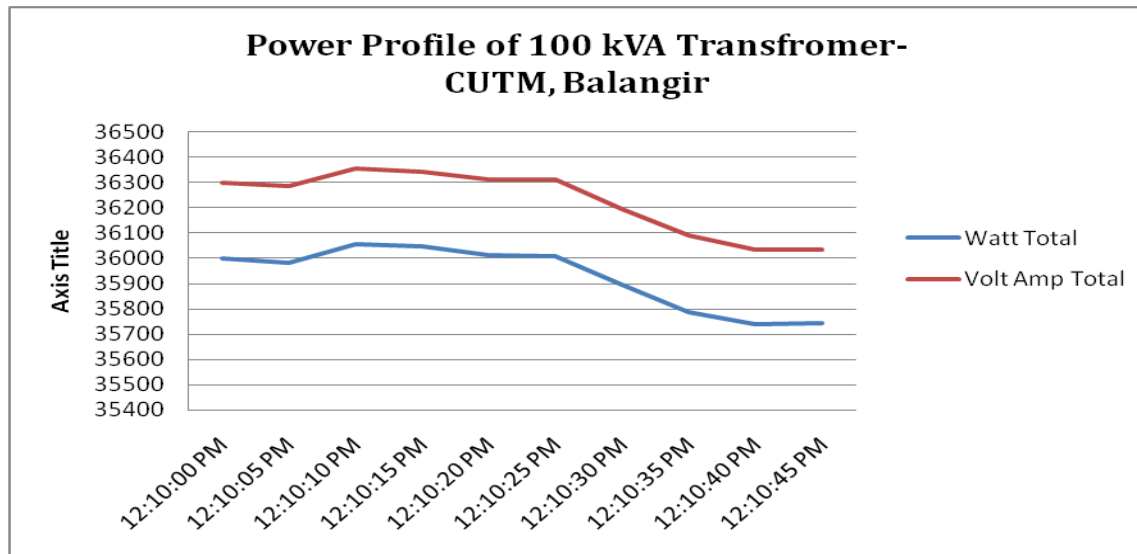

4.0 LIGHTING SYSTEM

4.1 Lighting Inventory

Adequate and proper lighting contributes both directly and indirectly towards productivity and safety, and towards providing an improved work atmosphere. In fact, all these are inter-related and complimentary to each other. There are several factors, which contribute towards proper lighting. However, all efforts were made to study and include these factors during audit of CUTM for lighting loads.

To study, analyze and identify energy conservation options in lighting, a study of the building lighting load was conducted. The purpose of the study was to determine the lighting load and its distribution in various sections of the Building, determine the quality of illumination provided, and recommend measures to improve illumination and reduce electricity consumption.

A high quality and accurate digital LUX meter was used to measure the illumination level at various sections of the building during working hours. Other performance indicators such as type of lamps used, type of luminaries, physical condition of lamps and luminaries, use of day lighting, etc. was also noted down.

During the study, measurement of lighting loads, voltage conditions in the facility areas were carried out. The illumination level was also measured primarily at various classrooms and common areas of the building. Care was taken to reduce the effect of day

lighting while taking the measurements. The recorded inventory is enclosed in tabular form.

To determine the quantity of lighting load a physical count of the light fittings in CUTM, Balangir was carried out. Further, the inputs from the officials and maintenance log books were taken into consideration for calculating the inventory of total light fittings of the CUTM. The total connected load of lighting in CUTM is about 19.817kW. The summarized lighting installations are furnished below.

Table: Total individual lighting calculation of CUTM, Balangir

Lighting Inventory				
Area Name	Types of Load	Wattage of each load in Watt	Nos. installed	Total connected Wattage in Watt
Ground Floor Public School Classroom	Tube Light	36	37	1332
	LED	9	6	54
First Floor Public School class rooms Tube light	Tube light	36	108	3888
First Floor Corridor Public School Tube light	Tube light	36	2	72
	LED	9	6	54
Second Floor Public School Classroom	Tube light	36	38	1368
	LED	9	6	54
Boys Canteen	Tube light	36	17	612
	LED	9	3	27
CUTM Main Building Ground Floor	LED bulb	9	4	36
	LED Tube light	20	12	240
	Fluorescent Light	36	101	3636
CUTM Main Building First Floor	LED bulb	9	3	27
	LED Tube light	20	8	160
	Fluorescent Light	36	112	4032
CUTM Main Building Second Floor	LED bulb	9	1	9
	LED Tube light	20	83	1660
	Fluorescent Light	36	71	2556
TOTAL				19817

4.2 ENCON option for lighting system

Background:

It is observed that there is a scope in energy conservation in lighting system by replacing 36W FL Tube Fittings with 20W LED Tube light. The annual energy saving will be 28051 kWh and financial saving will be around Rs. 1.68Lakh & investment required will be Rs.1.77 Lakh with simple payback period of 1.1 Year.

Cost Benefit Analysis:

Cost Benefit Analysis for Replacement of 36W FL Tube Fittings with 20 W LED Tube light		
Particulars	Unit	Value
Total no. of 36 W FL Tube Fittings	Nos.	487
Total no. of 20W LED Tube Fittings Required	Nos.	487
Present Lighting Load	kW	18
Future Lighting Load after Implementation	kW	9.74
Saving in Load	kW	7.792
Run Hour/day	hr	12
Annual Energy Saving	kWh	28051
Annual Energy Saving	TOE	2.4
Annual Cost of Savings @ Rs.6/unit	Rs.	168307
Investment Required	Rs.	177268
Simple Payback Period	Year	1.1

Background:

It is observed that there is a scope in energy conservation in lighting system by Installation Light pipe Fitting System. By using light pipe system the annual energy saving will 8448 kWh and financial saving will be around Rs.0.49 Lakh & investment required will be Rs. 1.15 Lakh with simple payback period of 2.3 Years.

Cost Benefit Analysis Installation Light pipe Fitting System at CUTM, Balangir		
Particulars	Unit	Value
Total Nos. of Rooms in Boys Hostel Top Floor	Nos.	20
Operating Hour	Hours	8
Avoidance of expected Lighting Load per Annum	kW	3.2
Nos. of Light Pipe System to be Installed	No.	10

Annual Energy Saving @330 Days	kWh	8448
Annual Energy Saving	TOE	0.73
Annual Financial Saving	Rs. in Lakh	0.49
Investment Required	Rs. in Lakh	1.15
Simple Payback Period	Year	2.3

Background:

There is a scope in energy conservation in lighting system by Light Motion Sensor at Boys Canteen. By using motion sensor, the annual energy saving will 345 kWh and financial saving will be around Rs. 2019 & investment required will be Rs. 4248 with simple payback period of 2.1 Years.

Cost Benefit Analysis for Installation of Light Motion Sensor at Boys Canteen		
Particulars	Unit	Value
Total no. of existing 36 W LED fitting	Nos.	17
Total no. of existing 9 W LED fitting	Nos.	3
Present Lighting Load in Boys Canteen	kW	0.64
Future Lighting Load After installation motion sensor considering @15% saving	kW	0.5
Saving in Load	kW	0.1
Run Hour/day	hr	12
Annual Energy Saving	kWh	345
Annual Energy Saving	TOE	0.03
Annual Cost of Savings @ Rs. 6/unit	Rs.	2019
Investment Required	Rs.	4248
Simple Payback Period	Year	2.10

4.3 O & M Practice, Energy Accounting and Monitoring For Lighting System

CUTM electrical maintenance team looks after the operation & maintenance of electric supply, ventilation & air conditioning, lighting system etc. The works involves maintenance of Lighting system, Light replacement, Switching on/off of street light. Solar Street light system installed and maintained by CUTM technicians. But now a days, the timers are available and the street lights are operated automatically. It is observed that there is no proper document available for keeping the records of lighting maintenance, LUX survey, lighting inventory list, area wise lighting consumption etc. A set of well designed format for lighting system record keeping may be developed and maintained at the earliest.

Proper lighting inventory list to be maintained, further during any replacement of lighting system, same may be simultaneously updated in the inventory.

The Monitoring and Targeting programs have been so effective that they show typical reductions in annual energy costs between 5% and 20%.

The essential elements of M&T system are

- Recording: Measuring and recording energy consumption.
- Analyzing: Correlating energy consumption to actual energy consumption
- Comparing: Comparing energy consumption to an appropriate standard or benchmark.
- Setting Targets: Setting targets to reduce or control energy consumption.
- Monitoring: Comparing energy consumption to the set target on a regular basis.
- Reporting: Reporting the results including any variances from the targets which have been set.
- Controlling: Implementing management measures to correct any variances, which may have occurred.

4.4 Illumination Survey and LUX Level Measurement

The Illumination survey of the CUTM Building including Corridor were carried out by measuring the LUX of the different area, Lab, Office Room, Auditorium, Street Light and Class Room using LUX meter and the results are tabulated below.

Table: LUX Measurement

LUX Measurement		
Area	Measured LUX	Recommended LUX
Library	75,80	200-300-500
Office Room	75,80,90	50-100-150
Street Lights	35,45	50-100-150
Class Room	50,55,65,70	200-300-500

It was observed that LUX level of street lights at different location are at average illumination, also there is rare occupancy & less movement in the street light area during night time, so the LUX level is not causing any difficulties.

It is suggested to conduct periodic LUX level survey (preferably once in 3 months) and maintain record properly. Necessary corrective actions should be taken periodically.

Awareness among staff, student and control room operators is to be created for improvement in all aspects of energy conservation especially relating to lighting in their respective wings.

4.5 ENCON Option for Installation of Solar Water Heater

It is recommended that after installation of Solar Water Heater of 500 LPD, the annual LPG saving @300days will be 630 Kg, annual cost saving will be Rs. 0.59 Lakh. Around Rs. 0.7 Lakh of investment will be required and payback period shall be 1.19 years.

Table: Cost Benefit Analysis of Installation of Solar Water Heater

Cost Benefit Analysis of Installation of Solar Water Heater at CUTM Canteen		
Particulars	Unit	Value
Hot Water for Canteen per Day by Solar Water Heater	LPD	500
Consumption of LPG for heating Water	Kg	2.10
Annual LPG Consumption for heating water	Kg	630
Annual Thermal Energy Saving	kCal	7247899
Annual Energy Saving	TOE	1
Annual expenditure due to LPG consumption for solar water heating @ 93.2/Kg	Rs.	58746
Installation Cost of 500 LPD Solar Water Heater	Rs.	70000
Annual financial saving due to reduction in LPG consumption	Rs. Lakh	0.59
Investment required	Rs. Lakh	0.70
Simple Payback Period	Year	1.19

4.6 ENCON Option for Installation of Solar Power Plant in Net Metering Concept

Concept of Net Metering:

Net metering is the concept which records net energy between export of generated energy and import of DISCOM energy for a billing month. Alternatively, the meter, having the feature of recording both the import and export values, also are generally allowed for arriving net energy for the billing period.

Principle of net metering:

Based on available roof area / ground area solar PV panels will be installed. The output of the panels (DC electricity) will be connected to the power conditioning unit / inverter which converts DC to AC. The inverter output will be connected to the control panel or distribution board of the building to utilize the power. The inverter synchronizes with grid and also with any backup power source to produce smooth power to power the loads with preference of consuming solar power first. If the solar power is more than the load requirement, the excess power is automatically fed to the grid. For larger capacity systems connection through step up transformer and switch yard will be used to feed the power to grid.

Advantages of net metering:

The grid connected roof top / ground mounted solar PV system would fulfill the partial / full power needs of large scale buildings. The following are some of the benefits of roof top SPV systems:

- Generation of environmentally clean energy
- Consumer becomes generator for his own electricity requirements
- Reduction in electricity consumption from the grid
- Reduction in diesel consumption wherever DG backup is provided
- Feeding excess power to the grid

It is recommended that after installation of Roof Top at CUTM, Balangir, the annual energy generation will be 99864 kWh, annual cost saving will be Rs. 6 Lakh. Around Rs. 30 Lakh of investments will be required and payback period shall be 5 years.

Table: Cost Benefit Analysis of Establishment of Solar Power Project in CUTM, Balangir

Installation of Roof top Solar Power Plant		
Units Generation	Unit	Value
Total Annual Energy Consumed from TPCODL in FY 2020-21	kWh	102854
Average Base Demand from TPCODL	kW	12
Proposed capacity of the Solar Power Project to be installed	kW	61.796
Total Area Required	Sq. ft.	7415.57
Total Area Available	Sq. ft.	18500
Maximum Solar Project feasible	kW	154
Proposed capacity of the Solar Power Project to be installed	kW	60
Total Project Cost Required	Rs. Lakh	30
Capacity Utilization Factor	%	0.19
Net Annual Generation	kWh	99864

Annual Energy Saving	TOE	8.59
Weighted Average Rate of Electricity	Rs./kWh	6
Annual Saving in Energy Bills due to Consumption from own solar power	Rs. Lakh	6
Simple Payback Period	Years	5.0

Installation of Roof top Solar Power Plant		
Units Generation	Unit	Value
Total Annual Energy Consumed from TPCODL in FY 2020-21	kWh	102854
Average Base Demand from TPCODL	kW	12
Proposed capacity of the Solar Power Project to be installed	kW	61.796
Total Area Required	Sq. ft.	7415.57
Total Area Available	Sq. ft.	18500
Maximum Solar Project feasible	kW	154
Proposed capacity of the Solar Power Project to be installed	kW	60
Total Project Cost Required	Rs. Lakh	30
Capacity Utilization Factor	%	0.19
Net Annual Generation	kWh	99864
Annual Energy Saving	TOE	8.59
Weighted Average Rate of Electricity	Rs./kWh	6
Annual Saving in Energy Bills due to Consumption from own solar power	Rs. Lakh	6
Simple Payback Period	Years	5.0

Implementation:

1. The total project cost to be borne by the consumer, however consumer is eligible for any subsidy / grant from State Govt. / Central Govt. / MNRE as applicable from time to time Implementation of net metering facility shall be made applicable for the consumers having 3-phase supply service connection.
2. Protection system including its switch gear to be certified by concerned Ex. Engineer and harmonic suppressive device to be installed by such SPV generator to suppress the harmonics injection as harmonics is more in case of solar plants where conversion of DC to AC is taking place. Islanding protection requirements to be provided.
3. The SPV generator shall provide the indication of solar PV plant at the injection point for easy identification to the operating personnel.
4. The SPV generator needs to get statutory approvals from appropriate authority like Electrical Inspector for the connected equipment including its solar panels.
5. The proposed generator shall submit the prescribed application to the concerned Executive Engineer of local DISCOM who should be nodal authority for approval of the same.

5. The net meter / meter to be used for arriving net energy shall have the specifications prescribed.
6. Concerned JE of DISCOM shall issue a technical feasibility certificate and witness the synchronization of SPV plant with distribution network.
7. 0.5 class accuracy, tri-vector based energy meter, non ABT having the MRI downloading facility along with related accessories shall have to be installed by the SPV generator as per the specifications of DISCOM.
8. Spot billing is to be arranged by concerned DISCOM as per the billing period. DISCOM shall arrange to develop suitable software and incorporate in the billing instrument for such billing.

It is recommended to install 60 kW Solar Project in CUTM, Balangir.

5.0 HVAC System

At present, the air conditioning system in the CUTM is met through window /split AC of following number. There are around 25 numbers air conditioning systems in CUTM, Balangir.

It is estimated that there is about 37 kW of AC load in CUTM contributing to about 46% of the total connected load.

Installed Air conditioning System of CUTM are furnished below:

Table: Detail Inventory of ACs of CUTM, Balangir

AC Inventory				
Area Name	Types of Load	Wattage of each load in Watt	Nos. installed	Total connected Wattage in Watt
Public School First Floor	Split AC	1500	17	25500
CUTM Ground floor	Split AC	1470	4	5880
CUTM First Floor	Split AC	1470	3	4410
CUTM Second Floor	Split AC	1470	1	1470
Total			25	37260

5.1. ENCON Option for Installation of AC Saver for old 1.5 Ton AC

It is observed that there is a scope in energy conservation in AC system by Installation AC Saver for old 1.5 Ton AC. By using AC Saver, the annual energy saving will be 23693 kWh and financial saving will be around Rs. 1.4 Lakh & investment required will be Rs. 2 Lakh with simple payback period of 1.4 Years.

Cost Benefit Analysis for Installation of AC Saver for Old 1.5 Ton AC		
Particular	Unit	Value
Present nos. of 1.5 Ton AC	Nos.	25
Total Capacity	TR	37.5
Av. Electrical Load of each existing AC before Replacement	kW	1.755
Total Av. Electrical Load before Replacement	kW	43.875
Annual Energy consumption before implementation	kWh	157950
Annual Energy consumption after implementation of AC Saver assuming @15% saving	kWh	134258
Annual Energy Saving due to Installation of AC Saver	kWh	23693
Annual Energy Saving	TOE	2.04
Annual Cost of Savings @ Rs.6.0/unit	Rs. Lakh	1.4
Investment required	Rs. Lakh	2.0
Simple payback period	Years	1.4

Table: EESL-SEAC BOQ (Voltas)

EESL-SEAC BOQ (Voltas)		
Sl.No.	Descriptions of Item	
1	Supply of 1.5 TR split inverter AC, Rated ISEER 5.4. energy efficient 5 Star AC. (indoor unit, outdoor unit, remote control)	1 No.s
a	Refrigeration Piping(Copper) for 1.5 TR Hi wall Unit- (RMT)	3
b	Electrical Cable - (RMT)	3
c	Drain Pipe - (RMT)	3
2	No of Preventive Maintenance Service in a Year	2



Star Rating	Stars	5
Cooling Capacity Full Load (100%)	W	5280
Cooling Capacity Half Load (50%)	W	2640
Cooling Power Full Load	W	1310

(100%)			
Cooling Power Half Load (50%)		W	433
ISEER			5.4
Power Supply		V/Hz/Ph	230 / 50 / 1 Phase
Air Flow Volume - Indoor		CMH	950
*Noise Level - Indoor		..dB(A)	≤46
Operation			LCD Remote
Compressor Type			High EER Twin Rotary - BLDC
Wide Operating Voltage Range		V	145~270
Max operating Ambient Temp Range		Deg C	52 ⁰ C
Refrigerant Gas			R32
Indoor Unit Dimension (WxHxD)		mm	990x315x242
Indoor Unit Net / Gross Weight		Kg	13.5/16.5
Outdoor Unit Dimension (WxHxD)		mm	870x600x355
Outdoor Unit Net / Gross Weight		Kg	33.5/39
Connecting Pipe		type	Cu-Cu(12.5mm & 6.35mm)
Connecting Pipe Length		Meter	3.0
Connecting Cable		Meter	3.0
Condenser Coil			Fin & Tube
No of boxes		ODU	1 Box
		Connecting Tube	
		IDU	1 Box
Features	Filter	Anti Dust	Yes
		Catechin Filter	Yes
		Acaro Bacterium	Yes
		Silver Ion	Yes
	IDU Fin	HydrophilicAluminum	Blue
	Copper tubes	Inner Grooved	Yes
	IDU	LED Display	Yes
		Self Diagnosis	Yes
		Anti Fungal	Yes
		5D Concept	Yes

		Auto Restart	Yes
	Remote	Sleep Mode	Yes
		Turbo	Yes
		Swing	Yes
		LCD Remote	Yes
		Lock	Yes
		Timer	Yes
		Glow Buttons	Yes
		Dual Temp Display	Yes
	Air Vent	Cross Flow	Yes
* Noise level reflects the levels in Anechoic Chamber			
All above performance data are as per IS 1391 Rated conditions.			
No Derating in cooling capacity at 43 degree Celsius.			
	Cost per AC (For Consumer) in INR - (1 Year Comprehensive Warranty & 5 Year Warranty on Compressor)		39990
	Miscellaneous Cost		Voltas
1	Additional warranty for one year i.e. for 2nd year post the expiry of the standard one year warranty ; inclusive of GST	Unit	2200
2	Additional warranty for one year i.e. for 3rd year post the expiry of the standard one year warranty ;inclusive of GST	Unit	2400
3	Copper Pipe ; inclusive of GST	Per Meter	600
4	EPPDM Rubber Insulation for refrigerant piping ; inclusive of GST	Per Meter	90
5	Power Cable ; inclusive of GST	Per Meter	120
6	Drain Pipe ; inclusive of GST	Meter	100
7	Buyback of old Acs ; inclusive of GST	Unit	2500
8	Additional warranty for 4 year (Inclusive of GST)		4000

5.2 Advantages of Inverter Air Conditioner

The latest and the most efficient technology that is available in market today is the Inverter Technology for air conditioners. Inverter technology is designed in such a way that it can save 30-50% of electricity (units consumed) over a regular air conditioner.

Inverter air conditioners are more powerful, offer great savings and are better at maintaining temperature compared to non-inverter air conditioners. When compressor needs more power, it gives it more power. When it needs less power, it gives less power. With this technology, the compressor is always on, but draws less power or more power

depending on the temperature of the incoming air and the level set in the thermostat. The speed and power of the compressor is adjusted appropriately.

Let's take an example of 1.5 Ton inverter air conditioner versus non-inverter air conditioner

A 1.5 Ton inverter air conditioner works initially at 1.7 Ton and as the desired temperature is achieved it reduces its capacity to 1.5, 1 or 0.3 Ton based on room conditions.

A 1.5 Ton non-inverter air conditioner on the other hand works at 1.5 Ton all the times.

Every air conditioner is designed for a maximum peak load. So a 1.5 ton AC is designed for a certain size of room and 1 ton AC for a different size. But not all rooms are of same size. A regular air conditioner of 1.5ton capacity will always run at peak power requirement when the compressor is running. An air conditioner with inverter technology will run continuously but will draw only that much power that is required to keep the temperature stable at the level desired. So it automatically adjusts its capacity based on the requirement of the room it is cooling. Thus, drawing much less power and consuming lesser units of electricity.

5.3 Maintenance Tips for Split / Window AC

- Make sure AC doesn't get overloaded; check the fuse or circuit breaker if it doesn't operate.
- Remember to replace or clean the filter and have your mechanic clean the evaporator and condenser coils regularly, for the air conditioner to cool the home efficiently.
- Install a programmable thermostat, it will lead to 10-15% energy saving.
- Set the thermostat as high as possible comfortable.
- Set the fan speed on high except on very humid days, when humidity is high set the fan speed on low for more comfort.
- Install units in shade, it will lead to 10% saving in energy consumption.
- Use sun films on windows. That will cut heat entry by 70% of the building.
- If the AC makes noise it needs to be checked by the mechanic
- A good air filter will extend the life of the air conditioner because the important parts, like the cooling coil, and other inner parts will stay cleaner, operate more efficiently and last longer.
- Avoid frequent opening of doors/windows. A door kept open can result in doubling the power consumption of your AC.
- Ensure direct sunlight (and heat) do not enter the air-conditioned space, particularly in the afternoons.
- Most people believe that a thermostat set to a lower temperature than desired, will force air-conditioner to cool faster, not really, all it does, is make air-conditioner

operate for longer. Moreover, it will result in unnecessarily chilly room and wasted power. Every degree lower on the temperature setting results in an extra 3-4% of power consumed. Hence, once a comfortable temperature found then set the thermostat at that level, avoid touching the thermostat thereafter.

- Once an air-conditioning system has been designed and installed avoid any major change in the heat-load on the AC. This will add to wasted power.
- Always ensure that whenever new unit is installed, make sure its EER (12/ (kW/TR)) should be between 9.5 to 10.5.
- No gap should be left during installing units for cool air escape.

6.0 Fan Inventory

At present, there are 398 nos. of ceiling fans are available in CUTM campus and it is estimated that there is about 30 kW of Fan load in CUTM contributing to about 37 % of the total connected load.

Table: Fan Inventory

Fan Inventory				
Sl. No.	Building Name	Wattage	Quantity	Total connected Wattage in Watt
1	Ground Floor Public School	75	37	2775
2	First Floor	75	89	6675
3	Second Floor	75	36	2700
4	Boys Canteen	75	10	750
5	CUTM Main Building Ground Floor	75	72	5400
6	CUTM Main Building First Floor	75	73	5475
7	CUTM Main Building Second floor	75	81	6075
Total			398	29850

Energy Conservation Option

It is observed that there is a scope in energy conservation in fan system by replacing Conventional Ceiling Fan with 26W Energy Super Efficient Fan. By using recommended fan the annual energy saving will 54605.6kWh and financial saving will be around Rs.3.27Lakh & investment required will be Rs. 11.26 Lakh with simple payback period of 3.4Years.

Table: Cost Benefit Analysis of Fan

Cost Benefit Analysis for replacing Conventional Ceiling Fan 75W with Super Energy Efficient Ceiling Fan		
Total No. of Fans Operating	Nos.	398
Present Load before Replacement @ 75W per Fan	kW	29.9
Load after Replacement @ 26 W Energy Efficient Super Fan	kW	10.3
Saving in Load	kW	19.5
Run hour /Day	hr	8
Annual Energy Saving Assuming 350 Days	kWh	54605.6
Annual Energy Saving	TOE	4.7
Annual Cost of Savings @ Rs. 6/unit	Rs.	327634
Total Investment Required	Rs.	1126738
Simple Payback Period	Years	3.4

7.0 DIESEL GENERATING (DG) SET

7.1 Observation & Analysis for DG Set

- There is one no. of DG set of 62.5 KVA capacity installed in CUTM to meet the power requirement of the major areas of the building in case of power supply failure from TPWODL.
- The technical specification of the DG Set is furnished below:

Table: Technical specification of the DG set

Technical Specification of DG	
Particulars	DG Set 1
Make	Western Consolidated Private Ltd.
Capacity in kVA	62.5
Phase	3
Rated Voltage in Volt	415
Rated PF	0.8
Rated Speed in RPM	1500
Date of Mfg	12/05/2015
Rated Fuel Consumed in Litre/Hour	1/144

Diesel Consumption of 62.5 kVA DG Set for FY 2021-22 is furnished below:

Table: Diesel Consumption of 62.5 kVA DG Set for FY 2021-22

Month	Diesel Consumption in KL
Apr-21	0.050
May-21	0.050
Jun-21	0.050
Jul-21	0.050
Aug-21	0.050
Sep-21	0.050
Oct-21	0.050
Nov-21	0.050
Dec-21	0.050
Jan-22	0.050
Feb-22	0.050
Mar-22	0.050
Total	0.60

7.2 Recommendation

- The DG set is normally operated in power failure condition and in any emergency load requirement case.
- The details of energy generated and consumption of Diesel for the DG set is not being recorded presently for which the specific energy consumption of DG set could not be evaluated.
- So it is recommended that the DG set generation and HSD consumption details are to be noted monthly basis in log book for future reference and evaluation of SEC.
- The DG set should be inspected by Electrical Inspector; Energy Meter should be installed across the DG set and sealed properly in consultation with Chief Electrical Inspector.
- The record of energy generated in DG set is not available. It is to be recommended that energy meter is to be installed in each DG set and the energy generated in each DG set has to be recorded to calculate the specific energy consumption of DG set.

8.0 TRANSPORTATION

It is observed that the University has 16 numbers of vehicles consisting of 7 numbers of bus, 9 numbers of four wheelers. The list of the vehicles is mentioned below.

Table: Vehicle Detail of CUTM, Balangir

CUTM , Balangir Vehicle Details		
Vehicle Type	What is this used for	Number of vehicles
Bus	College	7
Winger	Office & Guest	3
Magic Van	College	2
Food Van	College	2
Light Vehicle	Office & Guest	2

Recommendation:

It is recommended that either replace the lower efficiency vehicles with Electric Vehicles or they may be operated for smaller distances.

9.0 WATER PUMPING SYSTEMS

9.1 Water Pumping Storage and Distribution System

CUTM meets its water requirement from Ground water through sump storage facility, the pump motors is having various connections like both single and 3-phase connection.

9.2 Utilization of water Pumping System

There are submersible types of pumps installed in CUTM for the auxiliary consumption of water like housekeeping, gardening etc. There are 3 nos. of 1.5HP submersible pumps and 2nos. of 1 HP pumps.

There are submersible types of pumps installed in CUTM for the auxiliary consumption of water like housekeeping, gardening etc. Since, these are submersible type pump, therefore the study mechanical power system could not be carried out and no recommendation is furnished for the same. It is recommended that in future flow meter to be installed and water consumption to be monitored.

9.3 Rain Water Harvesting System

The rainwater harvesting system is one of the best methods practiced and followed to support the conservation of water. Today, scarcity of good quality water has become a significant cause of concern. It is recommended that RWH system may be installed for water conservation.

9.4 Sewage Treatment Plant

The campus has no sewage treatment plants for the primary treatment and management of sewage generated in the campus including its hostel and residential area. It is recommended to install sewage treatment plant so that the treated water can be used for gardening purposes inside the campus. The use of treated water will reduce the ground water use and additionally the treated sludge will be very useful increasing the fertility of the soil.

9.5 Operation and Maintenance of CUTM

CUTM Electrical Maintenance team looks after the operation & maintenance of electric supply, ventilation & air conditioning, lighting system etc. of the entire building to ensure proper work environment and comfort of its residents and officials. There is one Electrician working in CUTM. The work involves maintenance of lift, AC, motor, normal Fuse call Attending, Light replacement, Switching on/off of street light.

9.6 Energy Monitoring & Accounting System

Energy monitoring and targeting (M & T) is primarily a management technique that uses energy information as a basis to eliminate waste, reduce and control current level of energy use and improve the existing operating procedures. It builds on the principle “you can’t manage what you don’t measure”. It essentially combines the principles of energy use and statistics.

While, monitoring is essentially aimed at establishing the existing pattern of energy consumption, targeting is the identification of energy consumption level which is desirable as a management goal to work towards energy conservation.

Monitoring and Targeting is a management technique in which building utilities such as fuel, refrigeration, water, effluent, and electricity are managed as controllable resources in the same way that inventory, building occupancy, personnel and capital are managed. It involves a systematic, disciplined division of the facility into Energy Cost Centers. The utilities used in each centre are closely monitored. Once this information is available on a regular basis, targets can be set, variances can be spotted and interpreted, and remedial actions can be taken and implemented.

The Monitoring and Targeting programs have been so effective that they show typical reductions in annual energy costs in various industrial sectors between 5 and 20%.

The essential elements of M&T system are:

- Recording: Measuring and recording energy consumption.

- Analyzing: Correlating energy consumption to actual energy consumption
- Comparing: Comparing energy consumption to an appropriate standard or benchmark.
- Setting Targets: Setting targets to reduce or control energy consumption.
- Monitoring: Comparing energy consumption to the set target on a regular basis.
- Reporting: Reporting the results including any variances from the targets which have been set.
- Controlling: Implementing management measures to correct any variances, which may have occurred.

The energy used by any business varies with production processes, volumes and input. Determining the relationship of energy use to key performance indicators will allow the Building owner to determine:

- Whether the current energy is better or worse than before
- Trends in energy consumption that reflects seasonal, weekly, and other operational parameters
- How the future energy use is likely to vary Specific areas of wasted energy
- Comparison with other business with similar characteristics - This “benchmarking” process will provide valuable indications

Electrical Safety:

It is observed that the Single Line Diagram (SLD) of the entire electrical system is to be displayed at concerned places. This will help in identifying the fault easily and doing the maintenance job more effectively. The SLD should be reviewed once in year to put necessary changes.

At Panel rooms, the following points are suggested as per safety & electricity rules.

- Rubber mats should be placed on the floor around the PDB panels in each switch room.
- No panel door should be kept open in both sides.
- Proper bunching of cables should be ensured at each switch room. The cables should be clearly tagged at starting & ending points which would help for easy the identification of cables for fault finding & maintenance work.
- Danger plates should be displayed at concerned places.
- Proper naming of loads should be done on each panel.

Awareness and attitude of occupants toward energy efficiency:

It is suggested to create energy conservation awareness among the staff by observing Energy Conservation Day, encouraging & recognizing energy conservation efforts made by any individual or groups. A core committee on Energy Conservation, Electrical Safety, and Resource conservation may also be formed to review the related activities.

10.0 TECHNICAL SPECIFICATIONS FOR ENERGY EFFICIENT PRODUCT

1. Capacitor Bank

Standard parameter	Value/Feature
Total rating of capacitors	40 kVAr
Rated AC Voltage	440Volt
Frequency	50 Hz
No. of Phases	3 phase
Standard	IS 13340-1993
APFC relay	Microprocessor Based
Losses	< 0.2 W/kVAr

2. Lighting

Standard Parameter	Feature
Voltage	220 - 240 V
Shape	Bulb
Lifetime of lamp	15000 hour(s)
Lumen maintenance factor	0.7
Average life (at 2.7 hrs/day)	15.2 year(s)
Number of switch cycles	50000
Rated luminous flux	1400 lm
Rated lifetime	15000 hour(s)
Rated beam angle	150 degree
Light output	1400 lumen
Beam angle	150 degree
Colour temperature	6500 K
Light effect/finish	Cool Daylight
Colour rendering index (CRI)	80
Starting time	<0.5 s
Warm-up time to 60% light	Instant full light
Colour	Cool Daylight

3. Air Conditioner

Standard Parameter	Feature
Split AC (1.5 Ton)	
Cooling Capacity (Watt)	5280
Max Power Consumption (Watt)	1310
Preferable BEE Star Rating	5
Energy Efficiency Ratio (EER)	5.41 W/W
Preferable Compressor Type	Rotary/reciprocating
Preferable Refrigerant Gas	R-32

4. Energy Efficient Fan

Model Name	E1-1200
Reversible Rotation	No
Remote	Yes
Blade Material	Aluminum
Leaf	3

Weight (kg)	4
Dimensions	120 x 140 cm
Down rod Height	30.48 cm
Span (mm/inch)	1200/48
Rated Voltage *	140 - 285
Rated Frequency	48 - 52
Input Power (typical)	26
Power Factor (typical)	0.95
Air Delivery	230

STAR RATING IN ROOM AIR CONDITIONERS

For Unitary Type Air Conditioner

(From 1st January, 2021 to 31st December, 2023)

Indian Seasonal Energy Efficiency Ratio (kWh/kWh)		
Star level	Minimum	Maximum
1 Star	2.7	2.89
2 Star	2.9	3.09
3 Star	3.1	3.29
4 Star	3.3	3.49
5 Star	3.5	

For Split Type Air Conditioner

(From 1st January, 2021 to 31st December, 2023)

Indian Seasonal Energy Efficiency Ratio (kWh/kWh)		
Star level	Minimum	Maximum
1 Star	3.3	3.49
2 Star	3.5	3.79
3 Star	3.8	4.39
4 Star	4.4	4.99
5 Star	5.0”;	

STAR RATING IN DISTRIBUTION TRANSFORMERS

Permissible Limit for Dry Type Transformers

Rating kVA	Max. Losses at 50% loading W*	Max. Losses at 100% loading W*	Max. Losses at 50% loading W*	Max. Losses at 100% loading W*
	Up to 22 kV class		33 kV class	
100	940	2400	1120	2400
160	1290	3300	1420	3300
200	1500	3800	1750	4000
250	1700	4320	1970	4600
315	2000	5040	2400	5400
400	2380	6040	2900	6800
500	2800	7250	3300	7800
630	3340	8820	3950	9200
800	3880	10240	4650	11400
1000	4500	12000	5300	12800
1250	5190	13870	6250	14500
1600	6320	16800	7500	18000
2000	7500	20000	8880	21400
2500	9250	24750	10750	26500

Permissible Limit for Oil Type Transformers

Rating (kVA)	Impedance (%)	Max. Total Loss (W)					
		BEE 1 Star		BEE 3 Star		BEE 5 Star	
		50 % Load	100% Load	50 % Load	100% Load	50 % Load	100% Load
16	4.5	135	440	108	364	87	301
25	4.5	190	635	158	541	128	448
63	4.5	340	1,140	270	956	219	791
100	4.5	475	1,650	392	1,365	317	1,130
160	4.5	670	1,950	513	1,547	416	1,281
200	4.5	780	2,300	603	1,911	488	1,582
250	4.5	980	2,930	864	2,488	761	2,113
315	4.5	1,025	3,100	890	2,440	772	1,920
400	4.5	1,225	3,450	1,080	3,214	951	2,994
500	4.5	1,510	4,300	1,354	3,909	1,215	3,554
630	4.5	1,860	5,300	1,637	4,438	1,441	3,717
1,000	5.0	2,790	7,700	2,460	6,364	2,170	5,259
1,250	5.0	3,300	9,200	3,142	7,670	2,991	6,394
1,600	6.25	4,200	11,800	3,753	10,821	3,353	9,924
2,000	6.25	5,050	15,000	4,543	13,254	4,088	11,711
2,500	6.25	6,150	18,500	5,660	16,554	5,209	14,813

STAR RATING IN PUMP SETS

Star Rating	Performance Factor of the Pump Set
1 Star	≥ 1.00 & < 1.10
2 Star	≥ 1.10 & < 1.20
3 Star	≥ 1.20 & < 1.30
4 Star	≥ 1.30 & < 1.40
5 Star	≥ 1.40

11.0 MOU Format with EESL

MEMORANDUM OF UNDERSTANDING

This Memorandum of Understanding ("MOU"), effective from _____ is to confirm discussions between Energy Efficiency Services Ltd (EESL), a company organized under the laws of India; with its corporate office at 5th & 6th Floor, Core-3, SCOPE Complex, 7-Lodhi Road, New Delhi-110003 and Centurion University of Technology & Management (CUTM) Behind Of BSNL Office, IDCO Land, Indira Nagar, Balangir, Odisha 767001.

Article 1: Purpose and Scope

This MOU confirms the preliminary discussions between CUTM and EESL regarding their intention to enter into transactions or services pertaining to implementation of energy efficiency measures at premises of CUTM.

A. Diagnostic Studies & Pilot Projects

- 1) Energy audits for entire campus to identify avenues for energy saving in electrical and thermal utilities
- 2) Water audits to identify areas/means to reduce specific water consumption
- 3) Lubricant and diesel Conservation Studies
- 4) Pilot studies on Cross-Cutting technologies

B. Implementation of Energy Efficiency Projects through innovative financial models

- 1) Installation/distribution of LED Lights and Energy Efficient appliances (Fans and / or Air Conditioners) across the facilities of CUTM.
- 2) Installation of energy efficient motors (IE3 type) in place of conventional motors
- 3) Installation of Smart Meters

4) Installation of Solar PV Power Projects

C. Capacity Building & Training

- 1) Technical training to campus executives on various topics pertaining to Energy Management, Maintenance Management, Water Management and Safety Engineering
- 2) Organizing suitable study tours and Guest Lectures on suitable topics
- 3) Creating cadre of energy professionals i.e. certified energy managers and auditors
- 4) Facilitating in Certification and Recognition: National Energy Conservation Award, Green Building etc.

EESL in consultation with CUTM shall execute the implementation of Energy Efficiency projects on ESCO Model (Energy Servicing Company). Under this activity, CUTM would provide the inventory list of their facilities / buildings and EESL would submit the Business and Financial proposal based on deemed savings principle leading to signing of Contract Agreements (s).

The activities are advisory services which EESL will provide with consultancy charges after mutual agreement between the Parties. EESL will submit proposals or annual work plans depending upon the requirement from CUTM.

Article 2: Non-Binding MOU for Future Cooperation

This MOU describes the general conditions and arrangements for further discussions between the parties and is non-obligatory. The exact terms and conditions of this future cooperation will be negotiated in due course and delineated in one or more separate and definitive agreements in the future, should circumstances warrant. Neither party shall be liable to the other for any claim, loss, cost, liability or investment opportunities arising out of directly or indirectly related to the other Party's decision to terminate this MOU, the other Party's performance under this MOU, or any other decision with respect to proceeding or not proceeding with the definitive agreement(s) or the Project(s). Further, each party acknowledges and agrees that the decision to enter into definitive agreement is the sole and absolute discretion of the other party.

Article 3: General Terms and Conditions

A) Term: This MOU shall remain in full force and effect for a period of thirty-six (36) months from the effective date, unless it is: (i) superseded by any or all of the definitive documents contemplated in Article 2 (or such other definitive documents as the parties may agree to enter into for their mutual benefit), or (ii) earlier terminated for convenience by the parties in writing by giving 30 (thirty) calendar days' notice.

B) Modification; Waiver; Severability; Assignment: No waiver of any right or remedy on one occasion by either party shall be deemed a waiver of such right or remedy on any other occasion, if any provision of this MOU is held invalid under any applicable law, such holding shall not affect the validity of remaining provisions and same shall continue in full

force and effect. Neither party may assign this MOU, in whole or in part, without the prior written consent of both the non-assigning party.

C) Headings: Headings used in this MOU are for reference purposes only and shall not be used to modify the meaning of the terms and conditions of this MOU.

D) Entire Agreement: This MOU represents the entire understanding and MOU between the parties with respect to the subject matter hereof, and supersedes all prior and contemporaneous communications, representations or agreements, oral or written, regarding the subject matter hereof.

E) Counterparts: This MOU may be executed in two or more counterparts, each of which shall be deemed an original but all of which shall constitute the same MOU. This MOU and any document or schedule required hereby may be executed by facsimile signature that shall be considered legally binding for all purposes.

F) Confidentiality: In recognition of the confidential nature of this MOU and information developed or received hereunder Receiving Party shall not disclose or convey without the prior written consent of Disclosing Party any such technical information received from Disclosing Party or developed under this Agreement to any other party for the duration of the project and for a minimum period of ten (10) years from the date of project completion, termination or short closure. Receiving Party shall establish adequate procedures to prevent such transmittal of such technical information by its current employees.

The undertakings in Articles F shall not apply to the following:

- i. Information which is necessarily disclosed to third parties to enable the performance of work to be carried out in connection with this MOU, provided that the third party receiving the information enters into an agreement to keep the information confidential in accordance with this Article F;
- ii. Information which is ordered to be disclosed by a court of competent jurisdiction;
- iii. Information which is already in the public domain (except because of any breach of this undertaking);
- iv. Information which the party receiving the information can demonstrate from written records was already known to it at the time of receipt of such information from the party disclosing the information.

AGREED AND ACCEPTED:

Centurion University of Technology & Management, Balangir

Energy Efficiency Services Limited

Name:

Designation:

Address:

Name:

Designation:

Address:

5th & 6th Floor, Core-3

SCOPE Complex, 7-Lodhi Road

New Delhi-110003

WITNESS

12.0 ENERGY MANAGEMENT POLICY

Energy management policy provides the foundation for setting performance goals and integrating energy management into an organization's culture. It is a well-known fact that a formal written energy policy acts both as: A public expression of an organization's commitment to energy management and working document to guide energy management practices and provides continuity.

It is the organization's best interest that support for energy management is expressed in a formal written declaration of commitment accompanied by a set of stated objectives, an action plan for achieving them and clear specifications of responsibilities.

The format of energy policy statement is various, but it usually includes the goal or objective of the organization and the more concrete targets in the field of Energy Management (or Energy Conservation). It often shows the major measures and time tables. The statement shall match the organization's mission statement or overall management strategy plan.

The guiding principle of the proposed energy conservation policy should include

- To endeavor for reduction in Specific Consumption of Energy in all forms and in all areas of operations.
- To ensure availability of information and necessary resources for achieving objectives and targets.



- To comply with all applicable legal, regulatory and other requirements related to energy use, consumption and efficiency.
- To espouse Energy Efficient Technology encompassing procurement of Energy Efficient Products and services and design for Energy Performance Improvement.
- To carry out Energy Audits and Energy Reviews at planned intervals to improve Energy performance.

Actual drafting / reviewing of energy policy will depend upon an organizations corporate culture and management style. We feel that the policy will get wider acceptance if all the concerned parties have been given the opportunity to contribute to the proposed amendment. All departmental representatives should be invited to make submission when the policy is reviewed. After the policy is reviewed, it should be approved by the Board and it should be formally adopted. Further it is recommended to form a energy conservation cell in CUTM in which faculty members from electrical department, utility managers, finance manager and senior management representative to be there. They should organize regular monthly meeting and awareness program in the campus. They should also explore possibilities for implementation of energy efficiency and renewable energy project.



Annexure:

1. Format of Energy Bill:

SUMMARY OF ENERGY BILL OF ----- FOR FINANCIAL YEAR -----																			
Month	Energy Consumed in kWh	Av. Load Factor	Av. Power Factor	MD in kW	MD in kVA	Energy Charge in Rs.	Demand Charge in Rs.	PF Penalty (+ve) / PF Incentive (-ve)	Rebate	CSC	TOD Incentive	Overdraw Penalty	Delay Payment Surcharge	Interest on Security	Meter Rent in Rs.	Electricity Duty	Current Monthly Bill in Rs.	Energy Charge in Rs./kWh	Unit cost in Rs. per kWh
Apr																			
May																			
Jun																			
Jul																			
Aug																			
Sep																			
Oct																			
Nov																			
Dec																			
Jan																			
Feb																			
Mar																			
Total / Av.																			
Monthly Average																			
Daily Average																			

2. **Technical Specification of DG Set & Energy Data Sheet of DG:**

Energy Data Sheet of -----kVA DG Set for FY -----			
Month	Diesel Consumption in kL	Total Energy Generated in DG Set in kWh	SEC in Liter/kWh
Apr			
May			
Jun			
Jul			
Aug			
Sep			
Oct			
Nov			
Dec			
Jan			
Feb			
Mar			
Total			

3. **Technical data sheet of ----- Transformers & Transformer Performance Assessment:**

Technical data sheet of ----- Transformers	
Particulars	TRF no.-----
Make	
Transformer rated in kVA	
Rated voltage ratio in kV	
Rated current ratio in Amp	
No. of phase	
Vector diagram	
Type of cooling	
Measured voltage at LT side in kV	
Measured current LT Side in Amp	
Measured Power Factor	

Transformer Performance Assessment	
Details	TRF no.-----
Transformer Rating in KVA	
Measured voltage at LT side in kV	
Measured current in LT Side Amp	
No Load Loss (kW)	
Full Load Loss of Transformer (kW)	
Measured load (kVA)	
% Loading on the Transformer (Measured kVA/ Rated kVA)	
Actual Losses of Transformer (kW)	
Operating Power Factor	
Total Actual Power Delivered by Transformer in kW	
Transformer Efficiency, %	
Transformer performance	

4. LUX Measurement

LUX Measurement		
Area	Measured LUX	Recommended LUX

5. Energy Management Training Program Log Sheet

Energy Management Training Program of CUTM, Paralakhemundi															
Sl. No.	Energy Committee Members	Designation	Ph. No.	April	May	June	July	August	September	October	November	December	January	February	March



13.0 Vender Details of Projects

Vender details for CUTM						
Sl. No	Vendor Name	Service	Address	Phone Number	Email	Website
1	Star Enterprises	Solar Water Heater	205A, Snehalata Apartment, Vivekananda Marg, Bhubaneswar-751002	9040310328/7008527362	starenterprisesbbsr@gmail.com	
2	Lavancha Renewable Energy Pvt.	Solar Water Heater	Ltd. Regus CBD, Level 9, East Wing, Raheja Towers, MG Road, Bengaluru – 560001	99006 66885 / 7348907677	niranjan.patil@lavancha.in / info@lavancha.in	https://www.lavancha.in/
3	Sky shade Daylights Pvt Ltd	Light Pipe system	#401, Jyothi Flora, Plot no. 240, B-Block, Kavuri hills, Madhapur, Hyderabad-500081	91-40 4020 4022/33	marketing@skyshade.in	www.skyshade.in



4	Tanstate Global	Light Pipe system	Regulus, S No 1/10/2, B 801, Balewadi Near PMC School Pune 411045	7219700559	tanstateglobal@gmail.com / tsg@tanstateglobal.com	http://www.tanstateglobal.com
5	KRISHNA ENGINEERS & CONSULTANTS	Biogas Plant	Plot No: 4723, Laxmi Vihar, Lane-3, Sainik School, Bhubaneswar, Odisha, India- 751005	09114160231, 09437256123	krishnaenergy@gmail.com / krishnaenergy2@gmail.com	www.krishnaenergy.com
6	Energy Efficiency Services Limited	AC Replacement	Ground Floor, House No. 409/B, Sahid Nagar, Bhubaneswar, Dist. Khordha Odisha – 751007.	9861486746	info@power-tech.group	
7	Energy Efficiency Services Limited	28W Super Energy Efficient Ceiling Fan	Ground Floor, House No. 409/B, Sahid Nagar,	9861486746	info@power-tech.group	



			Bhubaneswar, Dist. Khordha Odisha - 751007.			
8	Solar Sack (A unit of Nemhans Solution Pvt. Ltd)	Solar Rooftop Project	N4/234,IRC Village, Nayapalli, Bhubaneswar	9238412384	quotation@solarsack.in	
9	UNIFY SOLAR	Solar Rooftop Project	DELHI	9212560106, 9667966755	unifysolar@gmail.com	http://www.unifysolar.in

INVESTMENT GRADE ENERGY AUDIT REPORT
of Centurion University of Technology & Management
Ramchandrapur, Bhubaneswar, Odisha



Submitted to:

Centurion University Of Technology & Management

**Ramchandrapur, P.O. – Jatni, Bhubaneswar, Dist: Khordha,
Odisha, India, PIN- 752050**

Tel +91 82600 77222

Website: www.cutm.ac.in



**Power Tech
Consultants**

Submitted by:

Power Tech Consultants

**Corporate Office: K-8-82, Kalinga Nagar, Ghatikia
Bhubaneswar-751029, Odisha**

Phone: 0674-2954256, Mob: 9937112760, 9437155337

Email: pwrtech@gmail.com

Website: www.pwrtech.com



TABLE OF CONTENTS

ACKNOWLEDGEMENT3
AUDIT TEAM DETAILS4
CERTIFICATE5
EXECUTIVE SUMMARY6
1.0 INTRODUCTION7
 1.1. ABOUT THE SITE7
 1.2. SCOPE OF WORKS8
 1.3. METHODOLOGY9
 1.4. INSTRUMENTS USED..... 10
2.0. ENERGY SCENARIO 10
 2.1. ANALYSIS OF ENERGY BILL 11
 2.2. BASE LINE ENERGY CONSUMPTION AND SPECIFIC ENERGY CONSUMPTION 22
3.0. ELECTRICAL DISTRIBUTION SYSTEM AND TRANSFORMER DETAILS29
 3.1. TRANSFORMER DETAILS 30
 3.2. STUDY OF VOLATAGE, CURRRENT, POWER FACTOR PROFILE 31
4.0. LIGHTING SYSTEM 38
 4.1. O & M PRACTICE, ENERGY ACCOUNTING AND MONITORING FOR LIGHTING SYSTEM 40
 4.2. ILLUMINATION SURVEY AND LUX LEVEL MEASUREMENT 40
 4.3. ENERGY CONSERVATION OPTION 44
 4.4. ENCON OPTION IN LIGHTING SYSTEM 44
 4.5. ELECTRICAL LOAD DISTRIBUTION 45
 4.6. ENCON OPTION FOR INSTALLATION OF SOLAR POWER PLANT IN NET METERING CONCEPT 45
5.0. HVAC SYSTEM 47
 5.1. MAINTENANCE TIPS FOR SPLIT / WINDOW AC 48
6.0. DIESEL GENERATING (DG) SET 48
7.0. WATER PUMPING SYSTEMS 54
 7.1. WATER PUMPING STORAGE AND DISTRIBUTION SYSTEM 54
8.0. FINANCIAL ANALYSIS OF THE IMPLEMENTED ENERGY CONSERVATION PROJECT 55
9.0. OPERATION AND MAINTENANCE OF CUTM 55
10.0. ENERGY MONITORING & ACCOUNTING SYSTEM 55
11.0. TECHNICAL SPECIFICATIONS FOR ENERGY EFFICIENT PRODUCT 57



ACKNOWLEDGEMENT

Power Tech Consultants (PTC) places on record its sincere thanks to Centurion University of Technology & Management for entrusting the task of conducting the Investment Grade Energy Audit of Centurion University of Technology & Management (CUTM), Bhubaneswar.

PTC acknowledges with gratitude the wholehearted support and encouragement given by all CUTM officials while carrying out the study at CUTM.

PTC acknowledges with gratitude and sincerely thanks all the officials and staff members of Centurion University of Technology & Management who have rendered their all possible co-operation and assistance to the study team during the entire period of the Audit.

Our special thanks to Prof. Jagannath Padhi (Director CIT), Prof. K.V.D. Prakash (HR Head), Mr. Chittaranjan Pattanayk, Manager (HR & Admin), Dr. Abhinna Ch Biswal, Dr.S.P.Nanda, Prof. Asish Ranjan Das, Prof. Sandipan Pine, Prof. Surya Narayan Sahu and the whole Energy Policy Members for their whole hearted co-operation and guidance in carrying out the Investment Grade Energy Audit of CUTM.

M/s. Power Tech Consultants

Authorised Signatory

Signature

Bibhu Charan Swain

Sr. Consultant

Accredited Energy Auditor

Regd. No - AEA-0121

Power Tech Consultants

K-8-82, Kalinga Nagar, Ghatikia, Bhubaneswar-751029, Odisha

Phone: 0674-2954256

Mobile: 9937112760, 9437155337

Email: pwrtch@gmail.com, Website: www.pwrtch.com





AUDIT TEAM DETAILS

1. Mr. Bibhu Charan Swain, Sr. Consultant & Accredited Energy Auditor, Regd. No. – AEA-0121
2. Mr. Barada Prasana Subudhi, Asst. Manager (Project)
3. Mr. Nirjhar Biswal (Project Associate)
4. Ms. Monika Kumari (Project Associate)
5. Mr. Suraj Kumar Bhujabal (Project Associate)



CERTIFICATE

We certify the following

- The data collection has been carried out diligently and truthfully.
- All data measuring devices used by the auditor are in good working condition, have been calibrated and have valid certificate from the authorized approved agencies and tampering of such devices has not occurred.
- All reasonable professional skill, care and diligence had been taken in preparing the energy audit report and the contents thereof are a true representation of the facts.
- The investment grade energy audit has been carried out in accordance with the BEE prescribed norms.

M/s. Power Tech Consultants

Signature

Bibhu Charan Swain
(Bibhu Charan Swain)
Authorised Signatory

Bibhu Charan Swain
Sr. Consultant
Accredited Energy Auditor
Regd. No - AEA-0121
Power Tech Consultants
K-8-82, Kalinga Nagar, Ghatikia, Bhubaneswar-751029, Odisha
Phone: 0674-2954256
Mobile: 9937112760, 9437155337
Email: pwrtch@gmail.com, Website: www.pwrtch.com





EXECUTIVE SUMMARY

Centurion University of Technology & Management (CUTM) is the First Multi-Sector State Private University in Odisha, located in Ramchandrapur, P.O. Jatni, Dist-Khurda, Odisha. Established in August 2005, spread over 40 acres of land in the foothill of Barunei hills, near Jatni town, the campus is adjacent to National Institute of Science, Education and Research (NISER), Indian Institute of Technology (IIT), All India Institute of Medical Sciences (AIIMS) and Xavier University. The famous 11th century Lingaraj temple is about 20 kms from this campus. It is the only technological University in South Odisha. The complex includes School of Engineering & Technology, School of Management, School of Applied Science, School of Vocational, Education and Training, School of Pharmacy, School of Media & Communication, School of Paramedics & Allied Health Sciences, School of Forensic Sciences.

Energy Conservation is a major focus and requirement in Commercial and Government Buildings, and hence Centurion University of Technology & Management, officials has entrusted the work of conducting Investment Grade Energy Audit (IGEA) to Power Tech Consultants. The Energy Audit of CUTM was carried out in the period in December – January 2021.

Centurion University of Technology & Management has three distribution transformers of 1000kVA, 500kVA and 250kVA with contract demand of 444.44 kVA (Consumer no. 12125316), 888.88 kVA (Consumer no. 12107417) & 111.00 kVA (Consumer no. 201190008194) and it avails Power Supply from TPCODL, the local DISCOM at 33 kV voltage level. As per electricity bills analysis for FY 2018-19 and FY 2019-20, the monthly electrical energy consumption stands at about 324630 kWh and the monthly energy bill is around Rs.2393076, the average Power Factor is 0.95. The unit cost of Electricity for CUTM is found to be around Rs. 7.00 per unit.

The major Utility of CUTM are Electricity, Water and HSD. The electricity is utilized for lighting, Fans, pumping of water and AC. HSD is consumed in DG set and Transportation.

The various energy conservation option are listed in the report and it is recommended that CUTM may implement the same.



1.0 INTRODUCTION

The Government of India has enacted the Energy Conservation Act, 2001, with the objective of providing sustainable and more efficient management of our energy resources. The aim of EC Act 2001 is to provide the much-needed legal framework and other institutional arrangements so that various energy efficiency improvement drives can be easily launched at the state and national level. In order to implement the various provisions under the EC Act 2001, the Government of India established the Bureau of Energy Efficiency (BEE), to enact and enforce energy efficiency through various regulatory and promotional measures.

Energy Conservation has become a top most priority in today's scenario in order to have a sustainable growth, productivity, enhancement and Environmental Protection. Considering the vast potential of energy savings and benefits of energy efficiency as per the report prepared by National Development Council (NDC) Committee on power, Govt. of India enacted the Energy Conservation Act 2001. Accordingly, the Govt. of India set up the Bureau of Energy Efficiency (BEE) under the provision of the Energy Conservation Act 2001 for development of policies and strategies with a thrust on self regulation and market principles, with the primary objective of reducing energy intensity of the Indian Economy.

Buildings consume significant portion of Energy for lighting, Air Conditioning, Ventilation purpose and hence Energy Conservation is a major focus and requirement in Commercial and Government Buildings. Besides Building owners are focusing Energy Conservation and Energy Efficiency in a larger extent for a higher productivity. Efficient Energy management, Usage of Energy Efficient Technologies and adopting best-practices that would help a Building Owner to reduce their energy cost considerably. Hence in order to identify the energy conservation opportunities and reduce the present energy consumption, Odisha in consultation with CUTM officials has entrusted the work of conducting Investment Grade Energy Audit (IGEA) to Power Tech Consultants. The Energy Audit of CUTM was carried out on 1st February 2021. The scope of work includes collection of existing layout of Building, Collection of various data including lighting inventory, AC list, Pump, Motor and other electrical load list, Collection of Month wise Energy Bill for FY 2018-19 to 2019-20 and available period for FY 2018-20, Power measurement of all running Transformer, Panels, AC, Pump and Motor.

1.1. ABOUT THE SITE

Centurion University of Technology & Management (CUTM) is the First Multi-Sector State Private University in Odisha, located in Ramchandrapur, P.O. Jatni, Dist-Khurda. Established in August 2005, spread over 40 acres of land in the foothill of Barunei hills, near Jatni town, the campus is adjacent to National Institute of Science, Education and Research (NISER), Indian Institute of Technology (IIT), All India Institute of Medical Sciences (AIIMS) and Xavier University. The famous 11th century Lingaraj temple is about 20 kms from this campus. It is the only technological University in South Odisha. The complex includes School of Engineering & Technology, School of Management, School of Applied Science, School of Vocational, Education and Training, School of Pharmacy, School of Media & Communication, School of Paramedics & Allied Health Sciences, School of Forensic Sciences.



1.2. SCOPE OF WORKS

a) **Review of present electricity consumption and fuel oil. Estimation of energy consumption in various loads like lighting, HVAC, DG Set etc in premises of the Building.**

b) **Electrical Distribution system:**

- Review of present electrical distribution from the single line diagram (SLD). Study of operation/loading of distribution transformers, cable loading, normal and emergency loads, electricity distribution in various area/ floors and loss estimation.
- Study of reactive power management and option for power factor improvement, functioning of capacitor banks.
- Study of power quality, like harmonics, current unbalance, voltage unbalance etc.
- Exploring the energy conservation options (ENCON) in the electrical distribution system.

c) **Lighting System**

- Review of present lighting system, lighting inventories etc.
- Estimation of lighting load at various locations like different floors, outside (campus) light, pump house and other important locations.
- Detailed illuminations survey with measurement of LUX level at various locations and comparison with acceptable standards.
- Study of present lighting control system, lighting maintenance systems, present procedure for management of lighting spares and consumables and recommendation for improvement
- Analysis of lighting performance indices like LUX/m² LUX/Watt, LUX/Watt/m² and comparison of the same with benchmark.
- Exploring the possibility of retrofitting option with energy efficient lighting system like LED lamp, control Gears, sensors and automators, voltage regulators and solar based system.
- Developing a suitable lighting energy accounting and monitoring system.
- Exploring the energy conservation options (ENCON) in lighting system.

d) **Heating Ventilation & Air conditioning system (HVAC system)**

- Review of present HVAC system like Spilt AC, Window AC, water coolers and air heater etc.
- Performance assessment of window AC, and Split AC
- Analysis of HVAC performance like estimation of Energy Efficiency Ratio (EER) i.e. (KW/TR) and comparison of the operating data with the design data and recommendation for best prices/standard requirement.
- Exploring the energy conservation options (ENCON) in HVAC system

e) **Diesel Generators (DG) sets**

- Review of DG set operation
- Performance Assessment of DG sets in terms of specific fuel consumption (SFC i.e. KWH/Ltr.), Exploring the energy conservation options (ENCON) in lighting system.



- Exploring the energy conservation options (ENCON) in DG sets.

f) Water pumping system

- Review of water pumping, storage and distribution systems.
- Performance assessment of all major water pumps i.e. power consumption vs. flow delivered, estimation of pump efficiency etc and compare with best practices
- Study the flow control mechanism.
- Study of rational utilization of water pumping system, energy efficient retrofitting etc.
- Exploring the energy conservation option (ENCON) in water pumping system.

g) Motor Load survey

- Conducting the motor load survey.
- Survey of motor loading (% loading) for major electrical drives
- Measurement of all electrical parameters like voltage, current, PF & KW for all running motors and calculation of pump efficiency and suggestion for improvement.
- Study of mechanical power transmission system and suggest for energy efficiency
- Study of rational usage of drives for reducing electrical energy consumption.
- Exploring the ENCON options in electric drive systems

h) Energy Monitoring & Accounting System:

- Detail Review of present energy monitoring & accounting system in terms of metering, record keeping, data logging, periodic performance analysis etc.
- Suggest for procedures for improvement in energy monitoring and accounting system.

i) UPS

- Measurement and analysis UPS loading, redundancy, operating efficiency, load pattern to suggest measures for energy cost reduction, measurement and analysis of Harmonic.

j) Others:

- Review of present maintenance practice, replacement policies and building safety practices as applicable to high rising buildings and recommend for improvement.
- Cost benefit Analysis of each ENCON indicating simple payback period, return of investment (ROI) internal rate of return (IRR)

1.3. METHODOLOGY

The following step by step methodology and approach were adopted to carry out the Investment Grade Energy Audit Report of CUTM. Prior to energy audit, PTC team made a walk through survey of the Building and associated subsystems to assess the followings:-

- The existing layout of Building.
- Collection of various data including lighting inventory, AC list, Pump, Motor and other electrical load list.
- Collection of Month wise Energy Bill for FY 2018-19 to 2019-20.



The methodology was explained / discussed with CUTM officials and GED officials. The broad methodology adopted for the Energy Audit at CUTM is furnished below.

1. The program of visit of energy audit team to site for carrying out the IGEA work was informed to CUTM officials.
2. Data collection and Energy Bill Collection was carried out through discussions with the officials and from past records, log books.
3. Technical specification of equipments and their operating parameters were collected, while visiting the area. The data so collected were analyzed and the deviations were noted.
4. Performance of the major energy consuming equipments was analyzed.
5. Measurement of electrical energy parameters, wherever possible, using portable instruments were carried out.
6. Power Measurement of all running Transformer, Panels, AC was carried out using portable power analyzer brought by PTC for this purpose.
7. Review of present lighting system, lighting inventories collection were carried out. Estimate all lighting load at various locations like different parts of Building, outside area i.e. street lighting and area lighting and other important locations. Also detailed illuminations survey was determined with measurement of LUX level at various locations.
8. Ambient parameters (Temperature, Humidity) were measured using portable test instrument brought by PTC.
9. Energy Conservation option were identified and tabulated on the basis of priority.
10. Draft soft copy of energy audit report comprising of observations and recommendations with adequate financial justification, vendor support data, etc. was prepared and submitted to CUTM for acceptance.
11. Final energy audit report shall be submitted after acceptance of the draft energy audit report.

1.4. INSTRUMENTS USED

PTC have a wide array of latest, sophisticated, portable, diagnostic and measuring instruments to conduct energy audit investigations and analysis. The following special portable instruments are used to carry out various field measurements and analysis during the energy audit period.

- Three Phase Power Analyzer(ALM-30)
- Clamp on electrical power analyzers
- Infrared Non-Contact Thermometer
- Anemometer
- Hygrometer
- Lux meter

2.0. ENERGY SCENARIO

CUTM receives the electrical power supply from TPCODL at 33 kV. The available contract demand of the Building with TPCODL is 1170 KW. The energy fact file of the building is furnished below:



Table 2.1: Energy Fact File of CUTM

Location	:	CUTM
Areas of Utilization of Energy	:	ITOT Building, CENTRUIAN SCHOOL OF RURAL ENTERPRISES MANAGEMENT Building & CENTURIAN INDUSTRIAL TRAINING CENTRE Building
Source of Supply	:	33 KV Distribution Line of TPCODL
Total Contract Demand	:	111.00KVA,888.88KVA & 444.44KVA
Major Loads	:	Lighting & Power, Air Conditioning, Heating & Cooling, , Computers , Printers, Fans, Pump, Motor, DG Set , Household Appliances and Other loads
Usage Hours	:	Mainly 09.00 am to 6.00 pm on all working days
Monthly Energy Consumption	:	Avg. 27491 kWh, 114460 kWh & 38309 kWh per Month based on FY 2019-20
Monthly Energy Bill	:	Avg. Rs. 217552 ,Rs. 816715 & Rs. 422781 per month based on FY 2019-20

2.1. ANALYSIS OF ENERGY BILL

The energy bills details and tariff categorization of CUTM for FY 2018-19 to FY 2019-20 having consumer no- 201190008194, 12107417 & 12125316 are furnished below:

Consumer Name & Address	ITOT, AT- RAMCHANDRAPUR, JATNI, ODISHA	CENTRUIAN SCHOOL OF RURAL ENTERPRISES MANAGEMENT, C/O. SRI M.K. MISHRA. RAMACHANDRAPUR, JATNI, KHORDA, ODISHA	CENTURIAN INDUSTRIAL TRAINING CENTRE, RAMCHANDRAPUR, JATNI, KHORDA, ODISHA, 752055
Category	GPS	SPP	GPS
Consumer No.	201190008194	12107417	12125316
Contract Demand	111.00KVA	888.88KVA	444.44KVA
Tariff Code	HT/GPS/>=110	HT/SPP/>=110	HT/GPS/>=110
Supply Voltage	33 kV	33 kV	33 kV

Data source: Energy Bill of CUTM collected during the period of Energy audit.



The summary of Energy Bill Analysis of The ITOT Building is furnished below:

SUMMARY OF THE ENERGY BILLS FOR THE LAST THREE FINANCIAL YEARS							
Year	Description	Electricity consumed in kWh	Avg. MD in kVA	Avg. Power Factor	Avg. Load Factor	Total Energy Bill in Rs.	Unit cost in Rs. per kWh
For Financial year 2018-19	Total	172280	0	0.92	0.00	1075132	6.24
	Monthly average	43070	0	0.92	0.00	268783	6.24
	Daily Average	1436	0	0.92	0.00	8959	6.24
For Financial year 2019-20	Total	324630	99	0.95	0.43	2053880	6.33
	Monthly average	27491	99	0.95	0.43	186716	6.33
	Daily Average	916	99	0.95	0.43	6224	6.33

The summary of Energy Bill Analysis of Centurion School of Rural Enterprises Management Building is furnished below:

SUMMARY OF THE ENERGY BILLS FOR THE LAST TWO FINANCIAL YEARS							
Year	Description	Electricity consumed in kWh	Avg. MD in kVA	Avg. Power Factor	Avg. Load Factor	Total Energy Bill in Rs.	Unit cost in Rs. per kWh
For Financial year 2018-19	Total	792612	289	0.99	0.21	4734575	5.97
	Monthly average	88068	289	0.99	0.21	526064	5.97
	Daily Average	2936	289	0.99	0.21	17535	5.97
For Financial year 2019-20	Total	1259064	454	0.99	0.36	8121703	6.45
	Monthly average	114460	454	0.99	0.36	812170	6.45
	Daily Average	3815	454	0.99	0.36	27072	6.45



The summary of Energy Bill Analysis of Centurion Industrial Training Centre Building is furnished below:

SUMMARY OF THE ENERGY BILLS FOR THE LAST TWO FINANCIAL YEARS							
Year	Description	Electricity consumed in kWh	Avg. MD in kVA	Avg. Power Factor	Avg. Load Factor	Total Energy Bill in Rs.	Unit cost in Rs. per kWh
For Financial year 2018-19	Total	217863	133	0.94	0.49	2094079	9.61
	Monthly average	58526	133	0.94	0.49	418816	9.61
	Daily Average	1951	133	0.94	0.49	13961	9.61
For Financial year 2019-20	Total	421397	101	0.93	0.31	3785710	8.98
	Monthly average	38309	101	0.93	0.31	344155	8.98
	Daily Average	1277	101	0.93	0.31	11472	8.98

**Table- 2.4: Energy Bills for the Financial Years 2018-2019 of ITOT Building
SUMMARY OF ENERGY BILL OF ITOT BUILDING FOR FINANCIAL YEAR 2018-19**

Month	Energy Consumed in kWh	Av. Load Factor	Av. Power Factor	MD in kW	MD in kVA	Energy Charge in Rs.	Demand Charge in Rs.	PF Penalty (+ve) / PF Incentive (-ve)	Meter Rent in Rs.	Electricity Duty	Current Monthly Bill in Rs.	Energy Charge in Rs./kWh	Unit cost in Rs. per kWh
Apr-18	55335	N/A	N/A	N/A	N/A	N/A	N/A	N/A	N/A	N/A	N/A	N/A	N/A
May-18	43070	N/A	N/A	N/A	N/A	N/A	N/A	N/A	N/A	N/A	N/A	N/A	N/A
Jun-18	43070	N/A	N/A	N/A	N/A	N/A	N/A	N/A	N/A	N/A	N/A	N/A	N/A
Jul-18	43070	N/A	0.92	N/A	N/A	230425	22200	N/A	N/A	18434	268783	6.67	6.24
Aug-18	43070	N/A	0.92	N/A	N/A	230425	22200	N/A	N/A	18434	268783	6.67	6.24
Sep-18	43070	N/A	0.92	N/A	N/A	N/A	N/A	N/A	N/A	N/A	N/A	N/A	N/A
Oct-18	43070	N/A	0.92	N/A	N/A	N/A	N/A	N/A	N/A	N/A	N/A	N/A	N/A
Nov-18	43070	N/A	0.92	N/A	N/A	N/A	N/A	N/A	N/A	N/A	N/A	N/A	N/A
Dec-18	43070	N/A	0.92	N/A	N/A	N/A	N/A	N/A	N/A	N/A	N/A	N/A	N/A
Jan-19	43070	N/A	0.92	N/A	N/A	230425	22200	N/A	N/A	18434	268783	6.67	6.24
Feb-19	43070	N/A	N/A	N/A	N/A	N/A	N/A	N/A	N/A	N/A	N/A	N/A	N/A
Mar-19	43070	N/A	0.92	N/A	N/A	230425	22200	N/A	N/A	18434	268783	6.67	6.24
Total / Av.	172280	N/A	0.92	N/A	N/A	921698	88800	N/A	N/A	73736	1075132	6.67	6.24
Monthly Average	43070	N/A	0.92	N/A	N/A	76808	22200	N/A	N/A	18434	268783	6.67	6.24
Daily Average	1436	N/A	0.92	N/A	N/A	2560	740	N/A	N/A	614	8959	6.67	6.24

From the Energy Bill of FY 2018-19 it is observed that Average Demand in this year is Nil i.e. Nil with an Average Power Factor of 0.92. There is no Power Factor Penalty paid by the University.



The electricity bill of ITOT building for FY'2018-19 has been raised by the local DISCOM on average basis therefore the analysis of energy bill has been carried out for FY' 2019-20 and accordingly recommendation has been furnished.

Table -2.5: Energy Bills for the Financial Years 2019-2020 of ITOT Building

SUMMARY OF ENERGY BILL OF ITOT BUILDING FOR FINANCIAL YEAR 2019-20													
Month	Energy Consumed in kWh	Av. Load Factor	Av. Power Factor	MD in kW	MD in kVA	Energy Charge in Rs.	Demand Charge in Rs.	PF Penalty (+ve) / PF Incentive (-ve)	Meter Rent in Rs.	Electricity Duty	Current Monthly Bill in Rs.	Energy Charge in Rs./kWh	Unit cost in Rs. per kWh
Apr-19	22230								NA				
May-19	29010	0.81	0.93	48.35	52.2	147131	22200	0	1000	11770	165267	6.10	5.70
Jun-19	23820	0.40	0.97	82.00	84.9	127437	22200	0	1000	10195	159586	7.13	6.70
Jul-19	22290	0.26	0.97	113.34	117	119252	29250	0	1000	9540	159307	7.58	7.15
Aug-19	35100	0.47	0.97	100.29	103.2	187785	25800	-192	1000	15023	227530	6.91	6.48
Sep-19	30150	0.47	0.97	90.01	92.7	161303	23175	-92	1000	12904	196695	6.95	6.52
Oct-19	31470	0.38	0.96	112.00	116.7	168365	29175	0	1000	13469	211709	7.16	6.73
Nov-19	28530	0.60	0.96	66.21	69	152636	22200	0	1000	12211	186548	6.97	6.54
Dec-19	24150	0.55	0.91	59.48	65.1	129203	22200	477	1000	10336	161952	7.13	6.71
Jan-20	27000	0.29	0.92	124.74	135	144450	33750	0	1000	11216	190677	7.48	7.06
Feb-20	26700	0.26	0.94	146.30	156	142845	39000	0	1000	11386	205315	8.12	7.69
Mar-20	24180	0.22	0.93	145.53	156	129363	39000	0	1000	10299	189294	8.25	7.83
Total / Av.	324630	0.43	0.95	99	104	1609767	307950	192	11000	128350	2053880	6.72	6.33
Monthly Average	27491	0.43	0.95	99	104	146342	27995	17	1000	11668	186716	6.72	6.33
Daily Average	916	0.43	0.95	99	104	4878	933	1	33	389	6224	6.72	6.33

From the Energy Bill of FY 2019-20 it is observed that Average Demand in this year is 99KW i.e. 104 KVA with an Average Power Factor of 0.95. There is no Power Factor Penalty paid by the University.

**Energy Conservation Option:
Increase of Contract Demand**

Background:

The contract demand of ITOT building is 111KVA however in certain months the maximum demand has increased up to 156 KVA due to which the ITOT building has to pay overdrawl penalty charges to the local DISCOM. In view of the same it is recommended to increase the contract demand of ITOT building to 190 KVA. There will be saving in demand charge of around of Rs. 11250 per month and annual financial saving will be Rs. 135000 per annum. Investment required will be minor and payback period will be immediate.

Cost Benefit Analysis:

Cost Benefit Analysis for Increase of Contract Demand		
Particulars	Unit	Value
Present Contract Demand	kVA	111
Present Maximum Demand	kVA	156
Present Monthly Demand Charge	Rs. Per Month	50250
Future Contract Demand	KVA	195
Future Demand Charge	Rs. Per Month	39000
Monthly Saving in Demand Charge	Rs. Per Month	11250
Annual Saving by increasing the Contract Demand	Rs.	135000
Investment Required	Rs.	Minor
Simple Payback Period	Year	Immediate

Table- 2.6: Energy Bills for the Financial Years 2018-2019 of CSREM Building

SUMMARY OF ENERGY BILL OF CENTRUJIAN SCHOOL OF RURAL ENTERPRISES MANAGEMENT FOR FINANCIAL YEAR 2018-19													
Month	Energy Consumed in kWh	Av. Load Factor	Av. Power Factor	MD in kW	MD in kVA	Energy Charge in Rs.	Demand Charge in Rs.	PF Penalty (+ve) / PF Incentive (-ve)	Meter Rent in Rs.	Electricity Duty	Current Monthly Bill in Rs.	Energy Charge in Rs./kWh	Unit cost in Rs. per kWh
Apr-18	92154	0.34	0.99	380.80	386.4	493023.9	177776	-5199	1000	39442	575128	6.67	6.24
May-18	83502	0.28	1.09	402.17	369	446735.7	177776	-9368	1000	35739	645888	8.16	7.74
Jun-18	75240	0.32	0.99	330.52	334.2	402534	177776	-5513	1000	32203	602447	8.44	8.01
Jul-18	85854	0.32	0.98	365.53	371.4	459318.9	177776	-4523	1000	36746	664197	8.16	7.74
Aug-18	84336	0.27	0.99	419.53	424.2	451197.6	177776	-5975	1000	36096	645074	8.08	7.65
Sep-18	79278	0.00		0.00								0.00	0.00
Oct-18	63540	0.19	0.98	447.84	454.8	339939	177776	-3805	1000	27195	539720	8.92	8.49
Nov-18	59604	0.00		0.00								0.00	0.00
Dec-18	37362	0.30	0.98	168.26	171	199886.7	177776	-2644	1000	15991	388495	10.83	10.40
Jan-19	23598	0.29	0.94	108.11	114.6	126249.3	177776	-1332	1000	9993	310921	13.60	13.18
Feb-19	32664	0.18	0.97	270.07	279	174752.4	177776	-1441	1000	13865	362705	11.53	11.10
Mar-19	68592	0.00		0.00	0			0	0			0.00	0.00
Total / Av.	792611.7	0.21	0.99	289	323	3093637.5	1599984	-39800	9000	247269	4734575	6.29	5.97
Monthly Average	88068	0.21	0.99	289	323	343738	177776	-4422	1000	27474	526064	6.29	5.97
Daily Average	2936	0.21	0.99	289	323	11458	5926	-147	33	916	17535	6.29	5.97



Investment Grade Energy Audit For CUTM

From the Energy Bill of FY 2018-19 it is observed that Average Demand in this year is 289KW i.e. 323 KVA with an Average Power Factor of 0.99. There is no Power Factor Penalty paid by the University.

Table- 2.7: Energy Bills for the Financial Years 2019-2020 of CSREM Building

SUMMARY OF ENERGY BILL OF CENTRUIAN SCHOOL OF RURAL ENTERPRISES MANAGEMENT FOR FINANCIAL YEAR 2019-20													
Month	Energy Consumed in kWh	Av. Load Factor	Av. Power Factor	MD in kW	MD in kVA	Energy Charge in Rs.	Demand Charge in Rs.	PF Penalty (+ve) / PF Incentive (-ve)	Meter Rent in Rs.	Electricity Duty	Current Monthly Bill in Rs.	Energy Charge in Rs./kWh	Unit cost in Rs. per kWh
Apr-19	N/A	N/A		N/A	N/A	N/A	N/A	N/A	N/A	N/A	N/A	N/A	N/A
May-19	82740	0.28	0.98	398.74	408	442659	177776	-2254	1000	35185	518602	6.69	6.27
Jun-19	127794	0.36	0.98	491.89	500.4	683697.9	177776	-5571	1000	54343	898517	7.46	7.03
Jul-19	111552	N/A		N/A	N/A	N/A	N/A	N/A	N/A	N/A	N/A	N/A	N/A
Aug-19	155070	0.35	0.98	593.06	602.4	829624.5	177776	-7267	1000	65969	1052321	7.21	6.79
Sep-19	150054	0.31	0.98	673.06	684	802788.9	177776	-6829	1000	63824	1024066	7.25	6.82
Oct-19	135264	0.33	0.99	558.14	565.2	723662.4	177776	-7848	1000	57529	938850	7.37	6.94
Nov-19	128118	0.36	0.99	488.42	494.4	685431.3	177776	-7686	1000	54482	911075	7.54	7.11
Dec-19	92364	0.50	0.99	246.04	249	494147.4	177776	-6050	1000	39258	696281	7.96	7.54
Jan-20	88554	0.40	0.99	295.92	300	473763.9	177776	-5317	1000	37653	675588	8.05	7.63
Feb-20	98568	0.40	0.99	356.11	360	527338.8	177776	-6735	1000	41905	731006	7.84	7.42
Mar-20	88986	0.27	0.99	438.33	441.6	476075.1	177776	-7347	1000	37794	675397	8.01	7.59
Total / Av.	1259064	0.36	0.99	454	461	6139189.2	1777760	-62905	10000	487943	8121703	6.84	6.45
Monthly Average	114460	0.36	0.99	454	461	613919	177776	-6291	1000	48794	812170	6.84	6.45
Daily Average	3815	0.36	0.99	454	461	20464	5926	-210	33	1626	27072	6.84	6.45



From the Energy Bill of FY 2019-20 it is observed that Average Demand in this year is 454KW i.e. 461 KVA with an Average Power Factor of 0.99. There is no Power Factor Penalty paid by the University.

Table- 2.8: Energy Bills for the Financial Years 2018-2019 of ITI Building

SUMMARY OF ENERGY BILL OF THE PRINCIPAL CENTURIAN INDUSTRIAL TRAINING CENTRE FOR FINANCIAL YEAR 2018-19													
Month	Energy Consumed in kWh	Av. Load Factor	Av. Power Factor	MD in kW	MD in kVA	Energy Charge in Rs.	Demand Charge in Rs.	PF Penalty (+ve) / PF Incentive (-ve)	Meter Rent in Rs.	Electricity Duty	Current Monthly Bill in Rs.	Energy Charge in Rs./kWh	Unit cost in Rs. per kWh
Apr-18	72861	N/A	N/A	N/A	N/A	N/A	N/A	N/A	N/A	N/A	N/A	N/A	N/A
May-18	41115	N/A	N/A	N/A	N/A	N/A	N/A	N/A	N/A	N/A	N/A	N/A	N/A
Jun-18	45138	N/A	N/A	N/A	N/A	N/A	N/A	N/A	N/A	N/A	N/A	N/A	N/A
Jul-18	63969	0.66	0.96	129.77	135.6	335790	88888	0	1000	26863	448545	7.43	7.01
Aug-18	71001	0.69	0.96	139.15	145.2	370202	88888	0	1000	29616	485365	7.25	6.84
Sep-18	74769	0.79	0.96	131.08	136	N/A	88888	0	1000	N/A	505409	N/A	6.76
Oct-18	51402	0.47	0.93	148.38	159.6	N/A	N/A	N/A	N/A	N/A	N/A	N/A	N/A
Nov-18	62031	0.00	N/A	N/A	N/A	N/A	N/A	N/A	N/A	N/A	N/A	N/A	N/A
Dec-18	43602	0.39	0.91	149.47	164.4	233271	88888	1740	1000	18662	340589	8.24	7.81
Jan-19	39291	0.46	0.94	114.28	121.2	210207	88888	0	1000	16817	314171	8.42	8.00
Feb-19	48147	0.00	N/A	N/A	N/A	N/A	N/A	N/A	N/A	N/A	N/A	N/A	N/A
Mar-19	69429	0.00	N/A	N/A	N/A	N/A	N/A	N/A	N/A	N/A	N/A	N/A	N/A
Total / Av.	217863	0.49	0.94	133	142	1149470	444440	1740	5000	91958	2094079	10.03	9.61
Monthly Average	58526	0.49	0.94	133	142	287367	88888	348	1000	18392	418816	10.03	9.61
Daily Average	1951	0.49	0.94	133	142	9579	2963	12	33	613	13961	10.03	9.61



Table- 2.10: Energy Bills for the Financial Years 2019-2020 of ITI Building

SUMMARY OF ENERGY BILL OF THE PRINCIPAL CENTURIAN INDUSTRIAL TRAINING CENTRE FOR FINANCIAL YEAR 2019-20													
Month	Energy Consumed in kWh	Av. Load Factor	Av. Power Factor	MD in kW	MD in kVA	Energy Charge in Rs.	Demand Charge in Rs.	PF Penalty (+ve) / PF Incentive (-ve)	Meter Rent in Rs.	Electricity Duty	Current Monthly Bill in Rs.	Energy Charge in Rs./kWh	Unit cost in Rs. per kWh
Apr-19	N/A	N/A	N/A	N/A	N/A	N/A	N/A	N/A	N/A	N/A	N/A	N/A	N/A
May-19	73515	0.72	0.94	136.34	145.2	379460	88888	N/A	1000	30357	404502	5.92	5.50
Jun-19	462	0.01	0.94	68.59	72.6	2472	88888	N/A	1000	198	91894	199.33	198.90
Jul-19	35847	0.08	0.98	635.99	646.2	596803	177776	-5468	1000	47386	805566	23.79	22.47
Aug-19	47139	0.70	0.96	90.07	93.6	244464	88888	0	1000	19557	350826	7.86	7.44
Sep-19	45756.5	N/A	0.92	N/A	N/A	244797	88888	N/A	N/A	19584	350183	8.08	7.65
Oct-19	45756.5	N/A	0.92	N/A	N/A	244797	88888	N/A	N/A	19584	350183	8.08	7.65
Nov-19	45756.5	N/A	0.92	N/A	N/A	244797	88888	N/A	N/A	19584	350183	8.08	7.65
Dec-19	45756.5	N/A	0.92	N/A	N/A	244797	88888	N/A	N/A	19584	350183	8.08	7.65
Jan-20	31956.1	0.75	0.91	56.92	62.4	163696	88888	N/A	1000	12995	264056	8.67	8.26
Feb-20	23904	0.56	0.94	61.06	64.8	127886	88888	N/A	1000	10126	227075	9.92	9.50
Mar-20	25548	0.53	0.86	64.77	75.6	136682	88888	7094	1000	10820	241059	9.86	9.44
Total / Av.	421397.1	0.48	0.93	159	166	2630652	1066656	1626.20	7000	209774	3785710	9.48	8.98
Monthly Average	38309	0.48	0.93	159	166	239150	96969	148	636	19070	344155	9.48	8.98
Daily Average	1277	0.48	0.93	159	166	7972	3232	5	21	636	11472	9.48	8.98

**Energy Conservation Option:
Reduction of Contract Demand**

Background:

The contract demand of ITI building is 444.44KVA however in certain months the maximum demand has decreased up to 166 KVA due to which the ITI building is paying unnecessary demand charges to the local DISCOM. In view of the same it is recommended to decrease the contract demand of ITI building to 207.5 KVA. There will be saving in demand charge of around of Rs. 47388 per month and annual financial saving will be Rs. 568656 per annum. Investment required will be minor and payback period will be immediate.

Cost Benefit Analysis for Reduction of Contract Demand		
Particulars	Unit	Value
Present Contract Demand	kVA	444.44
Present Maxium Demand	kVA	166
Present Monthly Demand Charge	Rs. Per Month	88888
Future Contract Demand	KVA	207.5
Future Demand Charge	Rs. Per Month	41500
Monthly Saving in Demand Charge	Rs. Per Month	47388
Annual Saving by Decreasing the Contract Demand	Rs.	568656
Investment Required	Rs.	Minor
Simple Payback Period	Year	Immediate



2.2. BASE LINE ENERGY CONSUMPTION AND SPECIFIC ENERGY CONSUMPTION

During our observation it is seen that the load drawl pattern of CUTM is typical of a unit functioning in day time but the Hostel and Admin building, are functioning in day time beyond office hours, at night time minimum illumination inside the building and full outside lighting with street-lights is maintained. The office working hours in CUTM is from 09 AM to 5PM normally for 350 days in a year. During the office period normal loads are room lighting, fans, ACs and office appliances. During the entire office working hours the load remains steady with small variations.

Connected load details & corresponding KW consumption

From the inventory survey, it is estimated that there is a connected load of about 1170 KW in CUTM. It may be seen that the lighting load constitutes about 10.3% of the total load, and air conditioning loads share about 40% of the total connected load. The following table indicates the estimated connected load details (KW)

Load Centre	Kilo Watt
Lighting	120
Fans	488
AC System	466
Other Load	96
TOTAL	1170

Chart 2.4 Connected load details & corresponding KW consumption

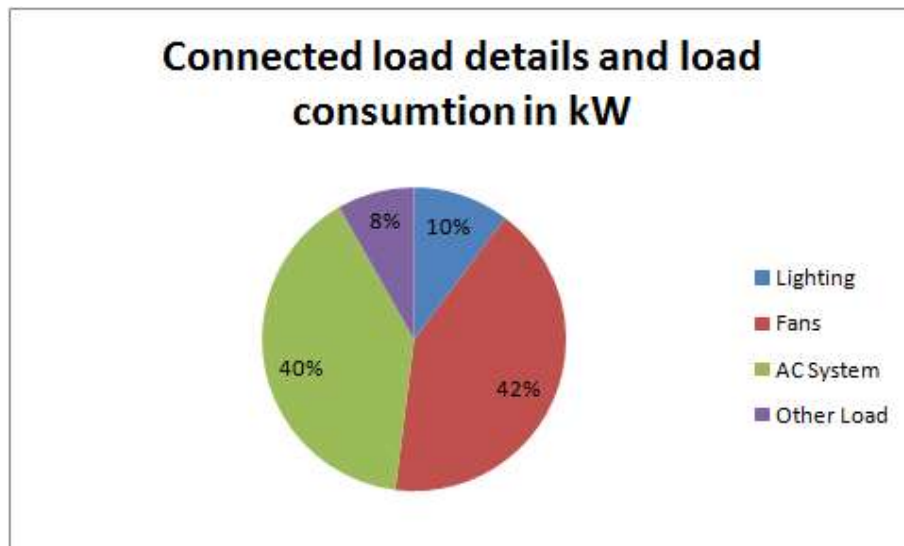



Detail inventory of all the units of CUTM

Lighting Inventory				
Area Name	Types of Load	Wattage of each load in Watt	Nos. installed	Total connected Wattage in Watt
Boy's Hostel	LED	9	257	2313
	LED	20	486	9720
	LED	40	64	2560
	LED	85	16	1360
	LED Tube	20	264	5280
	LED Tube	40	125	5000
	LED Tube	50	27	1350
	LED Tube	60	243	14580
	LED Tube	70	6	420
	LED Tube	80	119	9520
	LED Tube	100	69	6900
	LED Tube	160	24	3840
	LED Tube	180	27	4860
	LED Tube	200	10	2000
	Tube	120	6	720
	Tube	160	8	1280
Girl's Hostel	LED Tube	160	24	3840
	Tube	160	8	1280
MBA	LED	20	2	40
	LED	25	2	50
	LED Tube Light	40	123	4920
	LED Tube Light	25	71	1775
Main Building	LED	9	2	18
	LED Tube Light	20	75	1500
	C.LIGHT	20	25	500
	C.LIGHT	60	228	13680
	Tube Light	40	430	17200
Madhusudan Building	LED Tube light	18	206	3708
	Siling light	30	215	6450
	Fluorescent Tube light	40	348	13920
	Small Led	9	64	576
Other Units	LED	10	69	690
	LED	20	8	160



Investment Grade Energy Audit For CUTM

	LED	36	178	6408
	LED	100	1	100
	Tube Light	40	322	12880
	Halogen Light	50	10	500
	CFL	150	6	900
Total		1991	2947	120214

Detail Inventory of ACs of CUTM				
Type of Load	Watt	Rated Tonnage	Number	Tonnage
Air-conditioner	750	0.5	1	0.5
	1000	1	5	5
	1500	1.5	213	319.5
	2000	2	10	20
	3500	5	4	20
Total	25125		233	365



Detail Inventory of Fans of CUTM			
Type of Load	Wattage of each load in Watt	Number	Total connected Wattage in Watt
Fan	35	15	525
	40	153	6120
	75	316	23700
	80	3875	310000
	100	464	46400
	160	480	76800
	400	60	24000
Total		5363	487545

TOTAL OTHER LOAD			
Type	Watt	Quantity	Total connected Wattage in Watt
OTHER	15	28	420
	20	20	400
	40	10	400
	75	28	2100
	80	59	4720
	100	232	23200
	150	19	2850
	250	3	750
	765	4	3060
	1000	33	33000
	1180	2	2360
	1500	2	3000
	2000	1	2000
	2900	1	2900
	3000	4	12000
	28.4	1	28.4
	60	8	480
	200	4	800
	700	1	700
	1170	1	1170
TOTAL			96338.4



Energy Conservation Option:

Replacement of Old 1.5 & 2 Ton AC with EESL 1.5 ton 5 Star Energy Efficient AC

Recommendation:

It is recommended that after replacement of old Ac, the annual energy saving will be 228942 kWh, annual cost saving will be Rs. 1373652. There is Rs. 9277680 investment required and payback period will be 6.8 years.

Cost Benefit Analysis:

Cost Benefit Analysis for Replacement of Old 1.5 & 2 Ton AC with EESL 1.5 ton 5 Star Energy Efficient AC		
Particular	Unit	Value
Present 1,1.5, 2 & 5 Ton AC	Nos.	233
Total Capacity	TR	365
Present Load before Replacement	kW	1283.65
Annual Energy consumption without Energy Efficient AC @350*12hr	kWh	5391330
After installing 1.5 Ton EESL Energy Efficient AC	TR	348
EESL Energy Efficient AC	kW	1229.14
Annual Energy consumption with EESL AC @365*12hr	kWh	5162388
Annual Energy Saving due to EESL AC	kWh	228942
Annual Cost of Savings @ Rs.6.0/unit	Rs	1373652
Investment required	Rs.	9277680
Simple payback period	Years	6.8

EESL-SEAC BOQ (Voltas)		
S.No.	Descriptions of Item	
1	Supply of 1.5 TR split inverter AC, Rated ISEER 5.4. energy efficient 5 Star AC. (indoor unit, outdoor unit, remote control)	1 Nos
a	Refrigeration Piping(Copper) for 1.5 TR Hi wall Unit- (RMT)	3
b	Electrical Cable - (RMT)	3
c	Drain Pipe - (RMT)	3
2	No of Preventive Maintenance Service in a Year	2



Star Rating	Stars	5	
Cooling Capacity Full Load (100%)	W	5280	
Cooling Capacity Half Load (50%)	W	2640	
Cooling Power Full Load (100%)	W	1310	
Cooling Power Half Load (50%)	W	433	
ISEER		5.4	
Power Supply	V/Hz/Ph	230 / 50 / 1 Phase	
Air Flow Volume - Indoor	CMH	950	
*Noise Level - Indoor	..dB(A)	≤46	
Operation		LCD Remote	
Compressor Type		High EER Twin Rotary - BLDC	
Wide Operating Voltage Range	V	145~270	
Max operating Ambient Temp Range	Deg C	52° C	
Refrigerant Gas		R32	
Indoor Unit Dimension (WxHxD)	mm	990x315x242	
Indoor Unit Net / Gross Weight	Kg	13.5/16.5	
Outdoor Unit Dimension (WxHxD)	mm	870x600x355	
Outdoor Unit Net / Gross Weight	Kg	33.5/39	
Connecting Pipe	type	Cu-Cu(12.5mm & 6.35mm)	
Connecting Pipe Length	Metre	3.0	
Connecting Cable	Metre	3.0	
Condenser Coil		Fin & Tube	
No of boxes	ODU	1 Box	
	Connecting Tube		
	IDU	1 Box	
Features	Filter	Anti Dust	Yes
		Catechin Filter	Yes
		Acaro Bacterium	Yes
		Silver Ion	Yes



	IDU Fin	Hydrophylic Aluminium	Blue
	Copper tubes	Inner Grooved	Yes
	IDU	LED Display	Yes
		Self Diagnosis	Yes
		Anti Fungal	Yes
		5D Concept	Yes
		Auto Restart	Yes
		Sleep Mode	Yes
	Remote	Turbo	Yes
		Swing	Yes
		LCD Remote	Yes
		Lock	Yes
		Timer	Yes
		Glow Buttons	Yes
		Dual Temp Display	Yes
Air Vent	Cross Flow	Yes	

* Noise level reflects the levels in Anechoic Chamber
All above performance data are as per IS 1391 Rated conditions

No Derating in cooling capacity at 43 degree Celsius

Cost per AC (For Consumer) in INR – (1 Year Comprehensive Warranty & 5 Year Warranty on Compressor)				39990
Miscellaneous Cost				Voltas
1	Additional warranty for one year i.e. for 2nd year post the expiry of the standard one year warranty ; inclusive of GST	Unit		2200
2	Additional warranty for one year i.e. for 3rd year post the expiry of the standard one year warranty ;inclusive of GST	Unit		2400
3	Copper Pipe ; inclusive of GST	Per Meter		600
4	EPPDM Rubber Insulation for refrigerant piping ; inclusive of GST	Per Meter		90
5	Power Cable ; inclusive of GST	Per Meter		120
6	Drain Pipe ; inclusive of GST	Meter		100
7	Buyback of old Acs ; inclusive of GST	Unit		2500
8	Additional warranty for 4 year (Inclusive of GST)			4000



3.0. ELECTRICAL DISTRIBUTION SYSTEM AND TRANSFORMER DETAILS

The Power Supply system of CUTM was studied and based on the observations, the single Line Diagram of Existing Electrical distribution system of CUTM is drawn and enclosed below.

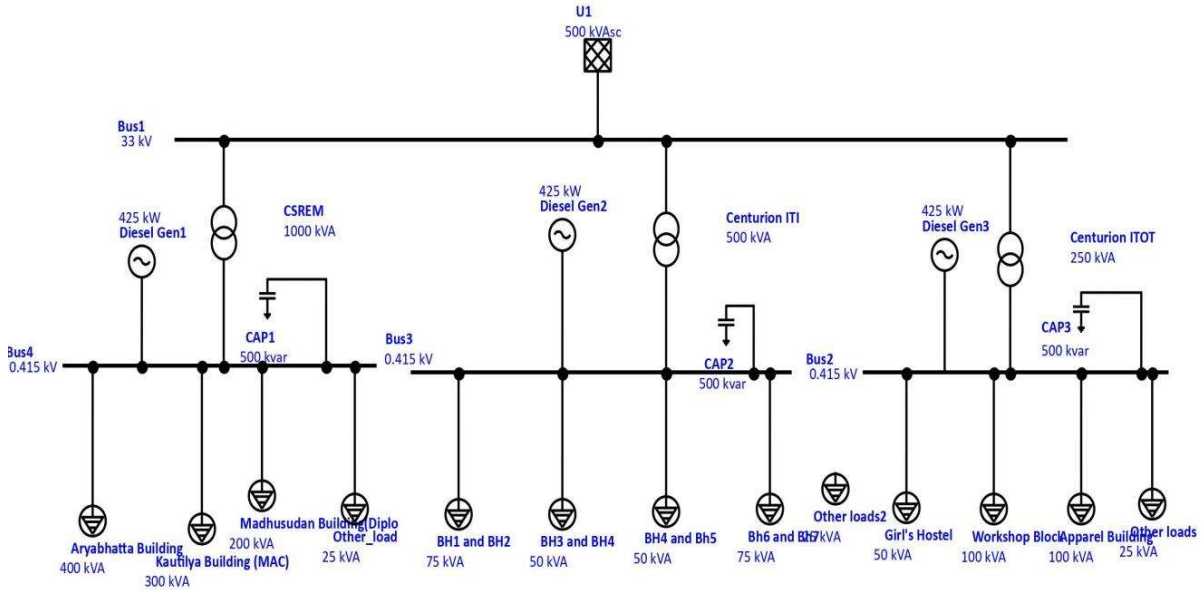

3.1. TRANSFORMER DETAILS

The technical specification of transformer and its % loading is furnished below:

Table 3.1: Technical specification of transformer

Technical data sheet of CUTM Transformers			
Particulars	TRF-1	TRF-2	TRF-3
Make	Gram Tarang Employability Training Services Pvt. Ltd.	ALFA Transformers Ltd.	ALFA Transformers Ltd.
Transformer rated in kVA	250.00	500.00	1000.00
Rated voltage ratio in kV	33/0.433	33/0.433	33/0.433
Rated current ratio in Amp	4.37/333.34	8.75/666.60	17.49/1333.3
No. of phase	3.00	3.00	3.00
Vector diagram	Dyn-11	Dyn-12	Dyn-13
Type of cooling	ONAN	ONAN	ONAN
Measured voltage at LT side in kV	0.43	0.41	0.41
Measured current LT Side in Amp	17.80	233.09	79.68
Measured Power Factor	0.791	0.99	0.91

The power measurement of each transformer is carried out by 3 phase power analyzer. The results are attached in Annexure. Based on Average Power measurement data the transformer loadings and efficiency are calculated and furnished below.

Transformer Performance Assessment

Transformer Performance Assessment			
Details	TRF-1	TRF-2	TRF-3
Transformer Rating in KVA	250.00	500.00	1000.00
Measured voltage at LT side in kV	0.43	0.41	0.41
Measured current in LT Side Amp	17.80	233.09	79.68
No Load Loss (kW)	0.64	0.90	1.80



Full Load Loss of Transformer (kW)	4.45	6.45	13.30
Measured load (kVA)	13.26	167.14	57.13
% Loading on the Transformer (Measured kVA/ Rated kVA)	5.30%	33.43%	5.71%
Actual Losses of Transformer (kW)	0.64	0.90	1.80
Operating Power Factor	0.79	0.987	0.905
Total Actual Power Delivered by Transformer in kW	10.49	164.96	51.71
Transformer Efficiency, %	94.25%	99.46%	96.64%
Transformer performance	Not satisfactory	Satisfactory	Not satisfactory

Power measurement was carried out at the various outgoing cable emanating from the distribution board of each transformer and the results are tabulated.

3.2. STUDY OF VOLATAGE, CURRRENT, POWER FACTOR PROFILE

Trend of Output voltage profile, Current profile, Output Power profile, Power Factor profile, Voltage Unbalance and Current unbalance of Transformer 1, 2 and 3 are furnished below.

Voltage Variation and %Unbalance of 1000 kVA Transformer						
Date	Time	Frequency	Phase-1 RMS	Phase-2 RMS	Phase-3 RMS	Vunb
		Hz	V	V	V	%
1/30/2021	11:42:00 AM	50.08	413	417.4	416.2	0.5
1/30/2021	11:42:20 AM	50.09	412.9	417.6	416.2	0.6
1/30/2021	11:42:40 AM	50.07	412.2	417.4	415.7	0.6
1/30/2021	11:43:00 AM	50.06	412.3	417.2	415.7	0.6
1/30/2021	11:43:20 AM	50.06	411.7	417.2	415.3	0.7
1/30/2021	11:43:40 AM	50.06	411.1	417	414.8	0.8
1/30/2021	11:44:00 AM	50.04	410.8	417.4	414.9	0.8
1/30/2021	11:44:20 AM	50.03	410.7	417.3	415	0.8
Average Voltage & %Unbalance			414.8812379			0.68



Voltage Profile of 1000 kVA Transformer

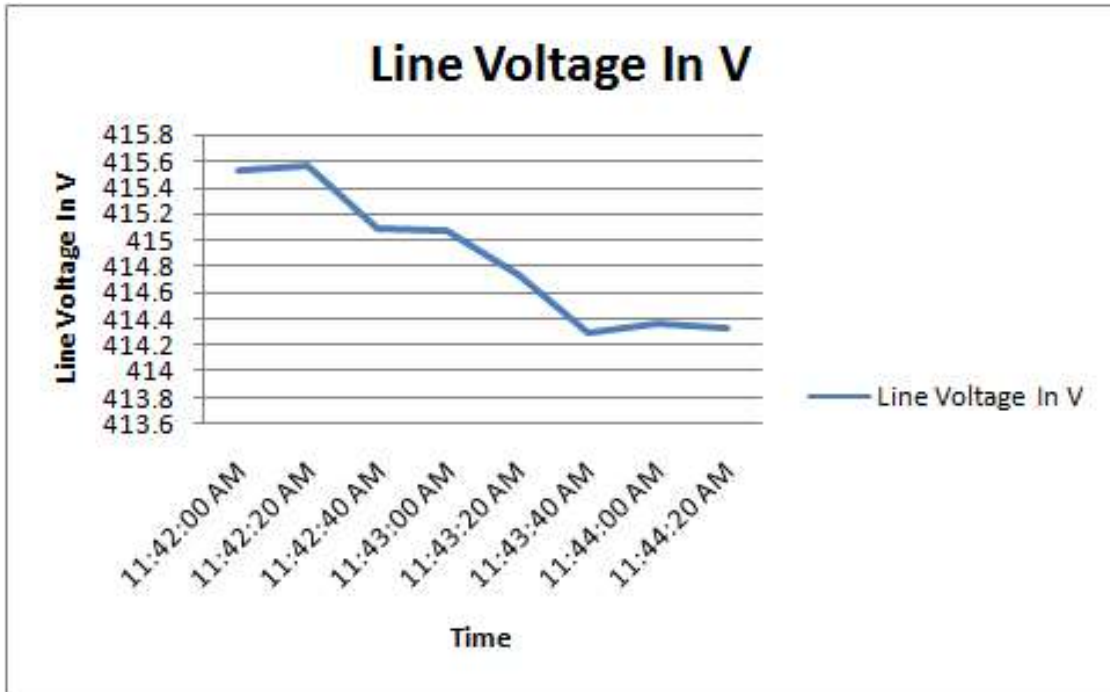

Current Variation and %Unbalance of 1000 kVA Transformer						
Date	Time	Frequency	A1 RMS	A2 RMS	A3 RMS	Aunb
		Hz	A	A	A	%
1/30/2021	11:42:00 AM	50.08	97.3	63.4	66.5	15.9
1/30/2021	11:42:20 AM	50.09	97.9	63	67	16.2
1/30/2021	11:42:40 AM	50.07	101.4	66.1	67.1	16.5
1/30/2021	11:43:00 AM	50.06	98.7	72.9	71	11.5
1/30/2021	11:43:20 AM	50.06	99.4	71.5	72	11.8
1/30/2021	11:43:40 AM	50.06	102.5	70.2	72.5	10.5
1/30/2021	11:44:00 AM	50.04	104.8	69.9	73	9.2
1/30/2021	11:44:20 AM	50.03	104.3	69.9	70.2	7.9
Average Current & %Unbalance			79.6875			12.4



Current Profile of 1000 kVA Transformer

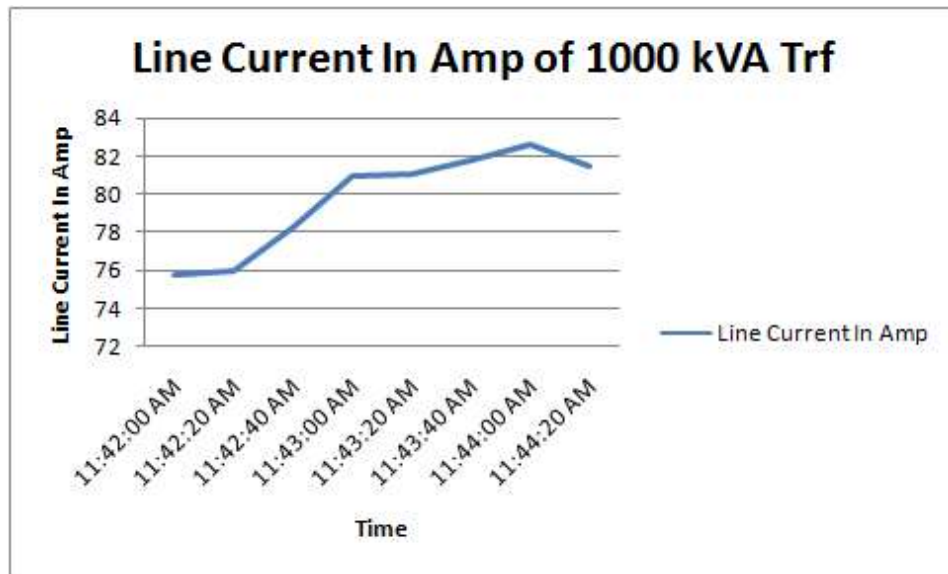

Average Power Factor of 1000 kVA Transformer						
Date	Time	Frequency	PF1	PF2	PF3	PF Mean
		Hz	Ph-1	Ph-2	Ph-3	Avg.
1/30/2021	11:42:00 AM	50.08	0.934	0.869	0.902	0.901
1/30/2021	11:42:20 AM	50.09	0.94	0.873	0.91	0.907
1/30/2021	11:42:40 AM	50.07	0.955	0.908	0.937	0.933
1/30/2021	11:43:00 AM	50.06	0.945	0.917	0.924	0.928
1/30/2021	11:43:20 AM	50.06	0.929	0.887	0.899	0.904
1/30/2021	11:43:40 AM	50.06	0.931	0.88	0.897	0.902
1/30/2021	11:44:00 AM	50.04	0.919	0.851	0.873	0.88
1/30/2021	11:44:20 AM	50.03	0.926	0.849	0.881	0.885
Average Power Factor						0.9



Power Factor Profile of 1000 kVA Transformer

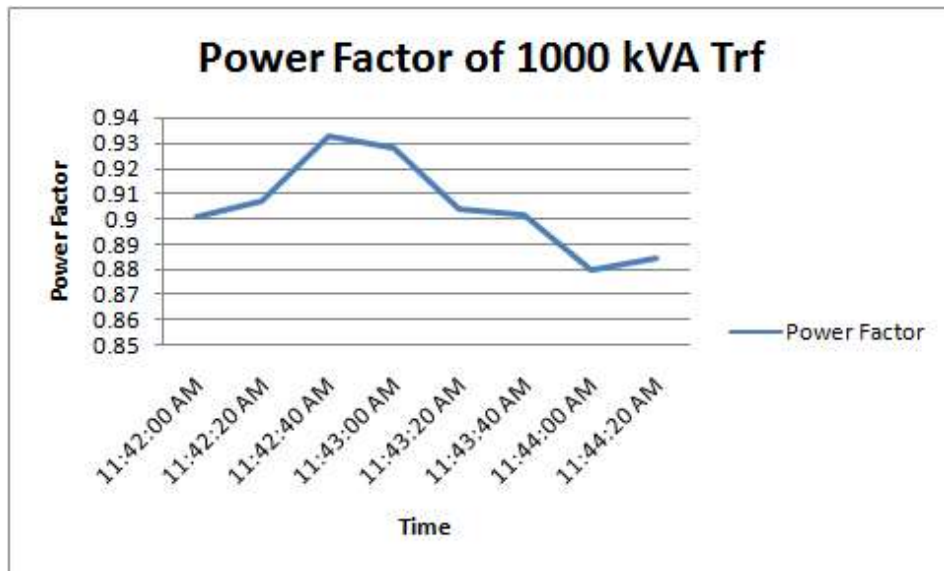

Snapshot of Load, var & VA of 1000 kVA Transformer					
Date	Time	Frequency	W Total	var Total	VA Total
		Hz	W	var	VA
1/30/2021	11:42:00 AM	50.08	49412.11	22600.36	54522.5
1/30/2021	11:42:20 AM	50.09	49926.29	21908.03	54704.7
1/30/2021	11:42:40 AM	50.07	52702.52	19350.03	56231
1/30/2021	11:43:00 AM	50.06	54149.3	21115.51	58167.1
1/30/2021	11:43:20 AM	50.06	52850.82	24006.6	58184.7
1/30/2021	11:43:40 AM	50.06	53156.86	24430.38	58651.1
1/30/2021	11:44:00 AM	50.04	52543.69	27127.1	59256.2
1/30/2021	11:44:20 AM	50.03	52103.82	26152.97	58455.3
Average			52105.68	23336.37	57271.58



Snapshot of Load, var & VA of 1000 kVA Transformer

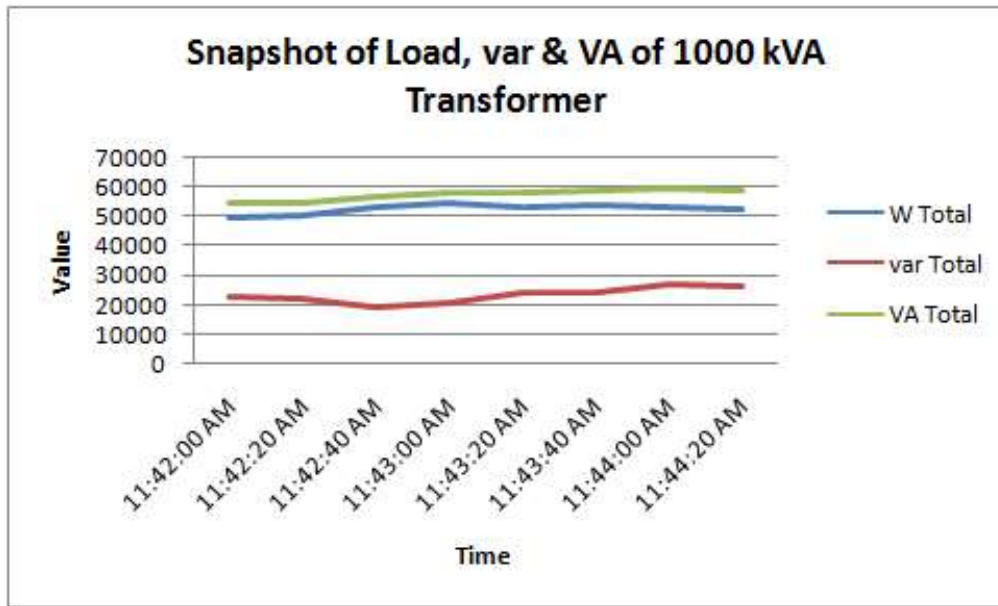

Voltage Variation and %Unbalance of 500 kVA Transformer						
Date	Time	Frequency	Phase-1 RMS	Phase-2 RMS	Phase-3 RMS	Vunb
		Hz	V	V	V	%
1/30/2021	12:00:00 PM	50.09	412.2	416	414.7	0.4
1/30/2021	12:00:20 PM	50.1	412.1	416.1	414.8	0.5
1/30/2021	12:00:40 PM	50.09	411.7	416.4	415.3	0.6
1/30/2021	12:01:00 PM	50.09	410.9	416.4	415.2	0.7
1/30/2021	12:01:20 PM	50.08	410.5	416.5	415.4	0.8
1/30/2021	12:01:40 PM	50.08	410.6	416.2	415.4	0.7
1/30/2021	12:02:00 PM	50.07	411.9	416.3	415.1	0.6
1/30/2021	12:02:20 PM	50.06	411.5	416	414.9	0.6
1/30/2021	12:02:40 PM	50.06	411.9	416.2	415	0.5
Average Voltage & %Unbalance			414.2716239			0.63



Voltage Profile of 500 kVA Transformer

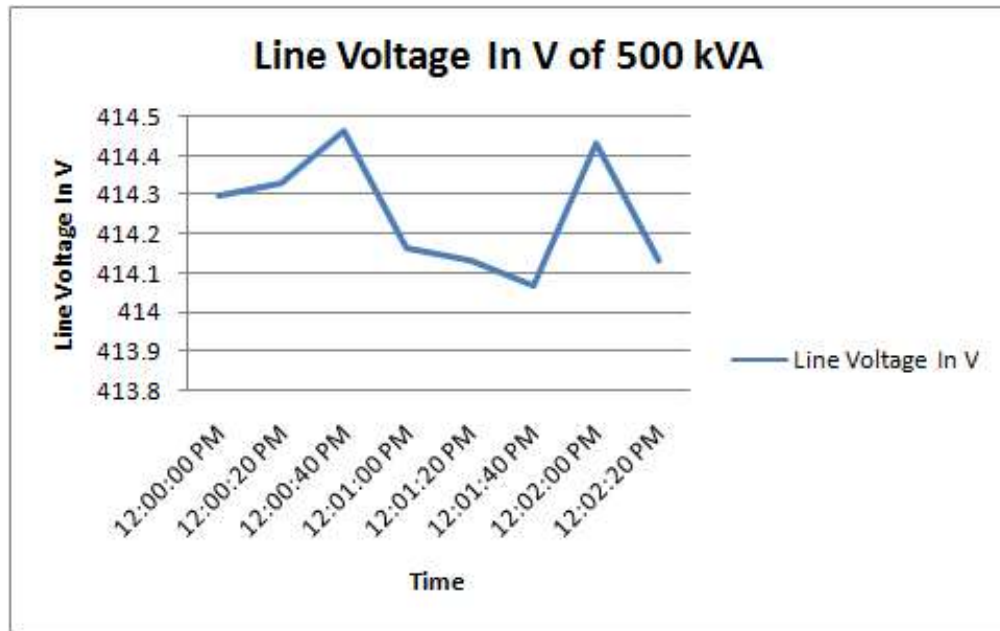

Current Variation and %Unbalance of 500 kVA Transformer						
Date	Time	Frequency	A1 RMS	A2 RMS	A3 RMS	Aunb
		Hz	A	A	A	%
1/30/2021	12:00:00 PM	50.09	267.7	208.8	248.1	3.7
1/30/2021	12:00:20 PM	50.1	266.3	204.3	238.6	3.9
1/30/2021	12:00:40 PM	50.09	262.5	194	232.1	4.9
1/30/2021	12:01:00 PM	50.09	263.7	192.8	235.1	5.3
1/30/2021	12:01:20 PM	50.08	273.4	190.5	237.5	7
1/30/2021	12:01:40 PM	50.08	268	201.9	235.3	4.5
1/30/2021	12:02:00 PM	50.07	269.6	188.6	228.5	6.3
1/30/2021	12:02:20 PM	50.06	272.5	191.2	230.9	6.2
1/30/2021	12:02:40 PM	50.06	269.7	193	228.9	5.7
Average Current & %Unbalance			233.0925926			5.2



Current Profile of 500 kVA Transformer

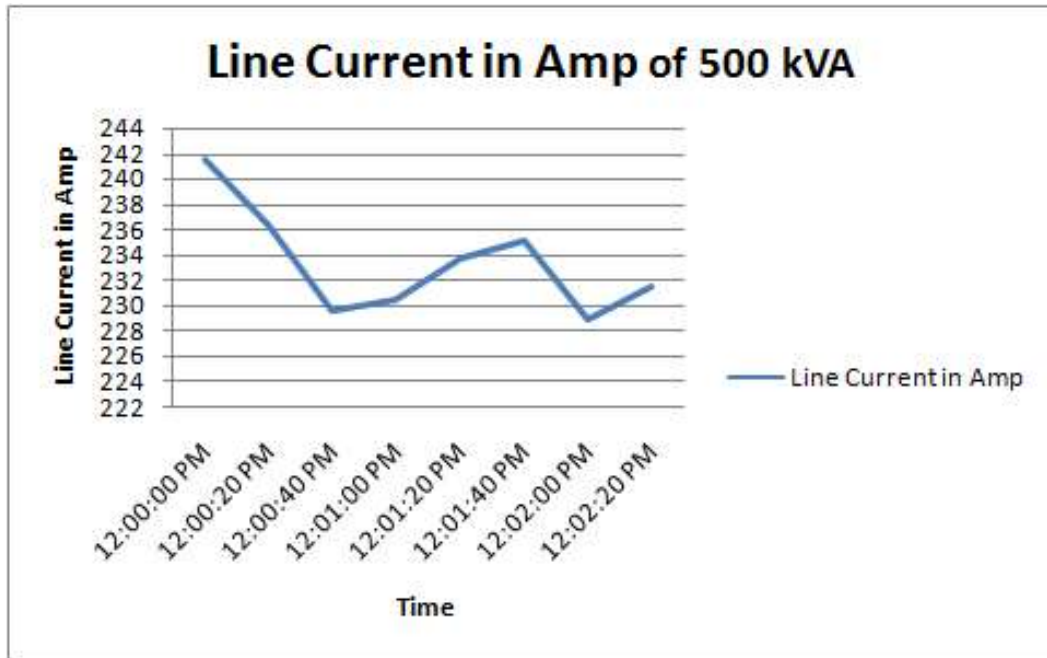

Average Power Factor of 500 kVA Transformer						
Date	Time	Frequency	PF1	PF2	PF3	PF Mean
		Hz	Ph-1	Ph-2	Ph-3	Avg.
1/30/2021	12:00:00 PM	50.09	0.99	0.99	0.98	0.987
1/30/2021	12:00:20 PM	50.1	0.99	0.99	0.98	0.988
1/30/2021	12:00:40 PM	50.09	0.99	1	0.98	0.989
1/30/2021	12:01:00 PM	50.09	0.99	1	0.98	0.989
1/30/2021	12:01:20 PM	50.08	0.99	0.99	0.98	0.985
1/30/2021	12:01:40 PM	50.08	0.99	0.99	0.97	0.986
1/30/2021	12:02:00 PM	50.07	0.99	0.99	0.98	0.987
1/30/2021	12:02:20 PM	50.06	0.99	0.99	0.98	0.987
1/30/2021	12:02:40 PM	50.06	0.99	1	0.98	0.989
Average Power Factor						0.987



Power Factor Profile of 500 kVA Transformer

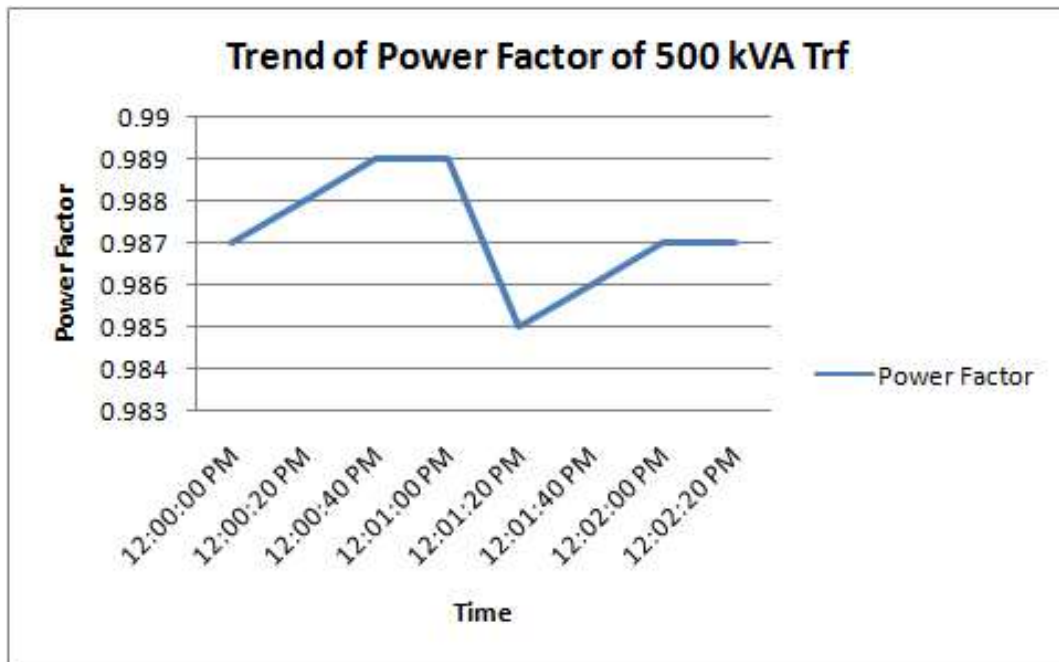

4.0. LIGHTING SYSTEM

LIGHTING INVENTORY

Adequate and proper lighting contributes both directly and indirectly towards productivity and safety, and towards providing an improved work atmosphere. In fact, all these are inter-related and complimentary to each other. There are several factors, which contribute towards proper lighting. However, all efforts were made to study and include these factors during audit of CUTM for lighting loads.

To study, analyze and identify energy conservation options in lighting, a study of the building lighting load was conducted. The purpose of the study was to determine the lighting load and its distribution in various sections of the Building, determine the quality of illumination provided, and recommend measures to improve illumination and reduce electricity consumption.

A high quality and accurate digital lux meter was used to measure the illumination level at various sections of the building during working hours. Other performance indicators such as type of lamps used, type of luminaries, physical condition of lamps and luminaries, use of day lighting, etc. was also noted down.

During the study, measurement of lighting loads, voltage conditions, phase balancing in the facility areas were carried out. The illumination level was also measured primarily at various classrooms and common areas of the building. Care was taken to reduce the effect of day lighting while taking the measurements. The recorded inventory is enclosed in tabular form.



To determine the quantity of lighting load a physical count of the light fittings in CUTM was carried out. Further, the inputs from the officials and maintenance log books were taken into consideration for calculating the inventory of total light fittings of the CUTM. The total connected load of lighting in CUTM is about 120.21KW. The summarized lighting installations are furnished below.

Table 4.1: Total individual lighting calculation of CUTM

Lighting Inventory				
Area Name	Types of Load	Wattage of each load in Watt	Nos. installed	Total connected Wattage in Watt
Boy's Hostel	LED	9	257	2313
	LED	20	486	9720
	LED	40	64	2560
	LED	85	16	1360
	LED Tube	20	264	5280
	LED Tube	40	125	5000
	LED Tube	50	27	1350
	LED Tube	60	243	14580
	LED Tube	70	6	420
	LED Tube	80	119	9520
	LED Tube	100	69	6900
	LED Tube	160	24	3840
	LED Tube	180	27	4860
	LED Tube	200	10	2000
	Tube	120	6	720
	Tube	160	8	1280
Girl's Hostel	LED Tube	160	24	3840
	Tube	160	8	1280
MBA	LED	20	2	40
	LED	25	2	50
	LED Tube Light	40	123	4920
	LED Tube Light	25	71	1775
Main Building	LED	9	2	18
	LED Tube Light	20	75	1500
	C.LIGHT	20	25	500
	C.LIGHT	60	228	13680
	Tube Light	40	430	17200



Madhusudan Building	LED Tube light	18	206	3708
	Siling light	30	215	6450
	Fluorescent Tube light	40	348	13920
	Small Led	9	64	576
Other Units	LED	10	69	690
	LED	20	8	160
	LED	36	178	6408
	LED	100	1	100
	Tube Light	40	322	12880
	Halogen Light	50	10	500
	CFL	150	6	900
Total		1991	2947	120214

4.1. O & M PRACTICE, ENERGY ACCOUNTING AND MONITORING FOR LIGHTING SYSTEM

CUTM electrical maintenance team looks after the operation & maintenance of electric supply, ventilation & air conditioning, lighting system etc. The works involves maintenance of Lighting system, Light replacement, Switching on/off of street light. Solar street light system installed and maintained by CUTM engineers. But now days the Timer are and the electricians are switching on/off the street lighting by manually. It is recommended to install Timer in the Street Light Circuit.

It is observed that there is no proper document available for keeping the records of lighting maintenance, lux survey, lighting inventory list, area wise lighting consumption etc. A set of well designed format for lighting system record keeping may be developed and maintained at the earliest.

Proper lighting inventory list to be maintained, further during any replacement of lighting system, same may be simultaneously updated in the inventory.

The Monitoring and Targeting programs have been so effective that they show typical reductions in annual energy costs between 5% and 20%.

The essential elements of M&T system are

- Recording: Measuring and recording energy consumption.
- Analyzing: Correlating energy consumption to actual energy consumption
- Comparing:-Comparing energy consumption to an appropriate standard or benchmark.
- Setting Targets: Setting targets to reduce or control energy consumption.
- Monitoring: Comparing energy consumption to the set target on a regular basis.
- Reporting: Reporting the results including any variances from the targets which have been set.
- Controlling:-Implementing management measures to correct any variances, which may have occurred.

4.2. ILLUMINATION SURVEY AND LUX LEVEL MEASUREMENT

The Illumination survey and Electrical Equipment Inventory List of the CUTM Building including Corridor was carried out by measuring the Lux of the different area, Chemistry Lab, office



chambers, Smart class room(R-218) and Class Room (R-219) using Lux meter, by physical counting of inventory and the results are tabulated below.

Lux Measurement		
Area	Measured Lux	Recommended Lux
Chemistry Lab	65,89,55,73,88	200-300-500
office chambers	82,85,71,76,180	50-100-150
Smart class room(R-218)	20,40,82,90,92,85	200-300-500
Class Room (R-219)	70,91,77,83,86,79	200-300-500

Sample Calculation of ILER

$$\text{Installed Load Efficacy Ratio (ILER)} = \frac{\text{Actual, lux/W/M}^2}{\text{Target, lux/W/M}^2}$$

Step-1	Measure the floor area of the interior:	Area in m ²
Step-2	Calculate the Room Index	RI
Step-3	Determine the total circuit watts of the installation by a power meter if a separate feeder for lighting is available. If the actual value is not known a reasonable approximation can be obtained by totaling up the lamp wattages including the ballasts:	Total circuit watts
Step-4	Calculate Watts per square meter, Value of step 3 ÷ value of step 1	W/m ²
Step-5	Ascertain the average maintained luminance by using lux meter, Eav. Maintained	Eav.maint.
Step-6	Divide 5 by 4 to calculate lux per watt per square Meter	Lux/W/m ²
Step-7	Obtain target Lux/W/m ² lux for type of the type of interior/application and RI (2):	Target Lux/W/m ²
Step-8	Calculate Installed Load Efficacy Ratio (6 ÷ 7).	ILER



Considering classroom number of 217, 218, chemistry Lab and Admin Room,

Step-1: Calculation of Room Area

Room Length in Meter=6.1m
Room Width in Meter=5.1m
Room Height in Meter=3.5m
Room Area in Sq. Meter= 6.1x5.1= 31.11 M²

Step-2: Calculation of Room Index (RI)

$$\text{Room Index (RI)} = \frac{L \times W}{H_m \times (L+W)}$$

H_m= Mounting Height which is the height of the lighting fittings above the horizontal working plane, L= Length of Room, W= Width of Room

$$H_m = 3.5 - 0.9 = 2.6 \text{ Meter}$$

$$\text{Room Index} = 31.11 / (3.5 - 0.9) \times 31.11 = 1.07$$

Step-3: Total Wattage of Light Fittings

Total wattage of light fittings of Dhauri Suite Bed Room= 12 W x 8 = 84 Watt

Step-4: Calculate Watts/ M²

$$W / M^2 = 84 / 31.11 = 2.7$$

Step-5: Average Lux level of Room

At the time audit Period the lux was measured at Lux meter = 58

Step-6: Calculate Lux/Watts/ M²

$$\text{Lux/Watts/ M}^2 = 58 / 2.7 = 21.48$$

Step-7: Obtain Targeted Lux/Watts/ M²



Target lux/W/m² (W/m²/100lux) values for maintained illuminance on horizontal plane for all room indices and applications			
Room Index	Commercial Lighting) Offices, Retail stores, etc.) & very clean industrial applications, Standard or good color rendering. Ra:40-85	Industrial lighting (Manufacturing areas, workshops, warehousing etc.) Standard or good color rendering. Ra:40-85	Industrial lighting installations where standard or good color rendering is not essential but some color discrimination is required. Ra: 20-40
5	53 (1.89)	49 (2.04)	67 (1.49)
4	52 (1.92)	48 (2.08)	66 (1.52)
3	50 (2.00)	46 (2.17)	65 (1.54)
2.5	48 (2.08)	44 (2.27)	64 (1.56)
2	46 (2.17)	42 (2.38)	61 (1.64)
1.5	43 (2.33)	39 (2.56)	58 (1.72)
1.25	40 (2.50)	36 (2.78)	55 (1.82)
1	36 (2.78)	33 (3.03)	52 (1.92)

Ra: Color rendering index

From the above BEE guideline table targeted Lux/Watts/ M² = 40

Ref: Guide Book for National Certification Examination for Energy Managers and Energy Auditors-Book 4

Step-8: Calculation of Installed Load Efficacy Ratio (ILER)

$$ILER = \frac{\text{Lux/Watts/ M}^2}{\text{Target Lux/Watt/M}^2} = \frac{21.48}{40} = 0.53$$

As per BEE Guidelines if ILER is less than 0.5 urgent actions are required.

INDICATORS OF PERFORMANCE	
ILER	Assessment
0.75 or Over	Satisfactory or Good
0.51 - 0.74	Review Suggested
0.5 or Less	Urgent action Required

Here ILER = 0.53, so here review suggested.



Annual energy Wastage (kWh/annum)= (1-ILER) x (watts/1000) x operating hours per annum

$$\begin{aligned} &= (1-0.53) \times (84/1000) \times (12 \times 300) \\ &= 142.12 \text{ kWh/annum} \end{aligned}$$

4.3. ENERGY CONSERVATION OPTION

It is observed in some locations like Reception Area etc. the light fittings are found switched on even if it is not required. These should be switched off during the non working hours and day time.

It was observed that LUX level of street lights at different location are between 5-8 which is not satisfactory. Since there is less occupancy & less movement in the street light area during night time, so the low LUX level is not causing any difficulties

It is suggested to adopt the following energy conservation measure in the street lights. It is observed that there is a mix of 40 W, 60W and 70W LED installed in the Building. As LUX level required is around of 22 lumens, it is suggested to replace 20 W LED Tube lights with 60W LED fittings, due to which there will be wattage per lamp savings and standardisation of inventory can be ensured. The periodic checking of load unbalances should be carried out so as to limit the unbalance less than 10%.

We could not find any timer for switching on / off of the street light, it is being carried out manually. The timer installation and setting and operation in the street light and area lights need to be ensured all the times in different seasons so as conserve energy in lighting circuit and increase productivity of the electrician.

It is suggested to conduct periodic Lux level survey (preferably once in 3 months) and maintain record properly. Necessary corrective actions should be taken periodically.

Awareness among staff, student and control room operators is to be created for improvement in all aspects of energy conservation especially relating to lighting in their respective wings.

4.4. ENCON OPTION IN LIGHTING SYSTEM

Advantage of LED

LEDs are ideal for use in applications that are subjects to frequent on-off cycling, unlike fluorescent lamps that burn out more quickly when cycled frequently, or HID lamps that require a long time before restarting. LEDs can very easily be dimmed or strobe. These light up very quickly. A typical red indicator LED achieves full brightness in microseconds. These do not contain mercury, unlike compact fluorescent lamps.



4.5. ELECTRICAL LOAD DISTRIBUTION

In CUTM apart from lighting load there are different types of electrical load likes fans, Computers, Printers, TVs, Geysers, Fridge and other home appliance etc. The summary of connected electrical load is furnished below.

Table- 4.2 Details of Other Connected Electrical Load

Load Centre	Kilo Watt
Lighting	120
Fans	488
AC System	466
Other Load	96
TOTAL	1170

UPS & Ventilation

At the time of audit period it is observed that there is no measure power consuming UPS system in CUTM.

Energy saving Opportunity:

It is recommended to keep the monitors of the computers in standby mode rather in screen saver mode to reduce the power consumption of the computers when not in use. It is difficult to quantify the saving on account of this measure. The investment will be zero and simple payback period will be immediate.

ENCON Option by replacement of Kitchens Geysers with solar Water Heater

The Geysers in kitchens can be replaced with solar water heater and a savings can be achieved.

4.6. ENCON OPTION FOR INSTALLATION OF SOLAR POWER PLANT IN NET METERING CONCEPT

Concept of Net Metering:

Net metering is the concept which records net energy between export of generated energy and import of DISCOM energy for a billing month. Alternatively, the meter, having the feature of recording both the import and export values, also are generally allowed for arriving net energy for the billing period.

Principle of Net metering:

Based on available roof area / ground area solar PV panels will be installed. The output of the panels (DC electricity) will be connected to the power conditioning unit / inverter which converts DC to AC. The inverter output will be connected to the control panel or distribution board of the



building to utilise the power. The inverter synchronises with grid and also with any backup power source to produce smooth power to power the loads with preference of consuming solar power first. If the solar power is more than the load requirement, the excess power is automatically fed to the grid. For larger capacity systems connection through step up transformer and switch yard will be used to feed the power to grid.

Advantages of Net metering:

The grid connected roof top / ground mounted solar PV system would fulfill the partial / full power needs of large scale buildings. The following are some of the benefits of roof top SPV systems:

- Generation of environmentally clean energy
- Consumer becomes generator for his own electricity requirements
- Reduction in electricity consumption from the grid
- Reduction in diesel consumption wherever DG backup is provided
- Feeding excess power to the grid

Implementation:

1. The total project cost to be borne by the consumer, however consumer is eligible for any subsidy / grant from State Govt./ Central Govt. / MNRE as applicable from time to time Implementation of net metering facility shall be made applicable for the consumers having 3-phase supply service connection.
2. Protection system including its switch gear to be certified by concerned Ex. Engineer and harmonic suppressive device to be installed by such SPV generator to suppress the harmonics injection as harmonics is more in case of solar plants where conversion of DC to AC is taking place. Islanding protection requirements to be provided.
3. The SPV generator shall provide the indication of solar PV plant at the injection point for easy identification to the operating personnel.
4. The SPV generator needs to get statutory approvals from appropriate authority like Electrical Inspector for the connected equipment including its solar panels.
5. The proposed generator shall submit the prescribed application to the concerned Executive Engineer of local DISCOM who should be nodal authority for approval of the same.
5. The net meter / meter to be used for arriving net energy shall have the specifications prescribed.
6. Concerned JE of DISCOM shall issue a technical feasibility certificate and witness the synchronization of SPV plant with distribution network.
7. 0.5 class accuracy, tri-vector based energy meter, non ABT having the MRI downloading facility along with related accessories shall have to be installed by the SPV generator as per the specifications of DISCOM.
8. Spot billing is to be arranged by concerned DISCOM as per the billing period. DISCOM shall arrange to develop suitable software and incorporate in the billing instrument for such billing.

It is recommended to install 44 kW Solar Project in ITOT Building, 195 kW in CSREM Building and 68 kW in ITI Building, total 307 kW Solar rooftop Project is recommended.



5.0. HVAC SYSTEM

At present, the air conditioning system in the CUTM is met through window /split AC of following number.

There is around 233 numbers air conditioning system in CUTM

It is estimated that there is about 365 KW of AC load in CUTM contributing to about 40% of the total connected load.

Installed Air conditioning System of CUTM are furnished below.

Detail Inventory of ACs of CUTM				
Type of Load	Watt	Rated Tonnage	Number	Tonnage
Air-conditioner	750	0.5	1	0.5
	1000	1	5	5
	1500	1.5	213	319.5
	2000	2	10	20
	3500	5	4	20
Total	25125		233	365

Advantages of Inverter Air Conditioner

The latest and the most efficient technology that is available in market today is the Inverter Technology for air conditioners. Inverter technology is designed in such a way that it can save 30-50% of electricity (units consumed) over a regular air conditioner.

Inverter air conditioners are more powerful, offer great savings and are better at maintaining temperature compared to non-inverter air conditioners. When compressor needs more power, it gives it more power. When it needs less power, it gives less power. With this technology, the compressor is always on, but draws less power or more power depending on the temperature of the incoming air and the level set in the thermostat. The speed and power of the compressor is adjusted appropriately.

Let's take an example of 1.5 Ton inverter air conditioner versus non-inverter air conditioner

A 1.5 Ton inverter air conditioner works initially at 1.7 Ton and as the desired temperature is achieved it reduces its capacity to 1.5, 1 or .3 Ton based on room conditions.

A 1.5 Ton non-inverter air conditioner on the other hand works at 1.5 Ton all the times.

Every air conditioner is designed for a maximum peak load. So a 1.5ton AC is designed for a certain size of room and 1 ton for a different size. But not all rooms are of same size. A regular air conditioner of 1.5ton capacity will always run at peak power requirement when the compressor is running. An air conditioner with inverter technology will run continuously but will draw only that much power that is required to keep the temperature stable at the level desired. So it automatically adjusts its capacity based on the requirement of the room it is cooling. Thus drawing much less power and consuming lesser units of electricity.



5.1. MAINTENANCE TIPS FOR SPLIT / WINDOW AC

- Make sure your AC doesn't get overloaded; check the fuse or circuit breaker if it doesn't operate.
- Remember to replace or clean the filter and have your mechanic clean the evaporator and condenser coils regularly, for the air conditioner to cool your home efficiently.
- Install a programmable thermostat, it will lead to 10-15% energy saving.
- Set your thermostat as high as possible comfortable.
- Set the fan speed on high except on very humid days, when humidity is high set the fan speed on low for more comfort.
- Install units in shade, it will lead to 10% saving in energy consumption.
- Use sun films on windows. That will cut heat entry by 70% of the building.
- If the AC makes noise it needs to be checked by the mechanic
- Giving your air conditioning system a good electrostatic air filter is the best thing you can do for your air conditioner. A good air filter will extend the life of your air conditioner because the important parts, like the cooling coil, and other inner parts will stay cleaner, operate more efficiently and last longer.
- Avoid frequent opening of doors/windows. A door kept open can result in doubling the power consumption of your AC.
- Ensure direct sunlight (and heat) do not enter the air-conditioned space, particularly in the afternoons.
- Most people believe that a thermostat set to a lower temperature than desired, will force your air-conditioner to cool faster, not really, all it does, is make your air-conditioner operate for longer. Moreover, you will have an unnecessarily chilly room and wasted power. Every degree lower on the temperature setting results in an extra 3-4% of power consumed. Hence, once you've found yourself a comfortable temperature and set the thermostat at that level, avoid touching the thermostat thereafter.
- Once an air-conditioning system has been designed and installed avoid any major change in the heat-load on the AC. This will add to wasted power.
- Always ensure that whenever you install new unit, make sure its EER ($12/(kW/TR)$) should be between 9.5 to 10.5.
- No gap should be left during installing units for cool air escape.

6.0. DIESEL GENERATING (DG) SET

Observation & Analysis for DG Set:

- There are two nos. of DG sets of 125 KVA capacity and 25 KVA capacity installed in CUTM to meet the power requirement of the major areas of the building in case of power supply failure from TPCODL.
- The technical specification of the DG Set is furnished below:



Table- 6.1. Technical specification of the DG set

Technical Specification of DG			
Particulars	DG Set 1	DG Set 2	DG Set 3
Name of DG Set	KOEL	KOEL	Koel Green
Capacity in kVA	200	400	500
Phase	3	3	3
Rated Voltage in Volt	415	415	415
Rated Current in Amp	278.2	556.5	695.56
Rated PF	0.8	0.8	0.8
Rated Speed in RPM	1500	1500	1500
Rated Fuel Consumed in Litre/Hour	34.4	46	107.5

Data Sheet of 200kVA DG Set for FY 2017-18	
Month	Diesel Consumption in kL
Apr-17	0.934
May-17	0.801
Jun-17	0.597
Jul-17	1.067
Aug-17	1.561
Sep-17	0.739
Oct-17	1.214
Nov-17	0.364
Dec-17	1.651
Jan-18	0.718
Feb-18	1.034
Mar-18	0.871
Total	11.550



Data Sheet of 400kVA DG Set for FY 2017-18	
Month	Diesel Consumption in kL
Apr-17	3.234
May-17	2.303
Jun-17	2.626
Jul-17	4.099
Aug-17	5.766
Sep-17	2.660
Oct-17	2.940
Nov-17	2.813
Dec-17	3.054
Jan-18	3.544
Feb-18	2.509
Mar-18	2.941
Total	38.489

Data Sheet of 500kVA DG Set for FY 2017-18	
Month	Diesel Consumption in kL
Apr-17	NA
May-17	NA
Jun-17	NA
Jul-17	NA
Aug-17	NA
Sep-17	NA
Oct-17	NA
Nov-17	NA
Dec-17	NA
Jan-18	NA
Feb-18	NA
Mar-18	0.152
Total	0.152



Data Sheet of 200kVA DG Set for FY 2018-19	
Month	Diesel Consumption in kL
Apr-18	0.637
May-18	1.065
Jun-18	0.456
Jul-18	0.784
Aug-18	0.617
Sep-18	14.312
Oct-18	0.285
Nov-18	NA
Dec-18	NA
Jan-19	NA
Feb-19	NA
Mar-19	NA
Total	18.157

Energy Data Sheet of 400kVA DG Set for FY 2018-19	
Month	Diesel Consumption in kL
Apr-18	3.496
May-18	4.440
Jun-18	2.139
Jul-18	2.488
Aug-18	3.296
Sep-18	1.917
Oct-18	1.333
Nov-18	0.328
Dec-18	0.380
Jan-19	0.260
Feb-19	0.533
Mar-19	0.611
Total	21.222



Energy Data Sheet of 500kVA DG Set for FY 2018-19	
Month	Diesel Consumption in kL
Apr-18	NA
May-18	0.953
Jun-18	NA
Jul-18	2.026
Aug-18	1.305
Sep-18	1.463
Oct-18	0.825
Nov-18	0.068
Dec-18	0.336
Jan-19	0.265
Feb-19	0.648
Mar-19	0.355
Total	8.243

Energy Data Sheet of 200kVA DG Set for FY 2019-20	
Month	Diesel Consumption in KL
Apr-19	0.400
May-19	1.777
Jun-19	0.231
Jul-19	1.866
Aug-19	0.704
Sep-19	NA
Oct-19	0.240
Nov-19	0.115
Dec-19	0.063
Jan-20	0.134
Feb-20	0.102
Mar-20	0.110
Total	5.742



Energy Data Sheet of 400kVA DG Set for FY 2019-20	
Month	Diesel Consumption in KL
Apr-19	1.210
May-19	9.892
Jun-19	0.961
Jul-19	0.503
Aug-19	NA
Sep-19	NA
Oct-19	NA
Nov-19	NA
Dec-19	0.145
Jan-20	0.376
Feb-20	0.009
Mar-20	0.353
Total	13.449

Energy Data Sheet of 500kVA DG Set for FY 2019-20	
Month	Diesel Consumption in KL
Apr-19	0.495
May-19	8.962
Jun-19	2.945
Jul-19	10.429
Aug-19	3.959
Sep-19	5.740
Oct-19	1.921
Nov-19	0.473
Dec-19	0.785
Jan-20	0.576
Feb-20	0.402
Mar-20	0.954
Total	37.642



Recommendation:

- The DG sets are normally operated in power failure condition and in any emergency load requirement case.
- The details of energy generated and consumption of Diesel for both the DG set is not being recorded presently for which the specific energy consumption of DG set could not be evaluated.
- So it is recommended that the DG set generation and HSD consumption details are be noted monthly basis in log book for future reference and evaluation of SEC.
- Both the DG set should be inspected by Electrical Inspector, Energy Meter should be installed across the DG set and sealed properly in consultation with Chief Electrical Inspector.
- The record of energy generated in DG set is not available. It is to be recommended that energy meter is to be installed in each DG set and the energy generated in each DG set has to be recorded to calculate the specific energy consumption of DG set.

7.0. WATER PUMPING SYSTEMS

7.1. WATER PUMPING STORAGE AND DISTRIBUTION SYSTEM

CUTM meets its water requirement from the PHD Department from the nearby water storage facility, the pump house is having different electrical connection and not linked with CUTM Power distribution system, it only supplies required portable water to CUTM.

Utilization of water Pumping System

There are submersible types of pumps installed in CUTM for the auxiliary consumption of water like housekeeping, gardening etc. There are 12 nos. of 3 HP submersible pump, 5nos. of 2 HP pumps.

Mechanical Power Transmission Study and Rational Usages of Drives

There are submersible types of pumps installed in CUTM for the auxiliary consumption of water like housekeeping, gardening etc. Though these are submersible type pump, hence the study mechanical power system could not be carried out and hence no recommendation is furnished for the same. It is recommended that in future flow meter to be installed and water consumption to be monitored.

**8.0. FINANCIAL ANALYSIS OF THE IMPLEMENTED ENERGY CONSERVATION PROJECT**

DETAILS OF ENERGY EFFICIENCY IMPROVEMENT MEASURES IMPLEMENTED, UNDER IMPLEMENTATION, INVESTMENT MADE, SAVINGS IN ENERGY ACHIEVED AND THE PROGRESS MADE IN THE IMPLEMENTATION OF OTHER RECOMMENDATIONS									
A. Implemented:									
Sl. No.	Details of energy efficiency improvement measure	Category	Investment in Rs.	Verified Savings in Rs	Verified Energy Savings	Units	Fuel	Equivalent Verified Energy Savings in TOE	Remarks
1	Optimization of lighting load by operating 8 hour (Ceiling light & Ceiling light ring type fitting)	Lighting	Nil	13648080	37392	kWh		3.216	
2	Optimization of lighting load by operating 12 hour (Street light & LED tube light type fitting)	Lighting	Nil	18658800	51120	kWh		4.396	
Total			Nil	32306880	88512	kWh		7.61203	

9.0. OPERATION AND MAINTENANCE OF CUTM

CUTM Electrical Maintenance looks after the operation & maintenance of electric supply, ventilation & air conditioning, lighting system etc. of the entire building to ensure proper work environment and comfort of its residents and officials. There are 10 nos. of technicians and one Junior Engineer in CUTM Electrical. The works involves maintenance of lift, AC, motor, normal Fuse call Attending, Light replacement, Switching on/off of street light. Earlier Timer was installed in street light system. But now days the Timer are not functioning and the electricians are switching on/off the street lighting by manually. It is recommended to install Timer in the Street Light Circuit.

10.0. ENERGY MONITORING & ACCOUNTING SYSTEM

Energy monitoring and targeting (M & T) is primarily a management technique that uses energy information as a basis to eliminate waste, reduce and control current level of energy use and improve the existing operating procedures. It builds on the principle "you can't manage what you don't measure". It essentially combines the principles of energy use and statistics.

While, monitoring is essentially aimed at establishing the existing pattern of energy consumption, targeting is the identification of energy consumption level which is desirable as a management goal to work towards energy conservation.

Monitoring and Targeting is a management technique in which all plant and building utilities such as fuel, refrigeration, water, effluent, and electricity are managed as controllable resources in the same way that inventory, building occupancy, personnel and capital are managed. It involves a systematic, disciplined division of the facility into Energy Cost Centers. The utilities used in each centre are closely monitored. Once this information is available on a regular basis, targets can be set, variances can be spotted and interpreted, and remedial actions can be taken and implemented.



The Monitoring and Targeting programs have been so effective that they show typical reductions in annual energy costs in various industrial sectors between 5 and 20%.

The essential elements of M&T system are:

- Recording: Measuring and recording energy consumption.
- Analyzing: Correlating energy consumption to actual energy consumption
- Comparing:-Comparing energy consumption to an appropriate standard or benchmark.
- Setting Targets: Setting targets to reduce or control energy consumption.
- Monitoring: Comparing energy consumption to the set target on a regular basis.
- Reporting: Reporting the results including any variances from the targets which have been set.
- Controlling:-Implementing management measures to correct any variances, which may have occurred.

The energy used by any business varies with production processes, volumes and input. Determining the relationship of energy use to key performance indicators will allow the Building owner to determine:

- Whether the current energy is better or worse than before
- Trends in energy consumption that reflects seasonal, weekly, and other operational parameters
- How the future energy use is likely to vary Specific areas of wasted energy
- Comparison with other business with similar characteristics - This “benchmarking” process will provide valuable indications

The CUTM Electrical Maintenance looks after the operation and maintenance of the utilities. The Shift Technician maintains only the daily complain register. However it is proposed that department should maintain and update the log book for transformer electrical parameter measurement, Diesel Consumption, DG set Energy Generation, list of inventory like LED light, fan, AC, Equipment etc.

The House hold office should also maintain the detailed Energy Bill Analysis in Excel file in its Computer for reference and review purposes. The Energy Bill copy should be kept serially in files.

Electrical Safety:

It is observed that the Single Line Diagram (SLD) of the entire electrical system is to be displayed at concerned places. This will help in identifying the fault easily and doing the maintenance job more effectively. The SLD should be reviewed once in year to put necessary changes.

At Panel rooms, the following points are suggested as per safety & electricity rules.

- Rubber mats should be placed on the floor around the PDB panels in each switch room.
- No panel door should be kept open in both sides.
- Proper bunching of cables should be ensured at each switch room. The cables should be clearly tagged at starting & ending points which would help for easy the identification of cables for fault finding & maintenance work.
- Danger plates should be displayed at concerned places.
- Proper naming of loads should be done on each panel.

Awareness and attitude of occupants toward energy efficiency:

It is suggested to create energy conservation awareness among the staff by observing Energy Conservation Day, encouraging & recognizing energy conservation efforts made by any individual



or groups. A core committee on Energy Conservation, Electrical Safety, Resource conservation may also be formed to review the related activities.

11.0. TECHNICAL SPECIFICATIONS FOR ENERGY EFFICIENT PRODUCT

1. Capacitor Bank

Standard parameter	Value/Feature
Total rating of capacitors	60 kVAr
Rated AC Voltage	440Volt
Frequency	50 HZ
No. of Phases	3 phase
Standard	IS 13340-1993
APFC relay	Microprocessor Based
Losses	< 0.2 W/kVAr

2. Lighting

Standard Parameter	Feature
Voltage	220 - 240 V
Shape	Bulb
Lifetime of lamp	15000 hour(s)
Lumen maintenance factor	0.7
Average life (at 2.7 hrs/day)	15.2 year(s)
Number of switch cycles	50000
Rated luminous flux	1400 lm
Rated lifetime	15000 hour(s)
Rated beam angle	150 degree
Light output	1400 lumen
Beam angle	150 degree
Colour temperature	6500 K
Light effect/finish	Cool Daylight
Colour rendering index (CRI)	80
Starting time	<0.5 s
Warm-up time to 60% light	Instant full light
Colour	Cool Daylight

3. Air Conditioner

Standard Parameter	Feature
Window AC (1.5 Ton)	
Cooling Capacity (Watt)	5265
Max Power Consumption (Watt)	1847
Preferable BEE Star Rating	3
Energy Efficiency Ratio (EER)	2.85 W/W
Preferable Compressor Type	Rotary/reciprocating



Preferable Refrigerant Gas	R-22
Window AC (2 Ton)	
Cooling Capacity (Watt)	7020
Max Power Consumption (Watt)	2463
Preferable BEE Star Rating	3
Energy Efficiency Ratio (EER)	2.85 W/W
Preferable Compressor Type	Rotary/reciprocating
Preferable Refrigerant Gas	R-22
Split AC (1.5 Ton)	
Cooling Capacity (Watt)	5265
Max Power Consumption (Watt)	1815
Preferable BEE Star Rating	4
Energy Efficiency Ratio (EER)	2.90 W/W
Preferable Compressor Type	Rotary/reciprocating
Preferable Refrigerant Gas	R-22
Split AC (2 Ton)	
Cooling Capacity (Watt)	7020
Max Power Consumption (Watt)	2420
Preferable BEE Star Rating	4
Energy Efficiency Ratio (EER)	2.90 W/W
Preferable Compressor Type	Rotary/reciprocating
Preferable Refrigerant Gas	R-22

3. 100 LPD Solar Water Heater

Standard Parameter	Feature
Specification	S.S 0.8mm THICKNESS INNER TANK 47mm X 1500mm ETC GLASS TUBES
System Capacity in LPD	100
Nos. of Tubes	15

4. Energy Efficient Fan

Model Name	E1-1200
Reversible Rotation	No
Remote	Yes
Blade Material	Aluminum
Leaf	3

Weight (kg)	4
Dimensions	120 x 140 cm
Down rod Height	30.48 cm
Span (mm/inch)	1200/48
Rated Voltage *	140 - 285



Rated Frequency	48 - 52
Input Power (typical)	28
Power Factor (typical)	0.95
Air Delivery	230

STAR RATING PLAN IN ROOM AIR CONDITIONERS

New BEE Energy Efficiency Ratings (EER) for Room Air Conditioners					
STAR RATING LEVELS - Jan 1, 2014 - Dec 31, 2015					
EER (W/W)					
WINDOW AC			SPLIT AC		
Star Rating	Minimum	Maximum	Star Rating	Minimum	Maximum
1 Star ★	2.50	2.69	1 Star ★	2.70	2.89
2 Star ★★	2.70	2.89	2 Star ★★	2.90	3.09
3 Star ★★★	2.90	3.09	3 Star ★★★	3.10	3.29
4 Star ★★★★	3.10	3.29	4 Star ★★★★	3.30	3.49
5 Star ★★★★★	3.30	-	5 Star ★★★★★	3.50	-

STAR RATING PLAN IN DISTRIBUTION TRANSFORMERS

Rating	1 Star		2 Star		3 Star		4 Star		5 Star	
	Max Losses at 50% (Watts)	Max Losses at 100% (Watts)	Max Losses at 50% (Watts)	Max Losses at 100% (Watts)	Max Losses at 50% (Watts)	Max Losses at 100% (Watts)	Max Losses at 50% (Watts)	Max Losses at 100% (Watts)	Max Losses at 50% (Watts)	Max Losses at 100% (Watts)
kVA										
16	200	555	165	520	150	480	135	440	120	400
25	290	785	235	740	210	695	190	635	175	595
63	490	1415	430	1335	380	1250	340	1140	300	1050
100	700	2020	610	1910	520	1800	475	1650	435	1500
160	1000	2800	880	2550	770	2200	670	1950	570	1700
200	1130	3300	1010	3000	890	2700	780	2300	670	2100

STAR RATING PLAN IN PUMP SETS

Star Rating	Overall Efficiency of the Pump Set*
1 Star	>= 1.00 & < 1.05
2 Star	>= 1.05 & < 1.10
3 Star	>= 1.10 & < 1.15
4 Star	>= 1.15 & < 1.20
5 Star	>= 1.20



LIST OF ABBREVIATIONS

AC	:	Air Conditioning
BEE	:	Bureau of Energy Efficiency
CFL	:	Compact Fluorescents Lamp
LED	:	Light Emitting Diode
FTL	:	Fluorescents Tube Light
HPMV	:	High Pressure mercury
HPSV	:	High Pressure Sodium
CTR	:	CT Ratio
DB	:	Distribution Board
DG	:	Diesel Generator
ENCON	:	Energy Conservation
HRS	:	Hours
HT	:	High Tension
I	:	Current
KL	:	Kilo Litre
KV	:	Killo Volt
KVA	:	Killo Volt Ampere
KVAH	:	Kilo Volt Ampere Hour
KVAR	:	Killo Volt Ampere Reactive
KW	:	Killo Watt
KWH	:	Killo Watt Hour
THD	:	Total harmonic distortion
LT	:	Low Tension
PF	:	Power Factor
PTR	:	PT Ratio
SEC	:	Specific Energy Consumption
TF	:	Transformer
UF	:	Utilization Factor
V	:	Voltage



Investment Grade Energy Audit of CUTM, Paralakhemundi

INVESTMENT GRADE ENERGY AUDIT REPORT

of Centurion University of Technology & Management

Paralakhemundi, Gajapati, Odisha



Submitted to:

Centurion University of Technology & Management

At: Village Alluri Nagar, R Sitapur, Via- Uppalada, Paralakhemundi

Dist: Gajapati, Odisha- 761211

Tel +91 82600 77222

Website: www.cutm.ac.in



Power Tech

Consultants

Submitted by:

Power Tech Consultants

Corporate Office: K-8-82, Kalinga Nagar, Ghatikia

Bhubaneswar-751029, Odisha

Phone: 0674-2954256, Mob: 9937112760, 9437155337

Email: pwrtech@gmail.com

Website: www.pwrtech.com



Contents

List of Tables	3
LIST OF ABBREVIATIONS	4
ACKNOWLEDGEMENT	5
AUDIT TEAM DETAILS	6
CERTIFICATE	6
EXECUTIVE SUMMARY	7
1.0 INTRODUCTION	13
1.1. About The Site	14
1.2. Scope of Works	14
1.3. Methodology	16
1.4. Instruments Used	17
2.0 BRIEF DESCRIPTION OF THE UNIVERSITY	18
2.1 Major Utility	19
3.0 ENERGY SCENARIO	20
3.1 Analysis of Energy Bill	21
3.2 Base Line Energy Consumption and Specific Energy Consumption	27
3.3 Electrical Distribution System and Water Distribution System	38
3.4 Transformer Details	43
3.5 Study of Voltage, Current, Power Factor Profile	44
4.0 LIGHTING SYSTEM	63
4.1 Lighting Inventory	63
4.2 O & M Practice, Energy Accounting and Monitoring For Lighting System	66
4.3 Illumination Survey and Lux Level Measurement	67
4.4 Energy Conservation Option	67
4.5 Electrical Load Distribution	67
4.6 UPS & Ventilation	68
4.7 ENCON Option for Installation of Solar Water Heater	68
4.8 ENCON Option for Installation of Solar Power Plant in Net Metering Concept	69
5.0 HVAC System	71
5.1 Energy Conservation Option	72
5.2 Advantages of Inverter Air Conditioner	75
5.3 Maintenance Tips for Split / Window AC	75
6.0 Fan Inventory	76
6.1 Energy Conservation Option	78
7.0 DIESEL GENERATING (DG) SET	79



7.1	Observation & Analysis for DG Set	79
7.2	Recommendation	81
8.0	TRANSPORTATION	81
8.1	Energy Conservation Option	83
9.0	WATER PUMPING SYSTEMS	84
9.1	Water Pumping Storage and Distribution System	84
9.2	Utilization of water Pumping System	84
9.3	Mechanical Power Transmission Study and Rational Usages of Drives	84
9.4	Rain Water Harvesting System	85
9.5	Sewage Treatment Plant	85
10.0	WIND PLANT & BIOGAS PLANT	85
10.1	ENCON Option for Installation of 3 kW Wind Plant	85
10.2	Financial Benefit by Installation of Biogas Plant	86
11.0	FINANCIAL ANALYSIS OF PROPOSED ENERGY CONSERVATION PROJECT	87
11.1	Operation and Maintenance of CUTM	87
11.2	Energy Monitoring & Accounting System	88
12.0	TECHNICAL SPECIFICATIONS FOR ENERGY EFFICIENT PRODUCT	89
13.0	MOU Format with EESL	93
14.0	ENERGY MANAGEMENT POLICY	96
Annexure:		97
15.0	Vender Details of Projects	100

List of Tables

Table 1: Energy Fact File Of CUTM, Paralakhemundi	20
Table 2: Consumer Details Of The Building	21
Table 3: Summary Of Energy Bill Analysis Of CUTM, Paralakhemundi	21
Table 4: Energy Bill Of CUTM, Paralakhemundi For FY' 2020-21	23
Table 5: Energy Bill Of CUTM, Paralakhemundi For FY' 2021-22	24
Table 6: Cost Benefit Analysis	27
Table 7: Connected Load Details & Corresponding kW	28
Table 8: Detail Lighting Inventory Of All The Units Of CUTM, Paralakhemundi	28
Table 9: Detail Inventory Of ACs	31
Table 10: Detail Inventory Of All Types Of Fan	32
Table 11: Detail Inventory Of Other Appliances	34
Table 12: Technical Specification Of Transformer	43
Table 13: Transformer Performance Assessment	43
Table 14: Voltage Variation And % Unbalance Of Load Distribution	45
Table 27: Total Individual Lighting Calculation Of CUTM, Paralakhemundi	63
Table 28: Lux Measurement	67
Table 29: Details Of Total Connected Electrical Load	68



Table 30: Cost Benefit Analysis Of Installation Of Solar Water Heater	68
Table 31: Cost Benefit Analysis Of Establishment Of Solar Power Project In CUTM, Paralakhemundi.....	69
Table 32: Detail Inventory Of AcS Of CUTM, Paralakhemundi	71
Table 33: Cost Benefit Analysis Of Ac.....	72
Table 34: Eesl-Seac Boq (Voltas).....	72
Table 35: Fan Inventory.....	76
Table 36: Cost Benefit Analysis Of Fan.....	78
Table 37: Technical Specification Of The DG Set.....	79
Diesel Consumption Of 380 Kva Dg Set For 3 Year Is Furnished Bellow:	79
Table 38: Diesel Consumption Of 380 Kva Dg Set For FY 2018-19	79
Table 39: Diesel Consumption Of 380 Kva Dg Set For FY 2019-20	80
Table 40: Diesel Consumption Of 380 Kva Dg Set For FY 2020-21	80
Table 41: Vehicle Detail Of CUTM, Paralakhemundi.....	81
Table 42: Cost Benefit Analysis Of E-Rickshaw By Replacing Conventional Vehicle.....	83
Table 43: Cost Benefit Analysis By Installation Of 3 kW Wind Plant.....	86
Table 44: Cost Benefit Analysis By Installation Of Biogas Plant	86
Table 45: Financial Analysis Of Proposed Project	87

LIST OF ABBEREVIATIONS

AC	:	Air Conditioning
BEE	:	Bureau of Energy Efficiency
LED	:	Light Emitting Diode
CTR	:	CT Ratio
DB	:	Distribution Board
DG	:	Diesel Generator
ENCON	:	Energy Conservation
HRs	:	Hours
HT	:	High Tension
I	:	Current
kL	:	Kilo Liter
kV	:	Kilo Volt
KVA	:	Kilo Volt Ampere
kVAh	:	Kilo Volt Ampere Hour
kVAR	:	Kilo Volt Ampere Reactive
kW	:	Kilo Watt
kWh	:	Kilo Watt Hour
THD	:	Total harmonic distortion
LT	:	Low Tension
PF	:	Power Factor
PTR	:	PT Ratio
SEC	:	Specific Energy Consumption
TF	:	Transformer
UF	:	Utilization Factor
V	:	Voltage



ACKNOWLEDGEMENT

Power Tech Consultants (PTC) places on record its sincere thanks to Centurion University of Technology & Management for entrusting the task of conducting the Investment Grade Energy Audit of Centurion University of Technology & Management (CUTM), Paralakhemundi.

PTC acknowledges with gratitude the wholehearted support and encouragement given by all CUTM officials while carrying out the energy efficiency study at CUTM.

PTC acknowledges with gratitude and sincerely thanks all the officials and staff members of Centurion University of Technology & Management who have rendered their all possible co-operation and assistance to the study team during the entire period of the Audit.

Our special thanks to Dr. Anita Patra (Registrar), Prof. Durga Padhi, Prof. Asish Ranjan Dash, Mr. S. Ranjit Singh (Chief Technical Officer), Mr. Ramesh Sahoo and the Energy Conservation Cell Members for their whole hearted co-operation and guidance in carrying out the Investment Grade Energy Audit of CUTM, Paralakhemundi.

M/s. Power Tech Consultants

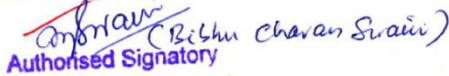
Authorised Signatory

Signature

Bibhu Charan Swain
Sr. Consultant
Accredited Energy Auditor
Regd. No - AEA-0121
Power Tech Consultants
K-8-82, Kalinga Nagar, Ghatikia, Bhubaneswar-751029, Odisha
Phone: 0674-2954256
Mobile: 9937112760, 9437155337
Email: pwrtech@gmail.com, Website: www.pwrtech.com





AUDIT TEAM DETAILS

1. Mr. Bibhu Charan Swain, Sr. Consultant & Accredited Energy Auditor, Regd. No. – AEA-0121
2. Mr. Nilamani Behera, Sr. Consultant, Energy Auditor
3. Mr. Nirjhar Biswal, Assistant Manager (Project)
4. Mr. Suraj Kumar Bhujabala, Assistant Manager (Project)
5. Mr. Suresh Gurjar, Project Associate

CERTIFICATE

We certify the following

- The data collection has been carried out diligently and truthfully.
- All data measuring devices used by the auditor are in good working condition, have been calibrated and have valid certificate from the authorized approved agencies and tampering of such devices has not occurred.
- All reasonable professional skill, care and diligence had been taken in preparing the energy audit report and the contents thereof are a true representation of the facts.
- The investment grade energy audit has been carried out in accordance with the BEE prescribed norms.

M/s. Power Tech Consultants

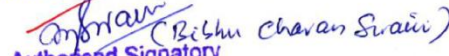
Authorised Signatory

Signature

Bibhu Charan Swain
Sr. Consultant
Accredited Energy Auditor
Regd. No - AEA-0121
Power Tech Consultants
K-8-82, Kalinga Nagar, Ghatikia, Bhubaneswar-751029, Odisha
Phone: 0674-2954256
Mobile: 9937112760, 9437155337
Email: pwrtch@gmail.com, Website: www.pwrtch.com





EXECUTIVE SUMMARY

Centurion University of Technology & Management (CUTM) is the only technological University in South Odisha, located at Village Alluri Nagar, P.O. – R Sitapur, Via- Uppalada Paralakhemundi, Dist: Gajapati, Odisha.

The journey of Centurion University of Technology and Management (CUTM) started with the takeover of Jagannath Institute for Technology and Management (JITM) in 2005. Subsequently, JITM was transformed into Centurion University of Technology and Management in August 2010, through an act of Odisha Legislative Assembly. The campus is spread over 120 acres on the foothills of the Eastern Ghats. The complex includes School of Fisheries, M.S Swaminathan School of Agriculture, School of Agriculture & Bio-Engineering, School of Paramedics & Applied Health Sciences, School of Management, School of Engineering and Technology, School of Vocational Education and Training and School of Applied Sciences.

Goals and Objectives of the Energy Management Programme:

The Investment Grade Energy Audit of Centurion University of Technology & Management, Paralakhemundi was carried out during the period in January 2022. Energy Conservation is a major focus and requirement in Institutional, Commercial and Government Buildings, and hence the management of Centurion University of Technology & Management, has entrusted the work of conducting Investment Grade Energy Audit (IGEA) of their entire campus to Power Tech Consultants. The main focus of the audit was to establish Specific Energy Consumption for all the Buildings & Vehicles for financial years 2018-19, 2019-20 and 2020-21 collection of technical information like specification of the machines, details of all the buildings, Fuel consumption in all the DG, Water consumption details, etc.

Centurion University of Technology & Management, Paralakhemundi is availing power supply from TPSODL, local DISCOM Connections at 33 kV Voltage level and through a 1MVA power transformer and three distribution transformers of 500kVA, 315kVA and 250kVA with contract demand of 850 kVA (Consumer no. 31200000022). The CUTM, Paralakhemundi campus also have roof top solar with the total capacity of 500 KWp (DC)/ 400 kW (AC). The solar panels are installed on the roof of CRC-1 building (100 kW AC), CRC-2 building (100 kW AC), MBA building (100 kW AC), ITI and Diploma building (60 kW AC) and Auditorium (60 kW AC). The power from solar panels is synchronized with the grid for consumption during day time. As per electricity bills analysis for FY 2020-21, the monthly average electrical energy consumption of whole campus stands at about 49006 kWh and the monthly average energy bill is around Rs. 455003, the average Power Factor is about 0.94.



SUMMARY OF THE ENERGY BILLS FOR THE LAST TWO FINANCIAL YEARS OF CUTM PARALAKHEMUNDI							
Year	Description	Electricity consumed in kWh	Avg. MD in kVA	Power Factor	Load Factor	Energy Bill in Rs.	Energy Charge in Rs./kWh
For Financial year 2020-21	Monthly average	49006	213	0.94	0.94	455003	9.71
	Daily Average	1634	213	0.94	0.94	15167	9.71
For Financial year 2021-22	Monthly average	91935	316	0.97	0.40	723110	7.87
	Daily Average	3065	316	0.97	0.40	24104	7.87

The major Utilities of Centurion University of Technology & Management, Paralakhemundi are Electricity, Water and HSD. The electricity is utilized for Lighting, Fans, Pumping of water, Computer, Printer, Laboratory, Water cooler, Fridge, Projector, Speaker and AC. HSD is utilized in DG set and Transportation Vehicles. Water consumption is there in all the buildings for day to day domestic purposes and also for plantation, gardening and cleaning.

During the study, various energy conservation options were identified, their cost benefit analysis was found out and same is furnished below. It is recommended that CUTM may implement the Energy Conservation Option as suggested in the report.



Investment Grade Energy Audit of CUTM, Paralakhemundi

Details of Energy Conservation measures / Recommendations of Accredited Energy Auditor for Improving Energy Efficiency						
[See rule 3(1) (c)]						
Energy Saving measures	Anticipated Investment (In Lakh)	Anticipated Annual Savings (In Lakh)	Simple Pay Back Period in Year	Anticipated Annual Energy Savings		
				Electricity in kWh	Thermal Energy in Gcal	Equivalent Energy in TOE
Reduction of Contract Demand in CUTM Paralakhemundi	Minor	6.00	Immediate			
Installation of Solar Water Heater at CUTM Canteen	0.13	0.06	2.128			
Installation of Biogas Plant at CUTM Canteen	4	2	2.0			
Installation of 3 kW Wind Plant	1.7	0.5	3.5			
Establishment of Solar Power Project in CUTM Paralakhemundi	177	35.28	5.01	588066		51
Replacement of Old 1.5 Ton AC with EESL 1.5 ton 5 Star Super Energy Efficient AC	98.7	22.97	4.30	382878		33
Replacing Conventional Ceiling Fan with 28W Super Energy Efficient Fan	77	40.1	2	668736		58
Total	359	107	3	1639680	0	141

1. Financial Benefit by Reduction in Contract Demand

Background:

The contract demand of CUTM, Paralakhemundi is 850 kVA however in majority of the months the maximum demand is within 480 kVA due to which the CUTM has to pay higher demand charges to the local DISCOM. In view of the same it is recommended to reduce the contract demand of CUTM to 600 kVA. There will be saving in demand charge of around of Rs. 50000 per month and annual financial saving will be Rs. 6 Lakh per annum. Investment required will be minor and payback period shall be immediate.



Cost Benefit Analysis

Cost Benefit Analysis for Reduction of Contract Demand in CUTM Paralakhemundi		
Particulars	Unit	Value
Present Contract Demand	kVA	850
Present Maximum Demand	kVA	480
Present Monthly Demand Charge	Rs. Per Month	170000
Future Contract Demand	KVA	600
Future Demand Charge	Rs. Per Month	120000
Monthly Saving in Demand Charge	Rs. Per Month	50000
Annual Saving by Reducing the Contract Demand	Rs. Lakh	6.00
Investment Required	Rs.	Minor
Simple Payback Period	Year	Immediate

2. Energy Conservation Option for replacement of old 1.5 Ton AC with EESL 1.5 ton 5 Star Energy Efficient AC

Background:

It is recommended that the existing 1.5 Ton AC to be replaced with EESL 1.5 Ton 5 Star rated AC. After replacement of old AC, the annual energy saving will be 382878 kWh, annual cost saving will be Rs. 23 Lakh. Around Rs. 98.7 Lakh of investment will be required and payback period shall be 4.3 years.

Cost Benefit Analysis of AC

Cost Benefit Analysis for Replacement of Old 1.5 Ton AC with EESL 1.5 ton 5 Star Super Energy Efficient AC		
Particular	Unit	Value
Present nos. of 1.5 Ton AC	Nos.	239
Total Capacity	TR	358.5
Av. Electrical Load of each existing AC before Replacement	kW	1.755
Total Av. Electrical Load before Replacement	kW	419.445
Annual Energy consumption without Energy Efficient AC @300*12hr	kWh	1510002
Present Load before Replacement	kW	419.445
Av. Electrical Load of new AC after Replacement	kW	1.31
Total Av. Electrical Load after Replacement	kW	313
Annual Energy consumption with EESL AC @300*12hr	kWh	1127124
Annual Energy Saving due to Installation of EESL Super Efficient AC	kWh	382878
Annual Cost of Savings @ Rs.6.0/unit	Rs. Lakh	23
Investment required	Rs. Lakh	98.7
Simple payback period	Years	4.3



3. Energy Conservation Option for replacing Conventional Fan with 28 W Energy Super Efficient Fan

Background:

It is observed that there is a scope in energy conservation in fan system by replacing Conventional Ceiling Fan with 28W Energy Super Efficient Fan. By using recommended fan the annual energy saving will be 668736 kWh and financial saving will be around Rs. 40.1 Lakh & investment required will be Rs. 77.4 Lakh with simple payback period of 1.9 Years.

Cost Benefit Analysis of Fan

Cost Benefit Analysis for Replacing Conventional Ceiling Fan with 28W Super Energy Efficient Fan		
Total No. of Fans Operating	Nos.	3870
Present Load before Replacement @ 100W per Fan	kW	387
Load after Replacement @ 28 W per Fan	kW	108
Saving in Load	kW	279
Run hour /Day	hr	8
Annual Energy Saving Assuming 300 Days	kWh	668736
Annual Energy Saving	TOE	58
Total Investment	Rs. Lakh	77.4
Annual Cost of Savings @ Rs 6/unit	Rs. Lakh	40.1
Simple Payback Period	Years	1.9

4. Financial Benefit by Installation of Solar Roof Top Plant at CUTM Paralakhemundi

Background:

It is recommended that after installation of Roof Top at CUTM Paralakhemundi, the annual energy generation will be 588066 kWh, annual cost saving will be Rs. 35.3 Lakh. Around Rs. 177 Lakh of investments will be required and payback period shall be 5 years.

Establishment of Solar Power Project in CUTM Paralakhemundi		
Units Generation	Unit	Value
Total Annual Energy Consumed from TPCODL in FY 2020-21	kWh	588066
Average Base Demand from TPCODL	kW	67
Proposed capacity of the Solar Power Project to be installed inside CUTM	MW	0.353
Total Area Required	Acre	1.24
Total Project Cost Required	Rs. Lakh	177



Capacity Utilization Factor	%	19%
Net Annual Generation	kWh	588066
Annual Energy Saving	TOE	51
Weighted Average Rate of Electricity	Rs./kWh	6
Annual Saving in Energy Bills due to Consumption from own solar power	Rs. Lakh	35.3
Simple Payback Period	Years	5

5. Financial Benefit by Installation of Solar Water Heater:

Background:

It is recommended that after installation of Solar Water Heater, the annual LPG saving @300days will be 63 Kg, annual cost saving will be Rs. 0.1 Lakh. Around Rs. 0.13 Lakh of investment will be required and payback period shall be 2.13 years.

Cost Benefit Analysis of Installation of Solar Water Heater at CUTM Canteen		
Particulars	Unit	Value
Total Hot Water required in Canteen per Day	Ltr	50
Consumption of LPG for heating Water	Kg	0.21
Annual LPG Consumption for heating water	Kg	63
Annual expenditure due to LPG consumption for solar water heating @ 93.2/Kg	Rs.	5875
Installation Cost of 50 LPD Solar Water Heater	Rs.	12500
Annual financial saving due to reduction in LPG consumption	Rs. Lakh	0.1
Investment required	Rs. Lakh	0.13
Simple Payback Period	Year	2.13

6. Financial Benefit by Installation of Wind Plant:

Background:

It is recommended that after installation of 3 kW Wind Plant, the annual generation will be 7884 kWh, annual cost saving will be Rs. 0.5 Lakh. Around Rs. 1.7 Lakh of investment will be required and payback period shall be 3.49 years.

Cost Benefit Analysis by Installation of 3 kW Wind Plant		
Particulars	Unit	Value
Installed Power Generation Capacity	kW	3
Capacity Utilization Factor	%	30
Net Annual Generation	kWh	7884
Rate of Electricity	Rs./kWh	6
Annual Saving in Energy Bills due to Consumption from own wind	Rs. in	0.5



plant	Lakh	
Investment Required	Rs. in Lakh	1.7
Simple Payback Period	Years	3.49

7. Financial Benefit by Installation of Biogas Plant:

Background:

It is recommended that after installation of Biogas Plant, annual LPG saving @300days will be 2100 kg, annual cost saving will be Rs. 1.96 Lakh. Around Rs. 4 Lakh of investment will be required and payback period shall be 2.04 years.

Cost Benefit Analysis by Installation of Biogas Plant at CUTM Canteen		
Particulars	Unit	Value
Total waste generated in Canteen per Day	Kg	140
Treatment Capacity of Waste per day	kg	100
Amount of Equivalent LPG Gas can be generated for 100 kg of Waste	Kg	7
LPG Gas can be saved per day	Kg	7
Annual LPG Saving @300 Days	Kg	2100
Annual Cost Saving Rupees @ 93.2/Kg	Rs. Lakh	1.96
For Installation 15 M3 Biogas for 100kg waste	Rs. Lakh	4
Simple Payback Period	Year	2.04

1.0 INTRODUCTION

The Government of India has enacted the Energy Conservation Act, 2001, with the objective of providing sustainable and more efficient management of our energy resources. The aim of Energy Conservation (EC) Act 2001 is to provide the much-needed legal framework and other institutional arrangements so that various energy efficiency improvement drives can be easily launched at the state and national level. In order to implement the various provisions under the EC Act 2001, the Government of India has established the Bureau of Energy Efficiency (BEE), to enact and enforce energy efficiency through various regulatory and promotional measures.

Energy Conservation has become a top most priority in today's scenario in order to have a sustainable growth, productivity, enhancement and Environmental Protection. Considering the vast potential of energy savings and benefits of energy efficiency as per the report prepared by National Development Council (NDC) Committee on power, Govt. of India enacted the Energy Conservation Act 2001. Accordingly, the Govt. of India set up



the Bureau of Energy Efficiency (BEE) under the provision of the Energy Conservation Act 2001 for development of policies and strategies with a thrust on self regulation and market principles, with the primary objective of reducing energy intensity of the Indian Economy.

Buildings consume significant portion of Energy for lighting, Air Conditioning, Ventilation purpose and hence Energy Conservation is a major focus and requirement in Institutional, Commercial and Government Buildings. Besides Building owners are also focusing Energy Conservation and Energy Efficiency in large extent for a higher productivity. Efficient Energy management, Usage of Energy Efficient Technologies and adopting best-practices that would help a Building Owner to reduce their energy cost considerably. Hence in order to identify the energy conservation opportunities and reduce the present energy consumption, the management of CUTM has entrusted the work of conducting Investment Grade Energy Audit (IGEA) to Power Tech Consultants. The Energy Audit of CUTM was carried out in the period of January 2022. The scope of work includes collection of existing layout of Building, Collection of various data including lighting inventory, AC list, Pump, Motor and other electrical load list, Collection of Month wise Energy Bill for FY 2019-20 to 2020-21 and available period for FY 2021-22, Power measurement of all running Transformer, Panels, AC, Pump and Motor and submission of Energy Audit Report along with details of Energy Conservation Opportunity.

1.1. About The Site

Centurion University of Technology & Management (CUTM) is the First Multi-Sector State Private University in Odisha, located at Village Alluri Nagar, P.O. – R Sitapur, Via-Uppalada Paralakhemundi, Dist: Gajapati, Odisha. The journey of Centurion University of Technology and Management (CUTM) started with the takeover of Jagannath Institute for Technology and Management (JITM) in 2005. Subsequently, JITM was transformed into Centurion University of Technology and Management in August 2010, through an act of Odisha Legislative Assembly. The campus is spread over 120 acres on the foothills of the Eastern Ghats. The complex includes School of Fisheries, M.S Swaminathan School of Agriculture, School of Agriculture & Bio-Engineering, School of Paramedics & Applied Health Sciences, School of Management, School of Engineering and Technology, School of Vocational Education and Training and School of Applied Sciences.

1.2. Scope of Works

- a) Review of present electricity consumption and fuel oil. Estimation of energy consumption in various loads like lighting, HVAC, DG Set etc in premises of the Building.



b) Electrical Distribution system:

- Review of present electrical distribution from the single line diagram (SLD). Study of operation/loading of distribution transformers, cable loading, normal and emergency loads, electricity distribution in various area/ floors and loss estimation.
- Study of reactive power management and option for power factor improvement, functioning of capacitor banks.
- Study of power quality, like harmonics, current unbalance, voltage unbalance etc.
- Exploring the energy conservation options (ENCON) in the electrical distribution system.

c) Lighting System

- Review of present lighting system, lighting inventories etc.
- Estimation of lighting load at various locations like different floors, outside (campus) light, pump house and other important locations.
- Detailed illuminations survey with measurement of LUX level at various locations and comparison with acceptable standards.
- Study of present lighting control system, lighting maintenance systems, present procedure for management of lighting spares and consumables and recommendation for improvement
- Analysis of lighting performance indices like LUX/m² LUX/Watt, LUX/Watt/m² and comparison of the same with benchmark.
- Exploring the possibility of retrofitting option with energy efficient lighting system like LED lamp, control Gears, sensors and automators, voltage regulators and solar based system.
- Developing a suitable lighting energy accounting and monitoring system.
- Exploring the energy conservation options (ENCON) in lighting system.

d) Heating Ventilation & Air conditioning system (HVAC system)

- Review of present HVAC system like Spilt AC, Window AC, water coolers and air heater etc.
- Performance assessment of window AC, and Split AC
- Analysis of HVAC performance like estimation of Energy Efficiency Ratio (EER) i.e. (KW/TR) and comparison of the operating data with the design data and recommendation for best prices/standard requirement.
- Exploring the energy conservation options (ENCON) in HVAC system

e) Diesel Generators (DG) sets

- Review of DG set operation
- Performance Assessment of DG sets in terms of specific fuel consumption (SFC i.e. kWh/Ltr.), Exploring the energy conservation options (ENCON) in lighting system.
- Exploring the energy conservation options (ENCON) in DG sets.



f) Water pumping system

- Review of water pumping, storage and distribution systems.
- Performance assessment of all major water pumps i.e. power consumption vs. flow delivered, estimation of pump efficiency etc and compare with best practices
- Study the flow control mechanism.
- Study of rational utilization of water pumping system, energy efficient retrofitting etc.

g) Motor Load survey

- Conducting the motor load survey.
- Survey of motor loading (% loading) for major electrical drives
- Measurement of all electrical parameters like voltage, current, PF & KW for all running motors and calculation of pump efficiency and suggestion for improvement.
- Study of mechanical power transmission system and suggest for energy efficiency
- Study of rational usage of drives for reducing electrical energy consumption.

h) Energy Monitoring & Accounting System:

- Detail Review of present energy monitoring & accounting system in terms of metering, record keeping, data logging, periodic performance analysis etc.
- Suggest for procedures for improvement in energy monitoring and accounting system.

i) UPS

- Measurement and analysis UPS loading, redundancy, operating efficiency, load pattern to suggest measures for energy cost reduction, measurement and analysis of Harmonic.

j) Others:

- Review of present maintenance practice, replacement policies and building safety practices as applicable to high rising buildings and recommend for improvement.
- Cost benefit Analysis of each ENCON indicating simple payback period, return of investment (ROI) internal rate of return (IRR)

1.3. Methodology

The following step by step methodology and approach were adopted to carry out the Investment Grade Energy Audit Report of CUTM, Paralakhemundi. Prior to energy audit, PTC team made a walk through survey of the Building and associated subsystems to assess the followings:-



- The existing layout of Building.
- Collection of various data including lighting inventory, AC list, Fan list, Motor and other electrical load list.
- Collection of Month wise Energy Bill for FY 2019-20 to 2021-22.

The methodology was explained / discussed with CUTM, Paralakhemundi officials. The broad methodology adopted for the Energy Audit at CUTM is furnished below.

1. The program of visit of energy audit team to site for carrying out the IGEA work was informed to CUTM, Paralakhemundi officials.
2. Data collection and Energy Bill Collection was carried out through discussions with the officials and from past records, log books.
3. Technical specification of equipments and their operating parameters were collected, while visiting the area. The data so collected were analyzed and the deviations were noted.
4. Performance of the major energy consuming equipments was analyzed.
5. Measurement of electrical energy parameters, wherever possible, using portable instruments were carried out.
6. Power Measurement of all running Transformer, Panels, AC was carried out using portable power analyzer brought by PTC for this purpose.
7. Review of present lighting system, lighting inventories collection were carried out. Estimate all lighting load at various locations like different parts of Building, outside area i.e. street lighting and area lighting and other important locations. Also detailed illuminations survey was determined with measurement of LUX level at various locations.
8. Ambient parameters (Temperature, Humidity) were measured using portable test instrument brought by PTC.
9. Energy Conservation option were identified and tabulated on the basis of priority.
10. Draft soft copy of energy audit report comprising of observations and recommendations with adequate financial justification, vendor support data, etc. was prepared and submitted to CUTM, Paralakhemundi for acceptance.
11. Final energy audit report was submitted after acceptance of the draft energy audit report.

1.4. Instruments Used

PTC have a wide array of latest, sophisticated, portable, diagnostic and measuring instruments to conduct energy audit investigations and analysis. The following special portable instruments are used to carry out various field measurements and analysis during the energy audit period.

- Three Phase Power Analyzer(ALM-30)
- Clamp on electrical power analyzers



- Infrared Non-Contact Thermometer
- Anemometer
- Hygrometer
- Lux Meter
- Power Guard

2.0 BRIEF DESCRIPTION OF THE UNIVERSITY

Name & Address

Centurion University of Technology & Management
Village Alluri Nagar, R Sitapur, Via- Uppalada, Paralakhemundi
Dist: Gajapati, Odisha- 761211
Tel +91 8260077222

Name & Details of Authorized Signatory of CUTM, Paralakhemundi

Dr. Anita Patra (Registrar)
Mobile: - 9437424149
E-mail:- anita@cutm.ac.in

Name & Details of Project Coordinator

Mr. S. Ranjit Singh (Chief Technical Officer)
Mobile: - 9437623021
E-mail:- ranjit.singh@cutm.ac

DESCRIPTION OF CAMPUS:

Centurion University of Technology & Management (CUTM) is the First Multi-Sector State Private University in Odisha, located Village Alluri Nagar, R Sitapur, Via- Uppalada, Paralakhemundi, Odisha 761211, Spread over 120 acres on the foothills of the Eastern ghats in a serene environment lies the main campus of Centurion University in Paralakhemundi. It is the only technological University in South Odisha. It is located at latitude 18°48'26"N & longitude 84°08'27" E. Nearest Railway station is Paralakhemundi junction.

The complex includes CRC-1 Building, CRC-2 Building, ITI Building, MBA Building, Mechanical Department Building, Old Guest House, MDC Guest House Nine Buildings of Boy's Hostel, Three Buildings of Girls Hostel, Five Staff Quarter, Mechanical Lab, Dynamic and Vibration & Thermal Engg , Heat Tranfer Lab, Mini Tool room & Training Centre, Mini Dairy Unit, Studio Apartment, Student Activity Center, Eicher Lab, Central Mess-1 & 2, Store Office, Library, Bio fertiliser Lab, Auditorium and Power House Station.

University is having approximately 223 numbers of teaching staff members, 2896 numbers of Students, 4 nos. of Electrician, and 4 nos. of Plumber, Electrical Contactor-2 are there.



Centurion University of Technology & Management, Paralakhemundi is availing power supply from TPSODL, local DISCOM Connections at 33 kV Voltage level and through a 1 MVA power transformer and three number of distribution transformers of 500kVA, 315 kVA and 250kVA with contract demand of 850 kVA (Consumer no. 31200000022). One number of DG Set i.e. DG Set-1 (380 kVA). The CUTM, Paralakhemundi campus also have roof top solar with the total capacity of 500 KWp (DC)/ 400 kW (AC). The solar panels are installed on the roof of CRC-1 building (100 kW AC), CRC-2 building (100 kW AC), MBA building (100 kW AC), ITI and Diploma building (60 kW AC) and Auditorium (60 kW AC). The power from solar panels is synchronized with the grid for consumption during day time. In the campus total 220 numbers of street lights & 153 numbers of solar based street lights are there. Four numbers of Sump and 15 nos. of Water Tank and 4 nos. of STP (Sewerage Treatment Plant) are available in CUTM, Paralakhemundi. Total 14 nos. of Motors are available and total water consumption of the campus per day is about 881 kL.



(Google Earth View of CUTM, Paralakhemundi)

2.1 Major Utility

- Electricity
- Water
- HSD



Electricity:

Electricity is utilized for Lighting, Fans, Pumping of water, Computer, Printer, Laboratory, Water cooler, Fridge, Projector, Speaker and AC, etc.

Water:

Water consumption is in all the Buildings for day to day usage and also utilized in plantation, gardening and cleaning.

HSD:

HSD is consumed in DG set and Transportation.

3.0 ENERGY SCENARIO

CUTM receives the electrical power supply from TPSODL at 33 kV. The present contract demand of the Building with TPSODL is 850 kVA. The energy fact file of the building is furnished below:

Table 1: Energy Fact File of CUTM, Paralakhemundi

Location	Centurion University of Technology & Management (CUTM), Village Alluri Nagar, R Sitapur, Via- Uppalada, Paralakhemundi, Odisha- 761211
Areas of Utilization of Energy	CUTM, Paralakhemundi
Source of Supply	33 KV Distribution Line from Paralakhemundi Substation of TPCODL
Total Contract Demand	850 kVA
Major Loads	Lighting & Power, Air Conditioning, Heating & Cooling, , Computers , Printers, Fans, Pump, Motor, DG Set , Household Appliances and Other loads
Usage Hours	Mainly 09.00 am to 6.00 pm on all working days
Monthly Energy Consumption	Avg. 49006 kWh per Month based on FY 2020-21
Monthly Energy Bill	Avg. Rs. 455003 per month based on FY 2020-21

Building Audit Data Sheet		
Sl. No.	Item	Value
Size, Age & Construction of the building		
1	Connected Load (kW) or Contract Demand (kVA)	850
2	Installed Capacity: DG Sets (KVA or KW)	380



3	a) Annual Electricity Consumption ,Purchased From Utilities(kWh)	588066	
	b) Annual Electricity Consumption, Through Diesel Generating DG Set (kWh)	NA	
	c) Total Annual Electricity Consumption (kWh)	588066	
4	a) Annual Cost Electricity Purchased from Utilities (Rs.)	5460033	
5	Built Up Area (sq m) (Excluding Basement Area)	485623	
6	Working days/week (e.g. 5/6/7 days per week)	6	
7	Installed lighting load(kW)	143379	
8	Installed capacity of Air Conditioning System(TR)	356	
9	Existing EPI(Energy performance Index) in kWh/sq. m/year Energy includes	0.00	
10	HSD Purchased for DG per year in Rs. for FY 2020-21	393015	
11	Occupancy Information	Staff Members	576

3.1 Analysis of Energy Bill

The energy bills details and tariff categorization details of CUTM, Paralakhemundi for FY' 2020-21 to FY' 2021-22 having consumer no- 31200000022 is furnished below:

Table 2: Consumer details of the Building

Consumer Name & Address	THE REGISTRER (CUTM) UPPALADA
Tariff Category	SPP
Consumer No.	31200000022
Contract Demand	850
Supply Voltage	33 kV

Data source: Energy Bills of CUTM were collected during the period of Energy audit.

The summary of Energy Bill Analysis of The CUTM, Paralakhemundi is furnished below:

Table 3: Summary of Energy Bill Analysis of CUTM, Paralakhemundi

The summary of Energy Bill Analysis of CUTM, Paralakhemundi Building is furnished below:

SUMMARY OF THE ENERGY BILLS FOR THE LAST TWO FINANCIAL YEARS OF CUTM PARALAKHEMUNDI							
Year	Description	Electricity consumed in kWh	Avg. MD in kVA	Power Factor	Load Factor	Energy Bill in Rs.	Energy Charge in Rs./kWh
For Financial year 2020-21	Monthly average	49006	213	0.94	0.94	455003	9.71
	Daily Average	1634	213	0.94	0.94	15167	9.71
For Financial year 2021-22	Monthly average	91935	316	0.97	0.40	723110	7.87



Investment Grade Energy Audit of CUTM, Paralakhemundi

	Daily Average	3065	316	0.97	0.40	24104	7.87
--	---------------	------	-----	------	------	-------	------

Note: We collected the bill for FY' 2021-22 from the period of April-2021 to December 2021.



Table 4: Energy Bill of CUTM, Paralakhemundi for FY' 2020-21

SUMMARY OF ENERGY BILL of CUTM PARALAKHEMUNDI FOR FINANCIAL YEAR 2020-21																			
Month	Energy Consumed in kWh	Av. Load Factor	Av. Power Factor	MD in kW	MD in kVA	Energy Charge in Rs.	Demand Charge in Rs.	PF Penalty (+ve) / PF Incentive (-ve)	Rebate	CSC	TOD Incentive	Overdrawl Penalty	Delay Payment Surcharge	Interest on Security	Meter Rent in Rs.	Electricity Duty	Current Monthly Bill in Rs.	Energy Charge in Rs./kWh	Unit cost in Rs. per kWh
Apr-20	55956	1	1	105	108	287918	24300	-983	3045	250	288648	0	0	0	1000	23033	327544	6.27	5.15
May-20	73680	0.58	0.99	177.52	180	383206	40500	-3432	4215	250	54912	0	0	0	1000	30656	452180	6.55	5.20
Jun-20	51468	0.38	0.97	186.47	192	268151	169999	-263	5937	250	36012	0	0	0	1000	21452	615142	12.37	5.21
Jul-20	32412	0.39	0.97	115.92	120	169221	169999	0	4844	250	20916	0	0	0	1000	13538	497895	15.78	5.22
Aug-20	47520	0.58	0.95	113.47	120	248078	169999	0	4325	250	30768	0	0	0	1000	19846	452341	9.94	5.22
Sep-20	39588	0.14	0.92	387.37	420	206917	169999	0	3782	250	24396	0	0	0	1000	16553	394719	10.39	5.23
Oct-20	35304	0.27	0.91	185.01	204	191384	169999	2367	3650	250	22764	0	0	0	1000	15311	380311	11.21	5.42
Nov-20	23280	0.33	0.92	98.87	108	126288	169999	667	2982	250	14580	0	0	0	1000	10103	308306	13.68	5.42
Dec-20	26124	0.23	0.90	161.19	180	141619	170000	3817	3167	250	16848	0	0	0	1000	11329	328015	12.99	5.42
Jan-21	35496	0.22	0.88	221.46	252	192044	170000	7458	3708	250	24792	0	0	0	1000	15364	386116	11.31	5.41
Feb-21	30468	0.18	0.94	237.69	252	165164	170000	0	3364	250	19668	0	0	0	1000	13213	349627	11.91	5.42
Mar-21	136770	0.47	0.95	402.16	423	745953	170000	0	9088	250	8374	0	0	0	1000	59006	967836	7.51	5.45
Total / Av.	588066	0.37	0.94	199.38	213.24	3125944	1764793	9631	52106	3000	562678	0	0	0	12000	249406	5460033	9.71	5.32
Monthly Average	49006	0.37	0.94	199.38	213.24	260495	147066	803	4342	250	46890	0	0	0.00	1000	20784	455003	9.71	5.32
Daily Average	1634	0.37	0.94	199.38	213.24	8683	4902	27	145	8	1563	0	0	0.00	33	693	15167	9.71	5.32

From the Energy Bill of FY 2020-21 it is observed that Average Demand in this year is 199.38 KW i.e. 213.24 kVA with an Average Power Factor of 0.94.



Table 5: Energy Bill of CUTM, Paralakhemundi for FY' 2021-22

SUMMARY OF ENERGY BILL of CUTM PARALAKHEMUNDI FOR FINANCIAL YEAR 2021-22																		
Month	Energy Consumed in kWh	Energy Consumed in kVAh	Av. Load Factor	Actual Power Factor	MD in kW	MD in kVA	Energy Charge in Rs.	Demand Charge in Rs.	Rebate	CSC	TOD Incentive	Overdrawl Penalty	Delay Payment Surcharge	Meter Rent in Rs.	Electricity Duty	Current Monthly Bill in Rs.	Tariff in Rs./kVAh	Tariff in Rs./kWh
Apr-21	113370	116658	0.34	0.97	466	480	651832	170000	8164	250	6581	0	0	1000	51620	869158	7.45	7.67
May-21	43476	46584	0.32	0.93	190	204	189049	170000	3569	250	3389	0	0	1000	14853	371763	7.98	8.55
Jun-21	35616	36900	0.38	0.97	127	132	153176	170000	3217	250	2743	0	0	1000	12035	333718	9.04	9.37
Jul-21	45480	46860	0.37	0.97	163	168	237146	170000	4057	250	2940	0	0	1000	18758	424485	9.06	9.33
Aug-21	67674	70074	0.34	0.97	279	289	365531	170000	5329	250	3842	0	0	1000	28935	561874	8.02	8.30
Sep-21	154134	152670	0.46	1.01	462	458	891084	170000	10557	250	6587	0	0	1000	70760	1126507	7.38	7.31
Oct-21	146172	148638	0.46	0.98	441	448	867988	170000	10320	250	7279	0	0	1000	68857	1100815	7.41	7.53
Nov-21	138426	141846	0.51	0.98	377	386	825657	170000	9896	250	7283	0	0	1000	65470	1055741	7.44	7.63
Dec-21	83070	85579	0.43	0.97	267	276	460237	170000	6265	250	5021	0	0	1000	36417	663929	7.76	7.99
Total / Av.	827418	845809	0.40	0.97	308	316	4641701	1530000	61375	2250	45665	0	0	9000	367705	6507989	7.69	7.87
Monthly Average	91935	93979	0.40	0.97	308	316	515745	170000	6819	250	5074	0	0	1000	40856	723110	7.69	7.87
Daily Average	3065	3133	0.40	0.97	308	316	17191	5667	227	8	169	0	0	33	1362	24104	7.69	7.87

From the Energy Bill of FY 2021-22 it is observed that Average Demand in this year is 308KW i.e. 316 kVA with an Average Power Factor of 0.97.



Figure 1: Trend of Energy Consumption of CUTM, Paralakhemundi

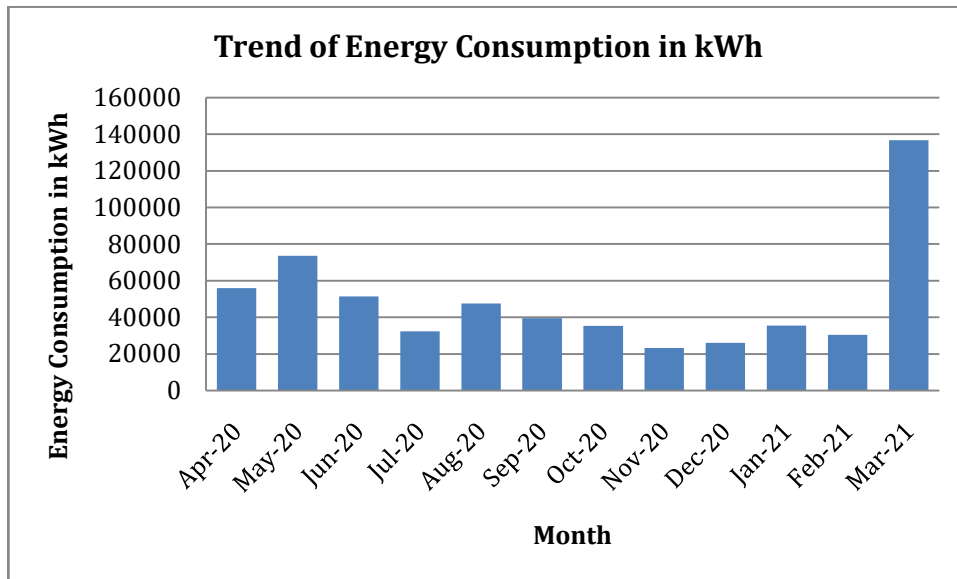

Figure 2: Trend of MD of CUTM, Paralakhemundi

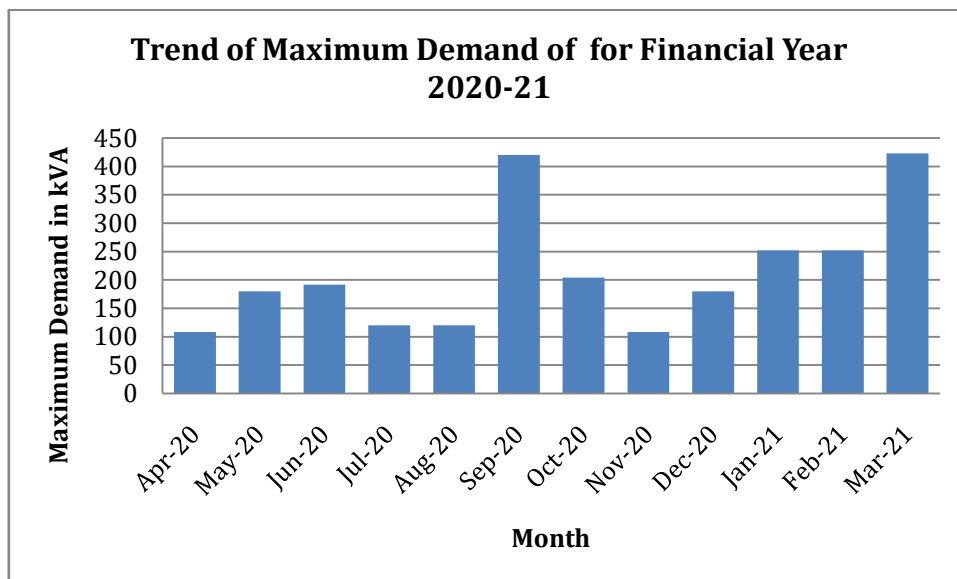



Figure 3: Trend of Energy Consumption of CUTM, Paralakhemundi

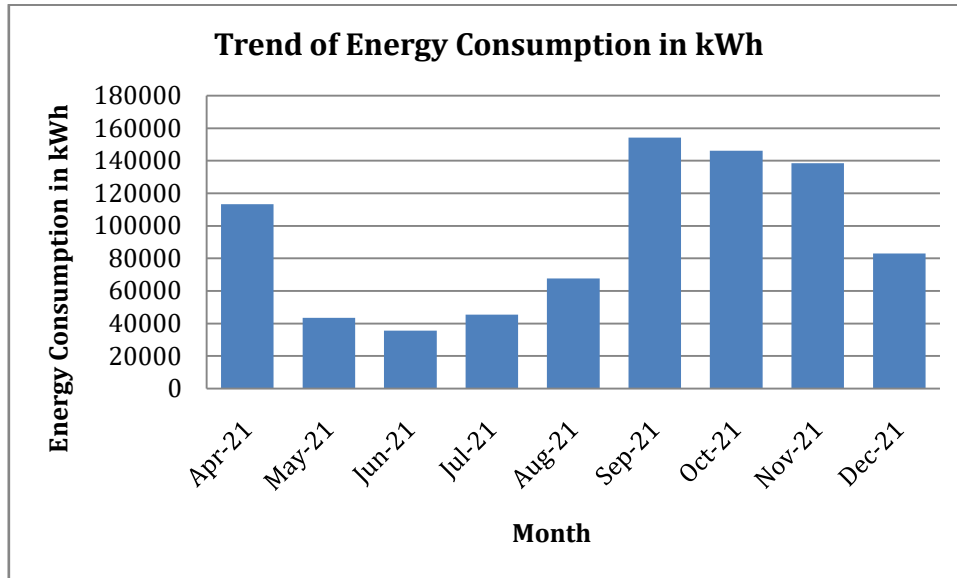
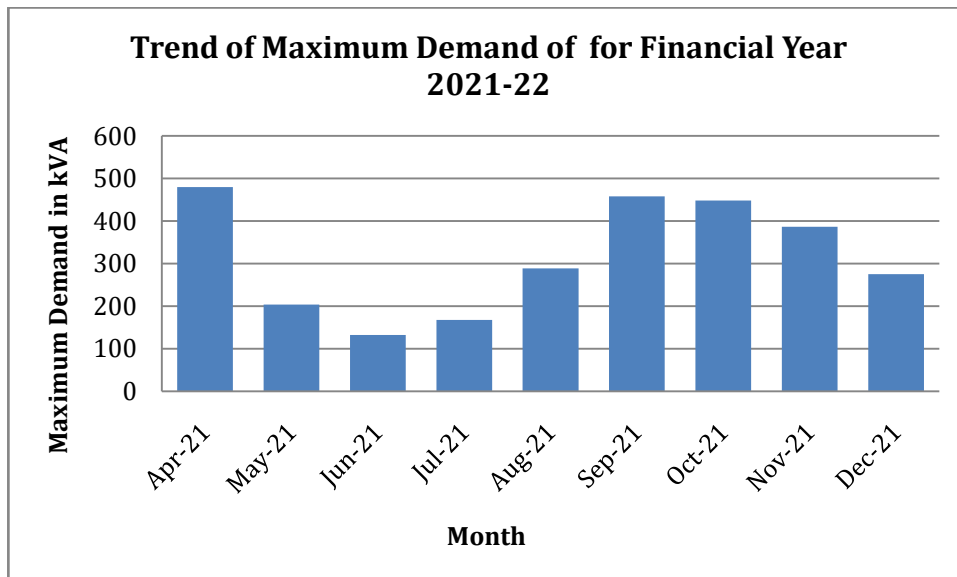

Figure 4: Trend of MD of CUTM, Paralakhemundi





Energy Conservation Option:

Background:

The contract demand of CUTM, Paralakhemundi is 850 kVA however in majority of the months the maximum demand is within 480 kVA due to which the CUTM has to pay higher demand charges to the local DISCOM. In view of the same it is recommended to reduce the contract demand to 600 kVA. There will be saving in demand charge of around of Rs. 50000 per month and annual financial saving will be Rs. 6 Lakh per annum. Investment required will be minor and payback period shall be immediate.

Table 6: Cost Benefit Analysis

Cost Benefit Analysis for Reduction of Contract Demand in CUTM Paralakhemundi		
Particulars	Unit	Value
Present Contract Demand	kVA	850
Present Maximum Demand	kVA	480
Present Monthly Demand Charge	Rs. Per Month	170000
Future Contract Demand	KVA	600
Future Demand Charge	Rs. Per Month	120000
Monthly Saving in Demand Charge	Rs. Per Month	50000
Annual Saving by Reducing the Contract Demand	Rs. Lakh	6.00
Investment Required	Rs.	Minor
Simple Payback Period	Year	Immediate

3.2 Base Line Energy Consumption and Specific Energy Consumption

During our audit it is seen that the load drawl pattern of CUTM, Paralakhemundi is typical of a unit functioning in day time but the Hostel and Admin building, are functioning beyond office hours. At night time minimum illumination inside the building and full outside lighting with street-lights are maintained. The office working hours in CUTM, Paralakhemundi is from 09 AM to 6PM normally for 350 days in a year. During the office period normal loads are room lighting, fans, ACs and office appliances. During the entire office working hours the load remains steady with small variations.

Connected load details & corresponding kW consumption

From the inventory survey, it is estimated that there is a connected load of about 1738 kW in CUTM, Paralakhemundi. It may be seen that the lighting load constitutes about 8 % of the total load, the Fan load constitutes about 24 % of the total load, the other load constitutes about 23 % of the total load and air conditioning loads share about 45 % of the total connected load. The following table indicates the estimated connected load details.



Table 7: Connected load details & corresponding kW

Summary of Electrical Load	
Load Centre	Kilo Watt
Lighting	143.727
Fan	409.271
AC	784.625
Other Load	401.068
Total	1738.691

Figure 5: Pie Chart of Connected Load Details & Corresponding kW Consumption

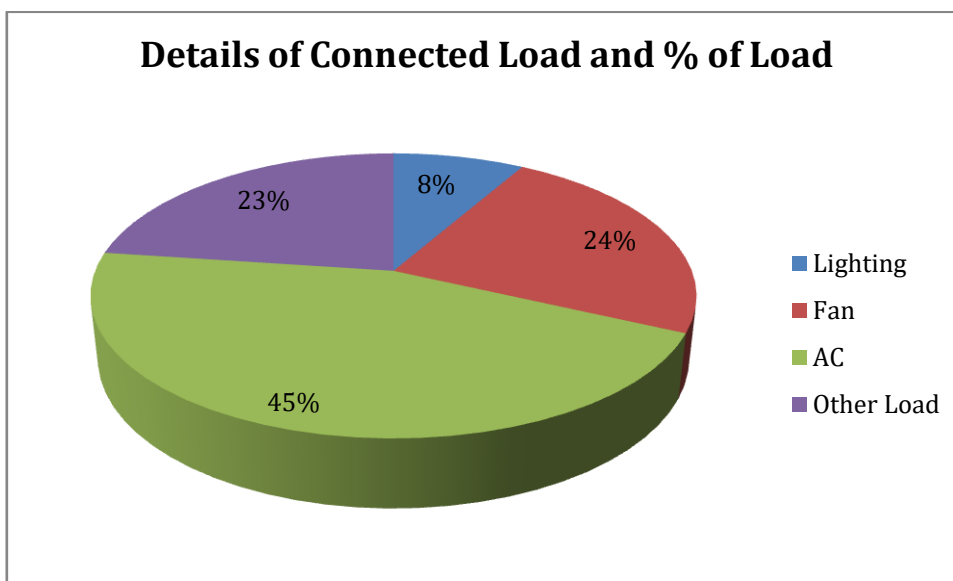

Table 8: Detail lighting inventory of all the units of CUTM, Paralakhemundi

Lighting Inventory				
Area Name	Types of Load	Wattage of each load in Watt	Nos. installed	Total connected Wattage in Watt
CRC 1	T5 Tube Light	20	94	1880
	Old Tube Light	40	93	3720



	Round LED	18	48	864
	LED	9	3	27
CRC 2	T5 Tube Light	20	48	960
	Old Tube Light	40	40	1600
	2ft 2 ft LED	36	26	936
	Round LED	18	12	216
	LED	9	21	189
Eicher Lab	T5 Tube Light	20	15	300
	2ft 2 ft LED	36	27	972
Mechanical Workshop Lab	T5 Tube Light	20	4	80
	2ft 2 ft LED	36	25	900
Central Mess 1	T5 Tube Light	20	9	180
	2ft 2 ft LED	36	20	720
Central Mess 2	Old Tube Light	40	4	160
	2ft 2 ft LED	36	12	432
ITI Building	Old Tube Light	40	25	1000
	2ft 2 ft LED	36	20	720
MBA Block	T5 Tube Light	20	186	3720
	2ft 2 ft LED	36	30	1080
Store Office	T5 Tube Light	20	15	300
	LED	9	1	9
Hostel for Tribal students SAIL	T5 Tube Light	20	106	2120
	LED	9	208	1872
	Outdoor LED	50	3	150
Library	T5 Tube Light	20	42	840
	Old Tube Light	40	1	40
	2ft 2 ft LED	36	53	1908
	Round LED	18	3	54
Student Activity Centre	T5 Tube Light	20	57	1140
	LED	50	6	300
Boys Hostel 1	T5 Tube Light	20	100	2000
	Round LED	18	9	162
Boys Hostel 2	T5 Tube Light	20	633	12660
	LED	9	632	5688
	LED	50	2	100
Boys Hostel 4	T5 Tube Light	20	633	12660
	LED Bulb	9	632	5688
	LED	50	2	100
Boys Hostel 5	T5 Tube Light	20	144	2880
	LED	9	36	324
CPS School Boys Hostel	T5 Tube Light	20	102	2040
	Old Tube Light	40	144	5760



Boys Hostel (Baitarani)	T5 Tube Light	20	34	680
	Round LED	18	4	72
	LED	9	32	288
Boys Hostel (Swarna Rekha)	T5 Tube Light	20	78	1560
	LED	50	1	50
Brahmani Girls Hostel	T5 Tube Light	20	58	1160
	LED	9	48	432
MT Girls Hostel	T5 Tube Light	20	206	4120
Indravati Girls Hostel	T5 Tube Light	20	108	2160
	LED	50	3	150
	LED Bulb	9	48	432
Mechanical Dept.	T5 Tube Light	20	28	560
	Old Tube Light	40	5	200
	Round LED	18	4	72
	Bulb	100	2	200
Dynamic and Vibration & Thermal Engg Lab	T5 Tube Light	20	2	40
	Old Tube Light	40	21	840
Bio fertiliser Lab	T5 Tube Light	20	2	40
	Old Tube Light	40	4	160
Studio Apartment	T5 Tube Light	20	40	800
	LED	9	13	117
MDC Hostel	T5 Tube Light	20	105	2100
	LED	9	28	252
Mini Tool Room & Training Centre	T5 Tube Light	20	16	320
	2ft 2 ft LED	36	8	288
	LED Bulb	9	3	27
Old Guest House	T5 Tube Light	20	7	140
	LED Bulb	9	10	90
Staff Qtrs	T5 Tube Light	20	180	3600
	LED Bulb	9	300	2700
	Round LED	18	45	810
CUTM School	T5 Tube Light	28	281	7868
	Flood Light	150	2	300
Auditorium	2ft 2 ft LED	36	50	1800
Mini Dairy Unit	T5 Tube Light	20	3	60
	Old Tube Light	40	3	120
Power House	T5 Tube Light	20	15	300
	Old Tube Light	40	2	80
	LED	50	5	250
	2ft 2 ft LED	36	1	36
Street Lights	Total street lights	45	220	9900
	Solar 18 W 12 V	18	153	2754



	Cricket Ground	350	12	4200
	Indoor Ground	250	4	1000
	Tennis Court	350	6	2100
	Basket ball	250	4	1000
	Net Practice Ground	250	4	1000
	Volleyball	250	4	1000
	Badminton Court	100	14	1400
	Flood Lights	150	6	900
	Sodium Vapour Lights	400	4	1600
	LED Pathway Lights (6 W per mtr)	6	300	1800
GYM	2ft 2 ft LED	36	3	108
	Old Tube Light	40	6	240
Total			6871	143727

Table 9: Detail Inventory of ACs

AC Inventory				
Area Name	Types of Load	Wattage of each load in kW	Nos. installed	Total connected Wattage in kW
CRC 1	Window AC	1.87	15	28.05
CRC 2	Window AC	1.87	29	54.23
Eicher Lab	Window AC	1.87	1	1.87
ITI Building	Window AC	1.5	1	1.5
	Split AC 1	2	2	4
	Split AC 2	1.5	5	7.5
MBA Block	Window AC	1.5	18	27
	Window AC	2.1	17	35.7
Library	Window AC	1.5	7	10.5
	Window AC	2.08	1	2.08
Student Activity Centre	Window AC	2.08	1	2.08
	Split AC 1.5 T	1.5	7	10.5
CPS School Boys Hostel	Split AC	1.5	4	6
Mechanical Dept.	Window AC	1.87	4	7.48
	Split AC	1.5	2	3
Bio fertiliser Lab	Split AC	1.5	1	1.5
Studio Apartment	Split AC	1.5	4	6
MDC Hostel	Window AC	1.87	45	84.15
Mini Tool Room & Training Centre	Window AC	1.87	4	7.48
	Split AC	1.5	2	3



Old Guest House	Window AC	1.87	2	3.74
	Split AC	1.5	2	3
Staff Qtrs	Split AC	1.5	60	90
CUTM School	AC	1.5	4	6
Auditorium	Centralised AC 3 units 35 Ton	123.095	3	369.285
Power House	Window AC	1.87	2	3.74
	Split AC	1.5	1	1.5
GYM	Window AC	1.87	2	3.74
Total			246	784.625

Table 10: Detail Inventory of All Types of Fan

Fan Inventory				
Area Name	Types of Load	Wattage of each load in kW	Nos. installed	Total connected Wattage in kW
CRC 1	Ceiling Fan	0.1	200	20
CRC 2	Ceiling Fan	0.1	126	12.6
Eicher Lab	Ceiling Fan	0.1	8	0.8
	Wall Fan	0.035	7	0.245
Mechanical Workshop Lab	Ceiling Fan	0.1	41	4.1
	Wall Fan	0.035	6	0.21
Central Mess 1	Ceiling Fan	0.1	44	4.4
	Exhaust Fan	0.075	3	0.225
Central Mess 2	Ceiling Fan	0.1	28	2.8
	Wall Fan	0.05	3	0.15
ITI Building	Ceiling Fan 1	0.1	7	0.7
	Ceiling Fan 2	0.07	43	3.01
	Ceiling Fan 3	0.05	1	0.05
	Wall Fan	0.05	22	1.1
MBA Block	Ceiling Fan	0.1	201	20.1
	Wall Fan	0.05	5	0.25
	Table Fan	0.075	9	0.675
Store Office	Ceiling Fan	0.1	4	0.4
	Wall Fan	0.05	1	0.05
	Exhaust Fan	0.075	1	0.075
Hostel for Tribal students SAIL	Ceiling Fan	0.1	110	11
Library	Ceiling Fan	0.1	62	6.2



	Wall Fan	0.035	1	0.035
	Stand Fan	0.15	1	0.15
Student Activity Centre	Ceiling Fan	0.1	35	3.5
	Wall Fan	0.035	3	0.105
	Exhaust Fan	0.075	6	0.45
Boys Hostel 1	Ceiling Fan	0.1	243	24.3
Boys Hostel 2	Ceiling Fan	0.1	632	63.2
	Wall Fan	0.035	1	0.035
Boys Hostel 4	Ceiling Fan	0.1	632	63.2
	Wall Fan	0.035	1	0.035
Boys Hostel 5	Ceiling Fan	0.1	207	20.7
CPS School Boys Hostel	Ceiling Fan	0.1	207	20.7
Boys Hostel (Baitarani)	Ceiling Fan	0.1	33	3.3
	Exhaust Fan	0.075	32	2.4
Boys Hostel (Swarna Rekha)	Ceiling Fan	0.1	27	2.7
	Exhaust Fan	0.075	5	0.375
	Wall Fan	0.035	27	0.945
Brahmani Girls Hostel	Ceiling Fan	0.1	51	5.1
	Exhaust Fan	0.075	48	3.6
MT Girls Hostel	Ceiling Fan	0.1	203	20.3
Indravati Girls Hostel	Ceiling Fan	0.1	96	9.6
	Exhaust Fan	0.075	48	3.6
	Wall Fan	0.035	1	0.035
Mechanical Dept.	Ceiling Fan	0.1	17	1.7
	Wall Fan	0.035	2	0.07
Dynamic and Vibration & Thermal Engg Lab	Ceiling Fan	0.1	23	2.3
Biofertiliser Lab	Ceiling Fan	0.1	2	0.2
	Exhaust Fan	0.075	1	0.075
Studio Apartment	Ceiling Fan	0.1	40	4
MDC Hostel	Ceiling Fan	0.1	104	10.4
	Exhaust Fan	0.075	16	1.2
Mini Tool Room & Training Centre	Ceiling Fan	0.1	10	1
Old Guest House	Ceiling Fan	0.1	8	0.8
Staff Qtrs	Ceiling Fan	0.1	180	18
CUTM School	Ceiling Fan	0.1	290	29
	Exhaust	0.075	1	0.075



	Fan			
Mini Dairy Unit	Wall Fan	0.035	4	0.14
	Big Wall Fan	0.746	1	0.746
	Exhaust Fan	0.075	3	0.225
Power House	Ceiling Fan	0.1	6	0.6
	Wall Fan	0.035	1	0.035
GYM	Ceiling Fan	0.1	12	1.2
Total			4193	409.271

Table 11: Detail Inventory of other appliances

Other Inventory of CUTM Paralakhemundi				
Building Name	Equipment	Watt	Quantity	Total connected Wattage in kW
CRC-1	Computer	125	16	2
	Projector	750	16	12
	Flow table Test Apparent Heater	500	1	0.5
	Printer	50	5	0.25
	Refrigerator	780	1	0.78
	CCTV	15	8	0.12
CRC-2	Computer	125	73	9.125
	Projector	750	7	5.25
	Speaker	40	7	0.28
Eicher Lab	Computer	125	1	0.125
	CCTV	15	2	0.03
	LED TV	100	1	0.1
Mechanical Workshop Lab	Geyser	2000	2	4
	CCTV	15	8	0.12
Central Mess1	Geyser	1500	1	1.5
	Water Cooler	625	1	0.625
	Aquagard	35	1	0.035
	CCTV	15	4	0.06
	Grinder	500	3	1.5
Central Mess 2	Refrigerator	780	1	0.78
	Water Cooler	625	1	0.625
	CCTV	15	3	0.045
	LED TV	45	1	0.045
	Speaker	40	3	0.12
ITI Building	Computer	125	64	8
	Geyser	2000	1	2



	Aquagard	48	1	0.048
	CCTV	15	7	0.105
	LED TV	55	9	0.495
	Generator(7000W/5kVA)	7000	1	7
	Motor	5500	3	16.5
	Motor	373	1	0.373
	Motor	1500	9	13.5
	Motor	746	2	1.492
	Motor	186	2	0.372
	Motor	2200	1	2.2
	Motor	3700	1	3.7
MBA Block	Computer	125	212	26.5
	Projector	150	11	1.65
	Printer	150	15	2.25
	Speaker	40	19	0.76
	Function Generator	12	20	0.24
	Ammeter	12	4	0.048
	CRO	20	3	0.06
	Smart Board	300	1	0.3
Store Office	Computer	125	2	0.25
	Printer	150	1	0.15
	CCTV	15	3	0.045
	Cutter Machine	250	1	0.25
	Mini Cutter	50	1	0.05
	Drying machine	40	1	0.04
Hostel for Tribal Students(SAIL)	Water Cooler	60	1	0.06
	CCTV	15	3	0.045
	LED TV	50	2	0.1
	Fire Extinguisher		3	
Library	Printer	150	1	0.15
	Water Cooler	625	1	0.625
	CCTV	15	6	0.09
	Router	6	2	0.012
	Battery 12V		16	0
Student Activity Centre	Computer	125	12	1.5
	Printer	50	4	0.2
	Xerox	930	1	0.93
	CCTV	15	4	0.06
	Fridge	100	1	0.1
Boys Hostel 1 (Mahanadi)	Router	6	9	0.054
Boys hostel 2	CCTV	15	7	0.105



Boys hostel 4	CCTV	15	7	0.105
Boys Hostel 5	CCTV	15	5	0.075
CPS Boys Hostel	Computer	125	24	3
	Printer	50	1	0.05
Boys Hostel (Baitarani)	Aqua Guard	30	1	0.03
	Water Cooler	60	1	0.06
Boys Hostel (Swarna Rekha)	Wi-Fi Router	6	1	0.006
M.T Girls Hostel	Water Cooler	625	1	0.625
Indravati Girls Hostel	Water Cooler	60	1	0.06
	Wi-Fi Router	6	6	0.036
Brahmani Girls Hostel	Water Cooler	60	1	0.06
	Wi-Fi Router	6	1	0.006
Mechanical Department Building	Computer	125	3	0.375
	Spring Test	746	1	0.746
	Brine Hardness test	373	1	0.373
	Torsion Testing M/c	746	1	0.746
	Hardness Tester (1 HP)	746	1	0.746
	Universal Testing M/c (3 HP)	2238	1	2.238
	Double disc polishing m/c	373	1	0.373
Dynamic and Vibration & Thermal Engg , Heat Transfer Lab	Computer	125	1	0.125
Bio fertiliser Lab	Refrigerator	780	2	1.56
Studio Apartment	Refrigerator	780	20	15.6
	Washing Machine	340	20	6.8
	Grinder	500	20	10
	Aqua Guard	30	20	0.6
MDC Hostel	Refrigerator	780	3	2.34
	Wi-Fi Router	6	12	0.072
	Geyser	2500	14	35
	TV	65	14	0.91
Mini Tool room & Training Centre	Computer	125	6	0.75
	Printer	50	2	0.1
Old Guest House	Fridge (Single)	100	1	0.1
	Induction Cook	1500	2	3
	Aqua Guard	30	1	0.03
	Router	6	1	0.006
Staff Qtrs (A,B,C,D,E type)	Fridge	100	60	6
	TV	65	60	3.9
	Aqua Guard	30	60	1.8
CUTM School	Computer	125	22	2.75



Investment Grade Energy Audit of CUTM, Paralakhemundi

	Projector	750	171	128.25
	Router	6	12	0.072
	Xerox	980	1	0.98
	Printer	50	1	0.05
	Water Cooler	625	2	1.25
	Motor (Fire) 5 HP	3730	1	3.73
	Motor (Bore well) 3 HP	2238	1	2.238
	Motor 1 HP	746	2	1.492
Auditorium	Speakers (side)	40	12	0.48
	Speakers (Ceiling)	40	30	1.2
	Speaker 1	300	3	0.9
	Speaker 2	650	1	0.65
	Amplifier 1	250	3	0.75
	Amplifier 1	700	2	1.4
	CCTV Monitor	50	1	0.05
	Computer	125	1	0.125
	Projector	780	3	2.34
	Mini Dairy Unit	Induction Cook	1500	1
Air Compressor 1 HP		746	1	0.746
Instant Refrigerator 5 HP		3730	1	3.73
Homogeniser 5 HP Motor		3730	1	3.73
Milk Feed Pump 0.5 HP		373	1	0.373
Hot Water Pump		746	1	0.746
Feed Motor		373	1	0.373
Milk Packing m/c		2000	1	2
Kova m/c		746	1	0.746
Heater (Curd Making)		5000	1	5
Refrigerator		165	2	0.33
Insect Killer		20	1	0.02
CCTV		15	2	0.03
Monitor		50	1	0.05
Power House Station	Geyser	2000	1	2
	Computer	125	1	0.125
GYM	Aqua Guard	35	1	0.035
Total				401.068



3.3 Electrical Distribution System and Water Distribution System

The Power Supply system of CUTM, Paralakhemundi was studied and based on the observations; the single Line Diagram of Existing Electrical distribution system of CUTM is drawn and furnished below.

Figure 6: Electrical Distribution System for 33/11 Transformer

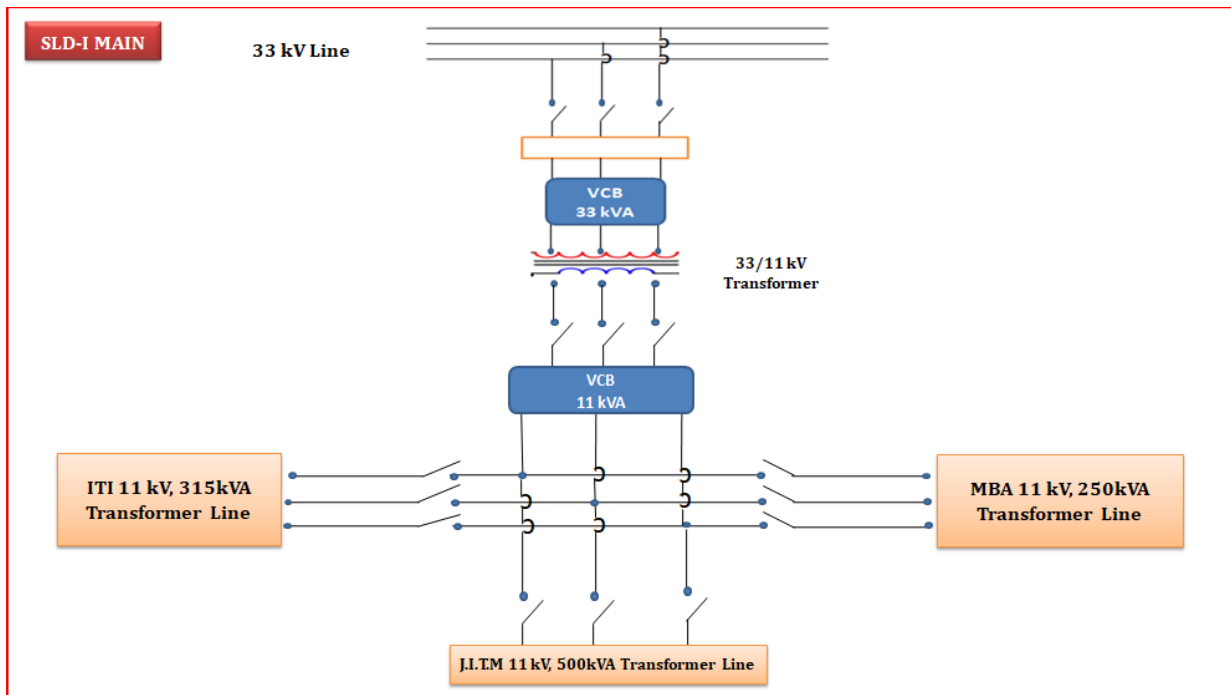

Figure 7: Electrical Distribution System for ITI & MBA

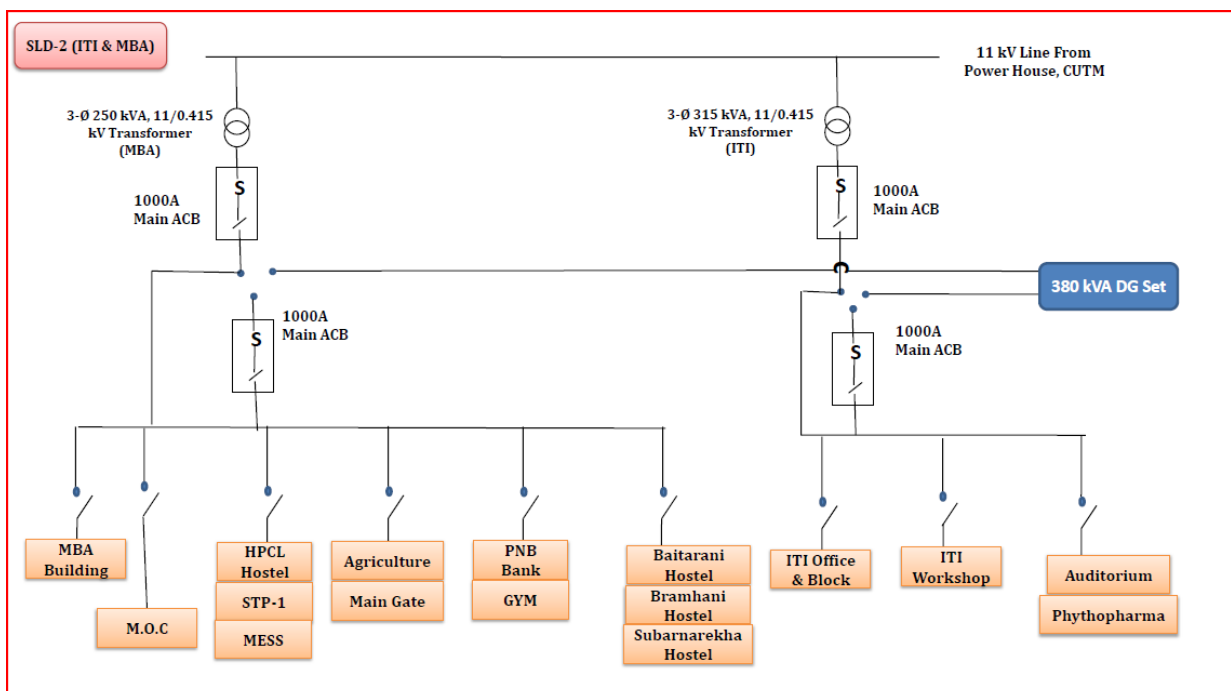



Figure 8: Electrical Distribution System for JITM

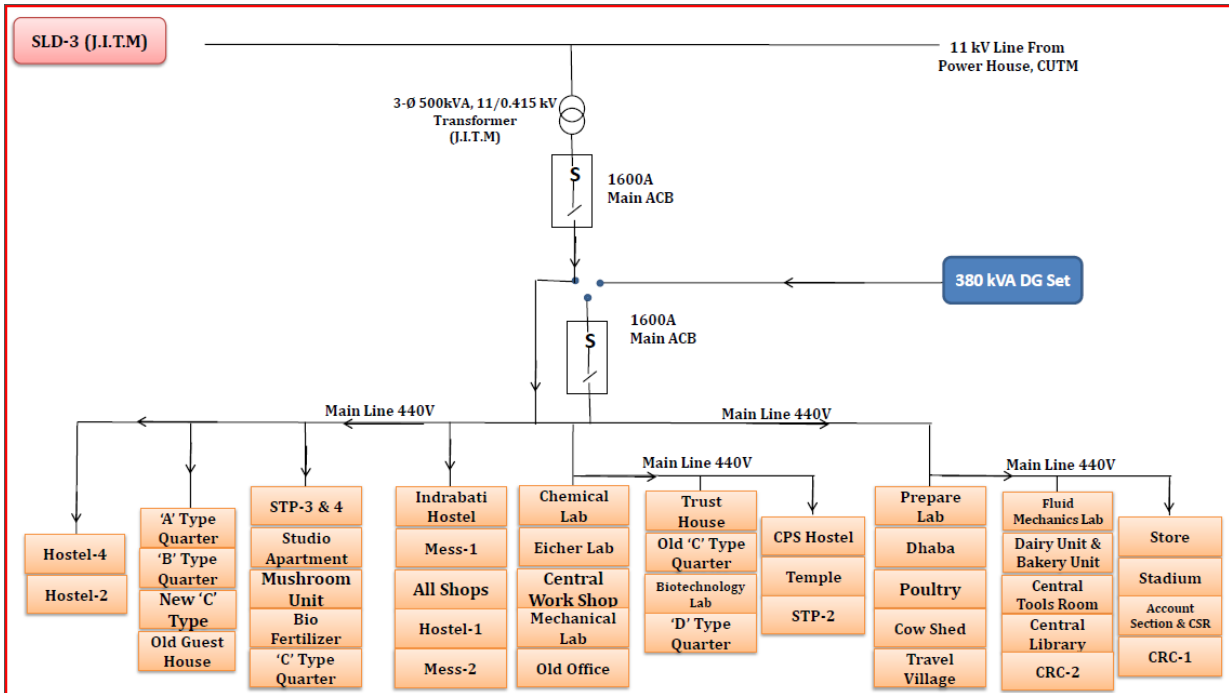

Figure 9: Water Distribution System Phase-1

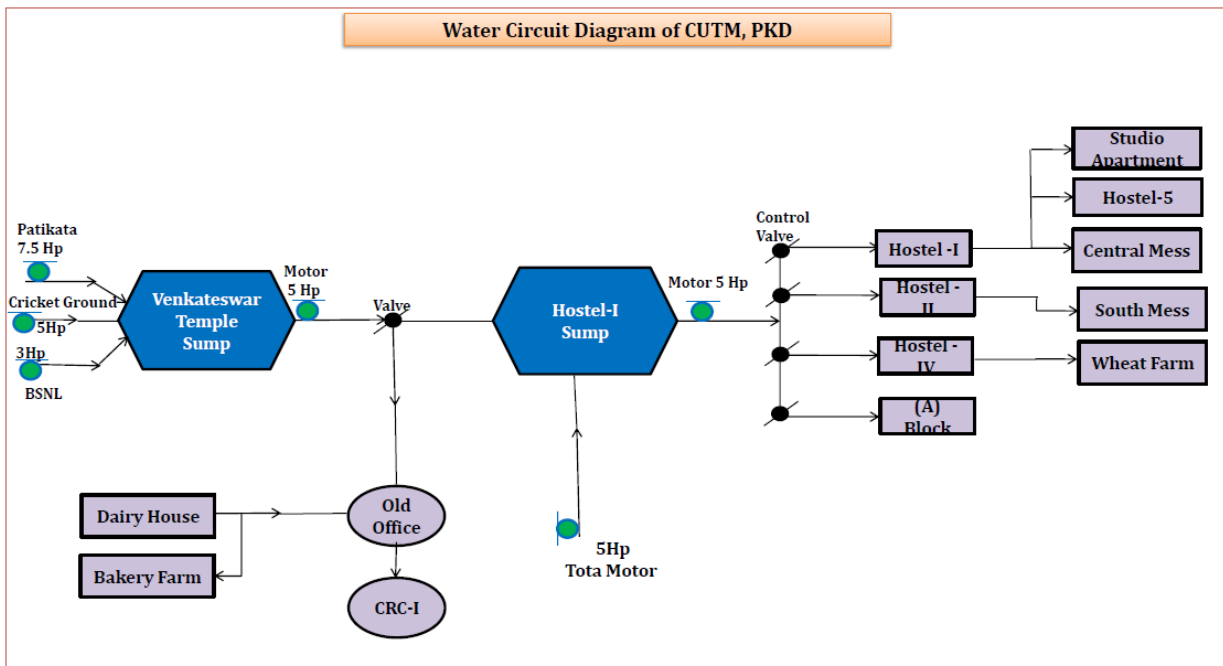



Figure 10: Water Distribution System Phase-2

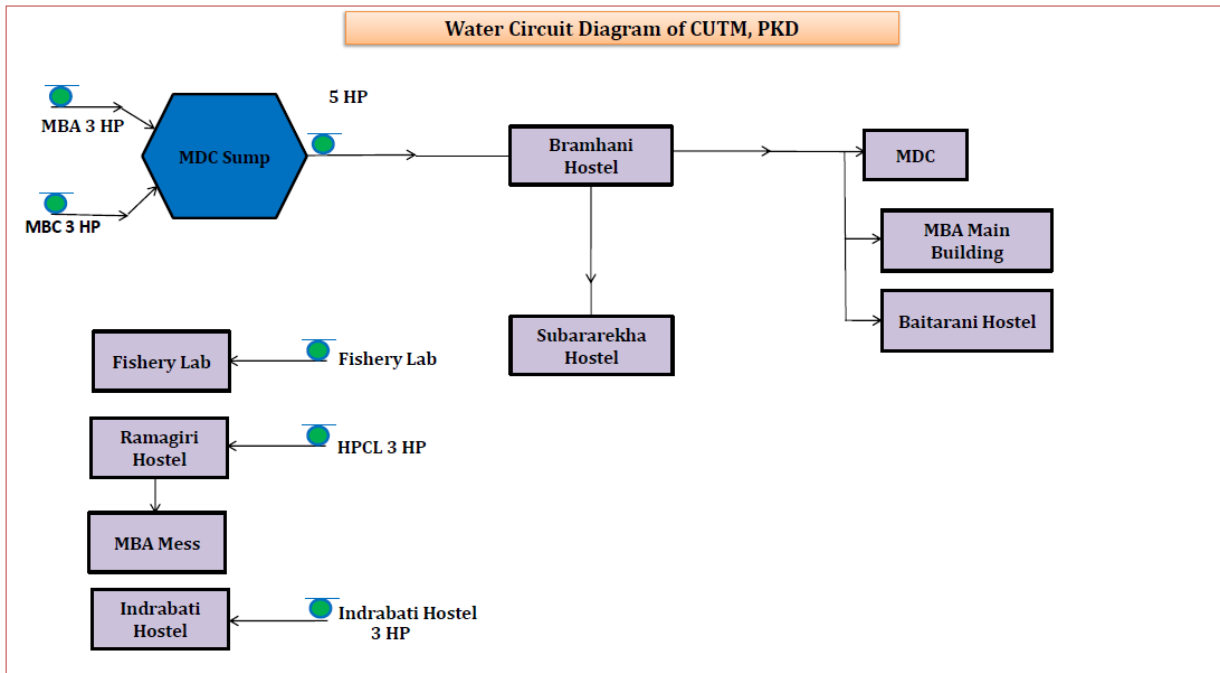

Figure 11: Water Distribution System Phase-3

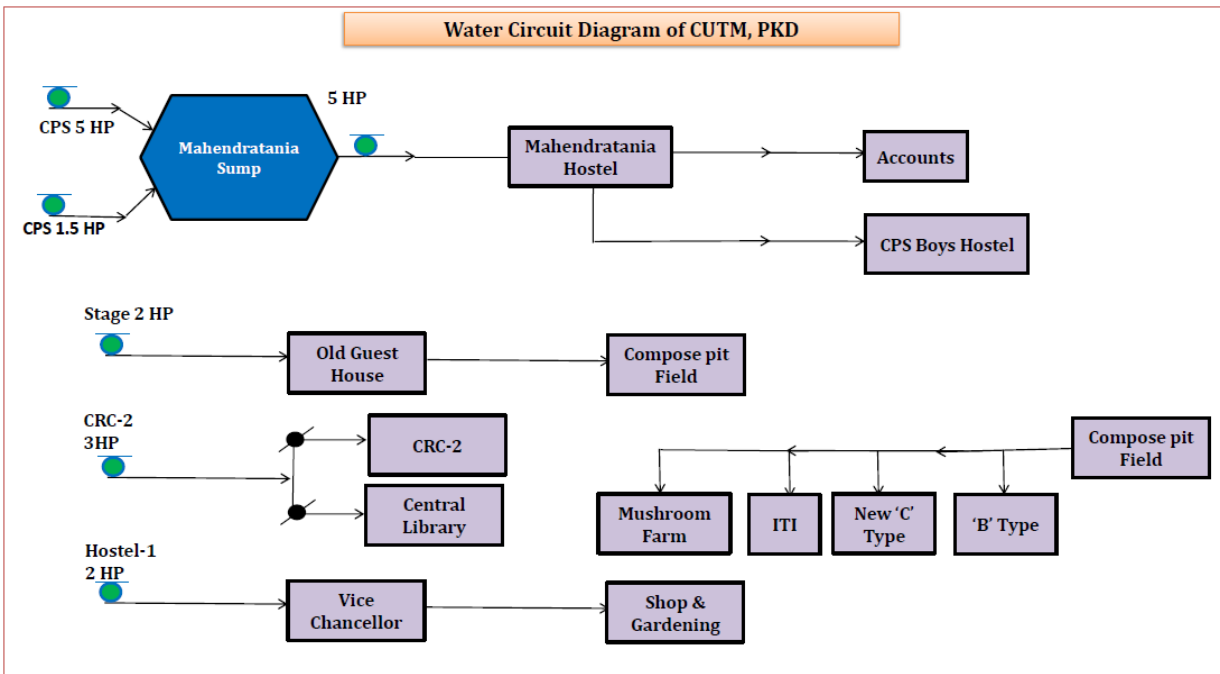
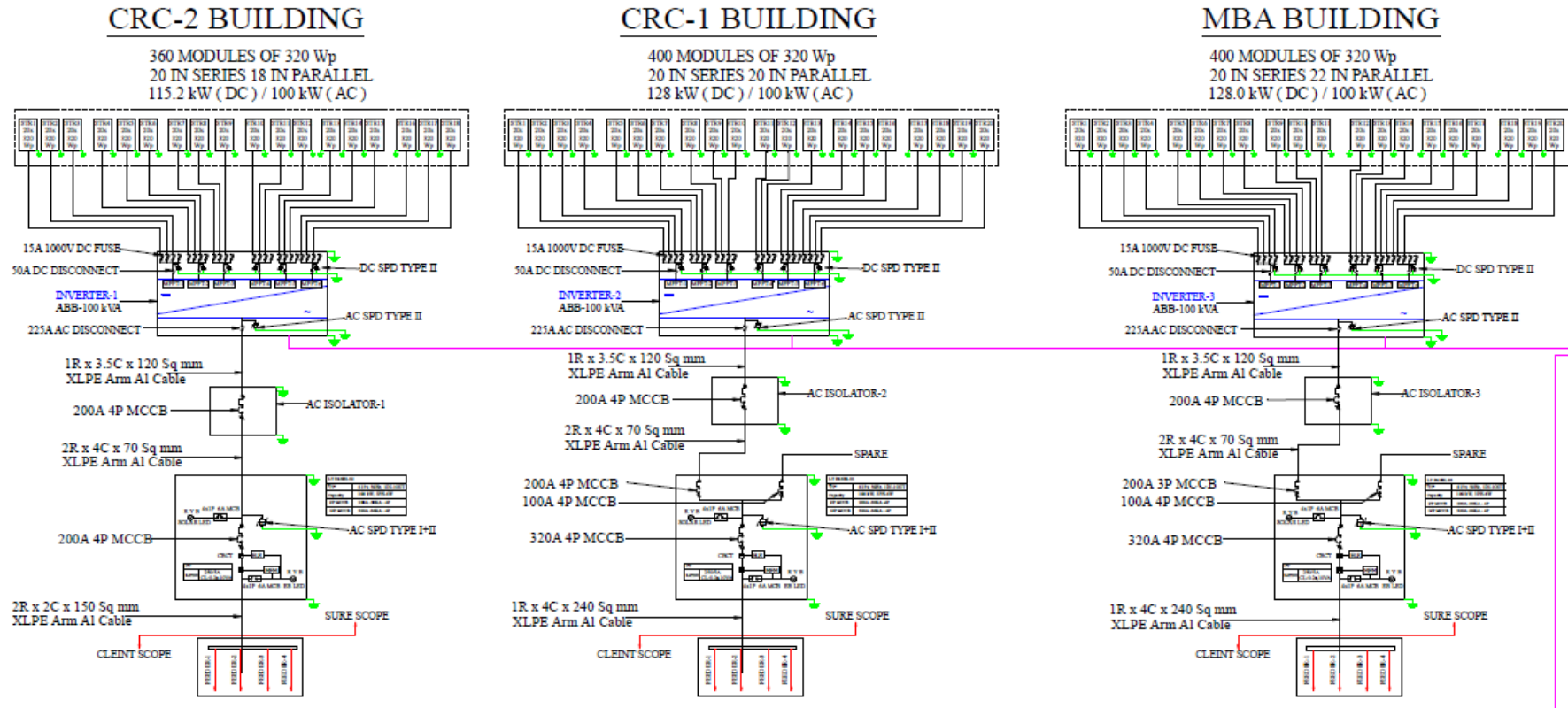



Figure 12: SLD of Solar Distribution System





ITI AND DIPLOMA BUILDING

200 MODULES OF 320 Wp
20 IN SERIES 10 IN PARALLEL
64.0 kW (DC) / 60 kW (AC)

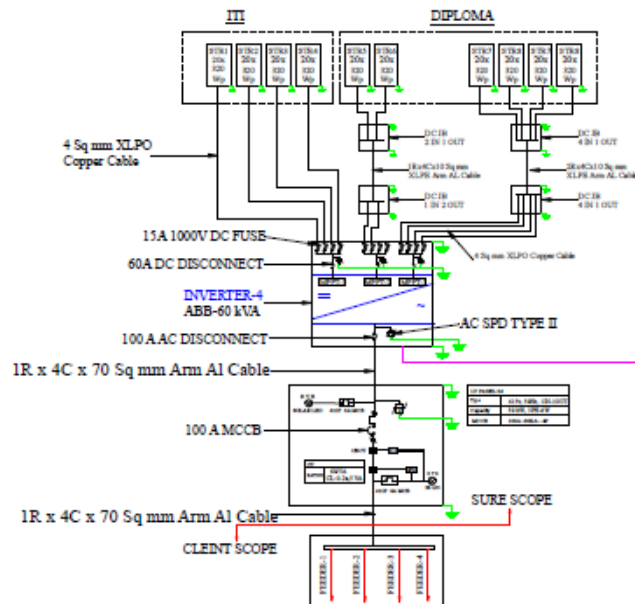

AUDITORIUM

204 MODULES OF 320 Wp
17 IN SERIES 12 IN PARALLEL
65.28 kW (DC) / 60 kW (AC)

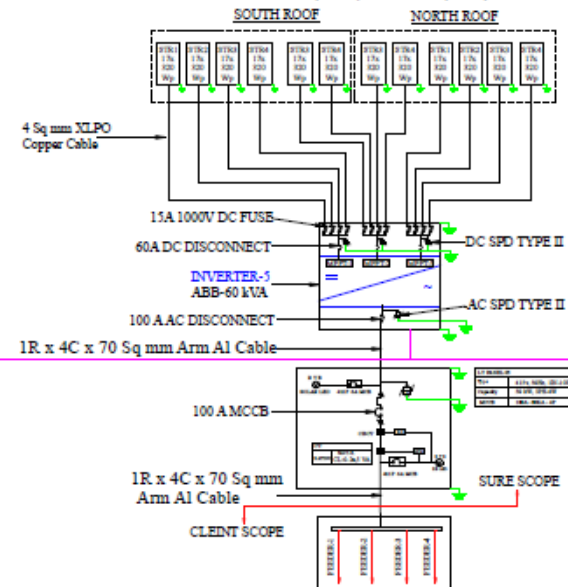



3.4 Transformer Details

The technical specification of transformer and its % loading is furnished below:

Table 12: Technical Specification of Transformer

Technical data sheet of CUTM, Paralakhemundi Transformers				
Particulars	TRF-1	TRF-2	TRF-3	TRF-4
Make	Alfa Transformers Ltd	Alfa Transformers Ltd	Alfa Transformers Ltd	Alfa Transformers Ltd
Transformer rated in kVA	1000.00	500.00	315	250.00
Rated voltage ratio in kV	33/11	11/0.433	11/0.433	11/0.434
Rated current ratio in Amp	17.49/52.118	26.24/66.68	16.54/420.21	13.12/333.34
No. of phase	3.00	3.00	3.00	3.00
Vector diagram	Dyn-11	Dyn-11	Dyn-11	Dyn-11
Type of cooling	ONAN	ONAN	ONAN	ONAN

The power measurement of each transformer is carried out by 3 phase power analyzer. The results are attached in Annexure. Based on Average Power measurement data the transformer loadings and efficiency are calculated and furnished below.

Table 13: Transformer Performance Assessment

Transformer Performance Assessment				
Details	Main TRF	TRF-1	TRF-2	TRF-3
Transformer Rating in KVA	1000.00	500.00	315	250.00
Measured voltage at LT side in kV	0.33	0.41	0.39	0.41
Measured current in LT Side Amp	3.50	50.59	40.09	32.57
No Load Loss (kW)	1.40	0.95	0.95	0.64
Full Load Loss of Transformer (kW)	13.30	6.45	6.45	4.45
Measured load (kVA)	2.00	35.56	27.13	23.11
% Loading on the Transformer (Measured kVA/ Rated kVA)	0.20%	7.11%	8.61%	9.24%



Investment Grade Energy Audit of CUTM, Paralakhemundi

Actual Losses of Transformer (kW)	1.40	0.95	0.95	0.64
Operating Power Factor	0.89	0.89	0.96	0.42
Total Actual Power Delivered by Transformer in kW	1.78	31.65	26.00	9.69
Transformer Efficiency, %	55.98%	97.09%	96.47%	93.81%
Transformer performance	Not satisfactory	Satisfactory	Satisfactory	Satisfactory

Power measurement was carried out at the various outgoing cable emanating from the distribution board of each transformer and the results are tabulated below.

3.5 Study of Voltage, Current, Power Factor Profile

Trend of Output voltage profile, Current profile, Output Power profile, Power Factor profile, Voltage Unbalance of Load Distribution is furnished below.



Table 14: Voltage Variation and % Unbalance of Load Distribution

POWER									
SL. No.	Area	Incoming/Outgoing	Phase	Voltage in (V)	Current in (A)	PF	kW	Unbalance Voltage (V) in %	Unbalance Current (I) in %
1	M B A- Building 1 st Floor	Outgoing	R	232.5	12.1	0.64	7.59	0.00%	47.56%
			Y	232.5	8.1	0.83			
			B	232.5	4.4	0.83			
2	2nd Floor	Outgoing	R	232.5	2.3	0.83	1.96	0.00%	38.98%
			Y	232.5	2.4	0.82			
			B	232.5	1.2	0.83			
3	3rd Floor	Outgoing	R	232.5	9.3	0.83	10.29	0.00%	12.01%
			Y	232.5	10	0.83			
			B	232.5	11.5	0.83			
4	CRC-1,Building (A)	Outgoing	R	225.4	5.1	0.97	5.42	0.00%	12.50%
			Y	225.4	5.1	0.96			
			B	225.4	4.2	0.96			
5	CRC-1(B)	Outgoing	R	233.7	4	0.82	8.05	0.04%	111.45%
			Y	233.5	2.7	0.82			
			B	233.6	16	0.99			
6	CRC-2 Building	Outgoing	R	233.7	8.3	0.91	5.16	0.00%	76.60%
			Y	233.7	2.4	0.81			
			B	233.7	3.4	0.99			
7	Central Library	Outgoing	R	218	7.8	0.88	6.09	3.54%	38.46%
			Y	230	5.5	0.92			



Investment Grade Energy Audit of CUTM, Paralakhemundi

			B	230	3.6	0.96			
8	Boys Hostel-1	Outgoing	R	214.7	13.6	0.99	16.26	2.85%	23.61%
			Y	224.5	17.8	0.99			
			B	223.8	11.8	0.97			
9	Boys Hostel-2 (Rusikulya)	Outgoing	R	221.2	6.4	0.99	8.98	0.06%	48.12%
			Y	221.4	11.8	0.99			
			B	221.2	5.7	0.96			
10	Boys Hostel-4 (Nagabali)	Outgoing	R	222.3	10.1	0.99	10.90	0.08%	14.58%
			Y	222.1	10.5	0.98			
			B	222	8.2	0.98			
11	Boys Hostel-5	Outgoing	R	213.9	10.8	0.99	9.97	4.35%	29.93%
			Y	222.6	6.4	0.97			
			B	204.3	10.2	0.99			
12	CPS Boys Hostel	Outgoing	R	224.2	8.3	0.99	10.52	2.46%	18.93%
			Y	219.4	8.6	0.99			
			B	213.7	11.1	0.99			
13	HPCL Boys Hostel	Outgoing	R	234.5	2.1	0.99	2.62	1.39%	75.38%
			Y	232.7	3.8	0.99			
			B	238.5	0.6	0.99			
14	Boys Hostel (Ramagiri)	Outgoing	R	238.1	9.5	0.92	9.03	1.24%	24.12%
			Y	233.9	6.5	0.78			
			B	238.5	9.7	0.87			
15	Girl Hostel (Indrabati)	Outgoing	R	208.5	12.9	99	806.06	3.70%	16.22%
			Y	205.1	9.4	99			
			B	218.5	11	0.99			



Investment Grade Energy Audit of CUTM, Paralakhemundi

16	Girl Hostel (Mahendrasthanaya)	Outgoing	R	222.5	20	1	65.92	2.28%	139.11%
			Y	223.4	139	0.99			
			B	215.4	15.4	0.98			
17	Girl Hostel (Brahihani)	Outgoing	R	239.2	2.5	0.97	3.43	1.53%	20.69%
			Y	232.1	2.7	0.95			
			B	235.8	3.5	0.98			



Table 15: Voltage Variation and %Unbalance of 500 kVA Transformer- JITM

Voltage Variation and %Unbalance of 500 kVA Transformer- JITM						
Date	Time	Frequency	Phase-1 RMS	Phase-2 RMS	Phase-3 RMS	Vunb
		Hz	V	V	V	%
1/5/2022	11:05:00 AM	49.92	402	403.1	409.4	1.1
1/5/2022	11:06:00 AM	49.93	401.9	402.4	408.4	0.9
1/5/2022	11:07:00 AM	49.91	401.7	402.7	408	0.9
1/5/2022	11:08:00 AM	49.91	401.3	402.8	407.5	0.8
1/5/2022	11:09:00 AM	49.92	401.1	402.9	407.6	0.9
1/5/2022	11:10:00 AM	49.95	402.1	404.2	408.3	0.8
1/5/2022	11:11:00 AM	49.97	403.6	405.1	409.8	0.8
1/5/2022	11:12:00 AM	49.95	401.8	403.7	408.7	0.9
1/5/2022	11:13:00 AM	49.94	402.1	404.4	410	1.1
1/5/2022	11:14:00 AM	49.93	403.1	405.3	410.9	1.1
1/5/2022	11:15:00 AM	49.92	403.1	405.7	410.9	1
1/5/2022	11:16:00 AM	49.91	404.3	406.6	412	1
1/5/2022	11:17:00 AM	49.9	406.3	408.3	413.9	1
1/5/2022	11:18:00 AM	49.92	406.5	408.1	413.6	1
Average Voltage & %Unbalance			405.85			1.0

Figure 13: Trend of Voltage Variation and %Unbalance of 500 kVA Transformer- JITM

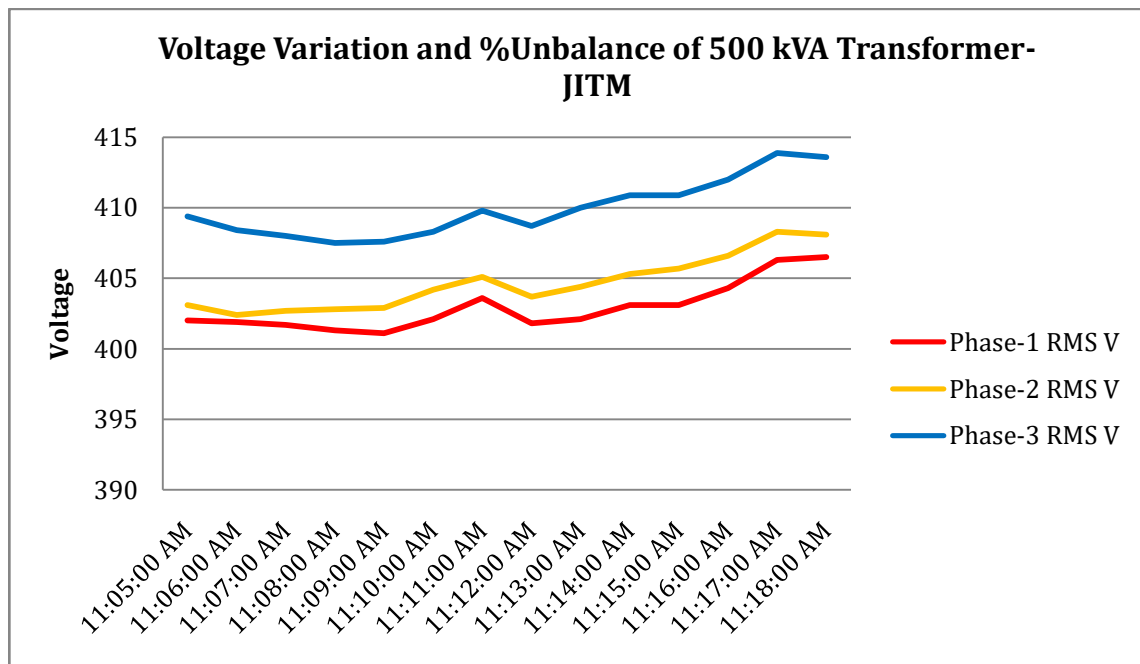



Table 16: Current Variation and %Unbalance of 500 kVA Transformer- JITM

Current Variation and %Unbalance of 500 kVA Transformer -JITM						
Date	Time	Frequency	A1 RMS	A2 RMS	A3 RMS	Aunb
		Hz	A	A	A	%
1/5/2022	11:05:00 AM	49.92	60.7	52.3	57.1	6.6
1/5/2022	11:06:00 AM	49.93	61.6	40.4	49.5	15.3
1/5/2022	11:07:00 AM	49.91	59.5	44.5	46.6	12.3
1/5/2022	11:08:00 AM	49.91	56.7	44.5	45.6	11.6
1/5/2022	11:09:00 AM	49.92	55	46.5	49.6	7.4
1/5/2022	11:10:00 AM	49.95	55.1	46.6	48.7	7.9
1/5/2022	11:11:00 AM	49.97	56.1	55.6	46	9.8
1/5/2022	11:12:00 AM	49.95	54	50.8	41.4	13
1/5/2022	11:13:00 AM	49.94	50.8	47.1	45.4	6.7
1/5/2022	11:14:00 AM	49.93	52	57.2	53.4	4.6
1/5/2022	11:15:00 AM	49.92	54.2	50.6	53.5	3.9
1/5/2022	11:16:00 AM	49.91	54.3	39.4	53.5	12.6
1/5/2022	11:17:00 AM	49.9	51.8	38.8	54.1	13.9
1/5/2022	11:18:00 AM	49.92	48.5	41.5	54.2	11.4
Average Current & %Unbalance			50.70			9.8

Figure 14: Trend of Current Variation and %Unbalance of 500 kVA Transformer- JITM

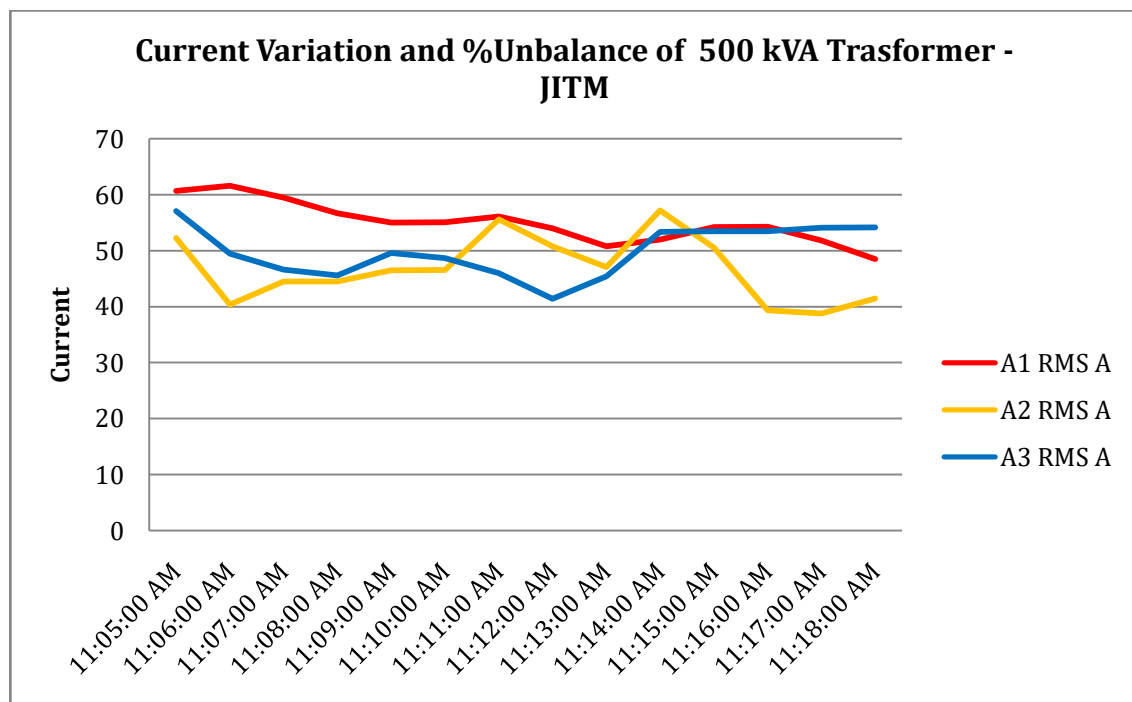



Table 17: Average Power Factor of 500 kVA Transformer -JITM

Average Power Factor of 500 kVA Transformer -JITM						
Date	Time	Frequency	PF1	PF2	PF3	PF Mean
		Hz	Ph-1	Ph-2	Ph-3	Avg.
1/5/2022	11:05:00 AM	49.92	0.95	0.92	0.87	0.912
1/5/2022	11:06:00 AM	49.93	0.94	0.81	0.83	0.861
1/5/2022	11:07:00 AM	49.91	0.93	0.86	0.82	0.87
1/5/2022	11:08:00 AM	49.91	0.94	0.89	0.81	0.881
1/5/2022	11:09:00 AM	49.92	0.93	0.89	0.86	0.894
1/5/2022	11:10:00 AM	49.95	0.93	0.89	0.85	0.888
1/5/2022	11:11:00 AM	49.97	0.94	0.93	0.84	0.903
1/5/2022	11:12:00 AM	49.95	0.93	0.92	0.79	0.878
1/5/2022	11:13:00 AM	49.94	0.93	0.91	0.84	0.893
1/5/2022	11:14:00 AM	49.93	0.93	0.94	0.87	0.912
1/5/2022	11:15:00 AM	49.92	0.94	0.92	0.88	0.914
1/5/2022	11:16:00 AM	49.91	0.93	0.86	0.88	0.889
1/5/2022	11:17:00 AM	49.9	0.92	0.85	0.88	0.883
1/5/2022	11:18:00 AM	49.92	0.92	0.85	0.88	0.882
Average Power Factor						0.89

Figure 15: Trend of Power Factor of 500 kVA Transformer -JITM

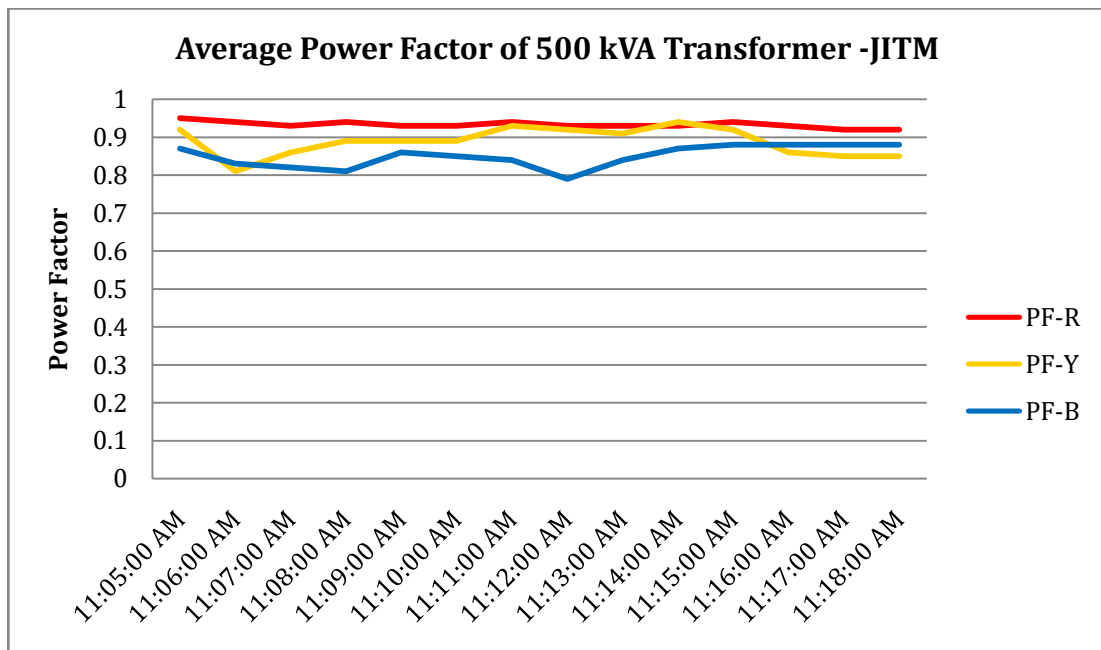



Table 18: Snapshot of Load in (W & VA) of 500 kVA Transformer-JITM

Snapshot of Load in (W & VA) of 500 kVA Transformer-JITM				
Date	Time	Frequency	Watt Total	Volt Amp Total
		Hz	W	VA
1/5/2022	11:05:00 AM	49.92	36347.5	39804.1
1/5/2022	11:06:00 AM	49.93	30912.8	35451
1/5/2022	11:07:00 AM	49.91	30818.7	35167.8
1/5/2022	11:08:00 AM	49.91	30229.8	34290.3
1/5/2022	11:09:00 AM	49.92	31581.3	35267.7
1/5/2022	11:10:00 AM	49.95	31369.1	35215.3
1/5/2022	11:11:00 AM	49.97	33622.2	37029.4
1/5/2022	11:12:00 AM	49.95	30330.6	34224.7
1/5/2022	11:13:00 AM	49.94	30034.1	33567.7
1/5/2022	11:14:00 AM	49.93	34876	38177
1/5/2022	11:15:00 AM	49.92	34042.6	37206.7
1/5/2022	11:16:00 AM	49.91	31028	34731.8
1/5/2022	11:17:00 AM	49.9	30380.1	34276
1/5/2022	11:18:00 AM	49.92	30286.5	34158.3
Average			31847	35612

Figure 16: Trend of Load & VA of 500 kVA Transformer-JITM

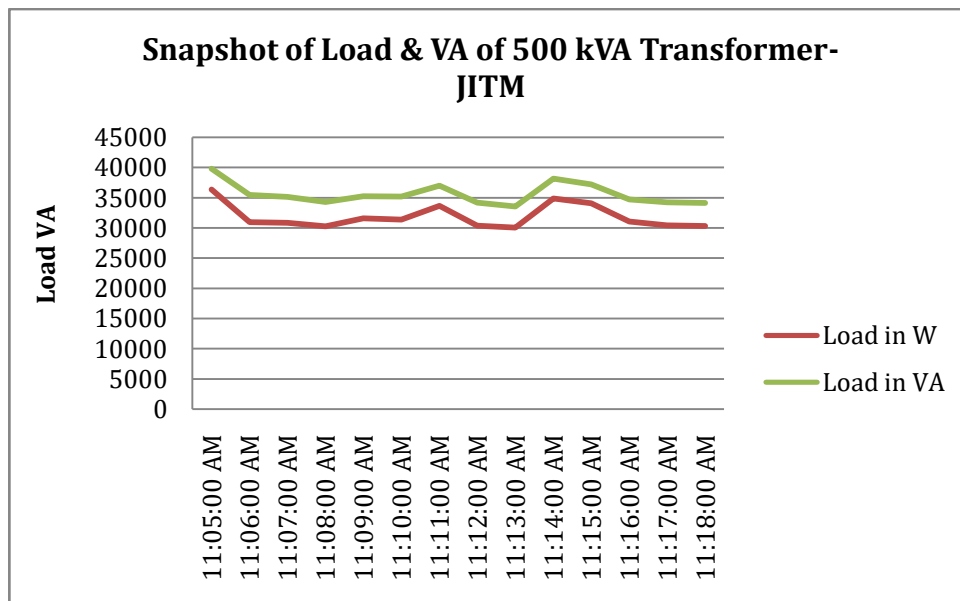



Table 19: Voltage Variation and %Unbalance of 315 kVA ,ITI Transformer

Voltage Variation and %Unbalance of 315 kVA ,ITI Transformer						
Date	Time	Frequency	Phase-1 RMS	Phase-2 RMS	Phase-3 RMS	Vunb
		Hz	V	V	V	%
1/5/2022	12:27:00 PM	49.9	388.4	393	386.1	1
1/5/2022	12:28:00 PM	49.9	388.3	392.8	385.9	0.9
1/5/2022	12:29:00 PM	49.92	388.4	393.4	386.1	1
1/5/2022	12:30:00 PM	49.97	389	394	386.9	1
1/5/2022	12:31:00 PM	49.99	389.8	394.9	387.5	1
1/5/2022	12:32:00 PM	49.98	389	394.9	386.8	1.1
1/5/2022	12:33:00 PM	49.97	389.7	395.4	386.8	1.2
1/5/2022	12:34:00 PM	49.97	389.9	395.3	386.6	1.2
1/5/2022	12:35:00 PM	49.96	388.2	394.3	386.2	1.2
1/5/2022	12:36:00 PM	49.96	388.6	394.8	386.8	1.1
1/5/2022	12:37:00 PM	49.96	388.6	394.8	386.9	1.1
1/5/2022	12:38:00 PM	49.95	389	395.1	387.3	1.1
1/5/2022	12:39:00 PM	49.96	389.5	395.8	387.7	1.2
1/5/2022	12:40:00 PM	49.97	390.6	396.3	388.4	1.1
1/5/2022	12:41:00 PM	49.96	390.7	396.4	388.3	1.1
1/5/2022	12:42:00 PM	49.97	391.1	397.1	388.5	1.2
1/5/2022	12:43:00 PM	49.98	391.4	397.4	389.2	1.2
1/5/2022	12:44:00 PM	50.03	393.4	399.3	390.6	1.2
Average Voltage & %Unbalance			391			1.11



Figure 17: Trend of Voltage Variation and %Unbalance of 315 kVA, ITI Transformer

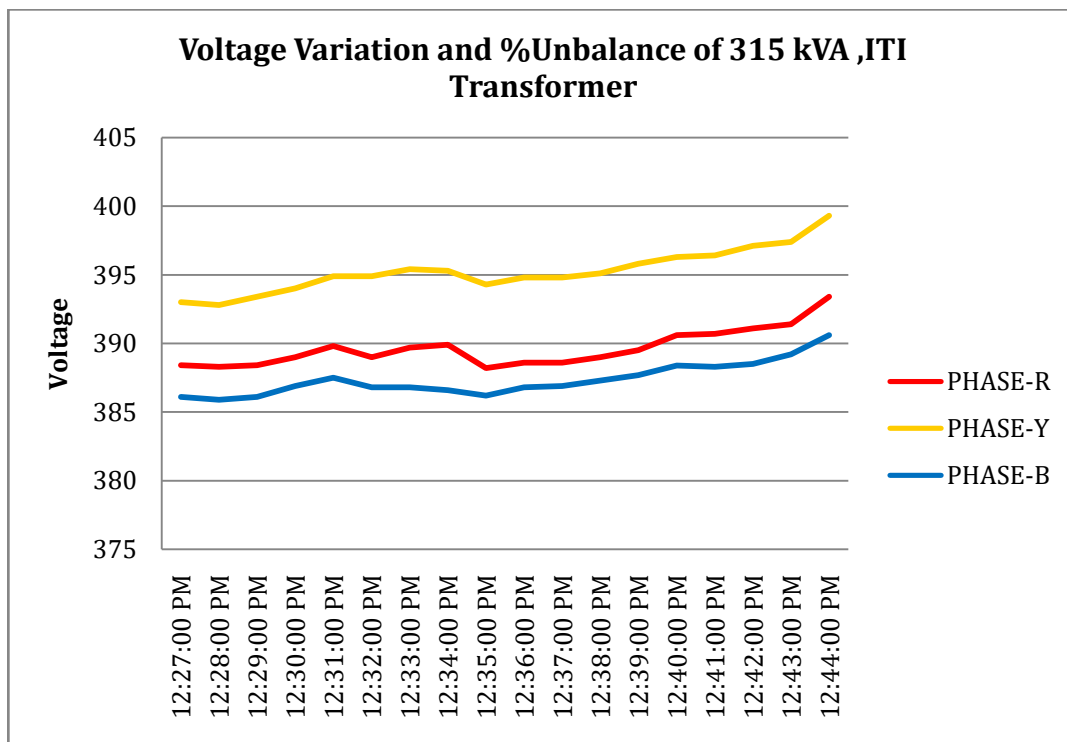

Table 20: Current Variation and %Unbalance of 315 kVA, ITI Transformer

Current Variation and %Unbalance of 315 kVA, ITI Transformer						
Date	Time	Frequency	A1 RMS	A2 RMS	A3 RMS	Aunb
		Hz	A	A	A	%
1/5/2022	12:27:00 PM	49.9	45.1	39.4	36.6	10.2
1/5/2022	12:28:00 PM	49.9	45.2	39.2	36.8	10.6
1/5/2022	12:29:00 PM	49.92	45.5	38.6	35.8	10.9
1/5/2022	12:30:00 PM	49.97	49.7	43.2	39.5	9.4
1/5/2022	12:31:00 PM	49.99	49	43.1	38.8	9.4
1/5/2022	12:32:00 PM	49.98	49.4	42	39.2	9.1
1/5/2022	12:33:00 PM	49.97	49.2	42.3	36.5	14.2
1/5/2022	12:34:00 PM	49.97	47.4	38.1	29.7	23.5
1/5/2022	12:35:00 PM	49.96	42.4	35.4	33.3	11.2
1/5/2022	12:36:00 PM	49.96	43.3	36.3	33.2	12
1/5/2022	12:37:00 PM	49.96	48.2	41.7	38.3	10
1/5/2022	12:38:00 PM	49.95	48.3	41.9	38.4	9.5



1/5/2022	12:39:00 PM	49.96	48.1	42	38.4	8.8
1/5/2022	12:40:00 PM	49.97	46	40.7	36.9	9.3
1/5/2022	12:41:00 PM	49.96	40.9	35.4	33	12
1/5/2022	12:42:00 PM	49.97	37.4	34.9	31.7	10.2
1/5/2022	12:43:00 PM	49.98	36.9	33.2	33.4	10.6
1/5/2022	12:44:00 PM	50.03	40.8	36.6	38.3	9.6
Average Current & %Unbalance			40.1			11.1

Figure 18: Trend of Current Variation and %Unbalance of 315 kVA, ITI Transformer

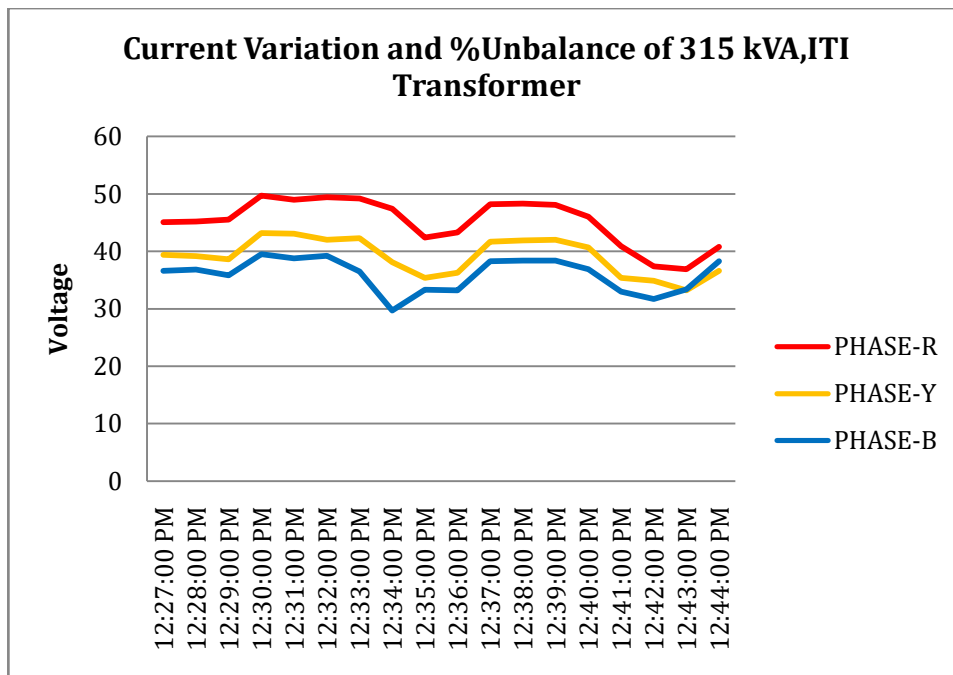

Table 21: Average Power Factor of 315 kVA, ITI Transformer

Average Power Factor of 315 kVA ,ITI Transformer						
Date	Time	Frequency	PF1	PF2	PF3	PF Mean
		Hz	Ph-1	Ph-2	Ph-3	Avg.
1/5/2022	12:27:00 PM	49.9	0.98	0.99	0.93	0.966
1/5/2022	12:28:00 PM	49.9	0.98	0.99	0.92	0.963
1/5/2022	12:29:00 PM	49.92	0.98	0.98	0.93	0.965
1/5/2022	12:30:00 PM	49.97	0.99	0.99	0.94	0.973
1/5/2022	12:31:00 PM	49.99	0.98	0.99	0.95	0.972
1/5/2022	12:32:00 PM	49.98	0.99	0.99	0.94	0.972
1/5/2022	12:33:00 PM	49.97	0.99	0.97	0.93	0.961
1/5/2022	12:34:00 PM	49.97	0.98	0.93	0.9	0.937



1/5/2022	12:35:00 PM	49.96	0.98	0.97	0.9	0.948
1/5/2022	12:36:00 PM	49.96	0.98	0.98	0.92	0.96
1/5/2022	12:37:00 PM	49.96	0.99	0.99	0.94	0.97
1/5/2022	12:38:00 PM	49.95	0.99	0.99	0.94	0.97
1/5/2022	12:39:00 PM	49.96	0.99	0.99	0.94	0.97
1/5/2022	12:40:00 PM	49.97	0.98	0.98	0.94	0.965
1/5/2022	12:41:00 PM	49.96	0.98	0.98	0.88	0.945
1/5/2022	12:42:00 PM	49.97	0.97	0.98	0.91	0.953
1/5/2022	12:43:00 PM	49.98	0.92	0.96	0.93	0.936
1/5/2022	12:44:00 PM	50.03	0.95	0.98	0.94	0.957
Average Power Factor						1.0

Figure 19: Trend of Power Factor of 315 kVA, ITI Transformer

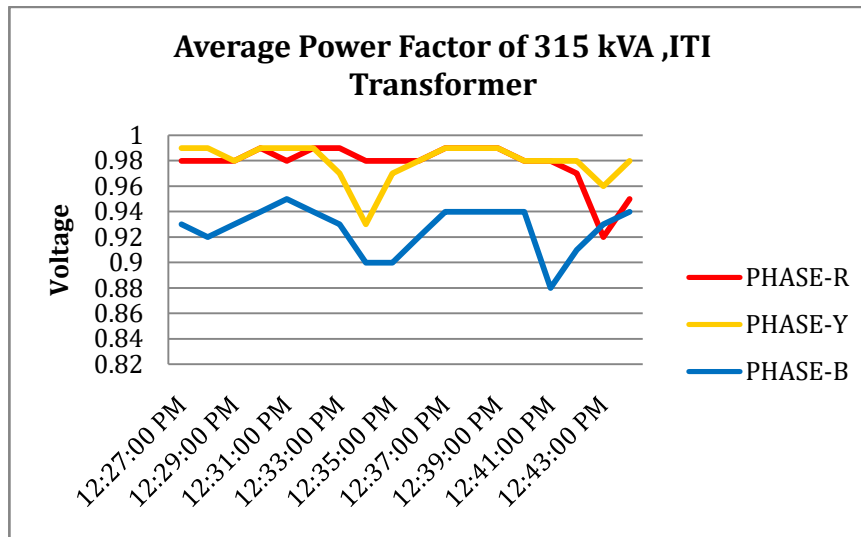

Table 22: Snapshot of Load in (W & VA) of 315 kVA ITI Transformer

Snapshot of Load in (W & VA) of 315 kVA ITI Transformer				
Date	Time	Frequency	Watt Total	Volt Amp Total
		Hz	W	VA
1/5/2022	12:27:00 PM	49.9	26346.9	27219.4
1/5/2022	12:28:00 PM	49.9	26301.3	27246
1/5/2022	12:29:00 PM	49.92	26080.3	26960.5
1/5/2022	12:30:00 PM	49.97	29095.5	29825.1
1/5/2022	12:31:00 PM	49.99	28781.4	29558.3
1/5/2022	12:32:00 PM	49.98	28672.4	29438.3
1/5/2022	12:33:00 PM	49.97	27874.2	28883.7



1/5/2022	12:34:00 PM	49.97	24521.7	26008.8
1/5/2022	12:35:00 PM	49.96	23806.1	25015.2
1/5/2022	12:36:00 PM	49.96	24485	25419.5
1/5/2022	12:37:00 PM	49.96	28070.1	28891.9
1/5/2022	12:38:00 PM	49.95	28196.9	29007.2
1/5/2022	12:39:00 PM	49.96	28234.7	29029.5
1/5/2022	12:40:00 PM	49.97	27081.9	27991.9
1/5/2022	12:41:00 PM	49.96	23483.5	24767.8
1/5/2022	12:42:00 PM	49.97	22520.6	23581.8
1/5/2022	12:43:00 PM	49.98	21988.5	23487
1/5/2022	12:44:00 PM	50.03	25247.8	26368.8
Average			26154.93	27150.04

Figure 20: Trend of Load, & VA of 315 kVA, ITI Transformer

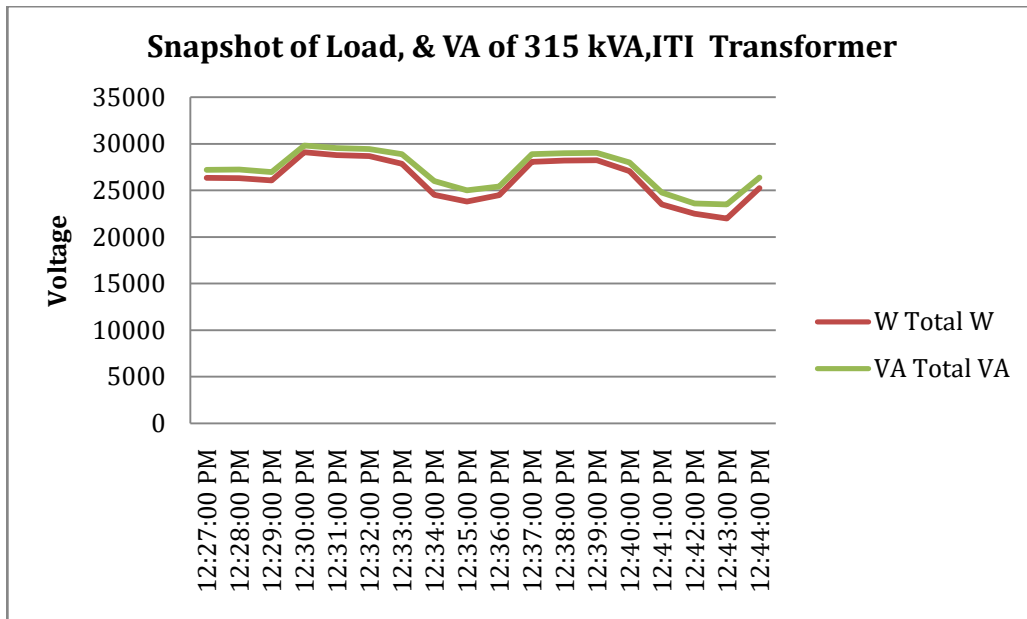

Table 23: Voltage Variation and %Unbalance of 250 kVA Transformer- MBA

Voltage Variation and %Unbalance of 250 kVA Transformer- MBA						
Date	Time	Frequency	Phase-1 RMS	Phase-2 RMS	Phase-3 RMS	Vunb
		Hz	V	V	V	%
1/5/2022	1:10:00 PM	49.98	413.2	405.6	408.2	1
1/5/2022	1:11:00 PM	50	412.5	405.7	407.7	0.9
1/5/2022	1:12:00 PM	50.01	412.8	406.7	408.1	0.8
1/5/2022	1:13:00 PM	50.01	413.7	407.6	409	0.8
1/5/2022	1:14:00 PM	50.02	413.8	407.4	408.6	0.9



Investment Grade Energy Audit of CUTM, Paralakhemundi

1/5/2022	1:15:00 PM	50	413.8	407.6	408.9	0.8
1/5/2022	1:16:00 PM	49.99	413	406.5	408.1	0.9
1/5/2022	1:17:00 PM	50.01	412.7	406	407.9	0.9
1/5/2022	1:18:00 PM	50.03	411.8	405.9	406.4	0.8
1/5/2022	1:19:00 PM	50	412.9	406.6	407	0.9
1/5/2022	1:20:00 PM	50	413.9	406.9	408.8	0.9
1/5/2022	1:21:00 PM	50.02	415.3	407.8	409.5	1
1/5/2022	1:22:00 PM	50.01	414.8	407.2	408.9	1
1/5/2022	1:23:00 PM	49.99	414.1	406.8	408.4	1
1/5/2022	1:24:00 PM	50	413.3	406.3	408	0.9
1/5/2022	1:25:00 PM	49.98	412.7	406.3	407.8	0.9
1/5/2022	1:26:00 PM	49.98	412	406.5	407.4	0.7
1/5/2022	1:27:00 PM	49.99	412.2	407.1	406.7	0.8
1/5/2022	1:28:00 PM	49.98	412.3	406.5	406.4	0.9
1/5/2022	1:29:00 PM	50.01	412.9	407	406.8	0.9
1/5/2022	1:30:00 PM	50.03	412	406.5	406.8	0.8
1/5/2022	1:31:00 PM	50.03	412.7	406.8	407.8	0.8
1/5/2022	1:32:00 PM	50.03	413.8	406.8	408.9	0.9
1/5/2022	1:33:00 PM	50	413.6	406.8	408.7	0.9
1/5/2022	1:34:00 PM	50	414.5	407.6	408.6	1
1/5/2022	1:35:00 PM	50	417	409.7	410.3	1.1
1/5/2022	1:36:00 PM	50.02	415.9	408.5	409.3	1.1
1/5/2022	1:37:00 PM	50.02	416.1	408.8	409.6	1
1/5/2022	1:38:00 PM	50.03	415.5	408.4	409.3	1
1/5/2022	1:39:00 PM	50.02	415.7	408.2	409.2	1.1
Average Voltage & %Unbalance			409.5			0.91



Figure 21: Trend of Voltage Variation and %Unbalance of 250 kVA Transformer- MBA

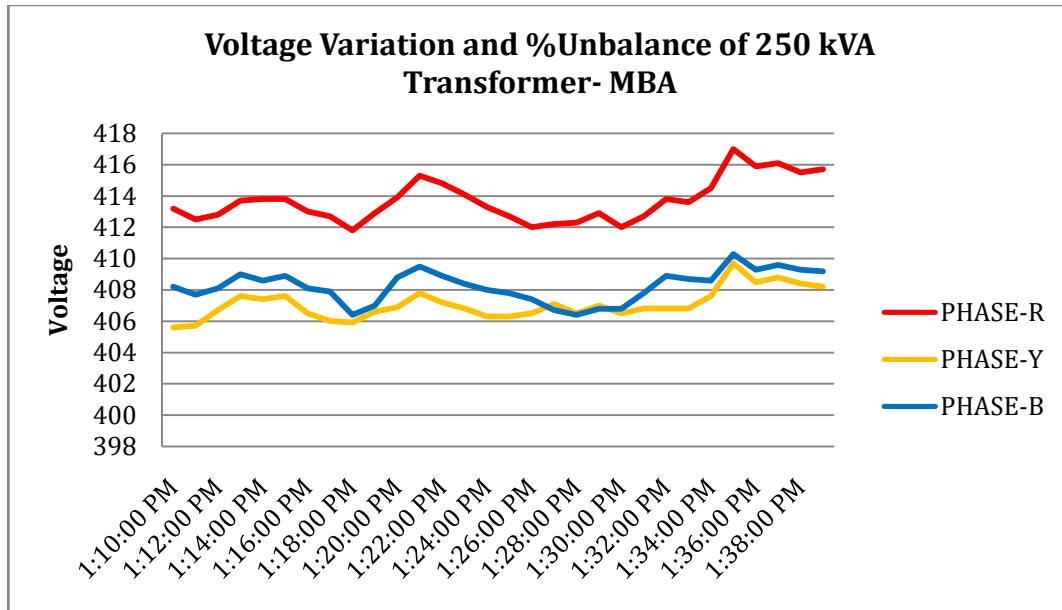

Table 24: Current Variation and %Unbalance of 250 kVA Transformer- MBA

Current Variation and %Unbalance of 250 kVA Transformer- MBA						
Date	Time	Frequency	A1 RMS	A2 RMS	A3 RMS	Aunb
		Hz	A	A	A	%
1/5/2022	1:10:00 PM	49.98	32.6	19.7	32.8	15.7
1/5/2022	1:11:00 PM	50	33.9	23.1	33.5	11.1
1/5/2022	1:12:00 PM	50.01	33.9	25.2	33.5	8
1/5/2022	1:13:00 PM	50.01	33.4	24.5	32.7	8.4
1/5/2022	1:14:00 PM	50.02	32.9	24.1	31.9	8.2
1/5/2022	1:15:00 PM	50	32	27.6	31.8	3.7
1/5/2022	1:16:00 PM	49.99	32.2	29.5	31.9	2.3
1/5/2022	1:17:00 PM	50.01	32.2	29.2	31.7	2.5
1/5/2022	1:18:00 PM	50.03	31.9	29.2	31.7	1.7
1/5/2022	1:19:00 PM	50	39.4	36.8	39	1
1/5/2022	1:20:00 PM	50	39.4	36.3	38.6	1.5
1/5/2022	1:21:00 PM	50.02	38.9	36.7	39	1.1
1/5/2022	1:22:00 PM	50.01	38.7	36.7	39	1.2
1/5/2022	1:23:00 PM	49.99	38.9	37.4	38.3	2.2
1/5/2022	1:24:00 PM	50	39.5	37	38.7	1.7



Investment Grade Energy Audit of CUTM, Paralakhemundi

1/5/2022	1:25:00 PM	49.98	39.1	36.6	38.7	1.4
1/5/2022	1:26:00 PM	49.98	38	35.8	37.9	1
1/5/2022	1:27:00 PM	49.99	37.4	30.9	37.3	6.6
1/5/2022	1:28:00 PM	49.98	37.2	31.9	37.4	5.1
1/5/2022	1:29:00 PM	50.01	31.9	29.6	34.7	6.6
1/5/2022	1:30:00 PM	50.03	30	33.4	33.4	8
1/5/2022	1:31:00 PM	50.03	30.8	32.5	32.9	6.8
1/5/2022	1:32:00 PM	50.03	30.9	27.7	31.7	3.9
1/5/2022	1:33:00 PM	50	31.1	32.4	29.4	9
1/5/2022	1:34:00 PM	50	29.9	31.8	27.9	11
1/5/2022	1:35:00 PM	50	29.5	24.1	26.9	2.8
1/5/2022	1:36:00 PM	50.02	30.3	25.6	28.1	2.8
1/5/2022	1:37:00 PM	50.02	29.6	27.3	31	1.8
1/5/2022	1:38:00 PM	50.03	28.8	27.6	31	2.7
1/5/2022	1:39:00 PM	50.02	28.2	25.8	30.6	5.6
Average Current & %Unbalance			32.57			4.8

Figure 22: Trend of Current Variation and %Unbalance of 250 kVA Transformer-MBA

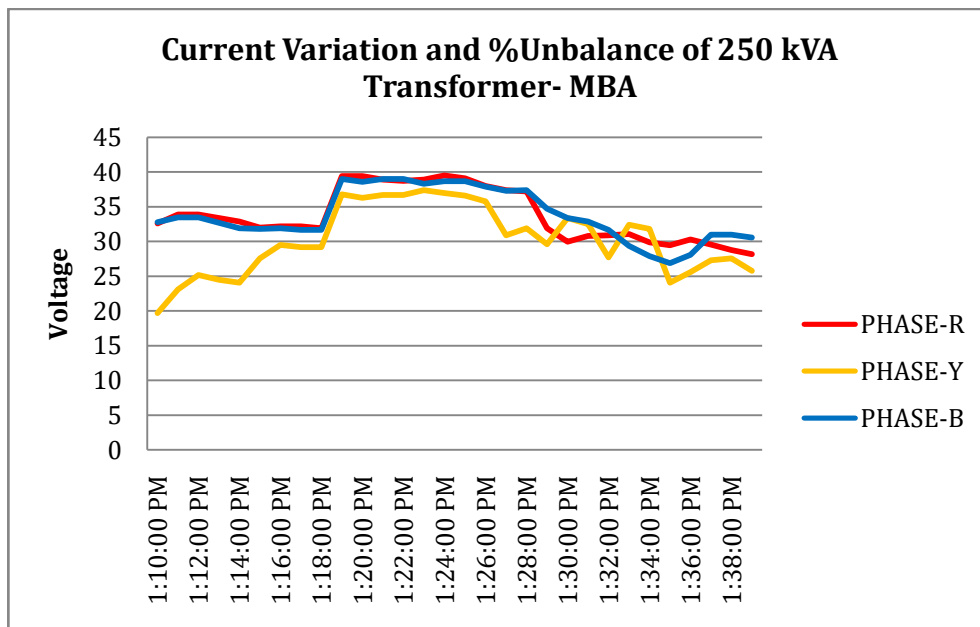



Table 25: Average Power Factor of 250 kVA Transformer- MBA

Average Power Factor of 250 kVA Transformer- MBA						
Date	Time	Frequency	PF1	PF2	PF3	PF Mean
		Hz	Ph-1	Ph-2	Ph-3	Avg.
1/5/2022	1:10:00 PM	49.98	0.35	0.31	0.43	0.363
1/5/2022	1:11:00 PM	50	0.4	0.38	0.46	0.41
1/5/2022	1:12:00 PM	50.01	0.42	0.44	0.48	0.447
1/5/2022	1:13:00 PM	50.01	0.42	0.46	0.48	0.452
1/5/2022	1:14:00 PM	50.02	0.42	0.46	0.48	0.453
1/5/2022	1:15:00 PM	50	0.41	0.46	0.48	0.449
1/5/2022	1:16:00 PM	49.99	0.41	0.47	0.49	0.453
1/5/2022	1:17:00 PM	50.01	0.41	0.47	0.49	0.455
1/5/2022	1:18:00 PM	50.03	0.41	0.46	0.5	0.456
1/5/2022	1:19:00 PM	50	0.41	0.44	0.48	0.444
1/5/2022	1:20:00 PM	50	0.41	0.44	0.47	0.442
1/5/2022	1:21:00 PM	50.02	0.41	0.45	0.47	0.442
1/5/2022	1:22:00 PM	50.01	0.41	0.45	0.47	0.444
1/5/2022	1:23:00 PM	49.99	0.41	0.45	0.48	0.444
1/5/2022	1:24:00 PM	50	0.41	0.45	0.48	0.446
1/5/2022	1:25:00 PM	49.98	0.41	0.45	0.48	0.446
1/5/2022	1:26:00 PM	49.98	0.41	0.45	0.47	0.444
1/5/2022	1:27:00 PM	49.99	0.41	0.27	0.48	0.387
1/5/2022	1:28:00 PM	49.98	0.4	0.28	0.48	0.387
1/5/2022	1:29:00 PM	50.01	0.38	0.35	0.52	0.413
1/5/2022	1:30:00 PM	50.03	0.34	0.4	0.49	0.407
1/5/2022	1:31:00 PM	50.03	0.37	0.41	0.51	0.427
1/5/2022	1:32:00 PM	50.03	0.36	0.3	0.49	0.382
1/5/2022	1:33:00 PM	50	0.36	0.41	0.5	0.425
1/5/2022	1:34:00 PM	50	0.35	0.43	0.5	0.427
1/5/2022	1:35:00 PM	50	0.34	0.31	0.51	0.384
1/5/2022	1:36:00 PM	50.02	0.2	0.19	0.36	0.254
1/5/2022	1:37:00 PM	50.02	0.3	0.38	0.46	0.378
1/5/2022	1:38:00 PM	50.03	0.35	0.44	0.5	0.429
1/5/2022	1:39:00 PM	50.02	0.34	0.34	0.5	0.392
Average Power Factor						0.438



Figure 23: Trend of Power Factor of 250 kVA Transformer- MBA

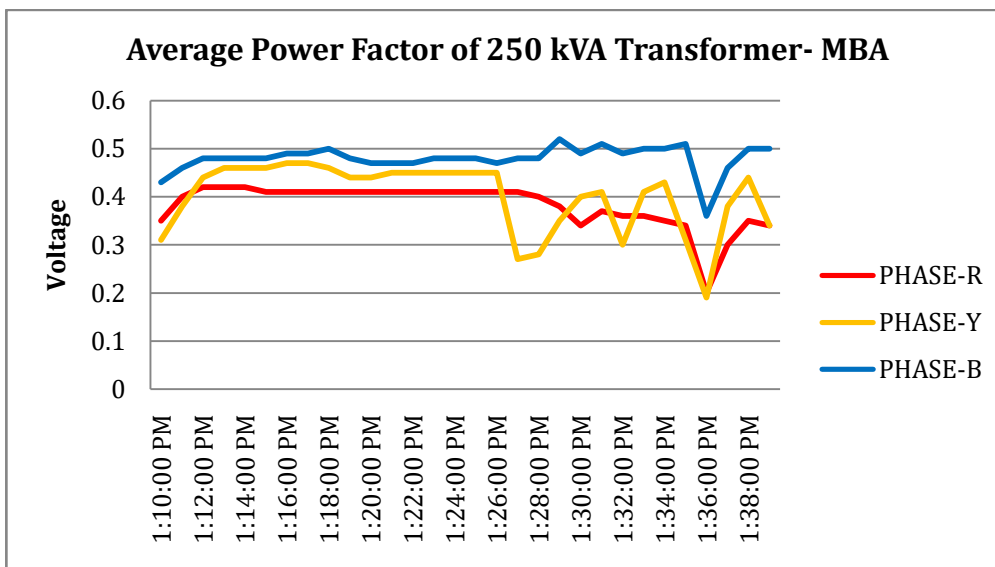

Table 26: Snapshot of Load, var & VA of 250 kVA Transformer- MBA

Snapshot of Load, var & VA of 250 kVA Transformer- MBA					
Date	Time	Frequency	W Total	var Total	VA Total
		Hz	W	var	VA
1/5/2022	1:10:00 PM	49.98	7549.91	-18126.1	20151.5
1/5/2022	1:11:00 PM	50	8872.79	-19357.1	21376.9
1/5/2022	1:12:00 PM	50.01	9806.88	-19550.4	21880
1/5/2022	1:13:00 PM	50.01	9708.1	-19152.3	21479.4
1/5/2022	1:14:00 PM	50.02	9543.23	-18780.3	21075.4
1/5/2022	1:15:00 PM	50	9734.72	-19348.4	21673.7
1/5/2022	1:16:00 PM	49.99	10029.7	-19733.8	22151.1
1/5/2022	1:17:00 PM	50.01	9993.29	-19578.2	21996.8
1/5/2022	1:18:00 PM	50.03	10010.8	-19489.8	21928.1
1/5/2022	1:19:00 PM	50	12089.7	-24367.9	27216.6
1/5/2022	1:20:00 PM	50	11973.8	-24269.4	27073.9
1/5/2022	1:21:00 PM	50.02	12018.8	-24399.7	27212.9
1/5/2022	1:22:00 PM	50.01	12052.3	-24311.4	27148.8
1/5/2022	1:23:00 PM	49.99	12037.8	-24303.1	27135.3
1/5/2022	1:24:00 PM	50	12153.7	-24374.3	27249.6
1/5/2022	1:25:00 PM	49.98	12058.8	-24209.3	27058.7
1/5/2022	1:26:00 PM	49.98	11728.7	-23655.4	26414.6
1/5/2022	1:27:00 PM	49.99	9855.57	-22790	24948.4
1/5/2022	1:28:00 PM	49.98	9869.94	-23032	25148.9



1/5/2022	1:29:00 PM	50.01	9487.37	-20251.8	22741
1/5/2022	1:30:00 PM	50.03	9378.88	-20688.6	22846.7
1/5/2022	1:31:00 PM	50.03	9783.86	-20462.5	22744
1/5/2022	1:32:00 PM	50.03	8272.57	-19662.5	21417
1/5/2022	1:33:00 PM	50	9348.21	-19902.5	22036.2
1/5/2022	1:34:00 PM	50	9063.78	-19185.1	21269.6
1/5/2022	1:35:00 PM	50	7414.61	-17591.6	19190.2
1/5/2022	1:36:00 PM	50.02	5057.12	-19171.2	19965.7
1/5/2022	1:37:00 PM	50.02	7909.92	-19197.2	20896.4
1/5/2022	1:38:00 PM	50.03	8949.96	-18679.1	20763.8
1/5/2022	1:39:00 PM	50.02	7988.2	-18379.7	20117.6
Average			9472.16	-19235.16	21523.66

Figure 24: Trend of Power Factor of 250 kVA Transformer- MBA

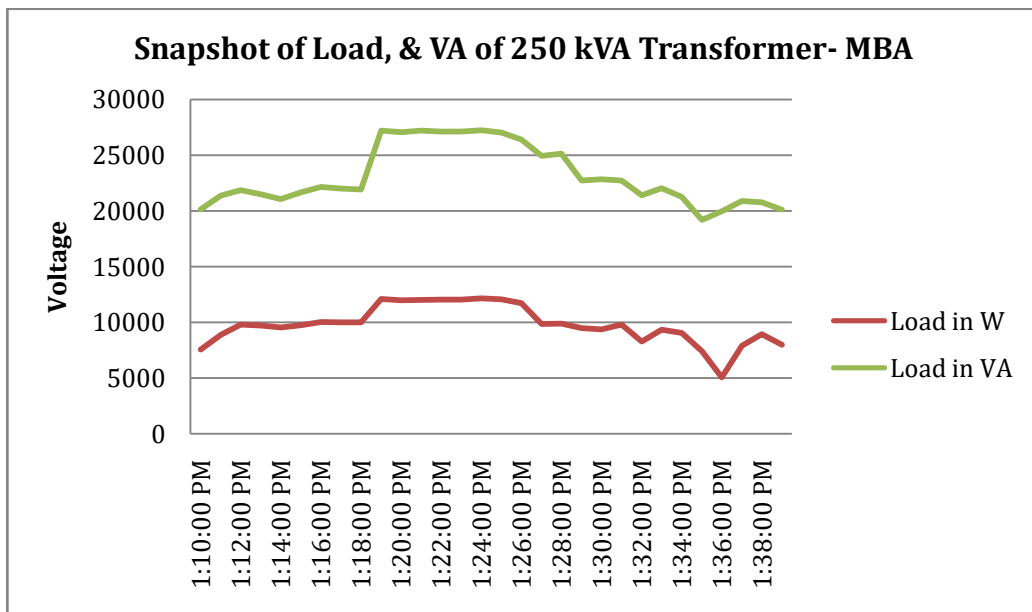



4.0 LIGHTING SYSTEM

4.1 Lighting Inventory

Adequate and proper lighting contributes both directly and indirectly towards productivity and safety, and towards providing an improved work atmosphere. In fact, all these are inter-related and complimentary to each other. There are several factors, which contribute towards proper lighting. However, all efforts were made to study and include these factors during audit of CUTM for lighting loads.

To study, analyze and identify energy conservation options in lighting, a study of the building lighting load was conducted. The purpose of the study was to determine the lighting load and its distribution in various sections of the Building, determine the quality of illumination provided, and recommend measures to improve illumination and reduce electricity consumption.

A high quality and accurate digital lux meter was used to measure the illumination level at various sections of the building during working hours. Other performance indicators such as type of lamps used, type of luminaries, physical condition of lamps and luminaries, use of day lighting, etc. was also noted down.

During the study, measurement of lighting loads, voltage conditions, phase balancing in the facility areas were carried out. The illumination level was also measured primarily at various classrooms and common areas of the building. Care was taken to reduce the effect of day lighting while taking the measurements. The recorded inventory is enclosed in tabular form.

To determine the quantity of lighting load a physical count of the light fittings in CUTM, Paralakhemundi was carried out. Further, the inputs from the officials and maintenance log books were taken into consideration for calculating the inventory of total light fittings of the CUTM. The total connected load of lighting in CUTM is about 143 kW. The summarized lighting installations are furnished below.

Table 27: Total individual lighting calculation of CUTM, Paralakhemundi

Lighting Inventory				
Area Name	Types of Load	Wattage of each load in Watt	Nos. installed	Total connected Wattage in Watt
CRC 1	T5 Tube Light	20	94	1880
	Old Tube Light	40	93	3720
	Round LED	18	48	864
	LED	9	3	27
CRC 2	T5 Tube Light	20	48	960
	Old Tube Light	40	40	1600
	2ft 2 ft LED	36	26	936
	Round LED	18	12	216
	LED	9	21	189



Investment Grade Energy Audit of CUTM, Paralakhemundi

Eicher Lab	T5 Tube Light	20	15	300
	2ft 2 ft LED	36	27	972
Mechanical Workshop Lab	T5 Tube Light	20	4	80
	2ft 2 ft LED	36	25	900
Central Mess 1	T5 Tube Light	20	9	180
	2ft 2 ft LED	36	20	720
Central Mess 2	Old Tube Light	40	4	160
	2ft 2 ft LED	36	12	432
ITI Building	Old Tube Light	40	25	1000
	2ft 2 ft LED	36	20	720
MBA Block	T5 Tube Light	20	186	3720
	2ft 2 ft LED	36	30	1080
Store Office	T5 Tube Light	20	15	300
	LED	9	1	9
Hostel for Tribal students SAIL	T5 Tube Light	20	106	2120
	LED	9	208	1872
	Outdoor LED	50	3	150
Library	T5 Tube Light	20	42	840
	Old Tube Light	40	1	40
	2ft 2 ft LED	36	53	1908
	Round LED	18	3	54
Student Activity Center	T5 Tube Light	20	57	1140
	LED	50	6	300
Boys Hostel 1	T5 Tube Light	20	100	2000
	Round LED	18	9	162
Boys Hostel 2	T5 Tube Light	20	633	12660
	LED	9	632	5688
	LED	50	2	100
Boys Hostel 4	T5 Tube Light	20	633	12660
	LED Bulb	9	632	5688
	LED	50	2	100
Boys Hostel 5	T5 Tube Light	20	144	2880
	LED	9	36	324
CPS School Boys Hostel	T5 Tube Light	20	102	2040
	Old Tube Light	40	144	5760
Boys Hostel (Baitarani)	T5 Tube Light	20	34	680
	Round LED	18	4	72
	LED	9	32	288
Boys Hostel (Swarna Rekha)	T5 Tube Light	20	78	1560
	LED	50	1	50
Brahmani Girls Hostel	T5 Tube Light	20	58	1160
	LED	9	48	432



Investment Grade Energy Audit of CUTM, Paralakhemundi

MT Girls Hostel	T5 Tube Light	20	206	4120
Indravati Girls Hostel	T5 Tube Light	20	108	2160
	LED	50	3	150
	LED Bulb	9	48	432
Mechanical Dept.	T5 Tube Light	20	28	560
	Old Tube Light	40	5	200
	Round LED	18	4	72
	Bulb	100	2	200
Dynamic and Vibration & Thermal Engg Lab	T5 Tube Light	20	2	40
	Old Tube Light	40	21	840
Biofertiliser Lab	T5 Tube Light	20	2	40
	Old Tube Light	40	4	160
Studio Apartment	T5 Tube Light	20	40	800
	LED	9	13	117
MDC Hostel	T5 Tube Light	20	105	2100
	LED	9	28	252
Mini Tool Room & Training Centre	T5 Tube Light	20	16	320
	2ft 2 ft LED	36	8	288
	LED Bulb	9	3	27
Old Guest House	T5 Tube Light	20	7	140
	LED Bulb	9	10	90
Staff Qtrs	T5 Tube Light	20	180	3600
	LED Bulb	9	300	2700
	Round LED	18	45	810
CUTM School	T5 Tube Light	28	281	7868
	Flood Light	150	2	300
Auditorium	2ft 2 ft LED	36	50	1800
Mini Dairy Unit	T5 Tube Light	20	3	60
	Old Tube Light	40	3	120
Power House	T5 Tube Light	20	15	300
	Old Tube Light	40	2	80
	LED	50	5	250
	2ft 2 ft LED	36	1	36
Street Lights	Total street lights	45	220	9900
	Solar 18 W 12 V	18	153	2754
	Cricket Ground	350	12	4200
	Indoor Ground	250	4	1000
	Tennis Court	350	6	2100
	Basket ball	250	4	1000
	Net Practice Ground	250	4	1000
	Volleyball	250	4	1000



Investment Grade Energy Audit of CUTM, Paralakhemundi

	Badminton Court	100	14	1400
	Flood Lights	150	6	900
	Sodium Vapour Lights	400	4	1600
	LED Pathway Lights (6 W per mtr)	6	300	1800
GYM	2ft 2 ft LED	36	3	108
	Old Tube Light	40	6	240
Total			6871	143727

4.2 O & M Practice, Energy Accounting and Monitoring For Lighting System

CUTM electrical maintenance team looks after the operation & maintenance of electric supply, ventilation & air conditioning, lighting system etc. The works involves maintenance of Lighting system, Light replacement, Switching on/off of street light. Solar Street light system installed and maintained by CUTM engineers. But now days the Timers are available and the electricians are switching on/off the street lighting by manually. It is recommended to install Timer in the Street Light Circuit.

It is observed that there is no proper document available for keeping the records of lighting maintenance, lux survey, lighting inventory list, area wise lighting consumption etc. A set of well designed format for lighting system record keeping may be developed and maintained at the earliest.

Proper lighting inventory list to be maintained, further during any replacement of lighting system, same may be simultaneously updated in the inventory.

The Monitoring and Targeting programs have been so effective that they show typical reductions in annual energy costs between 5% and 20%.

The essential elements of M&T system are

- Recording: Measuring and recording energy consumption.
- Analyzing: Correlating energy consumption to actual energy consumption
- Comparing:-Comparing energy consumption to an appropriate standard or benchmark.
- Setting Targets: Setting targets to reduce or control energy consumption.
- Monitoring: Comparing energy consumption to the set target on a regular basis.
- Reporting: Reporting the results including any variances from the targets which have been set.
- Controlling:-Implementing management measures to correct any variances, which may have occurred.



4.3 Illumination Survey and Lux Level Measurement

The Illumination survey and Electrical Equipment Inventory List of the CUTM Building including Corridor were carried out by measuring the Lux of the different area, Lab, Office Room, Auditorium, Street Light and Class Room using Lux meter, by physical counting of inventory and the results are tabulated below.

Table 28: Lux Measurement

Lux Measurement		
Area	Measured Lux	Recommended Lux
Lab	65,89,55,73,88	200-300-500
Office Room	82,85,71,76,180	50-100-150
Auditorium	85,115,135,185	200-300-500
Street Lights	15,44,11,109	50-100-150
Class Room	70,91,77,83,86,79	200-300-500

4.4 Energy Conservation Option

It was observed that LUX level of street lights at different location are between 5 to 8 which is not satisfactory. Since there is less occupancy & less movement in the street light area during night time, so the low LUX level is not causing any difficulties

The periodic checking of load unbalances should be carried out so as to limit the unbalance less than 10%.

It is suggested to conduct periodic Lux level survey (preferably once in 3 months) and maintain record properly. Necessary corrective actions should be taken periodically.

Awareness among staff, student and control room operators is to be created for improvement in all aspects of energy conservation especially relating to lighting in their respective wings.

4.5 Electrical Load Distribution

In CUTM, Paralakhemundi apart from lighting load there are different types of electrical load likes fans, Computers, Printers, TVs, Geyser, Fridge and other home appliance etc. The summary of connected electrical load is furnished below.

**Table 29: Details of Total Connected Electrical Load**

Summary of Electrical Load	
Load Centre	Kilo Watt
Lighting	143.727
Fan	409.271
AC	784.625
Other Load	401.068
Total	1738.691

4.6 UPS & Ventilation

At the time of audit period it is observed that there is no measure power consuming UPS system in CUTM.

Energy saving Opportunity:

It is recommended to keep the monitors of the computers in standby mode rather in screen saver mode to reduce the power consumption of the computers when not in use. It is difficult to quantify the saving on account of this measure. The investment will be zero and simple payback period will be immediate.

4.7 ENCON Option for Installation of Solar Water Heater

During Audit period it is observed that on daily basis approx 50 Liter of hot water is required for cooking purpose. It is recommended that after installation of Solar Water Heater, the annual LPG saving @300days will be 63 Kg, annual cost saving will be Rs. 0.1 Lakh. Around Rs. 0.13 Lakh of investment will be required and payback period shall be 2.13 years.

Table 30: Cost Benefit Analysis of Installation of Solar Water Heater

Cost Benefit Analysis of Installation of Solar Water Heater at CUTM Canteen		
Particulars	Unit	Value
Total Hot Water required in Canteen per Day	Ltr	50
Consumption of LPG for heating Water	Kg	0.21
Annual LPG Consumption for heating water	Kg	63
Annual expenditure due to LPG consumption for solar water heating @ 93.2/Kg	Rs.	5875
Installation Cost of 50 LPD Solar Water Heater	Rs.	12500
Annual financial saving due to reduction in LPG consumption	Rs. Lakh	0.1
Investment required	Rs. Lakh	0.13



Simple Payback Period	Year	2.13
-----------------------	------	------

4.8 ENCON Option for Installation of Solar Power Plant in Net Metering Concept

Concept of Net Metering:

Net metering is the concept which records net energy between export of generated energy and import of DISCOM energy for a billing month. Alternatively, the meter, having the feature of recording both the import and export values, also are generally allowed for arriving net energy for the billing period.

Principle of net metering:

Based on available roof area / ground area solar PV panels will be installed. The output of the panels (DC electricity) will be connected to the power conditioning unit / inverter which converts DC to AC. The inverter output will be connected to the control panel or distribution board of the building to utilise the power. The inverter synchronizes with grid and also with any backup power source to produce smooth power to power the loads with preference of consuming solar power first. If the solar power is more than the load requirement, the excess power is automatically fed to the grid. For larger capacity systems connection through step up transformer and switch yard will be used to feed the power to grid.

Advantages of net metering:

The grid connected roof top / ground mounted solar PV system would fulfill the partial / full power needs of large scale buildings. The following are some of the benefits of roof top SPV systems:

- Generation of environmentally clean energy
- Consumer becomes generator for his own electricity requirements
- Reduction in electricity consumption from the grid
- Reduction in diesel consumption wherever DG backup is provided
- Feeding excess power to the grid

It is recommended that after installation of Roof Top at CUTM, Paralakhemundi, the annual energy generation will be 588066 kWh, annual cost saving will be Rs. 35.3 Lakh. Around Rs. 177 Lakh of investments will be required and payback period shall be 5 years.

Table 31: Cost Benefit Analysis of Establishment of Solar Power Project in CUTM, Paralakhemundi

Establishment of Solar Power Project in CUTM Paralakhemundi		
Units Generation	Unit	Value
Total Annual Energy Consumed from TPCODL in FY 2020-21	kWh	588066
Average Base Demand from TPCODL	kW	67



Proposed capacity of the Solar Power Project to be installed inside CUTM	MW	0.353
Total Area Required	Acre	1.24
Total Project Cost Required	Rs. Lakh	177
Capacity Utilization Factor	%	19%
Net Annual Generation	kWh	588066
Annual Energy Saving	TOE	51
Weighted Average Rate of Electricity	Rs./kWh	6
Annual Saving in Energy Bills due to Consumption from own solar power	Rs. Lakh	35.3
Simple Payback Period	Years	5

Implementation:

1. The total project cost to be borne by the consumer, however consumer is eligible for any subsidy / grant from State Govt. / Central Govt. / MNRE as applicable from time to time Implementation of net metering facility shall be made applicable for the consumers having 3-phase supply service connection.
2. Protection system including its switch gear to be certified by concerned Ex. Engineer and harmonic suppressive device to be installed by such SPV generator to suppress the harmonics injection as harmonics is more in case of solar plants where conversion of DC to AC is taking place. Islanding protection requirements to be provided.
3. The SPV generator shall provide the indication of solar PV plant at the injection point for easy identification to the operating personnel.
4. The SPV generator needs to get statutory approvals from appropriate authority like Electrical Inspector for the connected equipment including its solar panels.
5. The proposed generator shall submit the prescribed application to the concerned Executive Engineer of local DISCOM who should be nodal authority for approval of the same.
5. The net meter / meter to be used for arriving net energy shall have the specifications prescribed.
6. Concerned JE of DISCOM shall issue a technical feasibility certificate and witness the synchronization of SPV plant with distribution network.
7. 0.5 class accuracy, tri-vector based energy meter, non ABT having the MRI downloading facility along with related accessories shall have to be installed by the SPV generator as per the specifications of DISCOM.
8. Spot billing is to be arranged by concerned DISCOM as per the billing period. DISCOM shall arrange to develop suitable software and incorporate in the billing instrument for such billing.

It is recommended to install 67 kW Solar Project in CUTM, Paralakhemundi.



5.0 HVAC System

At present, the air conditioning system in the CUTM is met through window /split AC of following number.

There is around 246 numbers air conditioning system in CUTM, Paralakhemundi

It is estimated that there is about 784.6 kW of AC load in CUTM contributing to about 45% of the total connected load.

Installed Air conditioning System of CUTM are furnished below:

Table 32: Detail Inventory of ACs of CUTM, Paralakhemundi

AC Inventory				
Area Name	Types of Load	Wattage of each load in kW	Nos. installed	Total connected Wattage in kW
CRC 1	Window AC	1.87	15	28.05
CRC 2	Window AC	1.87	29	54.23
Eicher Lab	Window AC	1.87	1	1.87
ITI Building	Window AC	1.5	1	1.5
	Split AC 1	2	2	4
	Split AC 2	1.5	5	7.5
MBA Block	Window AC	1.5	18	27
	Window AC	2.1	17	35.7
Library	Window AC	1.5	7	10.5
	Window AC	2.08	1	2.08
Student Activity Center	Window AC	2.08	1	2.08
	Split AC 1.5 T	1.5	7	10.5
CPS School Boys Hostel	Split AC	1.5	4	6
	Window AC	1.87	4	7.48
Mechanical Dept.	Split AC	1.5	2	3
	Split AC	1.5	1	1.5
Bio fertiliser Lab	Split AC	1.5	4	6
Studio Apartment	Window AC	1.87	45	84.15
MDC Hostel	Window AC	1.87	4	7.48
	Split AC	1.5	2	3
Mini Tool Room & Training Centre	Window AC	1.87	2	3.74
	Split AC	1.5	2	3
Old Guest House	Window AC	1.87	2	3.74
	Split AC	1.5	2	3
Staff Qtrs	Split AC	1.5	60	90
CUTM School	AC	1.5	4	6
Auditorium	Centralised AC 3 units 35 Ton	123.095	3	369.285
Power House	Window AC	1.87	2	3.74



	Split AC	1.5	1	1.5
GYM	Window AC	1.87	2	3.74
Total			246	784.625

5.1 Energy Conservation Option

Replacement of Old 1.5 AC with EESL 1.5 ton 5 Star Energy Efficient AC

Recommendation:

It is recommended that the existing 1.5 Ton AC to be replaced with EESL 1.5 Ton 5 Star rated AC. After replacement of old AC, the annual energy saving will be 382878 kWh, annual cost saving will be Rs. 23 Lakh. Around Rs. 98.7 Lakh of investment will be required and payback period shall be 4.3 years.

Table 33: Cost Benefit Analysis of AC

Cost Benefit Analysis for Replacement of Old 1.5 Ton AC with EESL 1.5 ton 5 Star Super Energy Efficient AC		
Particular	Unit	Value
Present nos. of 1.5 Ton AC	Nos.	239
Total Capacity	TR	358.5
Av. Electrical Load of each existing AC before Replacement	kW	1.755
Total Av. Electrical Load before Replacement	kW	419.445
Annual Energy consumption without Energy Efficient AC @300*12hr	kWh	1510002
Present Load before Replacement	kW	419.445
Av. Electrical Load of new AC after Replacement	kW	1.31
Total Av. Electrical Load after Replacement	kW	313
Annual Energy consumption with EESL AC @300*12hr	kWh	1127124
Annual Energy Saving due to Installation of EESL Super Efficient AC	kWh	382878
Annual Cost of Savings @ Rs.6.0/unit	Rs. Lakh	23
Investment required	Rs. Lakh	98.7
Simple payback period	Years	4.3

Table 34: EESL-SEAC BOQ (Voltas)

EESL-SEAC BOQ (Voltas)		
Sl.N o.	Descriptions of Item	
1	Supply of 1.5 TR split inverter AC, Rated ISEER 5.4. energy efficient 5 Star AC. (indoor unit, outdoor unit, remote control)	1 No.s
a	Refrigeration Piping(Copper) for 1.5 TR Hi wall	3



Investment Grade Energy Audit of CUTM, Paralakhemundi

	Unit- (RMT)	
b	Electrical Cable - (RMT)	3
c	Drain Pipe - (RMT)	3
2	No of Preventive Maintenance Service in a Year	2



Star Rating	Stars	5
Cooling Capacity Full Load (100%)	W	5280
Cooling Capacity Half Load (50%)	W	2640
Cooling Power Full Load (100%)	W	1310
Cooling Power Half Load (50%)	W	433
ISEER		5.4
Power Supply	V/Hz/Ph	230 / 50 / 1 Phase
Air Flow Volume - Indoor	CMH	950
*Noise Level - Indoor	..dB(A)	≤46
Operation		LCD Remote
Compressor Type		High EER Twin Rotary - BLDC
Wide Operating Voltage Range	V	145~270
Max operating Ambient Temp Range	Deg C	52° C
Refrigerant Gas		R32
Indoor Unit Dimension (WxHxD)	mm	990x315x242
Indoor Unit Net / Gross Weight	Kg	13.5/16.5
Outdoor Unit Dimension (WxHxD)	mm	870x600x355
Outdoor Unit Net / Gross Weight	Kg	33.5/39
Connecting Pipe	type	Cu-Cu(12.5mm & 6.35mm)
Connecting Pipe Length	Meter	3.0
Connecting Cable	Meter	3.0
Condenser		Fin & Tube



Coil			
No of boxes		ODU	1 Box
		Connecting Tube	
		IDU	1 Box
Features	Filter	Anti Dust	Yes
		Catechin Filter	Yes
		Acaro Bacterium	Yes
		Silver Ion	Yes
	IDU Fin	Hydrophylic Aluminum	Blue
	Copper tubes	Inner Grooved	Yes
	IDU	LED Display	Yes
		Self Diagnosis	Yes
		Anti Fungal	Yes
		5D Concept	Yes
		Auto Restart	Yes
	Remote	Sleep Mode	Yes
		Turbo	Yes
		Swing	Yes
		LCD Remote	Yes
		Lock	Yes
		Timer	Yes
		Glow Buttons	Yes
	Air Vent	Dual Temp Display	Yes
		Cross Flow	Yes

* Noise level reflects the levels in Anechoic Chamber
 All above performance data are as per IS 1391 Rated conditions

No Derating in cooling capacity at 43 degree Celsius

Cost per AC (For Consumer) in INR - (1 Year Comprehensive Warranty & 5 Year Warranty on Compressor)				39990
Miscellaneous Cost				Voltas
1	Additional warranty for one year i.e. for 2nd year post the expiry of the standard one year warranty ; inclusive of GST	Unit		2200
2	Additional warranty for one year i.e. for 3rd year post the expiry of the standard one year warranty ;inclusive of GST	Unit		2400
3	Copper Pipe ; inclusive of GST	Per Meter		600
4	EPPDM Rubber Insulation for refrigerant piping ; inclusive of GST	Per Meter		90



5	Power Cable ; inclusive of GST	Per Meter		120
6	Drain Pipe ; inclusive of GST	Meter		100
7	Buyback of old Acs ; inclusive of GST	Unit		2500
8	Additional warranty for 4 year (Inclusive of GST)			4000

5.2 Advantages of Inverter Air Conditioner

The latest and the most efficient technology that is available in market today is the Inverter Technology for air conditioners. Inverter technology is designed in such a way that it can save 30-50% of electricity (units consumed) over a regular air conditioner.

Inverter air conditioners are more powerful, offer great savings and are better at maintaining temperature compared to non-inverter air conditioners. When compressor needs more power, it gives it more power. When it needs less power, it gives less power. With this technology, the compressor is always on, but draws less power or more power depending on the temperature of the incoming air and the level set in the thermostat. The speed and power of the compressor is adjusted appropriately.

Let's take an example of 1.5 Ton inverter air conditioner versus non-inverter air conditioner

A 1.5 Ton inverter air conditioner works initially at 1.7 Ton and as the desired temperature is achieved it reduces its capacity to 1.5, 1 or .3 Ton based on room conditions.

A 1.5 Ton non-inverter air conditioner on the other hand works at 1.5 Ton all the times.

Every air conditioner is designed for a maximum peak load. So a 1.5ton AC is designed for a certain size of room and 1 ton for a different size. But not all rooms are of same size. A regular air conditioner of 1.5ton capacity will always run at peak power requirement when the compressor is running. An air conditioner with inverter technology will run continuously but will draw only that much power that is required to keep the temperature stable at the level desired. So it automatically adjusts its capacity based on the requirement of the room it is cooling. Thus drawing much less power and consuming lesser units of electricity.

5.3 Maintenance Tips for Split / Window AC

- Make sure AC doesn't get overloaded; check the fuse or circuit breaker if it doesn't operate.
- Remember to replace or clean the filter and have your mechanic clean the evaporator and condenser coils regularly, for the air conditioner to cool the home efficiently.
- Install a programmable thermostat, it will lead to 10-15% energy saving.
- Set the thermostat as high as possible comfortable.
- Set the fan speed on high except on very humid days, when humidity is high set the fan speed on low for more comfort.
- Install units in shade, it will lead to 10% saving in energy consumption.
- Use sun films on windows. That will cut heat entry by 70% of the building.



- If the AC makes noise it needs to be checked by the mechanic
- A good air filter will extend the life of the air conditioner because the important parts, like the cooling coil, and other inner parts will stay cleaner, operate more efficiently and last longer.
- Avoid frequent opening of doors/windows. A door kept open can result in doubling the power consumption of your AC.
- Ensure direct sunlight (and heat) do not enter the air-conditioned space, particularly in the afternoons.
- Most people believe that a thermostat set to a lower temperature than desired, will force air-conditioner to cool faster, not really, all it does, is make air-conditioner operate for longer. Moreover, it will result in unnecessarily chilly room and wasted power. Every degree lower on the temperature setting results in an extra 3-4% of power consumed. Hence, once a comfortable temperature found then set the thermostat at that level, avoid touching the thermostat thereafter.
- Once an air-conditioning system has been designed and installed avoid any major change in the heat-load on the AC. This will add to wasted power.
- Always ensure that whenever new unit is installed, make sure its EER (12/ (kW/TR)) should be between 9.5 to10.5.
- No gap should be left during installing units for cool air escape.

6.0 Fan Inventory

Table 35: Fan Inventory

Fan Inventory				
Area Name	Types of Load	Wattage of each load in kW	Nos. installed	Total connected Wattage in kW
CRC 1	Ceiling Fan	0.1	200	20
CRC 2	Ceiling Fan	0.1	126	12.6
Eicher Lab	Ceiling Fan	0.1	8	0.8
	Wall Fan	0.035	7	0.245
Mechanical Workshop Lab	Ceiling Fan	0.1	41	4.1
	Wall Fan	0.035	6	0.21
Central Mess 1	Ceiling Fan	0.1	44	4.4
	Exhaust Fan	0.075	3	0.225
Central Mess 2	Ceiling Fan	0.1	28	2.8
	Wall Fan	0.05	3	0.15
ITI Building	Ceiling Fan 1	0.1	7	0.7
	Ceiling Fan 2	0.07	43	3.01
	Ceiling Fan 3	0.05	1	0.05
	Wall Fan	0.05	22	1.1
MBA Block	Ceiling Fan	0.1	201	20.1
	Wall Fan	0.05	5	0.25



Investment Grade Energy Audit of CUTM, Paralakhemundi

	Table Fan	0.075	9	0.675
Store Office	Ceiling Fan	0.1	4	0.4
	Wall Fan	0.05	1	0.05
	Exhaust Fan	0.075	1	0.075
Hostel for Tribal students SAIL	Ceiling Fan	0.1	110	11
Library	Ceiling Fan	0.1	62	6.2
	Wall Fan	0.035	1	0.035
	Stand Fan	0.15	1	0.15
Student Activity Center	Ceiling Fan	0.1	35	3.5
	Wall Fan	0.035	3	0.105
	Exhaust Fan	0.075	6	0.45
Boys Hostel 1	Ceiling Fan	0.1	243	24.3
Boys Hostel 2	Ceiling Fan	0.1	632	63.2
	Wall Fan	0.035	1	0.035
Boys Hostel 4	Ceiling Fan	0.1	632	63.2
	Wall Fan	0.035	1	0.035
Boys Hostel 5	Ceiling Fan	0.1	207	20.7
CPS School Boys Hostel	Ceiling Fan	0.1	207	20.7
Boys Hostel (Baitarani)	Ceiling Fan	0.1	33	3.3
	Exhaust Fan	0.075	32	2.4
Boys Hostel (Swarna Rekha)	Ceiling Fan	0.1	27	2.7
	Exhaust Fan	0.075	5	0.375
	Wall Fan	0.035	27	0.945
Brahmani Girls Hostel	Ceiling Fan	0.1	51	5.1
	Exhaust Fan	0.075	48	3.6
MT Girls Hostel	Ceiling Fan	0.1	203	20.3
Indravati Girls Hostel	Ceiling Fan	0.1	96	9.6
	Exhaust Fan	0.075	48	3.6
	Wall Fan	0.035	1	0.035
Mechanical Dept.	Ceiling Fan	0.1	17	1.7
	Wall Fan	0.035	2	0.07
Dynamic and Vibration & Thermal Engg Lab	Ceiling Fan	0.1	23	2.3
Biofertiliser Lab	Ceiling Fan	0.1	2	0.2
	Exhaust Fan	0.075	1	0.075
Studio Apartment	Ceiling Fan	0.1	40	4
MDC Hostel	Ceiling Fan	0.1	104	10.4



Investment Grade Energy Audit of CUTM, Paralakhemundi

	Exhaust Fan	0.075	16	1.2
Mini Tool Room & Training Centre	Ceiling Fan	0.1	10	1
Old Guest House	Ceiling Fan	0.1	8	0.8
Staff Qtrs	Ceiling Fan	0.1	180	18
CUTM School	Ceiling Fan	0.1	290	29
	Exhaust Fan	0.075	1	0.075
Mini Dairy Unit	Wall Fan	0.035	4	0.14
	Big Wall Fan	0.746	1	0.746
	Exhaust Fan	0.075	3	0.225
Power House	Ceiling Fan	0.1	6	0.6
	Wall Fan	0.035	1	0.035
GYM	Ceiling Fan	0.1	12	1.2
Total			4193	409.271

6.1 Energy Conservation Option

It is observed that there is a scope in energy conservation in fan system by replacing Conventional Ceiling Fan with 28W Energy Super Efficient Fan. By using recommended fan the annual energy saving will be 668736 kWh and financial saving will be around Rs. 40.1 Lakh & investment required will be Rs. 77.4 Lakh with simple payback period of 1.9 Years.

Table 36: Cost Benefit Analysis of Fan

Cost Benefit Analysis for Replacing Conventional Ceiling Fan with 28W Super Energy Efficient Fan		
Total No. of Fans Operating	Nos.	3870
Present Load before Replacement @ 100W per Fan	kW	387
Load after Replacement @ 28 W per Fan	kW	108
Saving in Load	kW	279
Run hour /Day	hr	8
Annual Energy Saving Assuming 300 Days	kWh	668736
Annual Energy Saving	TOE	58
Total Investment	Rs. Lakh	77.4
Annual Cost of Savings @ Rs 6/unit	Rs. Lakh	40.1
Simple Payback Period	Years	1.9



7.0 DIESEL GENERATING (DG) SET

7.1 Observation & Analysis for DG Set

- There are one no. of DG sets of 380 KVA capacity installed in CUTM to meet the power requirement of the major areas of the building in case of power supply failure from TPSODL.
- The technical specification of the DG Set is furnished below:

Table 37: Technical specification of the DG set

Technical Specification of DG	
Particulars	DG Set 1
Make	Jackson
Capacity in kVA	380
Phase	3
Rated Voltage in Volt	415
Rated Current in Amp	529
Rated PF	0.85
Rated Speed in RPM	1500
Date of Mfg	19-08-2011
Rated Fuel Consumed in Litre/Hour	3

Diesel Consumption of 380 kVA DG Set for 3 Year is furnished bellow:

Table 38: Diesel Consumption of 380 kVA DG Set for FY 2018-19

Energy Data Sheet of 380 kVA DG Set for FY 2018-19	
Month	Diesel Consumption in kL
Apr-18	1.600
May-18	2.200
Jun-18	2.400
Jul-18	1.400
Aug-18	1.400
Sep-18	3.750
Oct-18	6.900
Nov-18	3.900



Dec-18	3.000
Jan-19	1.200
Feb-19	5.900
Mar-19	2.100
Total	35.750

Table 39: Diesel Consumption of 380 kVA DG Set for FY 2019-20

Energy Data Sheet of 380 kVA DG Set for FY 2019-20	
Month	Diesel Consumption in KL
Apr-19	5.300
May-19	3.592
Jun-19	2.600
Jul-19	3.800
Aug-19	3.000
Sep-19	4.000
Oct-19	2.000
Nov-19	2.400
Dec-19	1.800
Jan-20	0.000
Feb-20	0.630
Mar-20	1.100
Total	30.222

Table 40: Diesel Consumption of 380 kVA DG Set for FY 2020-21

Energy Data Sheet of 380 kVA DG Set for FY 2020-21	
Month	Diesel Consumption in KL
Apr-20	0.600
May-20	0.600
Jun-20	0.800
Jul-20	0.000
Aug-20	0.400
Sep-20	0.600
Oct-20	0.200
Nov-20	0.000



Dec-20	0.800
Jan-21	0.000
Feb-21	0.400
Mar-21	0.400
Total	4.800

7.2 Recommendation

- The DG sets are normally operated in power failure condition and in any emergency load requirement case.
- The details of energy generated and consumption of Diesel for both the DG set is not being recorded presently for which the specific energy consumption of DG set could not be evaluated.
- So it is recommended that the DG set generation and HSD consumption details are be noted monthly basis in log book for future reference and evaluation of SEC.
- Both the DG set should be inspected by Electrical Inspector; Energy Meter should be installed across the DG set and sealed properly in consultation with Chief Electrical Inspector.
- The record of energy generated in DG set is not available. It is to be recommended that energy meter is to be installed in each DG set and the energy generated in each DG set has to be recorded to calculate the specific energy consumption of DG set.

8.0 TRANSPORTATION

It is observed that the University has 10 numbers of buses, 9 numbers of four wheeler for transportation & 2 tractors for agriculture purpose. The list of the vehicles is mentioned bellow.

Table 41: Vehicle Detail of CUTM, Paralakhemundi

Vehicle Details of CUTM, Paralakhemundi		
Vehicle No.	Vehicle Type	What is this Used for
OD02BC-5758	Light	Office & Guest
OD33U-6638	Light	Office & Guest
AP31DT-1162	Light	Office & Guest
OD33U-7252	Light	Office & Guest
AP30AA-4335	Light	Office & Guest
OD02T-0727	Light	Office & Guest
OD-20-B-7281	Light	Office & Guest



AP30W-9741	Light	Office & Guest
OR02AL-7348	Light	Ambulance
AP31TA-5168	BUS	College
AP30TA-2956	BUS	College
AP39TC-3308	BUS	College
AP39TC-3309	BUS	College
OD20A-1494	BUS	College & AGBS
OD02A-1496	BUS	College & School
OD02A-1619	BUS	College & School
OD02A-1823	BUS	College & School
OD02-4624	BUS	College & School
OD02-4813	BUS	College & R.N.R
OD02-3675/A- 2475	Tractor	Agriculture
OD20-7799/7800	Tractor	Agriculture

Recommendation:

It is recommended that either replace the lower efficiency vehicles with EESL Electric Vehicles or they may be operated for smaller distances.

Details of EESL Electric Car

- Cheaper to run:** EV have the advantage of much lower running cost & the electricity to charge an EV costs around one-third of the cost of buying petrol for driving the same vehicle for one kilometer.
- Cheaper to maintain:** A battery vehicle (BEV) has lesser moving parts than a conventional petro diesel car. It requires lesser servicing and does not have expensive exhaust systems, starter motors, fuel injection system, radiators.
- Less pollution:** EVs will help in reducing harmful air pollution from exhaust emissions. An EV has zero tailpipe emissions.
- Renewable energy:** If we use renewable energy to recharge EV, we can reduce greenhouse gas emissions even further. We can recharge EV from solar PV system during the day instead of the grid electricity. We can also purchase 'Green Power' from electricity retailer.
- Health benefits:** Reduced harmful exhaust emissions, and better air quality will improve public health. EVs are also quieter than petrol/diesel vehicles which mean less noise pollution.
- Traffic:** A shift to EV-based public transport systems can be immensely helpful in reducing the traffic congestion on roads.

Impact:



- **Fuel Savings:** Over **1.65 crores** liter of fuel will be saved every year (with 10,000 e-cars)
- **Emissions:** Reduced tailpipe CO₂ emission of **4.46 tCO₂**, saving of **1,664 liters** of diesel annually.

8.1 Energy Conservation Option

Table 42: Cost Benefit Analysis of E-rickshaw by replacing conventional vehicle

Cost Benefit Analysis of E-rickshaw by replacing conventional vehicle		
Particulars	Unit	Value
Total number of E-rickshaw	Nos.	1
Daily distance travelled by one rickshaw	km	80
Daily distance travelled by all rickshaw	km	80
Monthly distance travelled	km	2400
Monthly fuel consumption (@ avg. mileage 35 km)	litre	69
Annual fuel consumption	litre	823
Annual fuel saving	litre	823
Annual energy saving	TOE	0.001
Monthly saving @Rs. 91/litre	Rs.	6240
Annual saving	Rs. Lakh	0.69
Investment Required	Rs. in Lakh	1.6
Simple Payback Period	Years	2.3



Figure 25: Electric Mobility Programme



9.0 WATER PUMPING SYSTEMS

9.1 Water Pumping Storage and Distribution System

CUTM meets its water requirement from Ground water through sump storage facility, the pump motors is having various connections like both single and 3-phase connection.

9.2 Utilization of water Pumping System

There are submersible types of pumps installed in CUTM for the auxiliary consumption of water like housekeeping, gardening etc. There are 7 nos. of 3 HP submersible pumps, 2nos. of 2 HP pumps, 3nos. of 5 HP pumps and one number of 7.5 & 1.5 HP pump.

9.3 Mechanical Power Transmission Study and Rational Usages of Drives

There are submersible types of pumps installed in CUTM for the auxiliary consumption of water like housekeeping, gardening etc. Though these are submersible type pump, hence the study mechanical power system could not be carried out and hence no recommendation is furnished for the same. It is recommended that in future flow meter to be installed and water consumption to be monitored.



9.4 Rain Water Harvesting System

The rainwater harvesting system is one of the best methods practiced and followed to support the conservation of water. Today, scarcity of good quality water has become a significant cause of concern. It is recommended that RWH system may be installed for water conservation.

9.5 Sewage Treatment Plant

The campus has four sewage treatment plants for the primary Treatment and management of sewage generated in the campus including its hostel and residential area. The treated water is used for gardening purposes inside the campus. The use of treated water will reduce the ground water use and additionally the treated sludge will be very useful increasing the fertility of the soil. The photographs of the STP site are furnished below.

Figure 26: Sewage Treatment Plant



10.0 WIND PLANT & BIOGAS PLANT

10.1 ENCON Option for Installation of 3 kW Wind Plant

It is recommended to installed 3 kW Wind Plant in CUTM Paralakhemundi campus on pilot basis. By installing wind plant the annual generation will be 7884 kWh, annual cost saving will be Rs. 0.5 Lakh. Around Rs. 1.7 Lakh of investment will be required and payback period shall be 3.49 years.

**Table 43: Cost Benefit Analysis by Installation of 3 kW Wind Plant**

Cost Benefit Analysis by Installation of 3 kW Wind Plant		
Particulars	Unit	Value
Installed Power Generation Capacity	kW	3
Capacity Utilization Factor	%	30
Net Annual Generation	kWh	7884
Rate of Electricity	Rs./kWh	6
Annual Saving in Energy Bills due to Consumption from own wind plant	Rs. in Lakh	0.5
Investment Required	Rs. in Lakh	1.7
Simple Payback Period	Years	3.49

10.2 Financial Benefit by Installation of Biogas Plant

It is recommended to install Biogas Plant for 140 Kg waste. By installing Biogas Plant, annual LPG saving @300days will be 2100 kg, annual cost saving will be Rs. 1.96 Lakh. Around Rs. 4 Lakh of investment will be required and payback period shall be 2.04 years.

Table 44: Cost Benefit Analysis by Installation of Biogas Plant

Cost Benefit Analysis by Installation of Biogas Plant at CUTM Paralakhemundi		
Particulars	Unit	Value
Total waste generated in Canteen per Day	Kg	140
Treatment Capacity of Waste per day	kg	100
Amount of Equivalent LPG Gas can be generated for 100 kg of Waste	Kg	7
LPG Gas can be saved per day	Kg	7
Annual LPG Saving @300 Days	Kg	2100
Annual Cost Saving Rupees @ 93.2/Kg	Rs. Lakh	1.96
For Installation 15 M3 Biogas for 100kg waste	Rs. Lakh	4
Simple Payback Period	Year	2.04



11.0 FINANCIAL ANALYSIS OF PROPOSED ENERGY CONSERVATION PROJECT

Table 45: Financial Analysis of Proposed Project

Details of Energy Conservation measures / Recommendations of Accredited Energy Auditor for Improving Energy Efficiency						
[See rule 3(1) (c)]						
Energy Saving measures	Anticipated Investment (In Lakh)	Anticipated Annual Savings (In Lakh)	Simple Pay Back Period in Year	Anticipated Annual Energy Savings		
				Electricity in kWh	Thermal Energy in Gcal	Equivalent Energy in TOE
Reduction of Contract Demand in CUTM Paralakhemundi	Minor	6.00	Immediate			
Installation of Solar Water Heater at CUTM Canteen	0.13	0.06	2.128			
Installation of Biogas Plant at CUTM Canteen	4	2	2.0			
Installation of 3 kW Wind Plant	1.7	0.5	3.5			
Establishment of Solar Power Project in CUTM Paralakhemundi	177	35.28	5.01	588066		51
Replacement of Old 1.5 Ton AC with EESL 1.5 ton 5 Star Super Energy Efficient AC	98.7	22.97	4.30	382878		33
Replacing Conventional Ceiling Fan with 28W Super Energy Efficient Fan	77	40.1	2	668736		58
Total	359	107	3	1639680	0	141

11.1 Operation and Maintenance of CUTM

CUTM Electrical Maintenance team looks after the operation & maintenance of electric supply, ventilation & air conditioning, lighting system etc. of the entire building to ensure proper work environment and comfort of its residents and officials. There are 4 nos. of Electricians working in CUTM . The work involves maintenance of lift, AC, motor, normal Fuse call Attending, Light replacement, Switching on/off of street light.



11.2 Energy Monitoring & Accounting System

Energy monitoring and targeting (M & T) is primarily a management technique that uses energy information as a basis to eliminate waste, reduce and control current level of energy use and improve the existing operating procedures. It builds on the principle “you can’t manage what you don’t measure”. It essentially combines the principles of energy use and statistics.

While, monitoring is essentially aimed at establishing the existing pattern of energy consumption, targeting is the identification of energy consumption level which is desirable as a management goal to work towards energy conservation.

Monitoring and Targeting is a management technique in which building utilities such as fuel, refrigeration, water, effluent, and electricity are managed as controllable resources in the same way that inventory, building occupancy, personnel and capital are managed. It involves a systematic, disciplined division of the facility into Energy Cost Centers. The utilities used in each centre are closely monitored. Once this information is available on a regular basis, targets can be set, variances can be spotted and interpreted, and remedial actions can be taken and implemented.

The Monitoring and Targeting programs have been so effective that they show typical reductions in annual energy costs in various industrial sectors between 5 and 20%.

The essential elements of M&T system are:

- Recording: Measuring and recording energy consumption.
- Analyzing: Correlating energy consumption to actual energy consumption
- Comparing:-Comparing energy consumption to an appropriate standard or benchmark.
- Setting Targets: Setting targets to reduce or control energy consumption.
- Monitoring: Comparing energy consumption to the set target on a regular basis.
- Reporting: Reporting the results including any variances from the targets which have been set.
- Controlling:-Implementing management measures to correct any variances, which may have occurred.

The energy used by any business varies with production processes, volumes and input. Determining the relationship of energy use to key performance indicators will allow the Building owner to determine:

- Whether the current energy is better or worse than before
- Trends in energy consumption that reflects seasonal, weekly, and other operational parameters
- How the future energy use is likely to vary Specific areas of wasted energy
- Comparison with other business with similar characteristics - This “benchmarking” process will provide valuable indications



Electrical Safety:

It is observed that the Single Line Diagram (SLD) of the entire electrical system is to be displayed at concerned places. This will help in identifying the fault easily and doing the maintenance job more effectively. The SLD should be reviewed once in year to put necessary changes.

At Panel rooms, the following points are suggested as per safety & electricity rules.

- Rubber mats should be placed on the floor around the PDB panels in each switch room.
- No panel door should be kept open in both sides.
- Proper bunching of cables should be ensured at each switch room. The cables should be clearly tagged at starting & ending points which would help for easy the identification of cables for fault finding & maintenance work.
- Danger plates should be displayed at concerned places.
- Proper naming of loads should be done on each panel.

Awareness and attitude of occupants toward energy efficiency:

It is suggested to create energy conservation awareness among the staff by observing Energy Conservation Day, encouraging & recognizing energy conservation efforts made by any individual or groups. A core committee on Energy Conservation, Electrical Safety, and Resource conservation may also be formed to review the related activities.

12.0 TECHNICAL SPECIFICATIONS FOR ENERGY EFFICIENT PRODUCT

1. Capacitor Bank

Standard parameter	Valve/Feature
Total rating of capacitors	60 kVAr
Rated AC Voltage	440Volt
Frequency	50 HZ
No. of Phases	3 phase
Standard	IS 13340-1993
APFC relay	Microprocessor Based
Losses	< 0.2 W/kVAr

2. Lighting

Standard Parameter	Feature
Voltage	220 - 240 V
Shape	Bulb
Lifetime of lamp	15000 hour(s)
Lumen maintenance factor	0.7



Average life (at 2.7 hrs/day)	15.2 year(s)
Number of switch cycles	50000
Rated luminous flux	1400 lm
Rated lifetime	15000 hour(s)
Rated beam angle	150 degree
Light output	1400 lumen
Beam angle	150 degree
Colour temperature	6500 K
Light effect/finish	Cool Daylight
Colour rendering index (CRI)	80
Starting time	<0.5 s
Warm-up time to 60% light	Instant full light
Colour	Cool Daylight

3. Air Conditioner

Standard Parameter	Feature
Window AC (1.5 Ton)	
Cooling Capacity (Watt)	5265
Max Power Consumption (Watt)	1847
Preferable BEE Star Rating	3
Energy Efficiency Ratio (EER)	2.85 W/W
Preferable Compressor Type	Rotary/reciprocating
Preferable Refrigerant Gas	R-22
Window AC (2 Ton)	
Cooling Capacity (Watt)	7020
Max Power Consumption (Watt)	2463
Preferable BEE Star Rating	3
Energy Efficiency Ratio (EER)	2.85 W/W
Preferable Compressor Type	Rotary/reciprocating
Preferable Refrigerant Gas	R-22
Split AC (1.5 Ton)	
Cooling Capacity (Watt)	5265
Max Power Consumption (Watt)	1815
Preferable BEE Star Rating	4
Energy Efficiency Ratio (EER)	2.90 W/W
Preferable Compressor Type	Rotary/reciprocating
Preferable Refrigerant Gas	R-22
Split AC (2 Ton)	
Cooling Capacity (Watt)	7020



Max Power Consumption (Watt)	2420
Preferable BEE Star Rating	4
Energy Efficiency Ratio (EER)	2.90 W/W
Preferable Compressor Type	Rotary/reciprocating
Preferable Refrigerant Gas	R-22

4. 50 LPD Solar Water Heater

Standard Parameter	Feature
Specification	S.S 0.8mm THICKNESS INNER TANK 47mm X 1500mm ETC GLASS TUBES
System Capacity in LPD	50
Nos. of Tubes	8

5. Energy Efficient Fan

Model Name	E1-1200
Reversible Rotation	No
Remote	Yes
Blade Material	Aluminum
Leaf	3

Weight (kg)	4
Dimensions	120 x 140 cm
Down rod Height	30.48 cm
Span (mm/inch)	1200/48
Rated Voltage *	140 - 285
Rated Frequency	48 - 52
Input Power (typical)	28
Power Factor (typical)	0.95
Air Delivery	230



STAR RATING IN ROOM AIR CONDITIONERS

New BEE Energy Efficiency Ratings (EER) for Room Air Conditioners					
STAR RATING LEVELS - Jan 1, 2014 - Dec 31, 2015					
EER (W/W)					
WINDOW AC			SPLIT AC		
Star Rating	Minimum	Maximum	Star Rating	Minimum	Maximum
1 Star ★	2.50	2.69	1 Star ★	2.70	2.89
2 Star ★★	2.70	2.89	2 Star ★★	2.90	3.09
3 Star ★★★	2.90	3.09	3 Star ★★★	3.10	3.29
4 Star ★★★★	3.10	3.29	4 Star ★★★★	3.30	3.49
5 Star ★★★★★	3.30	-	5 Star ★★★★★	3.50	-

STAR RATING IN DISTRIBUTION TRANSFORMERS

Rating	1 Star		2 Star		3 Star		4 Star		5 Star	
	Max Losses at 50% (Watts)	Max Losses at 100% (Watts)	Max Losses at 50% (Watts)	Max Losses at 100% (Watts)	Max Losses at 50% (Watts)	Max Losses at 100% (Watts)	Max Losses at 50% (Watts)	Max Losses at 100% (Watts)	Max Losses at 50% (Watts)	Max Losses at 100% (Watts)
kVA										
16	200	555	165	520	150	480	135	440	120	400
25	290	785	235	740	210	695	190	635	175	595
63	490	1415	430	1335	380	1250	340	1140	300	1050
100	700	2020	610	1910	520	1800	475	1650	435	1500
160	1000	2800	880	2550	770	2200	670	1950	570	1700
200	1130	3300	1010	3000	890	2700	780	2300	670	2100

STAR RATING IN PUMP SETS

Star Rating	Overall Efficiency of the Pump Set*
1 Star	≥ 1.00 & < 1.05
2 Star	≥ 1.05 & < 1.10
3 Star	≥ 1.10 & < 1.15
4 Star	≥ 1.15 & < 1.20
5 Star	≥ 1.20



13.0 MOU Format with EESL

MEMORANDUM OF UNDERSTANDING

This Memorandum of Understanding ("MOU"), effective from _____ is to confirm discussions between Energy Efficiency Services Ltd (EESL), a company organized under the laws of India; with its corporate office at 5th & 6th Floor, Core-3, SCOPE Complex, 7-Lodhi Road, New Delhi-110003 and Centurion University of Technology & Management (CUTM) At/Po- Alluri Nagar, R Sitapur, Via- Uppalada, Paralakhemundi, Odisha 761211.

Article 1: Purpose and Scope

This MOU confirms the preliminary discussions between CUTM and EESL regarding their intention to enter into transactions or services pertaining to implementation of energy efficiency measures at premises of CUTM.

A. Diagnostic Studies & Pilot Projects

- 1) Energy audits for entire campus to identify avenues for energy saving in electrical and thermal utilities
- 2) Water audits to identify areas/means to reduce specific water consumption
- 3) Lubricant and diesel Conservation Studies
- 4) Pilot studies on Cross-Cutting technologies

B. Implementation of Energy Efficiency Projects through innovative financial models

- 1) Installation/distribution of LED Lights and Energy Efficient appliances (Fans and / or Air Conditioners) across the facilities of CUTM.
- 2) Installation of energy efficient motors (IE3 type) in place of conventional motors
- 3) Installation of Smart Meters
- 4) Installation of Solar PV Power Projects

C. Capacity Building & Training

- 1) Technical training to campus executives on various topics pertaining to Energy Management, Maintenance Management, Water Management and Safety Engineering
- 2) Organizing suitable study tours and Guest Lectures on suitable topics
- 3) Creating cadre of energy professionals i.e. certified energy managers and auditors
- 4) Facilitating in Certification and Recognition: National Energy Conservation Award, Green Building etc.

EESL in consultation with CUTM shall execute the implementation of Energy Efficiency projects on ESCO Model (Energy Servicing Company). Under this activity, CUTM would provide the inventory list of their facilities / buildings and EESL would submit the Business and Financial proposal based on deemed savings principle leading to signing of Contract Agreements (s).

The activities are advisory services which EESL will provide with consultancy charges after mutual agreement between the Parties. EESL will submit proposals or annual work plans depending upon the requirement from CUTM.



Article 2: Non-Binding MOU for Future Cooperation

This MOU describes the general conditions and arrangements for further discussions between the parties and is non-obligatory. The exact terms and conditions of this future cooperation will be negotiated in due course and delineated in one or more separate and definitive agreements in the future, should circumstances warrant. Neither party shall be liable to the other for any claim, loss, cost, liability or investment opportunities arising out of directly or indirectly related to the other Party's decision to terminate this MOU, the other Party's performance under this MOU, or any other decision with respect to proceeding or not proceeding with the definitive agreement(s) or the Project(s). Further, each party acknowledges and agrees that the decision to enter into definitive agreement is the sole and absolute discretion of the other party.

Article 3: General Terms and Conditions

A) Term: This MOU shall remain in full force and effect for a period of thirty-six (36) months from the effective date, unless it is: (i) superseded by any or all of the definitive documents contemplated in Article 2 (or such other definitive documents as the parties may agree to enter into for their mutual benefit), or (ii) earlier terminated for convenience by the parties in writing by giving 30 (thirty) calendar days' notice.

B) Modification; Waiver; Severability; Assignment: No waiver of any right or remedy on one occasion by either party shall be deemed a waiver of such right or remedy on any other occasion, if any provision of this MOU is held invalid under any applicable law, such holding shall not affect the validity of remaining provisions and same shall continue in full force and effect. Neither party may assign this MOU, in whole or in part, without the prior written consent of both the non-assigning party.

C) Headings: Headings used in this MOU are for reference purposes only and shall not be used to modify the meaning of the terms and conditions of this MOU.

D) Entire Agreement: This MOU represents the entire understanding and MOU between the parties with respect to the subject matter hereof, and supersedes all prior and contemporaneous communications, representations or agreements, oral or written, regarding the subject matter hereof.

E) Counterparts: This MOU may be executed in two or more counterparts, each of which shall be deemed an original but all of which shall constitute the same MOU. This MOU and any document or schedule required hereby may be executed by facsimile signature that shall be considered legally binding for all purposes.

F) Confidentiality: In recognition of the confidential nature of this MOU and information developed or received hereunder Receiving Party shall not disclose or convey without the prior written consent of Disclosing Party any such technical information received from Disclosing Party or developed under this Agreement to any other party for the duration of the project and for a minimum period of ten (10) years from the date of project completion, termination or short closure. Receiving Party shall establish adequate procedures to prevent such transmittal of such technical information by its current employees.

The undertakings in Articles F shall not apply to the following:

- i. Information which is necessarily disclosed to third parties to enable the performance of work to be carried out in connection with this MOU, provided that the third party



receiving the information enters into an agreement to keep the information confidential in accordance with this Article F;

- ii. Information which is ordered to be disclosed by a court of competent jurisdiction;
- iii. Information which is already in the public domain (except because of any breach of this undertaking);
- iv. Information which the party receiving the information can demonstrate from written records was already known to it at the time of receipt of such information from the party disclosing the information.

AGREED AND ACCEPTED:

Centurion University of Technology & Management, Paralakhemundi

Energy Efficiency Services Limited

Name:
Designation:
Address:

Name:
Designation:
Address:
5th & 6th Floor, Core-3
SCOPE Complex, 7-Lodhi Road
New Delhi-110003

WITNESS



14.0 ENERGY MANAGEMENT POLICY

Energy management policy provides the foundation for setting performance goals and integrating energy management into an organization's culture. It is a well-known fact that a formal written energy policy acts both as: A public expression of an organization's commitment to energy management and working document to guide energy management practices and provides continuity.

It is the organization's best interest that support for energy management is expressed in a formal written declaration of commitment accompanied by a set of stated objectives, an action plan for achieving them and clear specifications of responsibilities.

The format of energy policy statement is various, but it usually includes the goal or objective of the organization and the more concrete targets in the field of Energy Management (or Energy Conservation). It often shows the major measures and time tables. The statement shall match the organization's mission statement or overall management strategy plan.

The guiding principle of the proposed energy conservation policy should include

- To endeavor for reduction in Specific Consumption of Energy in all forms and in all areas of operations.
- To ensure availability of information and necessary resources for achieving objectives and targets.
- To comply with all applicable legal, regulatory and other requirements related to energy use, consumption and efficiency.
- To espouse Energy Efficient Technology encompassing procurement of Energy Efficient Products and services and design for Energy Performance Improvement.
- To carry out Energy Audits and Energy Reviews at planned intervals to improve Energy performance.

Actual drafting / reviewing of energy policy will depend upon an organization's corporate culture and management style. We feel that the policy will get wider acceptance if all the concerned parties have been given the opportunity to contribute to the proposed amendment. All departmental representatives should be invited to make submission when the policy is reviewed. After the policy is reviewed, it should be approved by the Board and it should be formally adopted. Further it is recommended to form an energy conservation cell in CUTM in which faculty members from the electrical department, utility managers, finance manager and senior management representative should be there. They should organize regular monthly meetings and awareness programs in the campus. They should also explore possibilities for implementation of energy efficiency and renewable energy projects.



Annexure:

1. Format of Energy Bill:

SUMMARY OF ENERGY BILL OF ----- FOR FINANCIAL YEAR -----																			
Month	Energy Consumed in kWh	Av. Load Factor	Av. Power Factor	MD in kW	MD in kVA	Energy Charge in Rs.	Demand Charge in Rs.	PF Penalty (+ve) / PF Incentive (-ve)	Rebate	CSC	TOD Incentive	Overdraw Penalty	Delay Payment Surcharge	Interest on Security	Meter Rent in Rs.	Electricity Duty	Current Monthly Bill in Rs.	Energy Charge in Rs./kWh	Unit cost in Rs. per kWh
Apr																			
May																			
Jun																			
Jul																			
Aug																			
Sep																			
Oct																			
Nov																			
Dec																			
Jan																			
Feb																			
Mar																			
Total / Av.																			
Monthly Average																			
Daily Average																			



2. Technical Specification of DG Set & Energy Data Sheet of DG:

Energy Data Sheet of -----kVA DG Set for FY -----			
Month	Diesel Consumption in kL	Total Energy Generated in DG Set in kWh	SEC in Liter/kWh
Apr			
May			
Jun			
Jul			
Aug			
Sep			
Oct			
Nov			
Dec			
Jan			
Feb			
Mar			
Total			

3. Technical data sheet of ----- Transformers & Transformer Performance Assessment:

Technical data sheet of ----- Transformers	
Particulars	TRF no.-----
Make	
Transformer rated in kVA	
Rated voltage ratio in kV	
Rated current ratio in Amp	
No. of phase	
Vector diagram	
Type of cooling	
Measured voltage at LT side in kV	
Measured current LT Side in Amp	
Measured Power Factor	

Transformer Performance Assessment	
Details	TRF no.-----
Transformer Rating in KVA	
Measured voltage at LT side in kV	
Measured current in LT Side Amp	
No Load Loss (kW)	



Investment Grade Energy Audit of CUTM, Paralakhemundi

Full Load Loss of Transformer (kW)	
Measured load (kVA)	
% Loading on the Transformer (Measured kVA/ Rated kVA)	
Actual Losses of Transformer (kW)	
Operating Power Factor	
Total Actual Power Delivered by Transformer in kW	
Transformer Efficiency, %	
Transformer performance	

4. Lux Measurement

Lux Measurement		
Area	Measured Lux	Recommended Lux

5. Energy Management Training Program Log Sheet

Energy Management Training Program of CUTM, Paralakhemundi															
Sl. No.	Energy Committee Members	Designation	Ph. No.	April	May	June	July	August	September	October	November	December	January	February	March

**15.0 Vender Details of Projects**

Vender details for CUTM						
Sl. No	Vendor Name	Service	Address	Phone Number	Email	Website
1	Star Enterprises	Solar Water Heater	205A, Snehalata Apartment, Vivekananda Marg, Bhubaneswar-751002	9040310328/7008527362	starenterprisesbbsr@gmail.com	
2	Lavancha Renewable Energy Pvt.	Solar Water Heater	Ltd. Regus CBD, Level 9, East Wing, Raheja Towers, MG Road, Bengaluru – 560001	99006 66885 / 7348907677	niranjan.patil@lavancha.in / info@lavancha.in	https://www.lavancha.in/
3	Sky shade Daylights Pvt Ltd	Light Pipe system	#401, Jyothi Flora, Plot no. 240, B-Block, Kavuri hills, Madhapur, Hyderabad-500081	91-40 4020 4022/33	marketing@skyshade.in	www.skyshade.in
4	Tanstate Global	Light Pipe system	Regulus, S No 1/10/2, B 801, Balewadi Near PMC School Pune 411045	7219700559	tanstateglobal@gmail.com / tsg@tanstateglobal.com	http://www.tanstateglobal.com
5	KRISHNA	Biogas Plant	Plot No: 4723,	09114160231,	krishnaenergy@gmail.com /	www.krishnaenergy.com



	ENGINEERS & CONSULTANTS		Laxmi Vihar, Lane-3, Sainik School, Bhubaneswar, Odisha, India-751005	09437256123	krishnaenergy2@gmail.com	
6	Energy Efficiency Services Limited	AC Replacement	Ground Floor, House No. 409/B, Sahid Nagar, Bhubaneswar, Dist. Khordha Odisha - 751007.	9861486746	info@power-tech.group	
7	Energy Efficiency Services Limited	28W Super Energy Efficient Ceiling Fan	Ground Floor, House No. 409/B, Sahid Nagar, Bhubaneswar, Dist. Khordha Odisha - 751007.	9861486746	info@power-tech.group	
8	Solar Sack (A unit of Nemhans Solution Pvt. Ltd)	Solar Rooftop Project	N4/234,IRC Village, Nayapalli,Bhubaneswar	9238412384/99	quotation@solarsack.in	
9	UNIFY SOLAR	Solar Rooftop Project	DELHI	9212560106, 9667966755	unifysolar@gmail.com	http://www.unifysolar.in

INVESTMENT GRADE ENERGY AUDIT REPORT
of Centurion University of Technology & Management
Rayagada, Odisha



Submitted to:

Centurion University of Technology & Management

Pitamahal, Rayagada, Odisha- 765002

Tel-9437095990

Mobile: 9437095990

E-mail: rajeshkumar.padhi@gmail.com

Website: www.cutm.ac.in



Power Tech



Submitted by:

M/s. Swain and Sons Power Tech Pvt. Ltd.

Corporate Office: K-8-82, Kalinga Nagar, Ghatikia

Bhubaneswar-751029, Odisha

Phone: 0674-2954256, Mob: 9438747172, 8093533005, 9937159760

Email: sspt12@gmail.com, info@pwrtech.com

Website: www.pwrtech.com



Contents

List of Tables	4
LIST OF ABBREVIATIONS	5
ACKNOWLEDGEMENT	6
AUDIT TEAM DETAILS	7
CERTIFICATE	8
EXECUTIVE SUMMARY	9
1.0 INTRODUCTION	12
1.1. About The Site	13
1.2. Scope of Works	13
1.3. Methodology	15
1.4. Instruments Used	16
2.0 BRIEF DESCRIPTION OF THE UNIVERSITY	16
2.1 Major Utility	17
3.0 ENERGY SCENARIO	18
3.1 Analysis of Energy Bill	19
3.2 Base Line Energy Consumption and Specific Energy Consumption	23
3.3 Electrical Distribution System and Water Distribution System	27
3.4 Transformer Details	29
3.5 Study of Voltage, Current, Power Factor Profile	32
4.0 LIGHTING SYSTEM	37
4.1 Lighting Inventory	37
4.2 O & M Practice, Energy Accounting and Monitoring For Lighting System	42
4.3 Illumination Survey and LUX Level Measurement	43
4.4 Energy Conservation Option	43
4.5 Electrical Load Distribution	44
4.6 UPS & Ventilation	44
5.0 HVAC System	46
5.1 Energy Conservation Option	47
5.2 Advantages of Inverter Air Conditioner	50
5.3 Maintenance Tips for Split / Window AC	51
6.0 Fan Inventory	52
6.1 Energy Conservation Option	52
7.0 DIESEL GENERATING (DG) SET	53
7.1 Observation & Analysis for DG Set	53
7.2 Recommendation	54
8.0 TRANSPORTATION	54



9.0	WATER PUMPING SYSTEMS	55
9.1	Water Pumping Storage and Distribution System	55
9.2	Utilization of water Pumping System	55
9.3	Mechanical Power Transmission Study and Rational Usages of Drives	55
9.4	Rain Water Harvesting System	56
9.5	Sewage Treatment Plant	56
9.6	Financial Benefit by Installation of Solar Water Heater	56
9.7	Operation and Maintenance of CUTM	56
9.8	Energy Monitoring & Accounting System	57
10.0	TECHNICAL SPECIFICATIONS FOR ENERGY EFFICIENT PRODUCT	58
11.0	MOU Format with EESL	63
12.0	ENERGY MANAGEMENT POLICY	66
Annexure:		67
13.0	Vender Details of Projects	71



List of Tables

TABLE 1: SUMMARY OF ENERGY BILL ANALYSIS OF CUTM, RAYAGADA 10

TABLE 2: ENERGY FACT FILE OF CUTM, RAYAGADA 18

TABLE 3: BUILDING AUDIT DATA OF CUTM, RAYAGADA 19

TABLE 4: CONSUMER DETAILS OF THE BUILDING 19

TABLE 5: SUMMARY OF ENERGY BILL ANALYSIS OF CUTM, RAYAGADA 20

TABLE 6: ENERGY BILL OF CUTM, RAYAGADA FOR FY' 2021-22 21

COST BENEFIT ANALYSIS:..... 23

TABLE 7: COST BENEFIT ANALYSIS FOR INSTALLATION OF CAPACITOR BANK TO IMPROVE POWER FACTOR 23

TABLE 8: CONNECTED LOAD DETAILS & CORRESPONDING kW 24

TABLE 9: DETAIL LIGHTING INVENTORY OF ALL THE UNITS OF CUTM, RAYAGADA..... 25

TABLE 10: DETAIL INVENTORY OF ACS..... 26

TABLE 11: DETAIL INVENTORY OF ALL TYPES OF FAN 26

TABLE 12: DETAIL INVENTORY OF OTHER APPLIANCES 27

TABLE 13: TECHNICAL SPECIFICATION OF TRANSFORMER..... 29

TABLE 14: TRANSFORMER PERFORMANCE ASSESSMENT 31

TABLE 14: POWER DATA 32

TABLE 19: TOTAL INDIVIDUAL LIGHTING CALCULATION OF CUTM, RAYAGADA 38

TABLE 20: COST BENEFIT ANALYSIS REPLACEMENT OF 36W FL TUBE FITTINGS WITH 20 W LED TUBE 39

TABLE 21: COST BENEFIT ANALYSIS REPLACEMENT LIGHTING LOAD IN CLASS ROOM LIGHT PIPE FITTING SYSTEM 39

TABLE 22: COST BENEFIT ANALYSIS REPLACEMENT OF LIGHTING LOAD IN SEMINAR HALL LIGHT PIPE FITTING SYSTEM..... 40

TABLE 24: COST BENEFIT ANALYSIS FOR REPLACEMENT OF 24W STREET LIGHTS WITH 50W LED SOLAR STREET LIGHT WITH ADVANCE MOTION SENSOR FACILITY 41

TABLE 25: COST BENEFIT ANALYSIS FOR INSTALLATION OF LIGHT MOTION SENSOR AT RARE OCCUPANCY AREA TO REDUCE LIGHTING LOAD 41

TABLE 17: LUX MEASUREMENT 43

TABLE 26: DETAILS OF TOTAL CONNECTED ELECTRICAL LOAD..... 44

TABLE 27: COST BENEFIT ANALYSIS OF ESTABLISHMENT OF SOLAR POWER PROJECT IN CUTM, RAYAGADA..... 45

TABLE 28: DETAIL INVENTORY OF ACS OF CUTM, RAYAGADA 47

TABLE 29: COST BENEFIT ANALYSIS OF AC 47

TABLE 30: EESL-SEAC BOQ (VOLTAS)..... 48

TABLE 31: FAN INVENTORY..... 52

TABLE 32: COST BENEFIT ANALYSIS OF FAN 52

TABLE 33: TECHNICAL SPECIFICATION OF THE DG SET..... 53

DIESEL CONSUMPTION OF 125 kVA DG SET FOR 3 YEAR IS FURNISHED BELLOW: 53

TABLE 34: DIESEL CONSUMPTION OF 125 kVA DG SET FOR FY 2021-22..... 54

TABLE 35: VEHICLE DETAIL OF CUTM, RAYAGADA..... 55

TABLE 36: COST BENEFIT ANALYSIS BY INSTALLATION OF SOLAR WATER HEATER 56



LIST OF ABBREVIATIONS

AC	: Air Conditioning
BEE	: Bureau of Energy Efficiency
LED	: Light Emitting Diode
CTR	: CT Ratio
DB	: Distribution Board
DG	: Diesel Generator
ENCON	: Energy Conservation
HRs	: Hours
HT	: High Tension
I	: Current
kL	: Kilo Liter
kV	: Kilo Volt
KVA	: Kilo Volt Ampere
kVAh	: Kilo Volt Ampere Hour
kVAR	: Kilo Volt Ampere Reactive
kW	: Kilo Watt
kWh	: Kilo Watt Hour
THD	Total harmonic distortion
LT	: Low Tension
PF	: Power Factor
PTR	: PT Ratio
SEC	: Specific Energy Consumption
TF	: Transformer
UF	: Utilization Factor
V	: Voltage



ACKNOWLEDGEMENT

M/s. Swain and Sons Power Tech Pvt. Ltd. (SSPTPL) places on record its sincere thanks to Centurion University of Technology & Management for entrusting the task of conducting the Investment Grade Energy Audit of Centurion University of Technology & Management (CUTM), Rayagada.

SSPTPL acknowledges with gratitude the wholehearted support and encouragement given by all CUTM officials while carrying out the energy efficiency study at CUTM.

SSPTPL acknowledges with gratitude and sincerely thanks all the officials and staff members of Centurion University of Technology & Management who have rendered their all-possible co-operation and assistance to the study team during the entire period of the Audit.

Our special thanks to Mr. Rajesh Kumar Padhi (Regional Director), Mr. Krushna Prasad Mohapatra (AO), Mr. R. K. Mohapatra (Principal, CPS), Mr. Chandra Sekhar Patra (Principal (SOP)) and the Energy Conservation Cell Members for their whole hearted co-operation and guidance in carrying out the Investment Grade Energy Audit of CUTM, Rayagada.

Signature



Subhranshu Sekhar Rath

General Manager

Swain & Sons Power Tech Pvt. Ltd.

Empanelled ESCO by BEE, Ministry of Power- CRISIL SME GRADING: CRISIL-BEE Grade 3

K-8-82, Kalinga Nagar, Ghatikia, Bhubaneswar-751029, Odisha

Phone: 0674-2954256

Mobile: 8093533005, 9438747172

Email: sspt12@gmail.com, info@pwrtch.com

Website: www.pwrtch.com



AUDIT TEAM DETAILS

1. Mr. Subhranshu Sekhar Rath, General Manager
2. Mr. Nilamani Behera, Sr. Consultant, Energy Auditor Regd. No. -EA-9407
3. Mr. Suresh Gurjar, Manager
4. Mr. Nirjhar Biswal, Assistant Manager (Project)
5. Mr. Suraj Kumar Bhujabala, Assistant Manager (Project)
6. Mr. Subash Mallick, Project Associate
7. Ms. Lalita Kumari Swain, Project Associate

We express our sincere thanks to the following students of CUTM, Bhubaneswar for showing their interest and involvement in conducting the energy audit of CUTM, Rayagada campus.

Sl.	Name	Enrolment No
1	Ms. Riya Saha	200301150006
2	Mr. Rohit Mishra	200301150002
3	Mr. Siddharth Singh	200301150003
4	Mr. Azharhul Haque	200301151016
5	Mr. Pradeepta Kumar Mohanta	200301150012
6	Mr. Chandrasekhar Maharana	200301151017
7	Mr. Anirban Hatui	200301150011
8	Mr. Papu Jagganath Rao	200301150007
9	Mr. B. Sai	200301151015



CERTIFICATE

We certify the following

- The data collection has been carried out diligently and truthfully.
- All data measuring devices used by the auditor are in good working condition, have been calibrated and have valid certificate from the authorized approved agencies and tampering of such devices has not occurred.
- All reasonable professional skill, care and diligence had been taken in preparing the energy audit report and the contents thereof are a true representation of the facts.
- The investment grade energy audit has been carried out in accordance with the BEE prescribed norms.

Signature



Subhranshu Sekhar Rath

General Manager

Swain & Sons Power Tech Pvt. Ltd.

Empanelled ESCO by BEE, Ministry of Power- CRISIL SME GRADING:CRISIL-BEE Grade 3

K-8-82, Kalinga Nagar, Ghatikia, Bhubaneswar-751029, Odisha

Phone: 0674-2954256

Mobile: 8093533005, 9438747172

Email: sspt12@gmail.com, info@pwrtech.com

Website: www.pwrtech.com



EXECUTIVE SUMMARY

The journey of Centurion University of Technology and Management (CUTM) started with the takeover of Jagannath Institute for Technology and Management (JITM) in 2005. Subsequently, JITM was transformed into Centurion University of Technology and Management in August 2010, through an act of Odisha Legislative Assembly CUTM (Rayagada) is situated in the mineral rich southern part of Odisha, Rayagada is a district of meadows, forests, waterfalls and terraced valleys, inhabited by many primitive tribal groups. Spread over 15 acres of land this campus provides skill integrated education in the region.

The complex includes School of Applied Sciences, School of Vocational Education and Training and School of Pharmacy.

Goals and Objectives of the Energy Management Programme:

The Investment Grade Energy Audit of Centurion University of Technology & Management, Rayagada was carried out during the period in July 2022. Energy Conservation is a major focus and requirement in Institutional, Commercial and Government Buildings, and hence the management of Centurion University of Technology & Management, has entrusted the work of conducting Investment Grade Energy Audit (IGEA) of their entire campus to Swain and Sons Power Tech Pvt. Ltd. The main focus of the audit was to establish Specific Energy Consumption for all the Buildings & Vehicles for financial year 2021-22, collection of technical information like specification of the machines, details of all the buildings, Fuel consumption in all the DG, Water consumption details, etc.

Centurion University of Technology & Management, Rayagada is availing power supply from TPSODL, local DISCOM Connections at 11 kV Voltage level and through a 250kVA, 11/0.415kV power transformer with contract demand of 206 kVA (Consumer no. 31100000076). As per electricity bills analysis for FY 2021-22, the monthly average electrical energy consumption of whole campus stands at about 6409 kWh and the monthly average energy bill is around Rs. 79969, the average Power Factor is about 0.94.



Table 1: Summary of Energy Bill Analysis of CUTM, Rayagada

SUMMARY OF THE ENERGY BILLS FOR THE LAST FINANCIAL YEAR OF CUTM RAYAGADA							
Year	Description	Electricity consumed in kWh	Avg. MD in kVA	Power Factor	Load Factor	Energy Bill in Rs.	Energy Charge in Rs./kWh
For Financial year 2021-22	Monthly average	6409	30	0.94	0.34	39803	12.97
	Daily Average	214	30	0.94	0.34	1327	12.97

The major utilities of Centurion University of Technology & Management, Rayagada are Electricity, Water and HSD. The electricity is utilized for Lighting, Fans, pumping of water, Computer, Printer, Laboratory, Water cooler, Fridge, Projector, Speaker and AC. HSD is utilized in DG set and Transportation Vehicles. Water consumption is there in all the buildings for day-to-day domestic purposes and also for plantation, gardening and cleaning.

During the study, various energy conservation options were identified, their cost benefit analysis was found out and same is furnished below. It is recommended that CUTM may implement the Energy Conservation Option as suggested in the report.

Details of Energy Conservation measures / Recommendations of Accredited Energy Auditor for Improving Energy Efficiency						
[See rule 3(1) (c)]						
Energy Saving measures	Anticipated Investment (In Lakh)	Anticipated Annual Savings (In Lakh)	Simple Pay Back Period in Year	Anticipated Annual Energy Savings		
				Electricity in kWh	Thermal Energy in mkCal	Equivalent Energy in TOE
Installation of Roof top Solar Power Plant	19.00	3.70	5.1	63247.20		5
Replacement of Old 1.5 Ton AC with EESL 1.5 ton 5 Star Super Energy Efficient AC	1.38	0.94	1.461	16111		1
Replacing 75W Conventional Ceiling Fan with Super Energy Efficient Ceiling Fan	2.55	0.72	3.5	12348		1
Replacement of 36W FL Tube Fittings with 20 W	0.05	0.05	1.1	864		0



LED Tube						
Installation of Capacitor Bank to improve Power Factor	0.20	0.50	0.40	8539		1
Replacement of lighting Load in Class Room Lightpipe Fitting System at CUTM, Rayagada	4.03	1.73	2	29568		3
Replacement of lighting Load in Seminar Hall Lightpipe Fitting System at CUTM, Rayagada	1.15	0.22	5	3802		0
Replacement of 24W Street lights with 50W LED Solar Street Light with advance motion sensor facility	0.55	0.09	6	1577		0
Installation of Light Motion Sensor at Rare Occupancy area to reduce lighting load	0.04	0.02	3	285		0
Installation of Solar Water Heater at CUTM Canteen	0.70	0.59	1		7247899	1
Total	23.18	8.57	2.71	136341	7247899	12

1.0 INTRODUCTION

The Government of India has enacted the Energy Conservation Act, 2001, with the objective of providing sustainable and more efficient management of our energy resources. The aim of Energy Conservation (EC) Act 2001 is to provide the much-needed legal framework and other institutional arrangements so that various energy efficiency improvement drives can be easily launched at the state and national level. In order to implement the various provisions under the EC Act 2001, the Government of India has established the Bureau of Energy Efficiency (BEE), to enact and enforce energy efficiency through various regulatory and promotional measures.

Energy Conservation has become a top most priority in today's scenario in order to have a sustainable growth, productivity, enhancement and Environmental Protection. Considering the vast potential of energy savings and benefits of energy efficiency as per the report prepared by National Development Council (NDC) Committee on power, Govt. of India enacted the Energy Conservation Act 2001. Accordingly, the Govt. of India set up the Bureau of Energy Efficiency (BEE) under the provision of the Energy Conservation Act 2001 for development of policies and strategies with a thrust on self-regulation and market principles, with the primary objective of reducing energy intensity of the Indian Economy.

Buildings consume significant portion of Energy for lighting, Air Conditioning, Ventilation purpose and hence Energy Conservation is a major focus and requirement in Institutional, Commercial and Government Buildings. Besides Building owners are also focusing Energy Conservation and Energy Efficiency in large extent for a higher productivity. Efficient Energy management, Usage of Energy Efficient Technologies and adopting best-practices that would help a Building Owner to reduce their energy cost considerably. Hence in order to identify the energy conservation opportunities and reduce the present energy consumption, the management of CUTM has entrusted the work of conducting Investment Grade Energy Audit (IGEA) to Swain and Sons Power Tech Pvt. Ltd. The Energy Audit of CUTM was carried out in the period of July 2022. The scope of work includes collection of existing layouts of Building,, Collection of various data including lighting inventory, AC list, Pump, Motor and other electrical load list, Collection of Month wise Energy Bill for FY 2021-22, Power measurement of all running Transformer, Panels, AC, Pump and Motor and submission of Energy Audit Report along with details of Energy Conservation Opportunity.



1.1. About The Site

The journey of Centurion University of Technology and Management (CUTM) started with the takeover of Jagannath Institute for Technology and Management (JITM) in 2005. Subsequently, JITM was transformed into Centurion University of Technology and Management in August 2010, through an act of Odisha Legislative Assembly CUTM (Rayagada) is situated in the mineral rich southern part of Odisha, Rayagada is a district of meadows, forests, waterfalls and terraced valleys, inhabited by many primitive tribal groups. Spread over 15 acres of land this campus provides skill integrated education in the region. The complex includes School of Applied Sciences, School of Vocational Education and Training and School of Pharmacy.

1.2. Scope of Works

- a) Review of present electricity consumption and fuel oil. Estimation of energy consumption in various loads like lighting, HVAC, DG Set etc. in premises of the Building.
- b) **Electrical Distribution system:**
 - Review of present electrical distribution from the single line diagram (SLD). Study of operation/loading of distribution transformers, cable loading, normal and emergency loads, electricity distribution in various area/ floors and loss estimation.
 - Study of reactive power management and option for power factor improvement, functioning of capacitor banks.
 - Study of power quality, like harmonics, current unbalance, voltage unbalance etc.
 - Exploring the energy conservation options (ENCON) in the electrical distribution system.
- c) **Lighting System**
 - Review of present lighting system, lighting inventories etc.
 - Estimation of lighting load at various locations like different floors, outside (campus) light, pump house and other important locations.
 - Detailed illuminations survey with measurement of LUX level at various locations and comparison with acceptable standards.
 - Study of present lighting control system, lighting maintenance systems, present procedure for management of lighting spares and consumables and recommendation for improvement
 - Analysis of lighting performance indices like LUX/m² LUX/Watt, LUX/Watt/m² and comparison of the same with benchmark.
 - Exploring the possibility of retrofitting option with energy efficient lighting system like LED lamp, control Gears, sensors and automators, voltage regulators and solar based system.



- Developing a suitable lighting energy accounting and monitoring system.
- Exploring the energy conservation options (ENCON) in lighting system.

d) Heating Ventilation & Air conditioning system (HVAC system)

- Review of present HVAC system like Split AC, Window AC, water coolers and air heater etc.
- Performance assessment of window AC, and Split AC
- Analysis of HVAC performance like estimation of Energy Efficiency Ratio (EER) i.e. (KW/TR) and comparison of the operating data with the design data and recommendation for best prices/standard requirement.
- Exploring the energy conservation options (ENCON) in HVAC system

e) Diesel Generators (DG) sets

- Review of DG set operation
- Performance Assessment of DG sets in terms of specific fuel consumption (SFC i.e., kWh/Ltr.), Exploring the energy conservation options (ENCON) in lighting system.
- Exploring the energy conservation options (ENCON) in DG sets.

f) Water pumping system

- Review of water pumping, storage and distribution systems.
- Performance assessment of all major water pumps i.e. power consumption vs. flow delivered, estimation of pump efficiency etc and compare with best practices
- Study the flow control mechanism.
- Study of rational utilization of water pumping system, energy efficient retrofitting etc.

g) Motor Load survey

- Conducting the motor load survey.
- Survey of motor loading (% loading) for major electrical drives
- Measurement of all electrical parameters like voltage, current, PF & KW for all running motors and calculation of pump efficiency and suggestion for improvement.
- Study of mechanical power transmission system and suggest for energy efficiency
- Study of rational usage of drives for reducing electrical energy consumption.

h) Energy Monitoring & Accounting System:

- Detail Review of present energy monitoring & accounting system in terms of metering, record keeping, data logging, periodic performance analysis etc.
- Suggest for procedures for improvement in energy monitoring and accounting system.



i) UPS

- Measurement and analysis UPS loading, redundancy, operating efficiency, load pattern to suggest measures for energy cost reduction, measurement and analysis of Harmonic.

j) Others:

- Review of present maintenance practice, replacement policies and building safety practices as applicable to high rising buildings and recommend for improvement.
- Cost benefit Analysis of each ENCON indicating simple payback period, return of investment (ROI) internal rate of return (IRR)

1.3. Methodology

The following step by step methodology and approach were adopted to carry out the Investment Grade Energy Audit Report of CUTM, Rayagada. Prior to energy audit, SSPTPL team made a walk-through survey of the building and associated subsystems to assess the followings: -

- The existing layout of Building.
- Collection of various data including lighting inventory, AC list, Fan list, Motor and other electrical load list.
- Collection of Month wise Energy Bill for FY 2021-22.

The methodology was explained / discussed with CUTM, Rayagada officials. The broad methodology adopted for the Energy Audit at CUTM is furnished below.

1. The program of visit of energy audit team to site for carrying out the IGEA work was informed to CUTM, Rayagada officials.
2. Data collection and Energy Bill Collection was carried out through discussions with the officials and from past records, log books.
3. Technical specification of equipments and their operating parameters were collected, while visiting the area. The data so collected were analyzed and the deviations were noted.
4. Performance of the major energy consuming equipments was analyzed.
5. Measurement of electrical energy parameters, wherever possible, using portable instruments were carried out.
6. Power Measurement of all running Transformer, Panels, AC was carried out using portable power analyzer brought by SSPTPL for this purpose.
7. Review of present lighting system, lighting inventories collection were carried out. Estimate all lighting load at various locations like different parts of Building, outside area i.e. street lighting and area lighting and other important locations. Also detailed illuminations survey was determined with measurement of LUX level at various locations.



8. Ambient parameters (Temperature, Humidity) were measured using portable test instrument brought by SSPTPL.
9. Energy Conservation option were identified and tabulated on the basis of priority.
10. Draft soft copy of energy audit report comprising of observations and recommendations with adequate financial justification, vendor support data, etc. was prepared and submitted to CUTM, Rayagada for acceptance.
11. Final energy audit report was submitted after acceptance of the draft energy audit report.

1.4. Instruments Used

SSPTPL have a wide array of latest, sophisticated, portable, diagnostic and measuring instruments to conduct energy audit investigations and analysis. The following special portable instruments are used to carry out various field measurements and analysis during the energy audit period.

- Three Phase Power Analyzer(ALM-30)
- Clamp on electrical power analyzers
- Infrared Non-Contact Thermometer
- Anemometer
- Hygrometer
- LUX Meter
- Power Guard

2.0 BRIEF DESCRIPTION OF THE UNIVERSITY

Name & Address

Centurion University of Technology & Management Rayagada
Pitamahal, Rayagada, Odisha- 765002
Tel: 9437095990

Name & Details of Authorized Signatory of CUTM, Rayagada

Mr. Rajesh Kumar Padhi (Regional Director)
Mobile: 9437095990
E-mail: rajeshkumar.padhi@gmail.com

Name & Details of Project Coordinator

Mr. Krushna Prasad Mohapatara (AO)
Mobile: 7328810147

DESCRIPTION OF CAMPUS:

Centurion University of Technology & Management (CUTM) Rayagada is situated in the mineral rich southern part of Odisha. Rayagada is a district of meadows, forests, waterfalls and terraced valleys, inhabited by many primitive tribal groups. Spread over 15



acres of land this campus provides skill integrated education in the region. It is located at latitude 19°08'12"N & longitude 83°24'49"E. Nearest Railway station is Rayagada junction.

The complex includes School of Applied Sciences, School Of Vocational Education and Training and School of Pharmacy. University is having approximately 60 numbers of teaching staff members, 400 numbers of Students, 47 numbers of non-teaching staffs.

Centurion University of Technology & Management, Rayagada was availing power supply from TPSODL, local DISCOM Connections contract demand of 40kW (Consumer no. 311001080060). But from July 2021, CUTM, Rayagada is availing power supply with a contract demand of 206kVA (consumer No-311000000076). One number of DG Set i.e. DG Set-1 (125kVA) is also present for providing power supply in emergency situation.

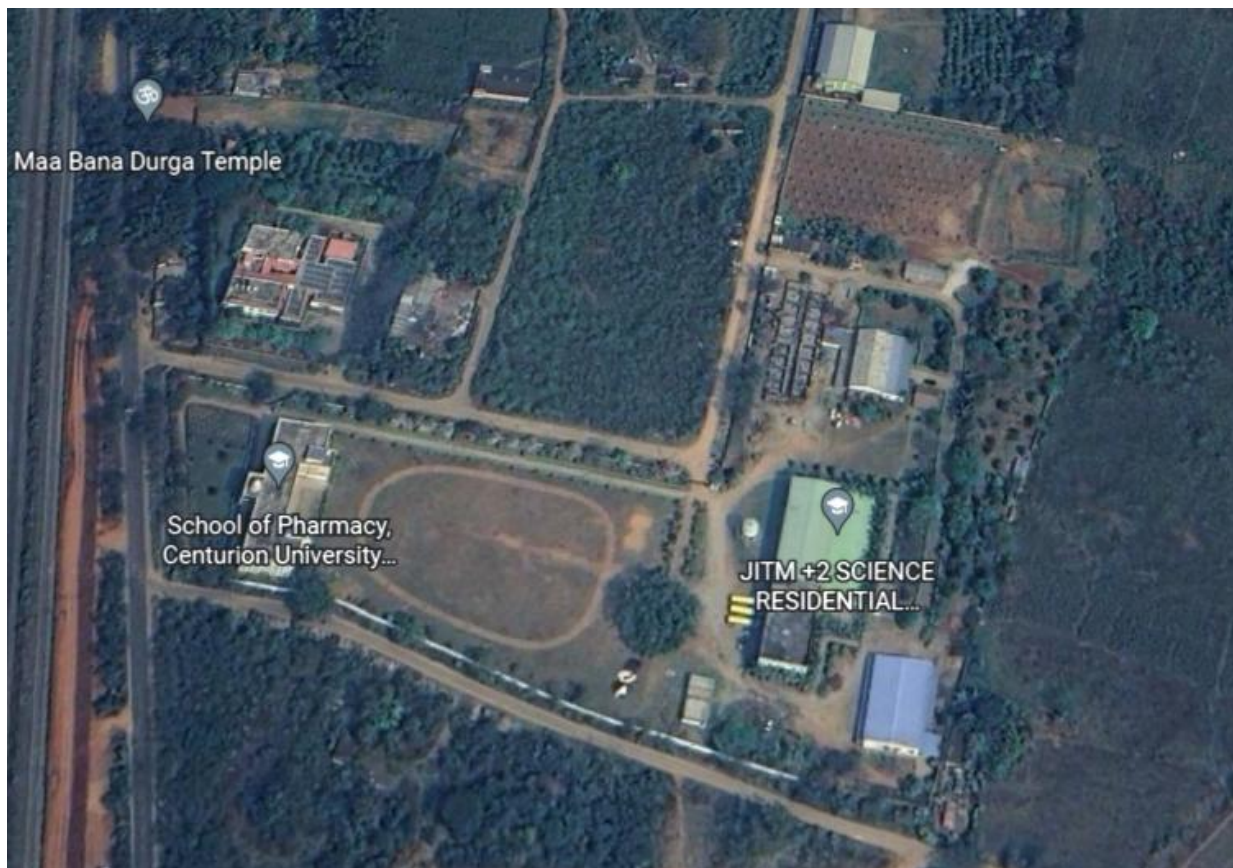

(Google Earth View of CUTM, Rayagada)

2.1 Major Utility

- Electricity
- Water
- HSD

Electricity:

Electricity is utilized for Lighting, Fans, Pumping of water, Computer, Printer, Laboratory, Water cooler, Fridge, Projector, Speaker and AC, etc.



Water:

Water consumption is in all the Buildings for day to day usage and also utilized in plantation, gardening and cleaning.

HSD:

HSD is consumed in DG set and Transportation.

3.0 ENERGY SCENARIO

CUTM receives the electrical power supply from TPSODL at 11kV. The present contract demand of the Building with TPSODL is 206 kVA. The energy fact file of the building is furnished below:

Table 2: Energy Fact File of CUTM, Rayagada

Location	Centurion University of Technology & Management (CUTM), Pitamahal, Rayagada, Odisha-765002
Areas of Utilization of Energy	CUTM, Rayagada
Source of Supply	11KV Distribution Line from Rayagada Substation of TPSODL
Total Contract Demand	206kVA
Major Loads	Lighting & Power, Air Conditioning, Heating & Cooling, Computers, Printers, Fans, Pump, Motor, DG Set , Household Appliances and Other loads
Usage Hours	Mainly 09.00 am to 6.00 pm on all working days
Monthly Energy Consumption	Avg. 6409 kWh per Month based on FY 2021-22
Monthly Energy Bill	Avg. Rs. 79969 per month based on FY 2021-22



Table 3: Building Audit Data of CUTM, Rayagada

Building Audit Data Sheet			
Sl. No.	Item	Value	
Size, Age & Construction of the building			
1	Connected Load or Contract Demand in kVA	206 kVA	
2	Installed Capacity: DG Sets (KVA or KW)	125	
3	a) Annual Electricity Consumption ,Purchased From Utilities(kWh)	64089	
	Annual Electricity Consumption, Through Diesel Generating DG Set (kWh)	NA	
	c) Total Annual Electricity Consumption, Utilities + DG Sets (kWh)	64089	
4	a) Annual Cost Electricity Purchased from Utilities (Rs.)		
5	Working hours (Mainly day working but Library is 24 hour working)	Built Up Area (sq m) (Excluding Basement Area)	6216
6	Working days/week (e.g. 5/6/7 days per week)		6
7	Installed lighting load(kW)		5
8	Installed capacity of Air Conditioning System (TR)		25.50
9	Existing EPI(Energy performance Index) in kWh/sq. m/year Energy includes		10.35
	Electricity Purchased & Generated (Excluding Electricity from any Renewable Source)		64089
10	No. of Floors in the building		2
11	HSD		24003.35
	consumption in DG/GG sets		770.866
12	Occupancy Information	Daily Visitors	45
		Staff Members	107

3.1 Analysis of Energy Bill

The energy bills details and tariff categorization details of CUTM, Rayagada for FY' 2021-22 having consumer no- 311000000076 is furnished below:

Table 4: Consumer details of the Building

Consumer Name & Address	SRI RAJESH KUMAR PADHI, CENTURION ITC(JITM)TRUST PITAMAHAL, RAYAGADA
Tariff Category	GENERAL PURPOSE>=110KVA
Consumer No.	311000000076
Contract Demand	206kVA
Supply Voltage	11kV



Data source: Energy Bills of CUTM were collected during the period of Energy audit. The summary of Energy Bill Analysis of CUTM, Rayagada is furnished below:

Table 5: Summary of Energy Bill Analysis of CUTM, Rayagada

The summary of Energy Bill Analysis of CUTM, Rayagada Building is furnished below:

SUMMARY OF THE ENERGY BILLS FOR THE LAST FINANCIAL YEAR OF CUTM RAYAGADA							
Year	Description	Electricity consumed in kWh	Avg. MD in kVA	Power Factor	Load Factor	Energy Bill in Rs.	Energy Charge in Rs./kWh
For Financial year 2021-22	Monthly average	6409	30	0.94	0.34	39803	12.97
	Daily Average	214	30	0.94	0.34	1327	12.97

Note: We collected the bill for FY' 2021-22 for the purpose of analysis as in earlier financial year the consumption was low due to COVID-19 and institution is in partial closed condition.

Table 6: Energy Bill of CUTM, Rayagada for FY' 2021-22

SUMMARY OF ENERGY BILL OF THE CUTM FOR FINANCIAL YEAR 2021-22																				
Month	Energy Consumed in kWh	Energy Consumed in kVAh	Av. Load Factor	Av. Power Factor	MD in kW	MD in kVA	Energy Charge in Rs.	Demand Charge in Rs.	PF Penalty (+ve) / PF Incentive (-ve)	Rebate	CSC	TOD Incentive	Overdrawl Penalty	Delay Payment Surcharge	Interest on Security	Meter Rent in Rs.	Electricity Duty	Current Monthly Bill in Rs.	Energy Charge in Rs./kWh	Unit cost in Rs. per kWh
Apr-21	9556	10619	0.32	0.90	40.00	44.444	61206.18	11111	0	727	250	0	0	585	0	150	4896	78199	9	8.2
May-21	3093	3299	0.10	0.94	41.67	44.444	19299.15	11111	0	308	250	0	0	696	971	150	1544	33050	11	10.7
Jul-21	3816	4082	0.27	0.93	18.70	20	23879.7	41200	0	662	250	176	0	0	0	1000	1896	68050	18	17.8
Aug-21	5532	5855	0.41	0.94	18.14	19.2	34195.18	41200	0	764	250	275	0	174	0	1000	2714	79257	15	14.3
Sep-21	7054	7364	0.33	0.96	29.89	31.2	43079.17	41200	0	852	250	317	0	541	0	1000	3421	89174	13	12.6
Oct-21	6416	6736	0.23	0.95	38.10	40	39402.91	41200	0	816	250	300	0	1542	0	1000	3128	86323	14	13.5
Nov-21	7280	7661	0.39	0.95	25.70	27.04	44813.4	41200	0	869	250	317	0	2665	0	1000	3560	93171	13	12.8
Dec-21	6040	6495	0.47	0.93	17.41	18.72	37991.07	41200	0	801	250	330	0	2726	0	1000	3013	85850	15	14.2
Jan-22	4392	4779	0.46	0.92	12.79	13.92	27952.7	41200	0	701	250	260	0	825	0	1000	2215	73182	17	16.7
Mar-22	10910	11320	0.39	0.96	37.78	39.2	66214.22	41200	0	1082	250	493	0	0	0	1000	5258	113429	11	10.4
Total / Av.	64089	68209	0.34	0.94	28	30	398033.68	351822	0	7582	2500	2468	0	9754	971	8300	31645	799687	13	12
Monthly Average	6409	6821	0.34	0.94	28	30	39803	35182	0	758	250	247	0	975	97	830	3165	79969	13	12
Daily Average	214	227	0.34	0.94	28	30	1327	1173	0	25	8	8	0	33	3	28	105	2666	13	12

From the Energy Bill of FY 2021-22 it is observed that Average Demand in this year is 28kW with an Average Power Factor of 0.94.



Figure 1: Trend of Energy Consumption of CUTM, Rayagada

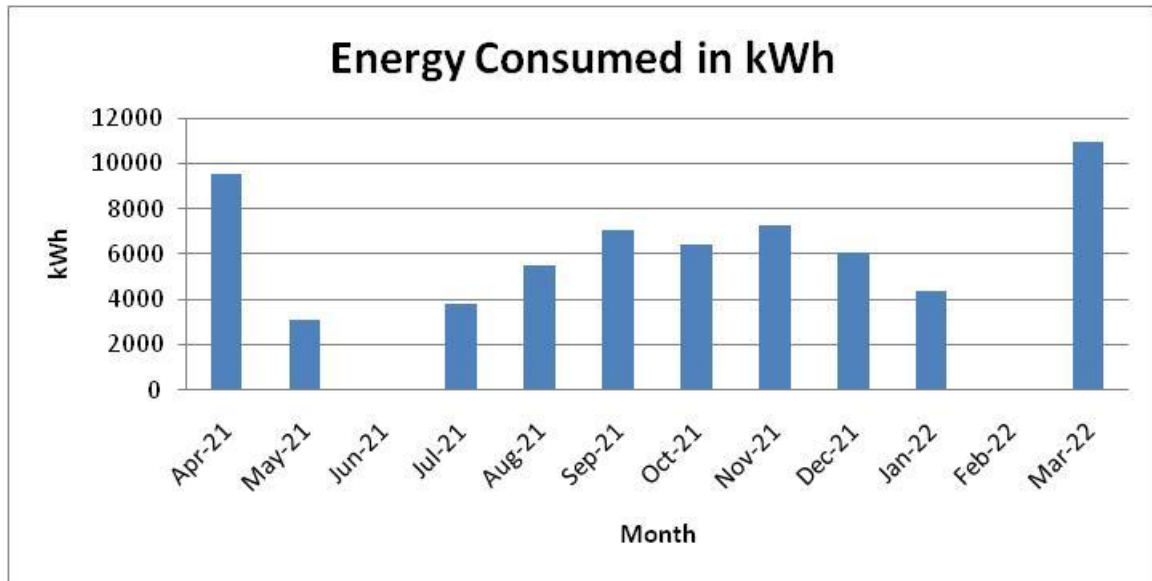
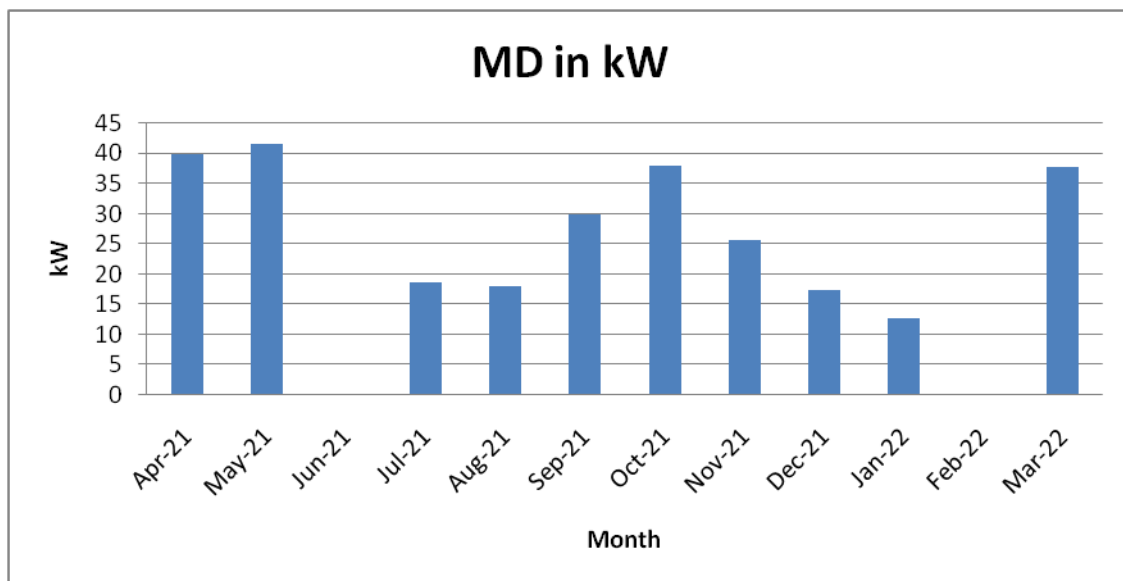

Figure 2: Trend of MD of CUTM, Rayagada



**Energy Conservation Option:****Background:**

Based on analysis of electricity bill it was observed that the power factor of CUTM, Rayagada is 0.94. So it is recommended to install capacitor bank to improve the power factor. In this project the annual energy saving will be 8539 kWh, investment required will be 0.2 lacs and annual financial savings will be 0.5 lacs with simple payback period around 4 months.

Cost Benefit Analysis:**Table 7: Cost Benefit Analysis for Installation of Capacitor Bank to improve Power Factor**

Cost Benefit Analysis for Installation of Capacitor Bank to improve Power Factor		
Particulars	Unit	Value
Average Power	kW	28.02
Present Power Factor		0.94
To be Power Factor		1
Phi-1	Degree	20.10
Phi-2	Degree	0.00
Required Capacitor Bank	kVAR	10.25
Capacitor Required	kVAR	10.00
Initial KVA	kVA	29.83
Final kVA	kVA	28.02
Run Hour / Day	HR/Day	13.00
Annual kVAh Saved	kVAh	8626
Annual kWh Saved Considering @ PF 0.99	kWh	8539
Annual Energy Saving	TOE	1
Annual Financial Savings due to Capacitor Bank	Lacs	0.5
Investment Required	Lacs	0.2
Simple Pay Back Period	Years	0.4

3.2 Base Line Energy Consumption and Specific Energy Consumption

During our audit it is seen that the load drawl pattern of CUTM, Rayagada is typical of a unit functioning in day time but the Hostel and Admin building, are functioning beyond office hours. At night time minimum illumination inside the building and full outside lighting with street-lights are maintained. The office working hours in CUTM, Rayagada is from 9 AM to 6PM normally for 300 days in a year. During the office period normal loads are room lighting, fans, ACs and office appliances. During the entire office working hours the load remains steady with small variations.



Connected load details & corresponding kW consumption

From the inventory survey, it is estimated that there is a connected load of about 49.85 kW in CUTM, Rayagada. It may be seen that the lighting load constitutes about 10 % of the total load, the Fan load constitutes about 30% of the total load, the other load constitutes about 9% of the total load and air conditioning loads share about 51% of the total connected load. The following table indicates the estimated connected load details.

Table 8: Connected load details & corresponding kW

Summary of Electrical Load	
Load Centre	Killo Watt
Lighting	4.927
Fan	14.76
AC	25.500
Other Load	4.665
Total	49.852

Figure 3: Pie Chart of Connected Load Details & Corresponding kW Consumption

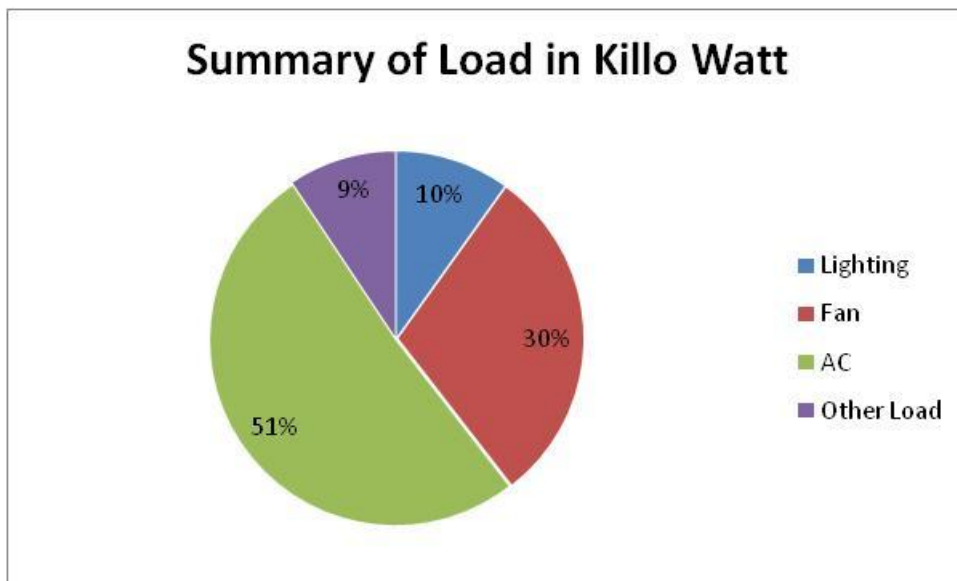

**Table 9: Detail lighting inventory of all the units of CUTM, Rayagada**

Lighting Inventory				
Area Name	Types of Load	Wattage of each load in Watt	Nos. installed	Total connected Wattage in Watt
Old Building Ground Floor	Led Tube Light	20	30	600
	Fluorescent Light	36	11	396
Old Building First Floor	Pendant Light	40	14	560
	LED Tube Light	16	14	224
	Fluorescent Light	43	1	43
Pharmacy Ground Floor	LED Bulb	9	42	378
Pharmacy First Floor	LED Bulb	9	30	270
Pharmacy Second Floor	LED Bulb	9	26	234
Kids(Boys Hostel-1)	Fluorescent Light	36	4	144
	LED Tube Light	20	17	340
Boys Hostel-2	LED Tube Light	20	32	640
Canteen	LED Tube Light	20	23	460
	LED Bulb	9	2	18
Seminar Hall	Ceiling Spot Light	9	20	180
	LED Spot Light	100	2	200
Street	Street Light	24	10	240
Total			278	4927



Table 10: Detail Inventory of ACs

AC Inventory					
Area Name	Watt	Rated Tonnage	Number	Tonnage	Total load in kW
Old Building Ground Floor	1500	1.5	9	13.50	13.50
Old Building 1st Floor	1500	1.5	1	1.50	1.50
Pharmacy Building Ground floor	1500	1.5	2	3.00	3.00
Pharmacy Building 1st Floor	1500	1.5	1	1.50	1.50
Seminar Hall	1500	1.5	4	6.00	6.00
Total			17	25.50	25.50

Table 11: Detail Inventory of All Types of Fan

Fan Inventory				
Area Name	Types of Load	Wattage of each load in Watt	Nos. installed	Total connected Wattage in kW
Old Building Ground Floor	Ceiling Fan	75	40	3
Old Building 1st Floor	Ceiling Fan	75	14	1.05
	Wall Fan	35	8	0.28
Pharmacy Ground floor	Ceiling Fan	75	29	2.175
Pharmacy 1st Floor	Ceiling Fan	75	24	1.8
Pharmacy 2nd Floor	Ceiling Fan	75	20	1.5
Kids hostel -1	Stand Fan	50	7	0.35
	Ceiling Fan	75	9	0.675
Boys hostel 02	Ceiling Fan	75	32	2.4
Canteen	Wall Fan	35	3	0.105
	Ceiling Fan	75	13	0.975
Street light around the campus	Ceiling Fan	75	6	0.45
Total			90	14.76



Table 12: Detail Inventory of other appliances

Other Inventory of CUTM RAYAGADA				
Building Name	Equipment	Watt	Quantity	Total connected Wattage in kW
Kids Hostel 01	CCTV	15	2	0.03
	Cooler	150	1	0.15
Canteen	CCTV	15	6	0.09
	Exhaust	35	1	0.035
	Vacuum Cleaner	100	1	0.1
	Potato Chopper	450	1	0.45
	Mixer Grinder	500	2	1
	Oven	2000	1	2
	Cooler	150	2	0.3
Seminar Hall	Projector	150	1	0.15
	Smart Screen	150	1	0.15
	CCTV	15	2	0.15
	Speaker Sound System	30	2	0.06
Total				4.7

3.3 Electrical Distribution System and Water Distribution System

The Power Supply system of CUTM, Rayagada was studied and based on the observations; the Single Line Diagram of Existing Electrical distribution system of CUTM is drawn and furnished below.



Figure 4: Electrical Distribution System

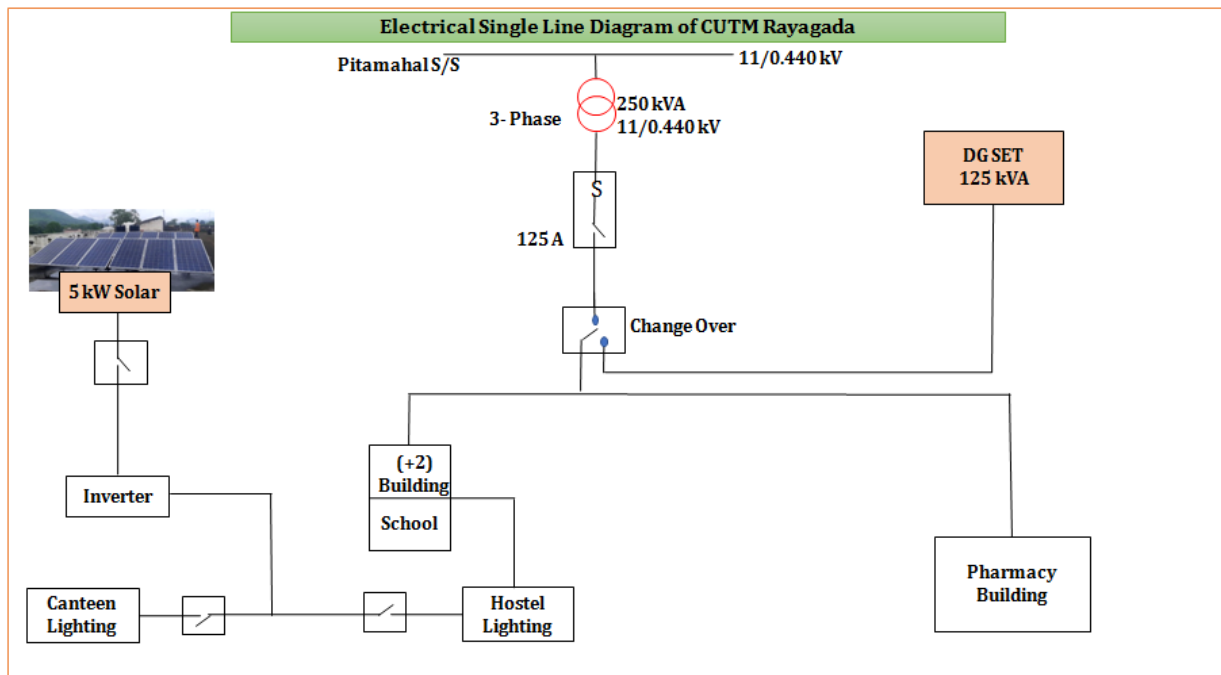
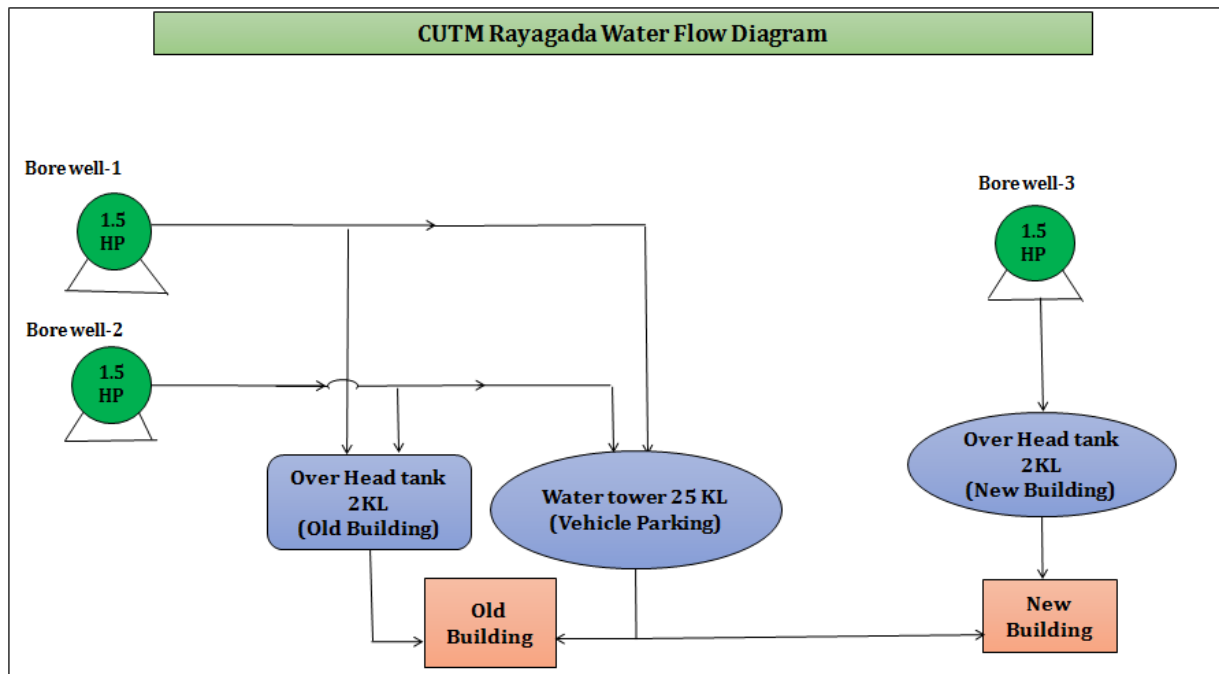

Figure 5: Water Distribution System





3.4 Transformer Details

The technical specification of transformer and its % loading is furnished below:

Table 13: Technical Specification of Transformer

Technical data sheet of CUTM, Rayagada Transformers	
Particulars	Main Transformer
Make	M/s. Gram Tarang Employability Training Services Pvt. Ltd.
Transformer rated in kVA	250
Rated voltage ratio in kV	11/0.44
Rated current ratio in Amp	13.12/333.34
No. of phase	3.00
Vector diagram	Dyn-11
Type of cooling	ONAN



250kVA Transformer

***Note:** (The transformer area should be cleaned properly and also fencing is not done)



(Transformer Earthing Point)

***Note:** The transformer area earthing point is not clean. It should be maintained properly.

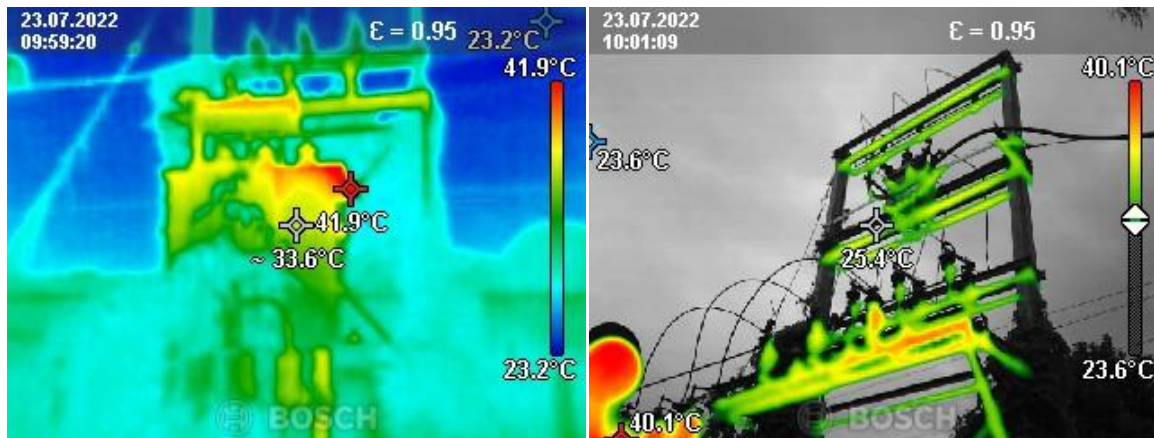

(Thermography photograph of Transformer)

The power measurement of the transformer is carried out by 3 phase power analyzer. The results are attached in Annexure. Based on Average Power measurement data the transformer loadings and efficiency are calculated and furnished below.

**Table 14: Transformer Performance Assessment**

Technical data sheet of CUTM, Rayagada Transformers	
Particulars	TRF 250kVA
Make	M/s. Gram Tarang Employability Training Services Pvt. Ltd.
Transformer rated in kVA	250
Rated voltage ratio in kV	11/0.440
Rated current ratio in Amp	13.12/333.34
No. of phase	3.00
Vector diagram	Dyn-11
Type of cooling	ONAN
Measured voltage at LT side in kV	0.41
Measured current LT Side in Amp	17.32
Measured Power Factor	0.93
No Load Loss (kW)	0.64
Full Load Loss of Transformer (kW)	4.45
Measured load (kVA)	12.34
% Loading on the Transformer (Measured kVA/ Rated kVA)	4.94
Actual Losses of Transformer (kW)	0.65
Total Actual Power Delivered by Transformer in kW	11.47
Transformer Efficiency, %	94.63
Transformer performance	Satisfactory



Table 14: Power Data

BUILDING POWER MEASUREMENT									
SL. No.	Area	Incoming/Outgoing	Phase	Voltage in (V)	Current in (A)	PF	kW	Unbalance Voltage (V) in %	Unbalance Current (I) in %
1	Main Building	Outgoing	R	230.2	23.9	0.99	18.37	0.07%	54.19%
			Y	230.4	12.8	0.99			
			B	230.5	9.8	0.99			
2	School of Pharmacy	Outgoing	R	228.5	12.6	0.99	6.23	0.07%	137.74%
			Y	228.6	0	0.99			
			B	228.8	3.3	0.99			
3	Transformer	Outgoing	R	410.1	9.4	0.98	29.87	0.62%	34.11%
			Y	413.8	16.6	0.98			
			B	409.8	16.8	0.98			
4	DG Set	Outgoing	R	407.1	24.8	0.98	52.93	0.60%	34.20%
			Y	406.4	17.7	0.98			
			B	403.1	34.4	0.98			

Power measurement was carried out at the various outgoing cable emanating from the distribution board of each transformer and the results are tabulated below.

3.5 Study of Voltage, Current, Power Factor Profile

Trend of Output voltage profile, Current profile, Output Power profile, Power Factor profile, Voltage Unbalance of Load Distribution is furnished below.



Table 15: Voltage Variation and %Unbalance of 250 kVA Transformer- CUTM, Rayagada

Voltage Variation and %Unbalance of 250 kVA Transformer- CUTM , Rayagada						
Date	Time	Frequency	Phase-1 RMS	Phase-2 RMS	Phase-3 RMS	Vunb
		Hz	V	V	V	%
7/23/2022	10:24:00 AM	50.03	410.1	413.8	409.8	0.006
7/23/2022	10:24:05 AM	50.03	410.4	413.5	410.3	0.005
7/23/2022	10:24:10 AM	50.03	410.7	413.7	410.6	0.005
7/23/2022	10:24:15 AM	50.02	410.7	413.5	410.4	0.005
7/23/2022	10:24:20 AM	50.03	410.7	413.6	410.6	0.005
7/23/2022	10:24:25 AM	50.03	410.7	413.3	410.7	0.004
7/23/2022	10:24:30 AM	50.03	410.6	413.3	410.5	0.004
7/23/2022	10:24:35 AM	50.03	410.7	413.4	410.6	0.004
7/23/2022	10:24:40 AM	50.02	410.6	413.1	410.9	0.004
7/23/2022	10:24:45 AM	50.02	410.8	413.2	411.1	0.004
7/23/2022	10:24:50 AM	50.02	410.6	413.2	411	0.004
7/23/2022	10:24:55 AM	50.01	410.4	412.9	410.7	0.004
7/23/2022	10:25:00 AM	50.01	410	412.6	410.1	0.004
7/23/2022	10:25:05 AM	50.01	409.9	412.6	409.9	0.004
7/23/2022	10:25:10 AM	50	409.5	412.5	409.6	0.005
Average Voltage & %Unbalance			411.37			0.004

Figure 6: Trend of Voltage Variation of 250 kVA Transformer- CUTM Rayagada

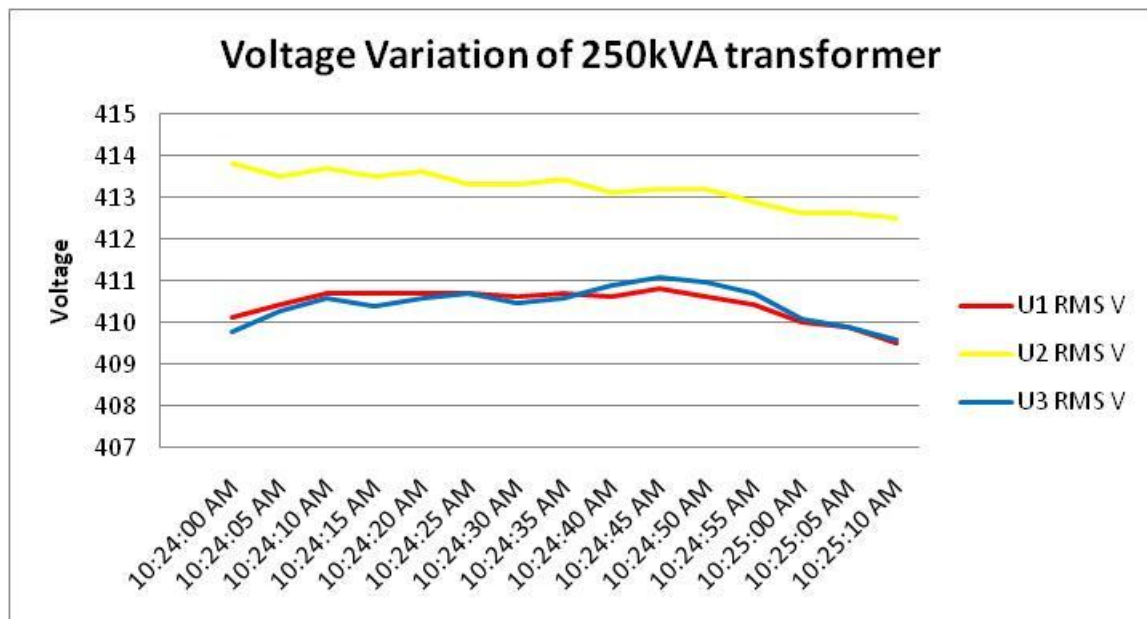



Table 16: Current Variation and %Unbalance of 250kVA Transformer- CUTM, Rayagada

Current Variation and %Unbalance of 250 kVA Transformer -CUTM Rayagada						
Date	Time	Frequency	A1 RMS	A2 RMS	A3 RMS	Aunb
		Hz	A	A	A	%
7/23/2022	10:24:00 AM	50.03	9.4	16.6	16.8	4.9
7/23/2022	10:24:05 AM	50.03	9.3	16.6	16.7	4.9
7/23/2022	10:24:10 AM	50.03	9.3	16.8	16.7	5.0
7/23/2022	10:24:15 AM	50.02	9.8	17.0	16.8	4.7
7/23/2022	10:24:20 AM	50.03	9.3	16.8	16.8	5.0
7/23/2022	10:24:25 AM	50.03	9.3	16.8	18	5.4
7/23/2022	10:24:30 AM	50.03	9.9	16.8	18.3	5.1
7/23/2022	10:24:35 AM	50.03	11.8	16.8	18.6	3.9
7/23/2022	10:24:40 AM	50.02	12.8	16.7	27.5	6.2
7/23/2022	10:24:45 AM	50.02	15.9	16.7	28.3	4.4
7/23/2022	10:24:50 AM	50.02	18.5	16.7	27.8	4.3
7/23/2022	10:24:55 AM	50.01	17.2	16.7	27.5	3.8
7/23/2022	10:25:00 AM	50.01	17.4	16.7	27.3	3.8
7/23/2022	10:25:05 AM	50.01	18.9	16.7	27.4	4.3
7/23/2022	10:25:10 AM	50	17.4	16.7	27.6	3.9
Average Current & %Unbalance			17.72			4.6



Figure 7: Trend of Current Variation and %Unbalance of 250 kVA Transformer- CUTM Rayagada

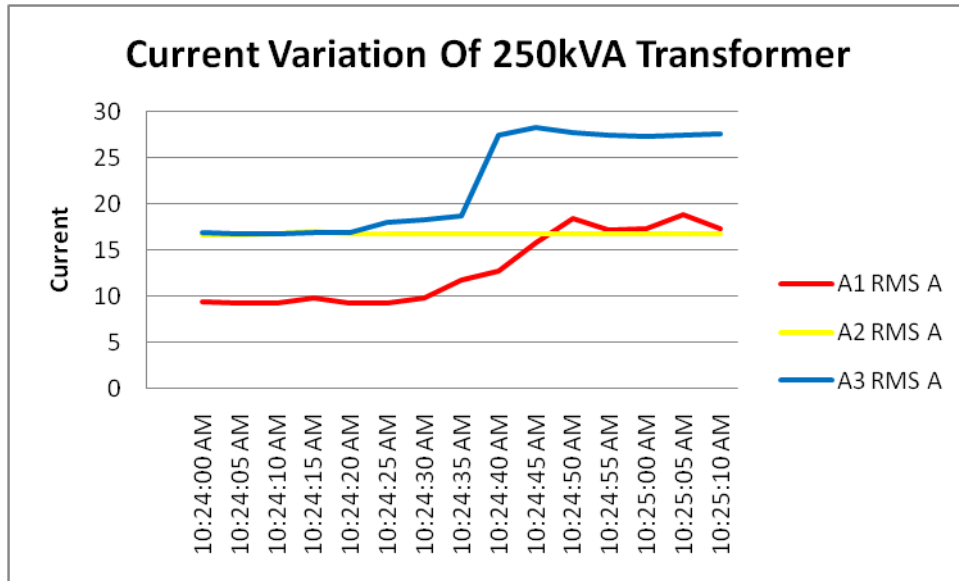

Table 17: Average Power Factor of 250 kVA Transformer –CUTM Rayagada

Average Power Factor of 250 kVA Transformer -CUTM Rayagada						
Date	Time	Frequency	PF1	PF2	PF3	PF Mean
		Hz	Ph-1	Ph-2	Ph-3	Avg.
7/23/2022	10:24:00 AM	50.03	0.96	0.96	0.83	0.917
7/23/2022	10:24:05 AM	50.03	0.96	0.96	0.83	0.916
7/23/2022	10:24:10 AM	50.03	0.96	0.96	0.83	0.914
7/23/2022	10:24:15 AM	50.02	0.95	0.96	0.83	0.914
7/23/2022	10:24:20 AM	50.03	0.95	0.96	0.82	0.913
7/23/2022	10:24:25 AM	50.03	0.95	0.96	0.83	0.915
7/23/2022	10:24:30 AM	50.03	0.95	0.96	0.82	0.911
7/23/2022	10:24:35 AM	50.03	0.97	0.96	0.82	0.917
7/23/2022	10:24:40 AM	50.02	0.98	0.97	0.9	0.949
7/23/2022	10:24:45 AM	50.02	0.96	0.97	0.92	0.95
7/23/2022	10:24:50 AM	50.02	0.99	0.97	0.92	0.957
7/23/2022	10:24:55 AM	50.01	0.99	0.97	0.91	0.955
7/23/2022	10:25:00 AM	50.01	0.98	0.97	0.91	0.953
7/23/2022	10:25:05 AM	50.01	0.98	0.97	0.91	0.953
7/23/2022	10:25:10 AM	50	0.98	0.97	0.91	0.953
Average Power Factor						0.93



Figure 8: Trend of Power Factor of 250kVA Transformer –CUTM Rayagada

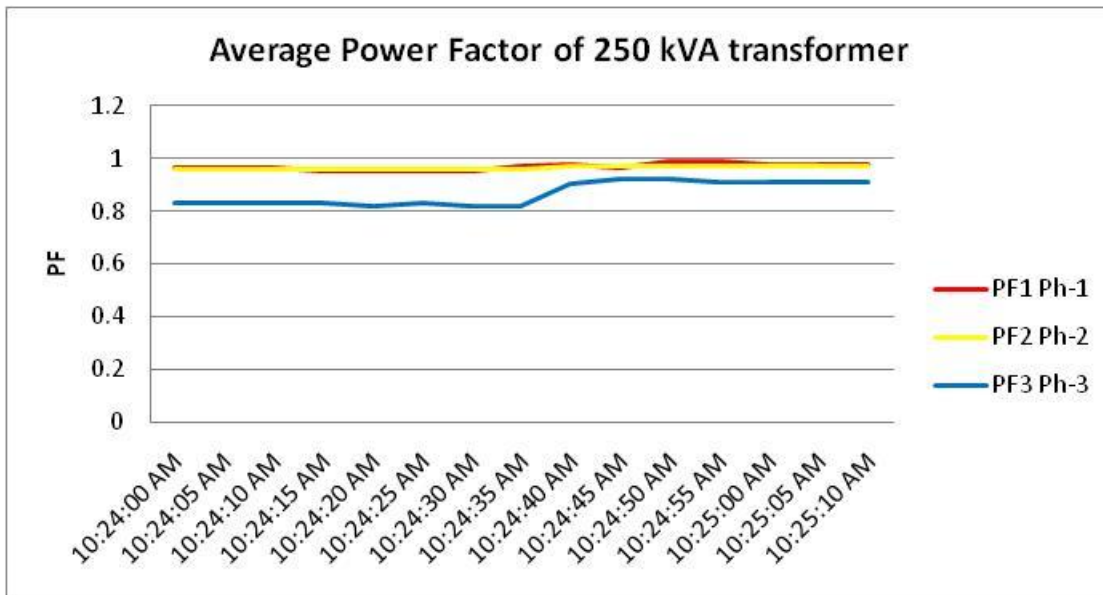
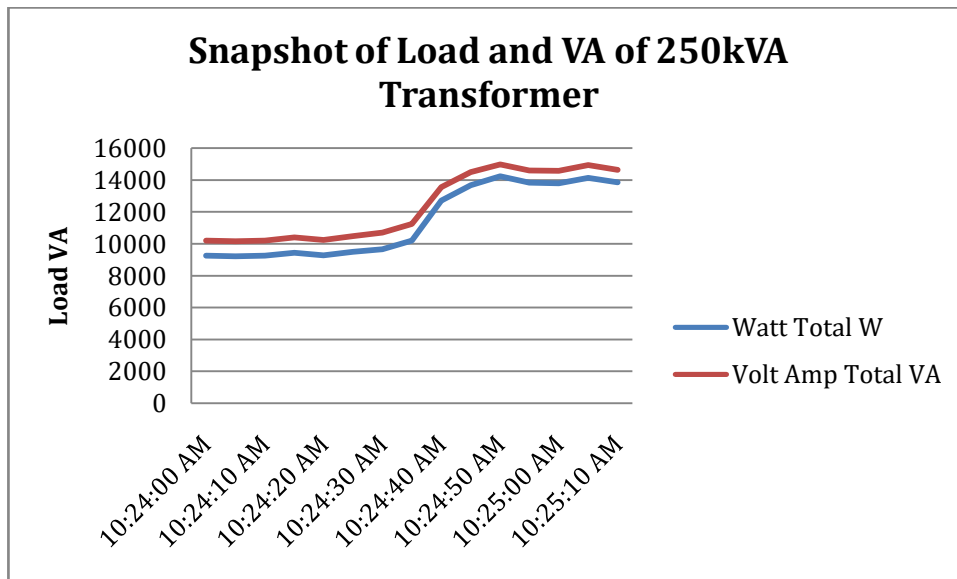

Table 18: Snapshot of Load in (W & VA) of 250 kVA Transformer-CUTM Rayagada

Snapshot of Load in (W & VA) of 250 kVA Transformer-CUTM Transformer				
Date	Time	Frequency	Watt Total	Volt Amp Total
		Hz	W	VA
7/23/2022	10:24:00 AM	50.03	9270.9	10186
7/23/2022	10:24:05 AM	50.03	9222	10155
7/23/2022	10:24:10 AM	50.03	9255.3	10198
7/23/2022	10:24:15 AM	50.02	9436.7	10395
7/23/2022	10:24:20 AM	50.03	9284.3	10236
7/23/2022	10:24:25 AM	50.03	9505	10483
7/23/2022	10:24:30 AM	50.03	9663.1	10700
7/23/2022	10:24:35 AM	50.03	10202	11234
7/23/2022	10:24:40 AM	50.02	12724	13552
7/23/2022	10:24:45 AM	50.02	13683	14506
7/23/2022	10:24:50 AM	50.02	14248	14981
7/23/2022	10:24:55 AM	50.01	13837	14595
7/23/2022	10:25:00 AM	50.01	13807	14578
7/23/2022	10:25:05 AM	50.01	14153	14944
7/23/2022	10:25:10 AM	50	13866	14649
Average			11477	12359



Figure 9: Trend of Load & VA of 250kVA Transformer-CUTM, Rayagada



4.0 LIGHTING SYSTEM

4.1 Lighting Inventory

Adequate and proper lighting contributes both directly and indirectly towards productivity and safety, and towards providing an improved work atmosphere. In fact, all these are inter-related and complimentary to each other. There are several factors, which contribute towards proper lighting. However, all efforts were made to study and include these factors during audit of CUTM for lighting loads.

To study, analyze and identify energy conservation options in lighting, a study of the building lighting load was conducted. The purpose of the study was to determine the lighting load and its distribution in various sections of the Building, determine the quality of illumination provided, and recommend measures to improve illumination and reduce electricity consumption.

A high quality and accurate digital LUX meter was used to measure the illumination level at various sections of the building during working hours. Other performance indicators such as type of lamps used, type of luminaries, physical condition of lamps and luminaries, use of day lighting, etc. was also noted down.

During the study, measurement of lighting loads, voltage conditions, phase balancing in the facility areas were carried out. The illumination level was also measured primarily at various classrooms and common areas of the building. Care was taken to reduce the effect



Investment Grade Energy Audit of CUTM, Rayagada

of day lighting while taking the measurements. The recorded inventory is enclosed in tabular form.

To determine the quantity of lighting load a physical count of the light fittings in CUTM, Rayagada was carried out. Further, the inputs from the officials and maintenance log books were taken into consideration for calculating the inventory of total light fittings of the CUTM. The total connected load of lighting in CUTM is about 4.90kW. The summarized lighting installations are furnished below.

Table 19: Total individual lighting calculation of CUTM, Rayagada

Lighting Inventory				
Area Name	Types of Load	Wattage of each load in Watt	Nos. installed	Total connected Wattage in Watt
Old Building Ground Floor	LED Tube Light	20	30	600
	Fluorescent Light	36	11	396
Old Building First Floor	Pendant Light	40	14	560
	LED Tube Light	16	14	224
	Fluorescent Light	43	1	43
Pharmacy Ground Floor	LED Bulb	9	42	378
Pharmacy First Floor	LED Bulb	9	30	270
Pharmacy Second Floor	LED Bulb	9	26	234
Kids(Boys Hostel-1)	Fluorescent Light	36	4	144
	LED Tube Light	20	17	340
Boys Hostel-2	LED Tube Light	20	32	640
Canteen	LED Tube Light	20	23	460
	LED Bulb	9	2	18
Seminar Hall	Ceiling Spot Light	9	20	180
	LED Spot Light	100	2	200
Street	Street Light	24	10	240
Total			278	4927



Energy Conservation Option:

Background:

It is observed that there is a scope in energy conservation in lighting system by replacing 36W FL Tube Fittings with 20W LED Tube light. The annual energy saving will be 864 kWh and financial saving will be around Rs. 0.5 Lakh & investment required will be Rs.0.54 Lakh with simple payback period of 1.1 Year.

Table 20: Cost Benefit Analysis for Replacement of 36W FL Tube Fittings with 20 W LED Tube light

Cost Benefit Analysis for Replacement of 36W FL Tube Fittings with 20 W LED Tube		
Particulars	Unit	Value
Total no. of 36 W FL Tube Fittings	Nos.	15
Total no. of 20W LED Tube Fittings Required	Nos.	15
Present Lighting Load	kW	1
Future Lighting Load After Implementation	kW	0.30
Saving in Load	kW	0.240
Run Hour/day	hr	12
Annual Energy Saving	kWh	864
Annual Energy Saving	TOE	0.1
Annual Cost of Savings @ Rs. 5.85/unit	Rs.	5054
Investment Required	Rs.	5460
Simple Payback Period	Year	1.1

Background:

It is observed that there is a scope in energy conservation in lighting system by installation of Light pipe Fitting System in class room. By using light pipe system the annual energy saving will 29568 kWh and financial saving will be around Rs.1.73 Lakh & investment required will be Rs. 4.03 Lakh with simple payback period of 2 Years.

**Table 21: Cost Benefit Analysis Replacement lighting Load in Class Room Light pipe Fitting System**

Cost Benefit Analysis Replacement of lighting Load in Class Room Light pipe Fitting System at CUTM, Rayagada		
Particulars	Unit	Value
Nos. of Rooms	Nos.	14
Total Nos. of 20W Light Fittings in Class Room and Labs	Nos.	70
Operating Hour	Hours	8
Avoidance of expected Lighting Load per Annum	kW	11.2
Nos. of Light Pipe System to be Installed	No.	35
Nos. of Light Pipe System to be Installed in each room	Nos.	3
Annual Energy Saving @330 Days	kWh	29568
Annual Energy Saving	TOE	2.54
Annual Financial Saving	Rs. in Lakh	1.73
Investment Required	Rs. in Lakh	4.03
Simple Payback Period	Year	2

Background:

It is observed that there is a scope in energy conservation in lighting system by Installation of Light pipe Fitting System in Seminar Hall. By using light pipe system the annual energy saving will 3801 kWh and financial saving will be around Rs.0.22 Lakh & investment required will be Rs. 1.15 Lakh with simple payback period of 5.2 Years.

Table 22: Cost Benefit Analysis Replacement of lighting Load in Seminar Hall Light pipe Fitting System

Cost Benefit Analysis Replacement of lighting Load in Seminar Hall Light pipe Fitting System at CUTM, Rayagada		
Particulars	Unit	Value
Total Nos. of 9W Light Fittings in Seminar Hall	Nos.	20
Operating Hour	Hours	8
Avoidance of expected Lighting Load per Annum	kW	1.44
Nos. of Light Pipe System to be Installed	No.	10
Annual Energy Saving @330 Days	kWh	3801.6
Annual Energy Saving	TOE	0.33
Annual Financial Saving	Rs. in Lakh	0.22
Investment Required	Rs. in Lakh	1.15
Simple Payback Period	Year	5.2



Background:

It is observed that there is a scope in energy conservation in lighting system by replacement of 24W street lights with 50W LED solar lights with motion sensor technology. By using solar light with motion sensor the annual energy saving will be 1577 kWh and financial saving will be around Rs.9224 & investment required will be Rs. 0.55 Lakh with simple payback period of 6 Years.

Table 24: Cost Benefit Analysis for Replacement of 24W Street lights with 50W LED Solar Street Light with advance motion sensor facility

Cost Benefit Analysis for Replacement of 24W Street lights with 50W LED Solar Street Light with advance motion sensor facility		
Particulars	Unit	Value
Total no. of 24 W Street Lights	Nos.	10
Total no. of Solar Street Lights Required	Nos.	10
Present Lighting Load	kW	0.36
Future Lighting Load After Implementation	kW	0.00
Saving in Load	kW	0.360
Run Hour/day	hr	12
Annual Energy Saving	kWh	1577
Annual Energy Saving	TOE	0.14
Annual Cost of Savings @ Rs. 5.85/unit	Rs.	9224
Investment Required	Rs.	55330
Simple Payback Period	Year	6

Background:

There is a scope in energy conservation in lighting system by installing Light Motion Sensor at Rare Occupancy area which shall reduce lighting load. By using motion sensor, the annual energy saving will 285 kWh and financial saving will be around Rs. 1668 & investment required will be Rs. 4248 with simple payback period of 2.55 Years.

**Table 25: Cost Benefit Analysis for Installation of Light Motion Sensor at Rare Occupancy area to reduce lighting load**

Cost Benefit Analysis for Installation of Light Motion Sensor at Rare Occupancy area to reduce lighting load		
Particulars	Unit	Value
Total no. of existing 20 W LED fitting at Dining hall, Kitchen store	Nos.	21
Total no. of existing 9 W LED fitting at Skill Lab	Nos.	12
Present Lighting Load	kW	0.53
Future Lighting Load After installation motion sensor considering @15% saving	kW	0.4
Saving in Load	kW	0.1
Run Hour/day	hr	12
Annual Energy Saving	kWh	285
Annual Energy Saving	TOE	0.02
Annual Cost of Savings @ Rs. 5.85/unit	Rs.	1668
Investment Required	Rs.	4248
Simple Payback Period	Year	2.55

4.2 O & M Practice, Energy Accounting and Monitoring For Lighting System

CUTM electrical maintenance team looks after the operation & maintenance of electric supply, ventilation & air conditioning, lighting system etc. The works involves maintenance of Lighting system, Light replacement, Switching on/off of street light. Solar Street light system installed and maintained by CUTM engineers. But now days the Timers are available and the electricians are switching on/off the street lighting by manually. It is recommended to install Timer in the Street Light Circuit.

It is observed that there is no proper document available for keeping the records of lighting maintenance, LUX survey, lighting inventory list, area wise lighting consumption etc. A set of well designed format for lighting system record keeping may be developed and maintained at the earliest.

Proper lighting inventory list to be maintained, further during any replacement of lighting system, same may be simultaneously updated in the inventory.

The Monitoring and Targeting programs have been so effective that they show typical reductions in annual energy costs between 5% and 20%.

The essential elements of M&T system are

- Recording: Measuring and recording energy consumption.
- Analyzing: Correlating energy consumption to actual energy consumption
- Comparing: Comparing energy consumption to an appropriate standard or benchmark.
- Setting Targets: Setting targets to reduce or control energy consumption.



- Monitoring: Comparing energy consumption to the set target on a regular basis.
- Reporting: Reporting the results including any variances from the targets which have been set.
- Controlling: Implementing management measures to correct any variances, which may have occurred.

4.3 Illumination Survey and LUX Level Measurement

The Illumination survey and Electrical Equipment Inventory List of the CUTM Building including Corridor were carried out by measuring the LUX of the different area, Lab, Office Room, Auditorium, Street Light and Class Room using LUX meter, by physical counting of inventory and the results are tabulated below.

Table 17: LUX Measurement

LUX Measurement		
Area	Measured LUX	Recommended LUX
Dining Hall	55	200-300-500
Staff Room	65	50-100-150
Class Room	50-55-60-70	200-300-500
Principal Office	65,70	50-100-150
AO Office	65,70	50-100-150
Computer LAB	65,70	200-300-500
Chemistry LAB	70,75	200-300-500
Skill LAB	70,75	200-300-500
Seminar Hall	75,80	200-300-500
Street Light	45	50-100-150

4.4 Energy Conservation Option

It was observed that LUX level of street lights at different location are between 5 to 8 which is not satisfactory. Since there is less occupancy & less movement in the street light area during night time, so the low LUX level is not causing any difficulties

The periodic checking of load unbalances should be carried out so as to limit the unbalance less than 10%.



It is suggested to conduct periodic LUX level survey (preferably once in 3 months) and maintain record properly. Necessary corrective actions should be taken periodically.

Awareness among staff, student and control room operators is to be created for improvement in all aspects of energy conservation especially relating to lighting in their respective wings.

4.5 Electrical Load Distribution

In CUTM, Rayagada apart from lighting load there are different types of electrical load likes fans, Computers, Printers, TVs, Geyser, Fridge and other home appliance etc. The summary of connected electrical load is furnished below.

Table 26: Details of Total Connected Electrical Load

Summary of Electrical Load	
Load Centre	Kilowatt
Lighting	4.927
Fan	14.76
AC	25.500
Other Load	4.665
Total	49.85

4.6 UPS & Ventilation

At the time of audit period it is observed that there is no major power consuming UPS system in CUTM.

Energy saving Opportunity:

It is recommended to keep the monitors of the computers in standby mode rather in screen saver mode to reduce the power consumption of the computers when not in use. It is difficult to quantify the saving on account of this measure. The investment will be zero and simple payback period will be immediate.

ENCON Option for Installation of Solar Power Plant in Net Metering Concept

Concept of Net Metering:

Net metering is the concept which records net energy between export of generated energy and import of DISCOM energy for a billing month. Alternatively, the meter, having the feature of recording both the import and export values, also are generally allowed for arriving net energy for the billing period.

**Principle of net metering:**

Based on available roof area / ground area solar PV panels will be installed. The output of the panels (DC electricity) will be connected to the power conditioning unit / inverter which converts DC to AC. The inverter output will be connected to the control panel or distribution board of the building to utilize the power. The inverter synchronizes with grid and also with any backup power source to produce smooth power to power the loads with preference of consuming solar power first. If the solar power is more than the load requirement, the excess power is automatically fed to the grid. For larger capacity systems connection through step up transformer and switch yard will be used to feed the power to grid.

Advantages of net metering:

The grid connected roof top / ground mounted solar PV system would fulfill the partial / full power needs of large-scale buildings. The following are some of the benefits of roof top SPV systems:

- Generation of environmentally clean energy
- Consumer becomes generator for his own electricity requirements
- Reduction in electricity consumption from the grid
- Reduction in diesel consumption wherever DG backup is provided
- Feeding excess power to the grid

It is recommended that after installation of Roof Top at CUTM, Rayagada, the annual energy generation will be 63247 kWh, annual cost saving will be Rs. 4 Lakh. Around Rs. 19 Lakh of investments will be required and payback period shall be 5.1 years.

Table 27: Cost Benefit Analysis of Establishment of Solar Power Project in CUTM, Rayagada

Installation of Roof top Solar Power Plant		
Units Generation	Unit	Value
Total Annual Energy Consumed from TPCODL in FY 2021-22	kWh	64089
Average Base Demand from TPCODL	kW	7
Proposed capacity of the Solar Power Project to be installed	kW	38.506
Total Area Required	Sq. ft.	4620.69
Total Area Available	Sq. ft.	8751
Maximum Solar Project feasible	kW	73
Proposed capacity of the Solar Power Project to be installed	kW	38
Total Project Cost Required	Rs. Lakh	19
Capacity Utilization Factor	%	0.19
Net Annual Generation	kWh	63247
Annual Energy Saving	TOE	5.44
Weighted Average Rate of Electricity	Rs./kWh	5.85
Annual Saving in Energy Bills due to Consumption from own solar power	Rs. Lakh	4
Simple Payback Period	Years	5.1



Implementation:

1. The total project cost to be borne by the consumer, however consumer is eligible for any subsidy / grant from State Govt. / Central Govt. / MNRE as applicable from time to time Implementation of net metering facility shall be made applicable for the consumers having 3-phase supply service connection.
2. Protection system including its switch gear to be certified by concerned Ex. Engineer and harmonic suppressive device to be installed by such SPV generator to suppress the harmonics injection as harmonics is more in case of solar plants where conversion of DC to AC is taking place. Islanding protection requirements to be provided.
3. The SPV generator shall provide the indication of solar PV plant at the injection point for easy identification to the operating personnel.
4. The SPV generator needs to get statutory approvals from appropriate authority like Electrical Inspector for the connected equipment including its solar panels.
5. The proposed generator shall submit the prescribed application to the concerned Executive Engineer of local DISCOM who should be nodal authority for approval of the same.
5. The net meter / meter to be used for arriving net energy shall have the specifications prescribed.
6. Concerned JE of DISCOM shall issue a technical feasibility certificate and witness the synchronization of SPV plant with distribution network.
7. 0.5 class accuracy, tri-vector based energy meter, non ABT having the MRI downloading facility along with related accessories shall have to be installed by the SPV generator as per the specifications of DISCOM.
8. Spot billing is to be arranged by concerned DISCOM as per the billing period. DISCOM shall arrange to develop suitable software and incorporate in the billing instrument for such billing.

It is recommended to install 38 kW Solar Project in CUTM, Rayagada.

5.0 HVAC System

At present, the air conditioning system in the CUTM is met through window /split AC of following number.

There are around 17 numbers of air conditioning systems present in CUTM, Rayagada

It is estimated that there is about 25.50 kW of AC load in CUTM contributing to about 51% of the total connected load.

Installed Air conditioning System of CUTM are furnished below:

**Table 28: Detail Inventory of ACs of CUTM, Rayagada**

AC Inventory					
Area Name	Watt	Rated Tonnage	Number	Tonnage	Total load in kW
Old Building Ground Floor	1500	1.5	9	13.50	13.50
Old Building 1st Floor	1500	1.5	1	1.50	1.50
Pharmacy Building Ground floor	1500	1.5	2	3.00	3.00
Pharmacy Building 1st Floor	1500	1.5	1	1.50	1.50
Seminar Hall	1500	1.5	4	6.00	6.00
Total			17	25.50	25.50

5.1 Energy Conservation Option

Installation of AC Saver for old 1.5 ton AC

Recommendation:

It is recommended to install AC Saver for the existing 1.5 Ton ACs. After installation of AC Saver, the annual energy saving will be 16111kWh, annual cost saving will be Rs. 0.942 Lakh. Around Rs. 1.4 Lakh of investment will be required and payback period shall be 1.5 years.

Table 29: Cost Benefit Analysis of AC

Cost Benefit Analysis for Installation of AC Saver for Old 1.5 Ton AC		
Particular	Unit	Value
Present nos. of 1.5 Ton AC	Nos.	17
Total Capacity	TR	25.5
Av. Electrical Load of each existing AC before Replacement	kW	1.755
Total Av. Electrical Load before Replacement	kW	29.835
Annual Energy consumption before implementation	kWh	107406
Annual Energy consumption after implementation of AC Saver assuming @15% saving	kWh	91295
Annual Energy Saving due to Installation of AC Saver	kWh	16111
Annual Energy Saving	TOE	1.39
Annual Cost of Savings @ Rs.5.85/unit	Rs. Lakh	0.942
Investment required	Rs. Lakh	1.4
Simple payback period	Years	1.5

Based on future requirements, the old 1.5 Ton ACs should be replaced with EESL Super Efficient ACs.



Table 30: EESL-SEAC BOQ (Voltas)

EESL-SEAC BOQ (Voltas)		
Sl.N o.	Descriptions of Item	
1	Supply of 1.5 TR split inverter AC, Rated ISEER 5.4. energy efficient 5 Star AC. (indoor unit, outdoor unit, remote control)	1 No.s
a	Refrigeration Piping(Copper) for 1.5 TR Hi wall Unit- (RMT)	3
b	Electrical Cable - (RMT)	3
c	Drain Pipe - (RMT)	3
2	No of Preventive Maintenance Service in a Year	2



Star Rating	Stars	5
Cooling Capacity Full Load (100%)	W	5280
Cooling Capacity Half Load (50%)	W	2640
Cooling Power Full Load (100%)	W	1310
Cooling Power Half Load (50%)	W	433
ISEER		5.4
Power Supply	V/Hz/Ph	230 / 50 / 1 Phase
Air Flow Volume - Indoor	CMH	950
*Noise Level - Indoor	..dB(A)	≤46
Operation		LCD Remote
Compressor Type		High EER Twin Rotary - BLDC
Wide Operating Voltage Range	V	145~270
Max operating Ambient Temp Range	Deg C	52 ⁰ C
Refrigerant Gas		R32
Indoor Unit Dimension	mm	990x315x242



(WxHxD)			
Indoor Unit Net / Gross Weight		Kg	13.5/16.5
Outdoor Unit Dimension (WxHxD)		mm	870x600x355
Outdoor Unit Net / Gross Weight		Kg	33.5/39
Connecting Pipe		type	Cu-Cu(12.5mm & 6.35mm)
Connecting Pipe Length		Meter	3.0
Connecting Cable		Meter	3.0
Condenser Coil			Fin & Tube
No of boxes		ODU	1 Box
		Connecting Tube	
		IDU	1 Box
Features	Filter	Anti Dust	Yes
		Catechin Filter	Yes
		Acaro Bacterium	Yes
		Silver Ion	Yes
	IDU Fin	Hydrophylic Aluminum	Blue
		Copper tubes	Inner Grooved
	IDU	LED Display	Yes
		Self Diagnosis	Yes
		Anti Fungal	Yes
		5D Concept	Yes
		Auto Restart	Yes
	Remote	Sleep Mode	Yes
		Turbo	Yes
		Swing	Yes
		LCD Remote	Yes
		Lock	Yes
		Timer	Yes
		Glow Buttons	Yes
	Air Vent	Dual Temp Display	Yes
		Cross Flow	Yes

* Noise level reflects the levels in Anechoic Chamber
 All above performance data are as per IS 1391 Rated conditions

No Derating in cooling capacity at 43 degree Celsius



Cost per AC (For Consumer) in INR – (1 Year Comprehensive Warranty & 5 Year Warranty on Compressor)				39990
Miscellaneous Cost				Voltas
1	Additional warranty for one year i.e. for 2nd year post the expiry of the standard one year warranty ; inclusive of GST	Unit		2200
2	Additional warranty for one year i.e. for 3rd year post the expiry of the standard one year warranty ;inclusive of GST	Unit		2400
3	Copper Pipe ; inclusive of GST	Per Meter		600
4	EPPDM Rubber Insulation for refrigerant piping ; inclusive of GST	Per Meter		90
5	Power Cable ; inclusive of GST	Per Meter		120
6	Drain Pipe ; inclusive of GST	Meter		100
7	Buyback of old Acs ; inclusive of GST	Unit		2500
8	Additional warranty for 4 year (Inclusive of GST)			4000

5.2 Advantages of Inverter Air Conditioner

The latest and the most efficient technology that is available in market today is the Inverter Technology for air conditioners. Inverter technology is designed in such a way that it can save 30-50% of electricity (units consumed) over a regular air conditioner.

Inverter air conditioners are more powerful, offer great savings and are better at maintaining temperature compared to non-inverter air conditioners. When compressor needs more power, it gives it more power. When it needs less power, it gives less power. With this technology, the compressor is always on, but draws less power or more power depending on the temperature of the incoming air and the level set in the thermostat. The speed and power of the compressor is adjusted appropriately.

Let's take an example of 1.5 Ton inverter air conditioner versus non-inverter air conditioner

A 1.5 Ton inverter air conditioner works initially at 1.7 Ton and as the desired temperature is achieved it reduces its capacity to 1.5, 1 or 0.3 Ton based on room conditions.

A 1.5 Ton non-inverter air conditioner on the other hand works at 1.5 Ton all the times.

Every air conditioner is designed for a maximum peak load. So a 1.5ton AC is designed for a certain size of room and 1 ton for a different size. But not all rooms are of same size. A regular air conditioner of 1.5ton capacity will always run at peak power requirement when the compressor is running. An air conditioner with inverter technology will run continuously but will draw only that much power that is required to keep the temperature stable at the level desired. So it automatically adjusts its capacity based on the requirement of the room it is cooling. Thus, drawing much less power and consuming lesser units of electricity.



5.3 Maintenance Tips for Split / Window AC

- Make sure AC doesn't get overloaded; check the fuse or circuit breaker if it doesn't operate.
- Remember to replace or clean the filter and have your mechanic clean the evaporator and condenser coils regularly, for the air conditioner to cool the home efficiently.
- Install a programmable thermostat, it will lead to 10-15% energy saving.
- Set the thermostat as high as possible comfortable.
- Set the fan speed on high except on very humid days, when humidity is high set the fan speed on low for more comfort.
- Install units in shade, it will lead to 10% saving in energy consumption.
- Use sun films on windows. That will cut heat entry by 70% of the building.
- If the AC makes noise it needs to be checked by the mechanic
- A good air filter will extend the life of the air conditioner because the important parts, like the cooling coil, and other inner parts will stay cleaner, operate more efficiently and last longer.
- Avoid frequent opening of doors/windows. A door kept open can result in doubling the power consumption of your AC.
- Ensure direct sunlight (and heat) do not enter the air-conditioned space, particularly in the afternoons.
- Most people believe that a thermostat set to a lower temperature than desired, will force air-conditioner to cool faster, not really, all it does, is make air-conditioner operate for longer. Moreover, it will result in unnecessarily chilly room and wasted power. Every degree lower on the temperature setting results in an extra 3-4% of power consumed. Hence, once a comfortable temperature found then set the thermostat at that level, avoid touching the thermostat thereafter.
- Once an air-conditioning system has been designed and installed avoid any major change in the heat-load on the AC. This will add to wasted power.
- Always ensure that whenever new unit is installed, make sure its EER (12/(kW/TR)) should be between 9.5 to 10.5.
- No gap should be left during installing units for cool air escape.



6.0 Fan Inventory

Table 31: Fan Inventory

Fan Inventory				
Area Name	Types of Load	Wattage of each load in kW	Nos. installed	Total connected Wattage in kW
Old Building Ground Floor	Ceiling Fan	75	40	3
Old Building 1st Floor	Ceiling Fan	75	14	1.05
	Wall Fan	35	8	0.28
Pharmacy Ground floor	Ceiling Fan	75	29	2.175
Pharmacy 1st Floor	Ceiling Fan	75	24	1.8
Pharmacy 2nd Floor	Ceiling Fan	75	20	1.5
Kids hostel -1	Stand Fan	50	7	0.35
	Ceiling Fan	75	9	0.675
Boys hostel 02	Ceiling Fan	75	32	2.4
Canteen	Wall Fan	35	3	0.105
	Ceiling Fan	75	13	0.975
Street light around the campus	Ceiling Fan	75	6	0.45
Total			90	14.76

6.1 Energy Conservation Option

It is observed that there is a scope in energy conservation in fan system by replacing Conventional Ceiling Fans with 26W Energy Super Efficient Fans. By using recommended fan the annual energy saving will be 12348 kWh and financial saving will be around Rs. 72236 & investment required will be Rs. 2.54 Lakh with simple payback period of 3.5 Years.

Table 32: Cost Benefit Analysis of Fan

Cost Benefit Analysis for replacing 75W Conventional Ceiling Fan with Super Energy Efficient Ceiling Fan		
Particulars	Unit	Value
Total No. of Fans Operating	Nos.	90
Present Load before Replacement @ 75W per Fan	kW	6.8
Load after Replacement @ 26 W Energy Efficient Super Fan	kW	2.3
Saving in Load	kW	4.4
Run hour /Day	hr	8.0
Annual Energy Saving Assuming 350 Days	kWh	12348.0
Annual Energy Saving	TOE	1.1
Annual Cost of Savings @ Rs. 5.85/unit	Rs.	72236
Total Investment Required	Rs.	254790
Simple Payback Period	Years	3.5



7.0 DIESEL GENERATING (DG) SET

7.1 Observation & Analysis for DG Set

There is one no. of DG sets of 125 kVA capacity installed in CUTM to meet the power requirement of the major areas of the building in case of power supply failure from TPSODL.

The technical specification of the DG Set is furnished below:

Table 33: Technical specification of the DG set

Technical Specification of DG	
Particulars	DG Set 1
Make	GENESIS
Capacity in kVA	125
Phase	3
Rated Voltage in Volt	440
Rated Current in Amp	173.91
Rated PF	0.8
Rated Speed in RPM	1500
Date of Mfg	19-08-2011
Rated Fuel Consumed in Liter/Hour	3



Diesel Consumption of 125 kVA DG Set for the last year is furnished bellow:



Table 34: Diesel Consumption of 125 kVA DG Set for FY 2021-22

Month	Diesel Consumption in KL
Apr-21	0.098
May-21	0.052
Jun-21	NA
Jul-21	NA
Aug-21	0.145
Sep-21	0.084
Oct-21	0.074
Nov-21	0.144
Dec-21	0.063
Jan-22	0.006
Feb-22	NA
Mar-22	0.105
Total	0.771

7.2 Recommendation

- The DG sets are normally operated in power failure condition and in any emergency load requirement case.
- The details of energy generated and consumption of Diesel for both the DG set is not being recorded presently for which the specific energy consumption of DG set could not be evaluated.
- So it is recommended that the DG set generation and HSD consumption details are to be noted monthly basis in log book for future reference and evaluation of SEC.
- Both the DG set should be inspected by Electrical Inspector; Energy Meter should be installed across the DG set and sealed properly in consultation with Chief Electrical Inspector.
- The record of energy generated in DG set is not available. It is to be recommended that energy meter is to be installed in each DG set and the energy generated in each DG set has to be recorded to calculate the specific energy consumption of DG set.

8.0 TRANSPORTATION

It is observed that the University has 4 numbers of buses, 2 numbers of four-wheelers for transportation. The fuel consumption of the vehicles for the last year is mentioned bellow.

**Table 35: Vehicle Fuel Detail of CUTM, Rayagada**

Vehicle fuel Summary 21-22			
Month	Monthly Fuel Expenses	Monthly Unit Price	Monthly Oil Consumption in Liters
Apr-21	136496	88	1551.09
May-21	6382	87	73.36
Jun-21	64318	92	699.11
Jul-21	101577	96	1058.09
Aug-21	168811	97	1740.32
Sep-21	167165	96	1741.30
Oct-21	143613	98	1465.44
Nov-21	169271	107	1581.97
Dec-21	195529	91	2148.67
Jan-22	103042	91	1132.33
Feb-22	133227	91	1464.03
Mar-22	230348	91	2531.30
TOTAL			17187.01

Recommendation:

It is recommended that either replace the lower efficiency vehicles with Electric Vehicles or they may be operated for smaller distances.

9.0 WATER PUMPING SYSTEMS**9.1 Water Pumping Storage and Distribution System**

CUTM meets its water requirement from Ground water through sump storage facility, the pump motors is having various connections like both single and 3-phase connection.

9.2 Utilization of water Pumping System

There are submersible types of pumps installed in CUTM for the auxiliary consumption of water like housekeeping, gardening etc. There are 3 nos. of 1.5 HP bore well pumps,

9.3 Mechanical Power Transmission Study and Rational Usages of Drives

There are submersible types of pumps installed in CUTM for the auxiliary consumption of water like housekeeping, gardening etc. Though these are submersible type pump, hence the study of mechanical power system could not be carried out and hence no recommendation is furnished for the same. It is recommended that in future flow meter to be installed and water consumption to be monitored.



9.4 Rain Water Harvesting System

The rainwater harvesting system is one of the best methods practiced and followed to support the conservation of water. Today, scarcity of good quality water has become a significant cause of concern. It is recommended that RWH system may be installed for water conservation.

9.5 Sewage Treatment Plant

The campus has no sewage treatment plants for the primary Treatment and management of sewage generated in the campus including its hostel and residential area. It is recommended to install Sewage treatment plant so that treated water can be used for gardening purposes inside the campus. The use of treated water will reduce the ground water use and additionally the treated sludge will be very useful increasing the fertility of the soil.

9.6 Financial Benefit by Installation of Solar Water Heater

It is recommended to install Solar Water Heater for 500 Liters of water. By installing Solar Water Heater, annual LPG saving @300days will be 630kg, annual cost saving will be Rs. 0.59 Lakh. Around Rs. 0.70 Lakh of investment will be required and payback period shall be 1.19 years.

Table 36: Cost Benefit Analysis by Installation of Solar Water Heater

Cost Benefit Analysis of Installation of Solar Water Heater at CUTM Canteen		
Particulars	Unit	Value
Hot Water for Canteen per Day by Solar Water Heater	Ltr	500
Consumption of LPG for heating Water	Kg	2.10
Annual LPG Consumption for heating water	Kg	630
Annual Thermal Energy Saving	kCal/kg	7247899
Annual Energy Saving	TOE	1
Annual expenditure due to LPG consumption for solar water heating @ 93.2/Kg	Rs.	58746
Installation Cost of 500 LPD Solar Water Heater	Rs.	70000
Annual financial saving due to reduction in LPG consumption	Rs. Lakh	0.59
Investment required	Rs. Lakh	0.70
Simple Payback Period	Year	1.19

9.7 Operation and Maintenance of CUTM

CUTM Electrical Maintenance team looks after the operation & maintenance of electric supply, ventilation & air conditioning, lighting system etc. of the entire building to ensure



proper work environment and comfort of its residents and officials. There are 4 nos. of Electricians working in CUTM. The work involves maintenance of lift, AC, motor, normal Fuse call Attending, Light replacement, Switching on/off of street light.

9.8 Energy Monitoring & Accounting System

Energy monitoring and targeting (M & T) is primarily a management technique that uses energy information as a basis to eliminate waste, reduce and control current level of energy use and improve the existing operating procedures. It builds on the principle “you can’t manage what you don’t measure”. It essentially combines the principles of energy use and statistics.

While, monitoring is essentially aimed at establishing the existing pattern of energy consumption, targeting is the identification of energy consumption level which is desirable as a management goal to work towards energy conservation.

Monitoring and Targeting is a management technique in which building utilities such as fuel, refrigeration, water, effluent, and electricity are managed as controllable resources in the same way that inventory, building occupancy, personnel and capital are managed. It involves a systematic, disciplined division of the facility into Energy Cost Centers. The utilities used in each centre are closely monitored. Once this information is available on a regular basis, targets can be set, variances can be spotted and interpreted, and remedial actions can be taken and implemented.

The Monitoring and Targeting programs have been so effective that they show typical reductions in annual energy costs in various industrial sectors between 5 and 20%.

The essential elements of M&T system are:

- Recording: Measuring and recording energy consumption.
- Analyzing: Correlating energy consumption to actual energy consumption
- Comparing: Comparing energy consumption to an appropriate standard or benchmark.
- Setting Targets: Setting targets to reduce or control energy consumption.
- Monitoring: Comparing energy consumption to the set target on a regular basis.
- Reporting: Reporting the results including any variances from the targets which have been set.
- Controlling:
- Implementing management measures to correct any variances, which may have occurred.

The energy used by any business varies with production processes, volumes and input. Determining the relationship of energy use to key performance indicators will allow the Building owner to determine:

- Whether the current energy is better or worse than before
- Trends in energy consumption that reflects seasonal, weekly, and other operational parameters



- How the future energy use is likely to vary Specific areas of wasted energy
- Comparison with other business with similar characteristics - This “benchmarking” process will provide valuable indications

Electrical Safety:

It is observed that the Single Line Diagram (SLD) of the entire electrical system is to be displayed at concerned places. This will help in identifying the fault easily and doing the maintenance job more effectively. The SLD should be reviewed once in year to put necessary changes.

At Panel rooms, the following points are suggested as per safety & electricity rules.

- Rubber mats should be placed on the floor around the PDB panels in each switch room.
- No panel door should be kept open in both sides.
- Proper bunching of cables should be ensured at each switch room. The cables should be clearly tagged at starting & ending points which would help for easy the identification of cables for fault finding & maintenance work.
- Danger plates should be displayed at concerned places.
- Proper naming of loads should be done on each panel.

Awareness and attitude of occupants toward energy efficiency:

It is suggested to create energy conservation awareness among the staff by observing Energy Conservation Day, encouraging & recognizing energy conservation efforts made by any individual or groups. A core committee on Energy Conservation, Electrical Safety, and Resource conservation may also be formed to review the related activities.

10.0 TECHNICAL SPECIFICATIONS FOR ENERGY EFFICIENT PRODUCT

1. Capacitor Bank

Standard parameter	Value/Feature
Total rating of capacitors	60 kVAr
Rated AC Voltage	440Volt
Frequency	50 HZ
No. of Phases	3 phase
Standard	IS 13340-1993
APFC relay	Microprocessor Based
Losses	< 0.2 W/kVAr



2. Lighting

Standard Parameter	Feature
Voltage	220 - 240 V
Shape	Bulb
Lifetime of lamp	15000 hour(s)
Lumen maintenance factor	0.7
Average life (at 2.7 hrs/day)	15.2 year(s)
Number of switch cycles	50000
Rated luminous flux	1400 lm
Rated lifetime	15000 hour(s)
Rated beam angle	150 degree
Light output	1400 lumen
Beam angle	150 degree
Colour temperature	6500 K
Light effect/finish	Cool Daylight
Colour rendering index (CRI)	80
Starting time	<0.5 s
Warm-up time to 60% light	Instant full light
Colour	Cool Daylight

3. Air Conditioner

Standard Parameter	Feature
Split AC (1.5 Ton)	
Cooling Capacity (Watt)	5280
Max Power Consumption (Watt)	1310
Preferable BEE Star Rating	5
Energy Efficiency Ratio (EER)	5.41W/W
Preferable Compressor Type	Rotary/reciprocating
Preferable Refrigerant Gas	R-32

4. 50 LPD Solar Water Heater

Standard Parameter	Feature
Specification	S.S 0.8mm THICKNESS INNER TANK 47mm X 1500mm ETC GLASS TUBES
System Capacity in LPD	50
Nos. of Tubes	8

**5. Energy Efficient Fan**

Model Name	E1-1200
Reversible Rotation	No
Remote	Yes
Blade Material	Aluminum
Leaf	3

Weight (kg)	4
Dimensions	120 x 140 cm
Down rod Height	30.48 cm
Span (mm/inch)	1200/48
Rated Voltage *	140 - 285
Rated Frequency	48 - 52
Input Power (typical)	28
Power Factor (typical)	0.95
Air Delivery	230

STAR RATING IN ROOM AIR CONDITIONERS*For Unitary Type Air Conditioner*

(From 1st January, 2021 to 31st December, 2023)

Indian Seasonal Energy Efficiency Ratio (kWh/kWh)		
Star level	Minimum	Maximum
1 Star	2.7	2.89
2 Star	2.9	3.09
3 Star	3.1	3.29
4 Star	3.3	3.49
5 Star	3.5	



For Split Type Air Conditioner

(From 1st January, 2021 to 31st December, 2023)

Indian Seasonal Energy Efficiency Ratio (kWh/kWh)		
Star level	Minimum	Maximum
1 Star	3.3	3.49
2 Star	3.5	3.79
3 Star	3.8	4.39
4 Star	4.4	4.99
5 Star	5.0”;	

STAR RATING IN DISTRIBUTION TRANSFORMERS

Permissible Limit for Dry Type Transformers

Rating kVA	Max. Losses at 50% loading W*	Max. Losses at 100% loading W*	Max. Losses at 50% loading W*	Max. Losses at 100% loading W*
	Up to 22 kV class		33 kV class	
100	940	2400	1120	2400
160	1290	3300	1420	3300
200	1500	3800	1750	4000
250	1700	4320	1970	4600
315	2000	5040	2400	5400
400	2380	6040	2900	6800
500	2800	7250	3300	7800
630	3340	8820	3950	9200
800	3880	10240	4650	11400
1000	4500	12000	5300	12800
1250	5190	13870	6250	14500
1600	6320	16800	7500	18000
2000	7500	20000	8880	21400
2500	9250	24750	10750	26500



Permissible Limit for Oil Type Transformers

Rating (kVA)	Impedance (%)	Max. Total Loss (W)					
		BEE 1 Star		BEE 3 Star		BEE 5 Star	
		50 % Load	100% Load	50 % Load	100% Load	50 % Load	100% Load
16	4.5	135	440	108	364	87	301
25	4.5	190	635	158	541	128	448
63	4.5	340	1,140	270	956	219	791
100	4.5	475	1,650	392	1,365	317	1,130
160	4.5	670	1,950	513	1,547	416	1,281
200	4.5	780	2,300	603	1,911	488	1,582
250	4.5	980	2,930	864	2,488	761	2,113
315	4.5	1,025	3,100	890	2,440	772	1,920
400	4.5	1,225	3,450	1,080	3,214	951	2,994
500	4.5	1,510	4,300	1,354	3,909	1,215	3,554
630	4.5	1,860	5,300	1,637	4,438	1,441	3,717
1,000	5.0	2,790	7,700	2,460	6,364	2,170	5,259
1,250	5.0	3,300	9,200	3,142	7,670	2,991	6,394
1,600	6.25	4,200	11,800	3,753	10,821	3,353	9,924
2,000	6.25	5,050	15,000	4,543	13,254	4,088	11,711
2,500	6.25	6,150	18,500	5,660	16,554	5,209	14,813

STAR RATING IN PUMP SETS

Star Rating	Performance Factor of the Pump Set
1 Star	≥ 1.00 & < 1.10
2 Star	≥ 1.10 & < 1.20
3 Star	≥ 1.20 & < 1.30
4 Star	≥ 1.30 & < 1.40
5 Star	≥ 1.40



11.0 MOU Format with EESL

MEMORANDUM OF UNDERSTANDING

This Memorandum of Understanding ("MOU"), effective from _____ is to confirm discussions between Energy Efficiency Services Ltd (EESL), a company organized under the laws of India; with its corporate office at 5th & 6th Floor, Core-3, SCOPE Complex, 7-Lodhi Road, New Delhi-110003 and Centurion University of Technology & Management (CUTM) Pitamahal, Rayagada, Odisha 765002.

Article 1: Purpose and Scope

This MOU confirms the preliminary discussions between CUTM and EESL regarding their intention to enter into transactions or services pertaining to implementation of energy efficiency measures at premises of CUTM.

A. Diagnostic Studies & Pilot Projects

- 1) Energy audits for entire campus to identify avenues for energy saving in electrical and thermal utilities
- 2) Water audits to identify areas/means to reduce specific water consumption
- 3) Lubricant and diesel Conservation Studies
- 4) Pilot studies on Cross-Cutting technologies

B. Implementation of Energy Efficiency Projects through innovative financial models

- 1) Installation/distribution of LED Lights and Energy Efficient appliances (Fans and / or Air Conditioners) across the facilities of CUTM.
- 2) Installation of energy efficient motors (IE3 type) in place of conventional motors
- 3) Installation of Smart Meters
- 4) Installation of Solar PV Power Projects

C. Capacity Building & Training

- 1) Technical training to campus executives on various topics pertaining to Energy Management, Maintenance Management, Water Management and Safety Engineering
- 2) Organizing suitable study tours and Guest Lectures on suitable topics
- 3) Creating cadre of energy professionals i.e. certified energy managers and auditors
- 4) Facilitating in Certification and Recognition: National Energy Conservation Award, Green Building etc.

EESL in consultation with CUTM shall execute the implementation of Energy Efficiency projects on ESCO Model (Energy Servicing Company). Under this activity, CUTM would provide the inventory list of their facilities / buildings and EESL would submit the Business and Financial proposal based on deemed savings principle leading to signing of Contract Agreements (s).



The activities are advisory services which EESL will provide with consultancy charges after mutual agreement between the Parties. EESL will submit proposals or annual work plans depending upon the requirement from CUTM.

Article 2: Non-Binding MOU for Future Cooperation

This MOU describes the general conditions and arrangements for further discussions between the parties and is non-obligatory. The exact terms and conditions of this future cooperation will be negotiated in due course and delineated in one or more separate and definitive agreements in the future, should circumstances warrant. Neither party shall be liable to the other for any claim, loss, cost, liability or investment opportunities arising out of directly or indirectly related to the other Party's decision to terminate this MOU, the other Party's performance under this MOU, or any other decision with respect to proceeding or not proceeding with the definitive agreement(s) or the Project(s). Further, each party acknowledges and agrees that the decision to enter into definitive agreement is the sole and absolute discretion of the other party.

Article 3: General Terms and Conditions

A) Term: This MOU shall remain in full force and effect for a period of thirty-six (36) months from the effective date, unless it is: (i) superseded by any or all of the definitive documents contemplated in Article 2 (or such other definitive documents as the parties may agree to enter into for their mutual benefit), or (ii) earlier terminated for convenience by the parties in writing by giving 30 (thirty) calendar days' notice.

B) Modification; Waiver; Severability; Assignment: No waiver of any right or remedy on one occasion by either party shall be deemed a waiver of such right or remedy on any other occasion, if any provision of this MOU is held invalid under any applicable law, such holding shall not affect the validity of remaining provisions and same shall continue in full force and effect. Neither party may assign this MOU, in whole or in part, without the prior written consent of both the non-assigning party.

C) Headings: Headings used in this MOU are for reference purposes only and shall not be used to modify the meaning of the terms and conditions of this MOU.

D) Entire Agreement: This MOU represents the entire understanding and MOU between the parties with respect to the subject matter hereof, and supersedes all prior and contemporaneous communications, representations or agreements, oral or written, regarding the subject matter hereof.

E) Counterparts: This MOU may be executed in two or more counterparts, each of which shall be deemed an original but all of which shall constitute the same MOU. This MOU and any document or schedule required hereby may be executed by facsimile signature that shall be considered legally binding for all purposes.

F) Confidentiality: In recognition of the confidential nature of this MOU and information developed or received hereunder Receiving Party shall not disclose or convey without the prior written consent of Disclosing Party any such technical information received from Disclosing Party or developed under this Agreement to any other party for the duration of the project and for a minimum period of ten (10) years from the date of project completion, termination or short closure. Receiving Party shall establish adequate procedures to prevent such transmittal of such technical information by its current employees.



The undertakings in Articles F shall not apply to the following:

- i. Information which is necessarily disclosed to third parties to enable the performance of work to be carried out in connection with this MOU, provided that the third party receiving the information enters into an agreement to keep the information confidential in accordance with this Article F;
- ii. Information which is ordered to be disclosed by a court of competent jurisdiction;
- iii. Information which is already in the public domain (except because of any breach of this undertaking);
- iv. Information which the party receiving the information can demonstrate from written records was already known to it at the time of receipt of such information from the party disclosing the information.

AGREED AND ACCEPTED:

Centurion University of Technology & Management, Rayagada

Energy Efficiency Services Limited

Name:
Designation:
Address:

Name:
Designation:
Address:
5th & 6th Floor, Core-3
SCOPE Complex, 7-Lodhi Road
New Delhi-110003

WITNESS



12.0 ENERGY MANAGEMENT POLICY

Energy management policy provides the foundation for setting performance goals and integrating energy management into an organization's culture. It is a well-known fact that a formal written energy policy acts both as: A public expression of an organization's commitment to energy management and working document to guide energy management practices and provides continuity.

It is the organization's best interest that support for energy management is expressed in a formal written declaration of commitment accompanied by a set of stated objectives, an action plan for achieving them and clear specifications of responsibilities.

The format of energy policy statement is various, but it usually includes the goal or objective of the organization and the more concrete targets in the field of Energy Management (or Energy Conservation). It often shows the major measures and time tables. The statement shall match the organization's mission statement or overall management strategy plan.

The guiding principle of the proposed energy conservation policy should include

- To endeavor for reduction in Specific Consumption of Energy is all forms and in all areas of operations.
- To ensure availability of information and necessary resources for achieving objectives and targets.
- To comply with all applicable legal, regulatory and other requirements related to energy use, consumption and efficiency.
- To espouse Energy Efficient Technology encompassing procurement of Energy Efficient Products and services and design for Energy Performance Improvement.
- To carry out Energy Audits and Energy Reviews at planned intervals to improve Energy performance.

Actual drafting / reviewing of energy policy will depend upon an organizations corporate culture and management style. We feel that the policy will get wider acceptance if all the concerned parties have been given the opportunity to contribute to the proposed amendment. All departmental representatives should be invited to make submission when the policy is reviewed. After the policy is reviewed, it should be approved by the Board and it should be formally adopted. Further it is recommended to form a energy conservation cell in CUTM in which faculty members from electrical department, utility managers, finance manager and senior management representative to be there. They should organize regular monthly meeting and awareness program in the campus. They should also explore possibilities for implementation of energy efficiency and renewable energy project.



Annexure:

1. Format of Energy Bill:

SUMMARY OF ENERGY BILL OF ----- FOR FINANCIAL YEAR -----																			
Month	Energy Consumed in kWh	Av. Load Factor	Av. Power Factor	MD in kW	MD in kVA	Energy Charge in Rs.	Demand Charge in Rs.	PF Penalty (+ve) / PF Incentive (-ve)	Rebate	CSC	TOD Incentive	Overdraw Penalty	Delay Payment Surcharge	Interest on Security	Meter Rent in Rs.	Electricity Duty	Current Monthly Bill in Rs.	Energy Charge in Rs./kWh	Unit cost in Rs. per kWh
Apr																			
May																			
Jun																			
Jul																			
Aug																			
Sep																			
Oct																			
Nov																			
Dec																			
Jan																			
Feb																			
Mar																			
Total / Av.																			
Monthly Average																			
Daily Average																			



2. Technical Specification of DG Set & Energy Data Sheet of DG:

Energy Data Sheet of -----kVA DG Set for FY -----			
Month	Diesel Consumption in kL	Total Energy Generated in DG Set in kWh	SEC in Liter/kWh
Apr			
May			
Jun			
Jul			
Aug			
Sep			
Oct			
Nov			
Dec			
Jan			
Feb			
Mar			
Total			



3. Technical data sheet of ----- Transformers & Transformer Performance Assessment:

Technical data sheet of ----- Transformers	
Particulars	TRF no.-----
Make	
Transformer rated in kVA	
Rated voltage ratio in kV	
Rated current ratio in Amp	
No. of phase	
Vector diagram	
Type of cooling	
Measured voltage at LT side in kV	
Measured current LT Side in Amp	
Measured Power Factor	

Transformer Performance Assessment	
Details	TRF no.-----
Transformer Rating in KVA	
Measured voltage at LT side in kV	
Measured current in LT Side Amp	
No Load Loss (kW)	
Full Load Loss of Transformer (kW)	
Measured load (kVA)	
% Loading on the Transformer (Measured kVA/ Rated kVA)	
Actual Losses of Transformer (kW)	
Operating Power Factor	



Total Actual Power Delivered by Transformer in kW	
Transformer Efficiency, %	
Transformer performance	

4. LUX Measurement

LUX Measurement		
Area	Measured LUX	Recommended LUX

5. Energy Management Training Program Log Sheet

Energy Management Training Program of CUTM, Paralakhemundi															
Sl. No.	Energy Committee Members	Designation	Ph. No.	April	May	June	July	August	September	October	November	December	January	February	March

**13.0 Vender Details of Projects**

Vender details for CUTM						
Sl. No	Vendor Name	Service	Address	Phone Number	Email	Website
1	Star Enterprises	Solar Water Heater	205A, Snehalata Apartment, Vivekananda Marg, Bhubaneswar-751002	9040310328/ 7008527362	starenterprisesbbsr@gmail.com	
2	Lavancha Renewable Energy Pvt.	Solar Water Heater	Ltd. Regus CBD, Level 9, East Wing, Raheja Towers, MG Road, Bengaluru – 560 001	99006 66885 / 7348907677	niranjan.patil@lavancha.in / info@lavancha.in	https://www.lavancha.in/
3	Sky shade Daylights Pvt Ltd	Light Pipe system	#401, Jyothi Flora, Plot no. 240, B-Block, Kavuri hills, Madhapur, Hyderabad-500081	91-40 4020 4022/33	marketing@skyshade.in	www.skyshade.in
4	Tanstate Global	Light Pipe system	Regulus, S No 1/10/2, B 801, Balewadi Near PMC School Pune 411045	7219700559	tanstateglobal@gmail.com / tsg@tanstateglobal.com	http://www.tanstateglobal.com
5	KRISHNA ENGINEERS & CONSULTANTS	Biogas Plant	Plot No: 4723, Laxmi Vihar, Lane-3, Sainik School, Bhubaneswar, Odisha, India-751005	09114160231, 09437256123	krishnaenergy@gmail.com / krishnaenergy2@gmail.com	www.krishnaenergy.com
6	Energy Efficiency Services Limited	AC Replacement	Ground Floor, House No. 409/B, Sahid Nagar, Bhubaneswar, Dist. Khordha Odisha – 751007.	9861486746	info@power-tech.group	



Investment Grade Energy Audit of CUTM, Rayagada

7	Energy Efficiency Services Limited	28W Super Energy Efficient Ceiling Fan	Ground Floor, House No. 409/B, Sahid Nagar, Bhubaneswar, Dist. Khordha Odisha - 751007.	9861486746	info@power-tech.group	
8	Solar Sack (A unit of Nemhans Solution Pvt. Ltd)	Solar Rooftop Project	N4/234,IRC Village, Nayapalli,Bhubaneswar	9238412384	quotation@solarsack.in	
9	UNIFY SOLAR	Solar Rooftop Project	DELHI	9212560106, 9667966755	unifysolar@gmail.com	http://www.unifysolar.in