



**Centurion
UNIVERSITY**

Shaping Lives... Empowering Communities...

www.cutm.ac.in

Centurion University of Technology and Management

(Established Vide Odisha Act 4 of 2010 & u/s 2 (f) of UGC Act, 1956)

To

Date: 3rd July, 2019

M/S Reliance Jio Infocomm Limited,
1st Floor, Fortune Tower, Chandrasekharpur,
Bhubaneswar, 751023

Subject

Purchase order for Internet Leased Line (ILL) service - 1000 Mbps

Kind attention

Prashant Tyagi

This has reference to your proposal and our subsequent discussions regarding the purchase of **1000Mbps** capacity ILL (Internet Leased line).

We are pleased to place the order for the same with following details

ILL Capacity	: <u>1000 Mbps</u>
IP's	: <u>16</u>
Connectivity	: <u>Fiber</u>
Installation address	: <u>CUTM, Centurion University of Technology & Management</u> <u>At: Alluri Nagar, Post: R. Sitapur, Via: Uppalada,</u> <u>Paralakhemundi</u> District: Gajapati, Odisha PIN-761 211
One Time charges	: <u>Rs. 5,000</u> (Taxes are extra on actuals)
Annual recurring charges	: <u>Rs. 28,00,000</u> (Taxes are extra on actuals)
Contract period	: <u>1 years</u>
Payment Terms	: <u>Quarterly Advance</u>
Delivery time	: <u>3 Month</u>
Billing address	: CUTM, Centurion University of Technology & Management At: Alluri Nagar, Post: R. Sitapur, Via: Uppalada, Paralakhemundi District: Gajapati, Odisha PIN-761 211

Other terms and conditions and service specifications are as per your proposal

Looking forward to fruitful relationship,

Yours sincerely,

(Signature & Stamp)

Deputy Registrar

Name : Prof. Sandipan Pine CUTM, Paralakhemundi
Gajapati

Date : 03/07/2019 Place : CUTM, Alluri Nagar, R. Sitapur

CUTM Campuses

Paralakhemundi: At- Village Alluri Nagar, PO - R. Sitapur, Via : Uppalada, Paralakhemundi - 761211
Dist- Gajapati, Odisha, India, Ph: +91-6815-222999, 222070, 222770, 223088
Fax : 222150 / 222976, E-mail : deansoet.pkd@cutm.ac.in & registrar@cutm.ac.in
Bhubaneswar: At- Ramachandrapur , PO- Jatni, Bhubaneswar, Dist. Khurda, Odisha, India
Ph: +91 674 2490088, 2492186, 2492495, 2490481, 2490482
Fax : +91 674 2490480, E-mail: principal@cgi.ac.in

Corporate office

HIG - 5, Phase-1 BDA Duplex, Pokhariput
Bhubaneswar - 751 020, Odisha, India,
Ph: +91 674 2352014, 2350667, Fax: +91 674 2351433
E-mail: rmanageradmin.cgi@gmail.com

Customer Acceptance Document

(I-OR-GRNI-ENT-0001)

1. Organization Name: Jagannath Inst For Tech & Mgmt
2. Site Address: Khata No 151/448, Aluri Nagar R. SitapurJitm Campus Gajapati, 761200, Parlakhemundi, Gajapati
3. Circuit id: ILL_9120052089_300635744595
4. ORN :- E00000006WJG
5. Services: Internet Leased Line (ILL)
6. Customer Contact Details:

Sr No	Name	email id	Contact Number
1	SANDIPAN PINE	SANDIPAN@CUTM-AC.IN	7978815760
2			8895308800
3			

7. Service details:

Sr No	Parameters	Details
1	Circuit id	ILL_9120052089_300635744595
2	Circuit Bandwidth (Mbps / Gbps)	1000Mbps
3	Media (Fiber / UBR / FTTx)	Fiber
4	WAN IP Address with subnet mask	136.232.105.128/30
5	LAN IP Address with subnet mask	115.240.99.48/29
6	Gateway IP Address	
7	Routing Protocol	
8	AS Number in case of BGP	
9	Port Type (Electrical / Optical)	Electrical
10	Customer facing Port Number	

8. Jio provided Inventory / Equipment details at site:

Sr No	Make & Model Number of Equipment	Serial Number	Quantity
1	UBR L2 SWITCH		01
2			
3			

9. Test Chart for Service parameter(s):

Sr No	Test Parameter	UoM	Committed	Observed
1	Latency	ms		7ms
1a	Mumbai to London	ms		

1b	Mumbai to New York	ms		
1c	Chennai to Los Angeles	ms		
1d	Chennai to Singapore	ms		
1e	Mumbai to Chennai	ms		
2	Packet Loss	%	0%	0%
3	Jitter (as applicable)	ms		
4	Bandwidth	Mbps / Gbps	1000 Mbps	
5	RFC 2544	RFC 2544 Report		

10. Last mile network connectivity diagram

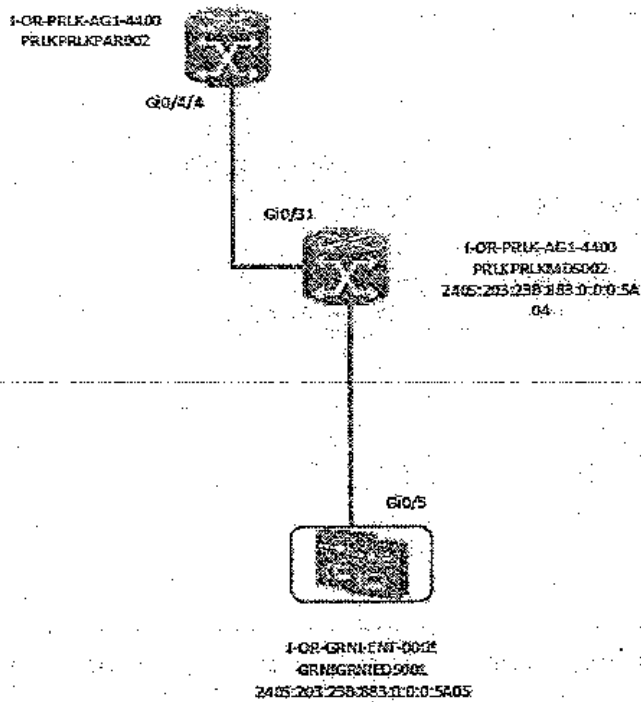

DNS :- 49.45.0.1

For Reliance Jio Infocomm Limited (RJIL)

Name: BISWA BIJAY BISWAL

Signature: B. Biswal

Date: 19/03/2020



Customer Acknowledgement

I hereby acknowledge that I have tested the said link and associated services bearing Circuit id # **ILL_9120052089_300635744595** and certify that the services are satisfactory and as per design / order.

Basis the above, I hereby authorize Reliance Jio Infocomm Limited (RJIL) to initiate services and billing effective date DD/MM/YYYY

Name: SANDEPAN PINE

Signature: Sandipan pine

Date: ~~24-02-2020~~ 19/03/2020

Company Seal



Customer Information (As per Jio Records)		
1	Name of Customer / Organization	Jagannath Inst For Tech &Mgmt
2	Logical Circuit ID's (if required Annexure can be used)	ILL_9120052089_300635744595
3	Date of Commissioning of Link (in case of up-gradation, mention date of initial commissioning and date of last up gradation)	
4	Service Type	ILL Bandwidth: 1000Mbps
	IP Address (in case of ILL)	Dynamic <input type="checkbox"/> Static <input checked="" type="checkbox"/> In case of Static mention Static IP allocated: LAN POOL :- 115.240.99.48/29 WAN POOL :- 136.232.105.128/30
5	Installation Address *The address should be the same as provided at the time of installation	Khata No 151/448,Aiuri Nagar R SitapurJitm Campus Gajapati,761200,Parlakhemundi,Gajapati
6	Account Manager Name and Contact Details	SANDIPAN PINE, MOB-7978815760 Sandiper@cutm.ac.in
7	Date of Inspection	19/03/2020
8	Type of Inspection	First <input checked="" type="checkbox"/> Periodic <input type="checkbox"/>
PHYSICAL INSPECTION OBSERVATIONS		
1	Contact Person Name	Name: ANIL KUMAR PATRO Designation: SYSTEM MAINTAINANCE INCHARGE
2	Contact Details	ANIL KUMAR PATRO, 9861853499 Email ID - ANIL.PATRO@CUTM.AC.IN
	Name:	
	Mobile Number:	
	Email id:	
3 (a)	OSP Registration Number & Date (if applicable)	OSP (Other Service Provide <input type="checkbox"/> Telemarkete <input type="checkbox"/> Othe <input type="checkbox"/>
3 (b)	ISP License Number and Date (if applicable)	
3 (c)	Telemarketer Registration Number and Date (if applicable)	
4	Whether the connection is used for Application Services like Telemedicine/Telebanking/Tele-Education/Tele-Trading/E-Commerce/Call Centre/Network Operating Centre/Vehicle tracking System/Long Range Alarm/Bill Payment Terminal etc.	Yes <input type="checkbox"/> No <input checked="" type="checkbox"/>

B. Biswal
19/03/2020

Signature and code of the verifying Person
of the verifying agency

(Authorized Person from Jio)



Declaration/Undertaking from applicant/Client

I/We hereby declare and confirm that

1. I/We are using the connection as per attached network diagram for bonafide usage and for the purpose declared by me/us at the time of subscribing to these connections and these connections are not interconnected with any PSTN, PLMN, GMPCS network.. I/We are not indulged in any unauthorized activities/usage or provision of any services which require prior licensing or permission from designated authorities.
2. I/We have intimated to the Licensor (Copy to respective TERM Cell) in a quarterly report the details of ISP nodes or points of presence with their locations and number of broadband/leased/dialup subscriber.(only in case of ISP customer)
3. I/We have given to the Licensor one month prior notice (Copy to respective term Cell) as required as per terms and condition of ISP License agreement in case new nodes to be installed.(only in case of ISP customer)

Sandipan pine

Signature of authorized person & Company Seal/Stamp

19/03/2020

Date

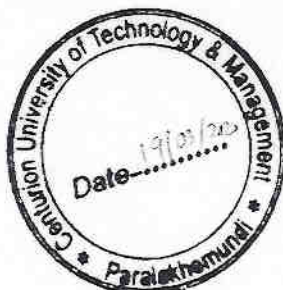

Note:

- I. Network Diagram should be collected from the customer or should be drawn by the verification agent as per the observations.
- II. In case of OSP customer, approved network diagram by TERM Cell should be collected.

Note :- Customer Internal network beyond handover server has not been shared by customer.

For Jio Use Only:

1	Name of Customer	Jagannath Inst For Tech &Mgmt
2	Circuit ID	ILL_9120052089_300635744595
3	Date of Inspection	
4	Network Diagram Verified & Updated	Yes <input checked="" type="checkbox"/> No <input type="checkbox"/>
5	Whether the installation address is Matching with Jio records?	Yes <input checked="" type="checkbox"/> No <input type="checkbox"/>
6		
7	Name of the verification agency (wherever applicable)	N/A
8	Name of executive carrying out Verification.	
9	Remarks/Any other observation found at site	N/A
10	Result of Verification	Positive <input checked="" type="checkbox"/> Negative <input type="checkbox"/>

Note:

- I. In case of any suspicion about the nature of the business carried out/observed, the same has to be brought to the knowledge of concerned Account Manager and CS team on immediate basis.
- II. Any Additional documents collected at the time of physical inspection must be handed over to the JC Onboarding team for records.

B. Biswal

19/03/2020

Signature of the verifying person
verifying agency

(Authorized Person form Jio)



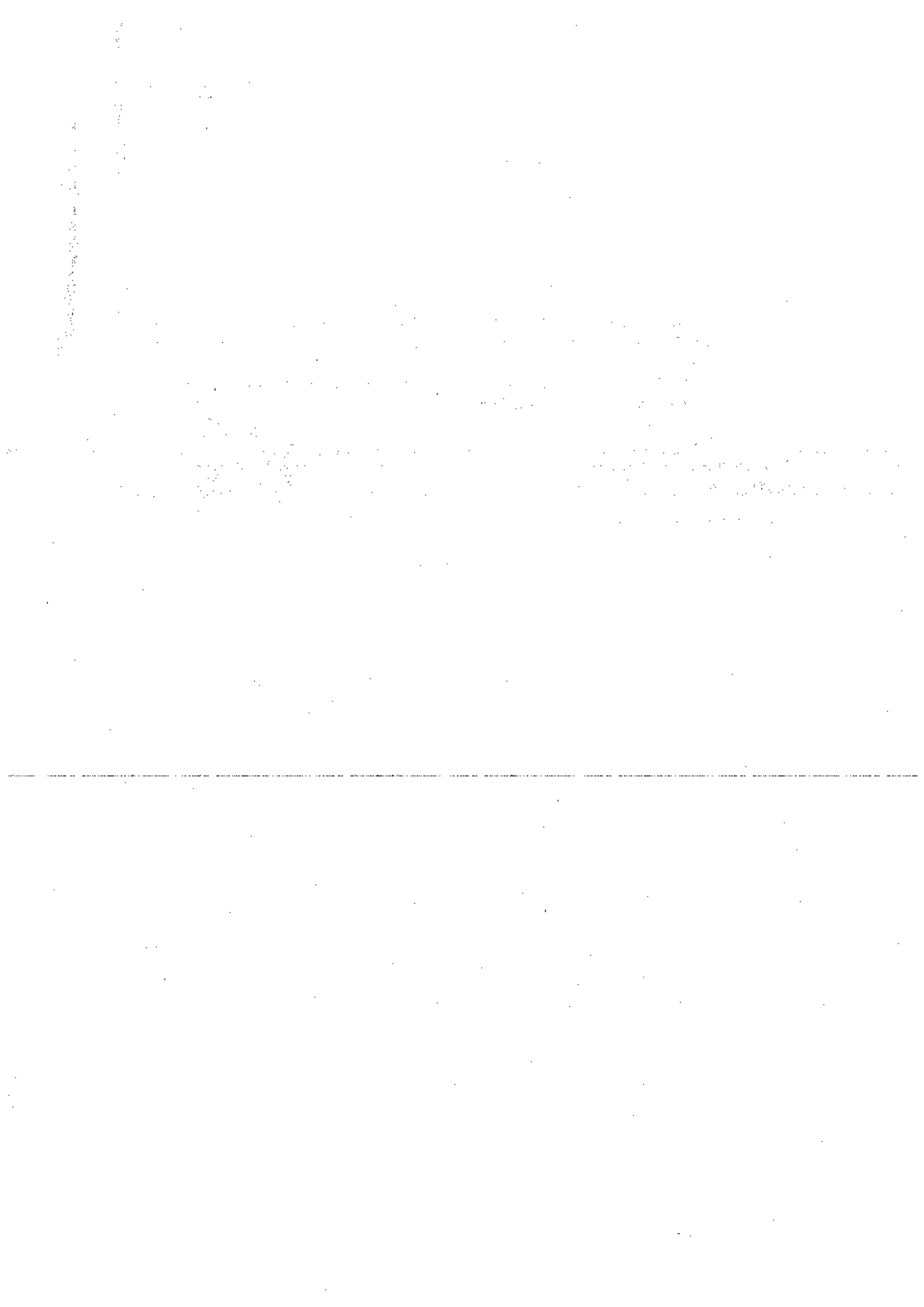



BHARAT SANCHAR NIGAM LIMITED

Office Of :
CGM "O/o GM Telecom District
Bhubaneswar" "CGMT ORISSA
Bhubaneswar"

Provisional Demand Note

Please pay the Provisional Demand Note amount, before 15-FEB-2011 for the circuit registered as per your request

DN No.: PDN/674#/000059/2010-11

DN Date: 25-Jan-2011

Billing Criteria: Yearly

Application Type: New Provision

BCA: Bhubaneswar

Application No.: A201101330882

Unique Service ID.: 201101330882

Customer's Name & Address

M/S. CENTURIAN UNIVERSITY OF TECHNOLOGY

RAMACHANDRAPUR, JATANI KHURDA, Bhubaneswar, Orissa, 111111, India

Circuit Type: DATA

Bandwidth Capacity: 1 GB

Duration: Permanent

MLLN A-End: No, MLLN B-End: No

Stand by: No

LLA : RAMACHANDRAPUR, JATANI KHURDA, Bhubaneswar, Orissa, 111111, India

LLB : MAIN TELEPHONE BHAWAN, UNIT-3, Bhubaneswar, Orissa, 751001, India

BandWidth Name: 1 GBPS

Last Mile A : OFC

Last Mile B : OFC

Details of Charges	Rate (Rs./Ps.)	Quantity	Amount (Rs./Ps.)
NMEICT SPECIAL PACKAGE	4,500,000.00	1	4,500,000.00
Additional Charge 1	900,000.00	1	900,000.00
Less : Discount1			4,500,000.00
Less : Discount2			461,000.00
Provisional Demand Note Amount before Tax			439,000.00
Service Tax @ 10%			43900.00
Education Cess @ 2 %			878.00
Secondary & Higher Education Cess @ 1 %			439.00
Net Amount Payable / Adjustable			484,217.00

RUPEES FOUR LAKH EIGHTY FOUR THOUSAND TWO HUNDRED AND SEVENTEEN ONLY.

- Remarks :
1. RS 900000/- ADDITIONAL CHARGES FOR PORT.
 2. RS 4500000/- DISCOUNT ON PORT CHARGES
 3. RS 461000/- ADDITIONAL CHARGES FOR PORT.

Income Tax PAN No.:

Disclaimer:

Service Tax Regn. No.:

3. If the circuit is cancelled before provisioned, advance rental for 3 months will be forfeited
4. This demand note is only a provisional subject to technical feasibility indicating provisional Chargeable Distance and MLLN Availability.

Copy To



PDN/674#/000059/2010-11

Commercial Officer,
Commercial Officer BSNL
BDE Commercial-III

O/o GM T D Bhubaneswar
GM T D, Bhubaneswar, GM T D, Bhubaneswar
Default-111111, Default, India.

45,00,000
@ 10.3% 4,63,500
Total 49,63,500/-
for 5 yrs.
One yr. 9,92,700/-
Less Paid 5,08,483
4,84,217/-

Approved

सभी सी बी एस शाखाओं पर देय PAYABLE AT ALL CBS BRANCHES

रिक्त/DATE 22/02/11

PAY TO THE ORDER OF AC Cash BSNL o/o GMID, BPSR

या धारक को OR BEARER

रुपये RUPEES Five lakh eighty four thousand अंश को
Five hundred Seven thousand only

₹.Rs. 484,217/-

--	--	--	--	--	--	--	--	--	--

ओरियन्टल बैंक ऑफ़ कॉमर्स
ORIENTAL BANK OF COMMERCE



For CSREM TRUST

M. C. Singh
Authorized Signatory For CSREM TRUST
Authorized Signatory

MPL 64951011000847

IFSC CODE: ORBC010043
BRANCH: MUMBAI 00 RUMI/RTS/SPR

⑈ 239348⑈ 000022000⑈

29

Received one Cheque
of Amount ₹ 484,217/-
on 29.01.2011.
29.01.2011
Kishor Kumar

JAGANNATH INSTITUTE FOR TECHNOLOGY AND MANAGEMENT TRUST

Approved by AICTE, Recognized by Govt. of Orissa and a Constituent College of C.U.T.M., Paralakhemundi, Odisha

To,
The Manager,
Reliance JIO,
Cuttack, Odisha

Date-12.09.2020

Subject: - Authorization for signing Reliance JIO related matters.

Dear Sir/Madam

We are hereby authorizing **Mr Rajesh Kumar Padhi** to represent, sign all the documents relating to Reliance JIO matters. For your reference signatures are attested below.

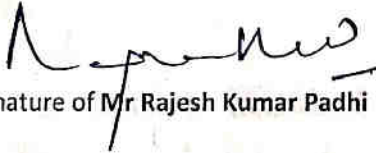

Signature of Mr Rajesh Kumar Padhi

Thanks & Regards

(Prof. D. N. Rao)
(Vice President)

JAGANNATH INSTITUTE FOR TECHNOLOGY AND MANAGEMENT TRUST

Approved by AICTE, Recognized by Govt. of Orissa and a Constituent College of C.U.T.M., Paralakhemundi, Odisha

Date: 12/09/2020

To

M/S Reliance JioInfocomm Limited,
Fortune Tower,
Bhubaneswar, Odisha - 751023

Subject: Purchase order for Internet Lease Line (ILL) Service- 10 Mbps

Kind attention

Mr. Amit Kumar Mohanty

This has reference to your proposal and our subsequent discussions regarding the purchase of Internet Lease Line

We are pleased to place the order for the same with following details

Bandwidth : 10 Mbps

No of IP's : 8 (Static Ip, Usable 6)

Installation address : Jagannath Inst. For Tech. & Mgmt.

At - Pitamahai, Dist - Rayagada

Odisha, 765002

One Time charges : Rs5,000/- + Taxes

Annual recurring Charges : Rs1,00,000/- (One Lakh Only) + Taxes

Contract Period : 1 years

Payment Terms : Quarterly Advance

Deliver : 4-6 Weeks

Taxes are extra on actuals

Billing address : Same as Installation

Other Terms & Conditions and service specifications are as per proposal agreed upon by both side

Looking forward to fruitful relationship,

Yours sincerely,



(Rajesh Kumar Padhi)
Authorised Signatory

Regional Director
JITM, +2 Sc. Res. College
RAYAGADA



Centurion
UNIVERSITY

PARALAKHEMUNDI CAMPUS

INTERNET BILL WITH BAND WIDTH



Paralakhemundi Campus: At - Village Alluri Nagar, P.O - R Sitapur, Via - Uppalada, Paralakhemundi - 761 211, Dist: Gajapati, Odisha, Phone: (06815) 222999

Bhubaneswar Campus: At - Ramachandrapur, P.O - Jatni, Bhubaneswar - 752050, Dist: Khurda, Odisha, Phone: (0674) 2492496

Corporate Office: At - HIG - 4, Jaydev Vihar, Opp. Pal Heights, Bhubaneswar - 751013, Dist: Khurda, Odisha, India.

Website: www.cutm.ac.in

centurion university of technology and management

Shaping Lives... Empowering Communities...



DIGITAL LIFE

Jagannath Inst For Tech & Mgmt
Na,Khata No 151/448,
Aluri Nagar R Sitapur Jitm Campus Gajapati,
Parlakhemundi,Gajapati,
Odisha-761200,India

Original for Recipient
Account Number : 900250055138
GST Bill Number : C21E222300023847
Document Number : 532500104639
Invoice Date : 01-OCT-2022
IRN Date : 01-OCT-2022
Due Date : 18-OCT-2022

Place of Supply: 21 Odisha

GST Registration Number: 21AAATJ3251E2ZA
Organisation PAN : AAATJ3251E
Invoice Reference Number : b86cf47c406c32b8e1471fec1ff558f453a0cb2dd1c3931223510185d63926d2

Your ILL Bill

Refer following pages for details of charges

Payment Received (₹)	TDS Deducted / Reversed (₹)	Previous Adjustment (₹)	Previous Balance (₹)	Current Charges (₹)	Total Dues (₹)
825,999.00	0.00	0.00	-1.62	825,998.82	825,997.20

	Amount(₹)
1 Periodic Charges	
Bandwidth Rental	699,999.00
CPE Rental	0.00
SLA	0.00
CoS Charges	0.00
Managed Services	0.00
Secondary Link	0.00
2 Other Periodic Charges	0.00
3 Other Charges	0.00
4 One Time Charges	0.00
5 Total Value of Charges	0.00
6 Current Month Discount / Credit / Debit	0.00
7 Current Taxable Charges	699,999.00
8 Taxes	
CGST (9%)	62,999.91
SGST (9%)	62,999.91
9 Bill Discount including Tax	0.00
10 Security Deposit Charged	0.00
11 Security Deposit Returned	0.00
12 Waiver	0.00
Current Month Charges (7+8+9+10+11+12)	825,998.82

Payment Options

JioAutoPay

JioPay

Register with JioPay and get uninterrupted services.*

e-NACH (Debit Card)
To set e-NACH mandate on your bank account visit www.jio.com/business/

Standing Instructions (Credit Card)
Set JioAutoPay on your Credit Card. To register visit www.jio.com/business/ and click on Register for autopay of invoice by credit card.

*Details under Important Information JioPay

JioDigiPay

Selfcare Portal
Pay bills using credit/debit card/netbanking/ e-wallets/UPI on www.jio.com/business/

NEFT/RTGS
You can do NEFT/RTGS payments/transfers by using Virtual A/C Code RJIO900250055138, IFSC Code ICIC0000104



GSTIN: 21AABCI6363G1ZV PAN: AABCI6363G

Registered Office: Reliance Jio Infocomm Limited
Office-101, Saffron, Nr.Centre Point, Panchwati 5 Rasta,
Ambawadi, Ahmedabad-380006, Gujarat, India
CIN: U72900GJ2007PLC105869

State Office: Reliance Jio Infocomm Limited
Fortune Tower, 4th Floor Wing - C/2
Gangadhar Meher Marg, Chandrasekharpur,
Bhubaneswar 751023 Odisha

Gst Registered Office: Company
Khordha
C/o Ril-1st Floor Wing A/b Fortune Tower
Chandrasekharpur
Pincode: 751023 Bhubaneswar



Terms and Conditions

Tariff & Plans

- There will be no increase in any tariff item the agreed contract Period. Thereafter, Reliance Jio Infocomm Limited reserves the right to revise the terms & conditions applicable to tariff plans.
- RJIL reserves the right to vary the penal charge rates periodically, as well as take recourse to any other action available and considered appropriate, subject to TRAI regulations.
- No charge will be levied for any service without your explicit consent.
- For periodic charges, the calculation has been done as follows: Annual Rate/12* No. of Months.
- For Fractional months in a quarterly bill cycle, the calculation has been done as follows: (Annual Rate/4)* (Days of Service in Quarter/Total No. of days in Quarter).

Complaints & Service Requests

Visit www.jio.com, login with your Jio ID and password; click on "Service Request" option under Profile menu to raise a complaint. To track the status of your existing complaint, use your unique Service Request number. You can also call 198 (toll-free) from your Jio number or 1800 889 9444 from other networks to register your service request / complaint.

JioPay

- JioAutoPay
 - JioAutoPay debit will be on 22nd day following the date of bill.
 - Click to view the process www.jio.com/enterprise/autopay/

Service Accounting Codes (SAC)

SAC Code : Services	SAC Code : Services
998412 : Fixed Line Charges	998431 : Digital VAS Charges
998413 : Mobile Charges	998432 : Online Music Charges
998419 : VAS Charges	998433 : Online Video Charges
998422 : Data Charges	998439 : Online Content Charges
998414 : ILL	

Appellate Authority

In case you are unsatisfied with the response on a complaint, you can contact the regional appellate authority with your complaint docket number.

Email: appellate.ori@jio.com, Telephone number: 1800-889-3999, Fax: 1800-889-1211

Address: Reliance Jio Infocomm Limited, Fortune Tower, 1st Floor,

Wing A & B, Gangadhar Meher Marg, Chandrasekharpur

Bhubaneswar 751023 Odisha

(Working hours: Mon-Fri, 10:30 am to 6:00 pm)

Other Information

- The invoice will be deemed accepted as per the Master Service Agreement or Terms and Conditions signed.
- Reliance Jio Infocomm Limited reserves the right to change, from time to time, the terms and conditions of the contract by giving notice of the change.
- In the event of non-payment, part payment or late payment of the outstanding amount by the due date, or in the case of bounced cheques, Reliance Jio Infocomm Limited reserves the right to disconnect services. The customer shall continue to be liable for the charges during the period of suspension.
- In case of permanent disconnection, your security deposit will be refunded within 60 days of disconnection, failing which you shall be paid interest @10% p.a. following adjustment of dues.
- We request you to log disconnection request through online portal. Please login to www.jio.com/enterprise with your login id and password and click on New Service Request. Alternatively, you may also log disconnection at enterpriseservices@jio.com. Upon receipt of mail, a Service Request no. will be provided to you within 48 Hrs. Please note that In absence of SR number, no credit adjustments shall be made for the delay in disconnection and the customer shall be liable to pay for the charges.
- Goods and Service Tax(GST)and other indirect taxes, as may be applicable will be charged and shown separately over and above the billed amount. Further, any increase/addition/ introduction in taxes and/or levy of any taxes, levies, duties or any other statutory charges etc.,(present/future) shall be charged to the Customer without any notice and shall at all-time be deemed to be payable.
- E-Bills will be sent to the Customer to his e-mail address as mentioned in EAF. For any change in e-mail address, Customer shall intimate Enterprise customer care about new email address at least 15 days prior to the commencement of the next billing cycle. Customer is responsible to pay his bills by the prescribed date. It is incumbent on the Customer to enquire his/her balance and settle the same even in case of non-receipt of monthly bill for any reason whatsoever.
- The payment shall be made in favour of RJIO900250055138.
- RJIL reserve it right to reserve or notify payment institution as part of terms and conditions of invoices or bills whenever applicable.
- No cheque payment will be accepted against wireline services.
- TDS Certificate to be submitted within 30 days of filing statement of deduction of tax as per the provisions of Income-tax Act, 1961 read with Income-tax Rules, 1962. Non-adherence will lead to the reversal of the TDS amount posted, leading to service restriction in case outstanding is not cleared.

6 Months Balance

Sr. No.	Bill Number	Bill Date	Charges (₹)	Adjustments (₹)	Amount Paid (₹)	TDS Deducted (₹)	Balance Amount (₹)
1	551000097964	2022-07-01	825,998.82	0.00	825,998.82	0.00	0.00
2	521500089748	2022-04-01	825,998.82	0.00	825,998.82	0.00	0.00
3	517000105997	2022-01-01	825,998.82	0.00	825,998.82	0.00	0.00
4	536000102404	2021-10-01	825,998.82	0.00	825,998.82	0.00	0.00
5	524000098477	2021-07-01	825,998.82	0.00	825,998.82	0.00	0.00
6	529500053457	2021-04-01	825,998.82	0.00	825,998.82	0.00	0.00
Total							0.00

Payments Received

Sr. No.	Bill Number	Payment Date	Transaction Mode	Balance Amount(₹)
1		2022-07-14	RTGS	825,999.00
Total				825,999.00

Reach Us



Taxes

Sr. No.	Description	Charges	CGST	SGST	Amount (₹)
1	This month charges	699,999.00	62,999.91	62,999.91	125,999.82



DIGITAL LIFE

Jagannath Inst For Tech & Mgmt
Na,Khata No 151/448,
Aluri Nagar R Sitapur Jitm Campus Gajapati,
Parlakhemundi,Gajapati,
Odisha-761200,India

Original for Recipient
Account Number : 900250055138
GST Bill Number : C21E212200025958
Document Number : 517000105997
Invoice Date : 01-JAN-2022
IRN Date : 02-JAN-2022
Due Date : 18-JAN-2022

Place of Supply: 21 Odisha

GST Registration Number: 21AAATJ3251E2ZA
Organisation PAN : AAATJ3251E
Invoice Reference Number : c814268d09432dee12f16155ea3f80164be1fdd5a58bf0c13527e5c5224d28e1

Your ILL Bill

Refer following pages for details of charges

Payment Received (₹)	TDS Deducted / Reversed (₹)	Previous Adjustment (₹)	Previous Balance (₹)	Current Charges (₹)	Total Dues (₹)
825,999.00	0.00	0.00	-1.08	825,998.82	825,997.74

	Amount(₹)
1 Periodic Charges	
Bandwidth Rental	699,999.00
CPE Rental	0.00
SLA	0.00
CoS Charges	0.00
Managed Services	0.00
Secondary Link	0.00
2 Other Periodic Charges	0.00
3 Other Charges	0.00
4 One Time Charges	0.00
5 Total Value of Charges	0.00
6 Current Month Discount / Credit / Debit	0.00
7 Current Taxable Charges	699,999.00
8 Taxes	
CGST (9%)	62,999.91
SGST (9%)	62,999.91
9 Bill Discount including Tax	0.00
10 Security Deposit Charged	0.00
11 Security Deposit Returned	0.00
12 Waiver	0.00
Current Month Charges (7+8+9+10+11+12)	825,998.82

Payment Options

JioAutoPay

Register with JioPay and get uninterrupted services.*

e-NACH (Debit Card)
To set e-NACH mandate on your bank account visit www.jio.com/business/

Standing Instructions (Credit Card)
Set JioAutoPay on your Credit Card. To register visit www.jio.com/business/ and click on Register for autopay of invoice by credit card.

*Details under Important Information JioPay

JioDigiPay

Selfcare Portal
Pay bills using credit/debit card/netbanking/ e-wallets/UPI on www.jio.com/business/

NEFT/RTGS
You can do NEFT/RTGS payments/transfers by using Virtual A/C Code RJIO900250055138, IFSC Code ICIC0000104



GSTIN: 21AABC16363G1ZV PAN: AABC16363G

Registered Office: Reliance Jio Infocomm Limited
Office-101, Saffron, Nr.Centre Point, Panchwati 5 Rasta,
Ambawadi, Ahmedabad-380006, Gujarat, India
CIN: U72900GJ2007PLC105869

State Office: Reliance Jio Infocomm Limited
Fortune Tower, 4th Floor Wing - C/2
Gangadhar Meher Marg, Chandrasekharpur,
Bhubaneswar 751023 Odisha

Gst Registered Office: Company
Khordha
C/o Ril-1st Floor Wing A/b Fortune Tower
Chandrasekharpur
Pincode: 751023 Bhubaneswar



Terms and Conditions

Tariff & Plans

- There will be no increase in any tariff item the agreed contract Period. Thereafter, Reliance Jio Infocomm Limited reserves the right to revise the terms & conditions applicable to tariff plans.
- RJIL reserves the right to vary the penal charge rates periodically, as well as take recourse to any other action available and considered appropriate, subject to TRAI regulations.
- No charge will be levied for any service without your explicit consent.
- For periodic charges, the calculation has been done as follows: Annual Rate/12* No. of Months.
- For Fractional months in a quarterly bill cycle, the calculation has been done as follows: (Annual Rate/4)* (Days of Service in Quarter/Total No. of days in Quarter).

Complaints & Service Requests

Visit www.jio.com, login with your Jio ID and password; click on "Service Request" option under Profile menu to raise a complaint. To track the status of your existing complaint, use your unique Service Request number. You can also call 198 (toll-free) from your Jio number or 1800 889 9444 from other networks to register your service request / complaint.

JioPay

- JioAutoPay
 - JioAutoPay debit will be on 22nd day following the date of bill.
 - Click to view the process www.jio.com/enterprise/autopay/

Service Accounting Codes (SAC)

SAC Code : Services	SAC Code : Services
998412 : Fixed Line Charges	998431 : Digital VAS Charges
998413 : Mobile Charges	998432 : Online Music Charges
998419 : VAS Charges	998433 : Online Video Charges
998422 : Data Charges	998439 : Online Content Charges
998414 : ILL	

Appellate Authority

In case you are unsatisfied with the response on a complaint, you can contact the regional appellate authority with your complaint docket number.

Email: appellate.ori@jio.com, Telephone number: 1800-889-3999, Fax: 1800-889-1211
 Address: Reliance Jio Infocomm Limited, Fortune Tower, 1st Floor,
 Wing A & B, Gangadhar Meher Marg, Chandrasekharpur
 Bhubaneswar 751023 Odisha
 (Working hours: Mon-Fri, 10:30 am to 6:00 pm)

Other Information

- The invoice will be deemed accepted as per the Master Service Agreement or Terms and Conditions signed.
- Reliance Jio Infocomm Limited reserves the right to change, from time to time, the terms and conditions of the contract by giving notice of the change.
- In the event of non-payment, part payment or late payment of the outstanding amount by the due date, or in the case of bounced cheques, Reliance Jio Infocomm Limited reserves the right to disconnect services. The customer shall continue to be liable for the charges during the period of suspension.
- In case of permanent disconnection, your security deposit will be refunded within 60 days of disconnection, failing which you shall be paid interest @10% p.a, following adjustment of dues.
- We request you to log disconnection request through online portal. Please login to www.jio.com/enterprise with your login id and password and click on New Service Request. Alternatively, you may also log disconnection at enterpriseservices@jio.com. Upon receipt of mail, a Service Request no. will be provided to you within 48 Hrs. Please note that In absence of SR number, no credit adjustments shall be made for the delay in disconnection and the customer shall be liable to pay for the charges.
- Goods and Service Tax(GST)and other indirect taxes, as may be applicable will be charged and shown separately over and above the billed amount. Further, any increase/addition/ introduction in taxes and/or levy of any taxes, levies, duties or any other statutory charges etc.,(present/future) shall be charged to the Customer without any notice and shall at all-time be deemed to be payable.
- E-Bills will be sent to the Customer to his e-mail address as mentioned in EAF. For any change in e-mail address, Customer shall intimate Enterprise customer care about new email address at least 15 days prior to the commencement of the next billing cycle. Customer is responsible to pay his bills by the prescribed date. It is incumbent on the Customer to enquire his/her balance and settle the same even in case of non-receipt of monthly bill for any reason whatsoever.
- The payment shall be made in favour of RJIO900250055138.
- RJIL reserve it right to reserve or notify payment institution as part of terms and conditions of invoices or bills whenever applicable.
- No cheque payment will be accepted against wireline services.

6 Months Balance

Sr. No.	Bill Number	Bill Date	Charges ()	Adjustments ()	Amount Paid ()	TDS Deducted ()	Balance Amount ()
1	536000102404	2021-10-01	825,998.82	0.00	825,998.82	0.00	0.00
2	524000098477	2021-07-01	825,998.82	0.00	825,998.82	0.00	0.00
3	529500053457	2021-04-01	825,998.82	0.00	825,998.82	0.00	0.00
4	535000072108	2021-01-01	825,998.82	0.00	825,998.82	0.00	0.00
5	529000081691	2020-10-01	825,998.82	0.00	825,998.82	0.00	0.00
6	518500041216	2020-07-01	825,998.82	0.00	825,998.82	0.00	0.00
Total							0.00

Payments Received

Sr. No.	Bill Number	Payment Date	Transaction Mode	Balance Amount()
1		2021-10-21	RTGS	825,999.00
Total				825,999.00

Reach Us



Taxes

Sr. No.	Description	Charges	CGST	SGST	Amount (`)
1	This month charges	699,999.00	62,999.91	62,999.91	125,999.82



Product: ILL

Periodic Charges for the Billing Period - Existing Circuit

Per Site Recurring Charges for the Period - 01-Jan-2022 to 31-Mar-2022

Sr. No.	No of Sites	Bandwidth	Bandwidth	CPE	SLA	CoS	Managed Service	Secondary Link	Amount ()
1	1	1000 Mbps	699,999.00	0.00	0.00	0.00	0.00	0.00	699,999.00
Sub Total	1		699,999.00	0.00	0.00	0.00	0.00	0.00	699,999.00

Periodic Charges for the Billing Period - All Circuit

Sr. No.	No of Sites	Bandwidth	Bandwidth	CPE	SLA	CoS	Managed Service	Secondary Link	Amount ()
1	1	1000 Mbps	699,999.00	0.00	0.00	0.00	0.00	0.00	699,999.00
Per Site Recurring Charges per Annum									
Total	1		699,999.00	0.00	0.00	0.00	0.00	0.00	699,999.00
1	1	1000 Mbps	2799996.00	0.00	0.00	0.00	0.00	0.00	2,799,996.00
Total									2,799,996.00



DIGITAL LIFE

Jagannath Inst For Tech & Mgmt
Na,Khata No 151/448,
Aluri Nagar R Sitapur Jitm Campus Gajapati,
Parlakhemundi,Gajapati,
Odisha-761200,India

Original for Recipient
Account Number : 900250055138
GST Bill Number : C21E222300000171
Document Number : 521500089748
Invoice Date : 01-APR-2022
IRN Date : 03-APR-2022
Due Date : 18-APR-2022

Place of Supply: 21 Odisha

GST Registration Number: 21AAATJ3251E2ZA
Organisation PAN : AAATJ3251E
Invoice Reference Number : 8239212f50a059f7c1afbc7e03ad2ae53e80864c24b0e24baa49c51b76f28655

Your ILL Bill

Refer following pages for details of charges

Payment Received (₹)	TDS Deducted / Reversed (₹)	Previous Adjustment (₹)	Previous Balance (₹)	Current Charges (₹)	Total Dues (₹)
825,999.00	0.00	0.00	-1.26	825,998.82	825,997.56

	Amount(₹)
1 Periodic Charges	
Bandwidth Rental	699,999.00
CPE Rental	0.00
SLA	0.00
CoS Charges	0.00
Managed Services	0.00
Secondary Link	0.00
2 Other Periodic Charges	0.00
3 Other Charges	0.00
4 One Time Charges	0.00
5 Total Value of Charges	0.00
6 Current Month Discount / Credit / Debit	0.00
7 Current Taxable Charges	699,999.00
8 Taxes	
CGST (9%)	62,999.91
SGST (9%)	62,999.91
9 Bill Discount including Tax	0.00
10 Security Deposit Charged	0.00
11 Security Deposit Returned	0.00
12 Waiver	0.00
Current Month Charges (7+8+9+10+11+12)	825,998.82

Payment Options

JioAutoPay

JioPay

Register with JioPay and get uninterrupted services.*

e-NACH (Debit Card)
To set e-NACH mandate on your bank account visit www.jio.com/business/

Standing Instructions (Credit Card)
Set JioAutoPay on your Credit Card. To register visit www.jio.com/business/ and click on Register for autopay of invoice by credit card.

*Details under Important Information JioPay

JioDigiPay

Selfcare Portal
Pay bills using credit/debit card/netbanking/ e-wallets/UPI on www.jio.com/business/

NEFT/RTGS
You can do NEFT/RTGS payments/transfers by using Virtual A/C Code RJIO900250055138, IFSC Code ICIC0000104



GSTIN: 21AABCI6363G1ZV PAN: AABCI6363G

Registered Office: Reliance Jio Infocomm Limited
Office-101, Saffron, Nr.Centre Point, Panchwati 5 Rasta,
Ambawadi, Ahmedabad-380006, Gujarat, India
CIN: U72900GJ2007PLC105869

State Office: Reliance Jio Infocomm Limited
Fortune Tower, 4th Floor Wing - C/2
Gangadhar Meher Marg, Chandrasekharpur,
Bhubaneswar 751023 Odisha

Gst Registered Office: Company
Khordha
C/o Ril-1st Floor Wing A/b Fortune Tower
Chandrasekharpur
Pincode: 751023 Bhubaneswar



Terms and Conditions

Tariff & Plans

- There will be no increase in any tariff item the agreed contract Period. Thereafter, Reliance Jio Infocomm Limited reserves the right to revise the terms & conditions applicable to tariff plans.
- RJIL reserves the right to vary the penal charge rates periodically, as well as take recourse to any other action available and considered appropriate, subject to TRAI regulations.
- No charge will be levied for any service without your explicit consent.
- For periodic charges, the calculation has been done as follows: Annual Rate/12* No. of Months.
- For Fractional months in a quarterly bill cycle, the calculation has been done as follows: (Annual Rate/4)* (Days of Service in Quarter/Total No. of days in Quarter).

Complaints & Service Requests

Visit www.jio.com, login with your Jio ID and password; click on "Service Request" option under Profile menu to raise a complaint. To track the status of your existing complaint, use your unique Service Request number. You can also call 198 (toll-free) from your Jio number or 1800 889 9444 from other networks to register your service request / complaint.

JioPay

- JioAutoPay
 - JioAutoPay debit will be on 22nd day following the date of bill.
 - Click to view the process www.jio.com/enterprise/autopay/

Service Accounting Codes (SAC)

SAC Code : Services	SAC Code : Services
998412 : Fixed Line Charges	998431 : Digital VAS Charges
998413 : Mobile Charges	998432 : Online Music Charges
998419 : VAS Charges	998433 : Online Video Charges
998422 : Data Charges	998439 : Online Content Charges
998414 : ILL	

Appellate Authority

In case you are unsatisfied with the response on a complaint, you can contact the regional appellate authority with your complaint docket number.

Email: appellate.ori@jio.com, Telephone number: 1800-889-3999, Fax: 1800-889-1211

Address: Reliance Jio Infocomm Limited, Fortune Tower, 1st Floor,

Wing A & B, Gangadhar Meher Marg, Chandrasekharpur

Bhubaneswar 751023 Odisha

(Working hours: Mon-Fri, 10:30 am to 6:00 pm)

Other Information

- The invoice will be deemed accepted as per the Master Service Agreement or Terms and Conditions signed.
- Reliance Jio Infocomm Limited reserves the right to change, from time to time, the terms and conditions of the contract by giving notice of the change.
- In the event of non-payment, part payment or late payment of the outstanding amount by the due date, or in the case of bounced cheques, Reliance Jio Infocomm Limited reserves the right to disconnect services. The customer shall continue to be liable for the charges during the period of suspension.
- In case of permanent disconnection, your security deposit will be refunded within 60 days of disconnection, failing which you shall be paid interest @10% p.a. following adjustment of dues.
- We request you to log disconnection request through online portal. Please login to www.jio.com/enterprise with your login id and password and click on New Service Request. Alternatively, you may also log disconnection at enterpriseservices@jio.com. Upon receipt of mail, a Service Request no. will be provided to you within 48 Hrs. Please note that In absence of SR number, no credit adjustments shall be made for the delay in disconnection and the customer shall be liable to pay for the charges.
- Goods and Service Tax(GST)and other indirect taxes, as may be applicable will be charged and shown separately over and above the billed amount. Further, any increase/addition/introduction in taxes and/or levy of any taxes, levies, duties or any other statutory charges etc.,(present/future) shall be charged to the Customer without any notice and shall at all-time be deemed to be payable.
- E-Bills will be sent to the Customer to his e-mail address as mentioned in EAF. For any change in e-mail address, Customer shall intimate Enterprise customer care about new email address at least 15 days prior to the commencement of the next billing cycle. Customer is responsible to pay his bills by the prescribed date. It is incumbent on the Customer to enquire his/her balance and settle the same even in case of non-receipt of monthly bill for any reason whatsoever.
- The payment shall be made in favour of RJIO900250055138.
- RJIL reserve it right to reserve or notify payment institution as part of terms and conditions of invoices or bills whenever applicable.
- No cheque payment will be accepted against wireline services.

6 Months Balance

Sr. No.	Bill Number	Bill Date	Charges ()	Adjustments ()	Amount Paid ()	TDS Deducted ()	Balance Amount ()
1	517000105997	2022-01-01	825,998.82	0.00	825,998.82	0.00	0.00
2	536000102404	2021-10-01	825,998.82	0.00	825,998.82	0.00	0.00
3	524000098477	2021-07-01	825,998.82	0.00	825,998.82	0.00	0.00
4	529500053457	2021-04-01	825,998.82	0.00	825,998.82	0.00	0.00
5	535000072108	2021-01-01	825,998.82	0.00	825,998.82	0.00	0.00
6	529000081691	2020-10-01	825,998.82	0.00	825,998.82	0.00	0.00
Total							0.00

Payments Received

Sr. No.	Bill Number	Payment Date	Transaction Mode	Balance Amount()
1		2022-01-18	RTGS	825,999.00
Total				825,999.00

Reach Us



Taxes

Sr. No.	Description	Charges	CGST	SGST	Amount (`)
1	This month charges	699,999.00	62,999.91	62,999.91	125,999.82



DIGITAL LIFE

Jagannath Inst For Tech & Mgmt
Na,Khata No 151/448,
Aluri Nagar R Sitapur Jitm Campus Gajapati,
Parlakhemundi,Gajapati,
Odisha-761200,India

Original for Recipient
Account Number : 900250055138
GST Bill Number : C21E222300011108
Document Number : 551000097964
Invoice Date : 01-JUL-2022
IRN Date : 01-JUL-2022
Due Date : 18-JUL-2022

Place of Supply: 21 Odisha

GST Registration Number: 21AAATJ3251E2ZA
Organisation PAN : AAATJ3251E
Invoice Reference Number : 3636fce089c80859c482f01402d75cc6a4a50ce117db9b103dcd91c8343ff8ec

Your ILL Bill

Refer following pages for details of charges

Payment Received (₹)	TDS Deducted / Reversed (₹)	Previous Adjustment (₹)	Previous Balance (₹)	Current Charges (₹)	Total Dues (₹)
825,999.00	0.00	0.00	-1.44	825,998.82	825,997.38

	Amount(₹)
1 Periodic Charges	
Bandwidth Rental	699,999.00
CPE Rental	0.00
SLA	0.00
CoS Charges	0.00
Managed Services	0.00
Secondary Link	0.00
2 Other Periodic Charges	0.00
3 Other Charges	0.00
4 One Time Charges	0.00
5 Total Value of Charges	0.00
6 Current Month Discount / Credit / Debit	0.00
7 Current Taxable Charges	699,999.00
8 Taxes	
CGST (9%)	62,999.91
SGST (9%)	62,999.91
9 Bill Discount including Tax	0.00
10 Security Deposit Charged	0.00
11 Security Deposit Returned	0.00
12 Waiver	0.00
Current Month Charges (7+8+9+10+11+12)	825,998.82

Payment Options

JioAutoPay

JioPay

Register with JioPay and get uninterrupted services.*

e-NACH (Debit Card)
To set e-NACH mandate on your bank account visit www.jio.com/business/

Standing Instructions (Credit Card)
Set JioAutoPay on your Credit Card. To register visit www.jio.com/business/ and click on Register for autopay of invoice by credit card.

*Details under Important Information JioPay

JioDigiPay

Selfcare Portal
Pay bills using credit/debit card/netbanking/ e-wallets/UPI on www.jio.com/business/

NEFT/RTGS
You can do NEFT/RTGS payments/transfers by using Virtual A/C Code RJIO900250055138, IFSC Code ICIC0000104



GSTIN: 21AABCI6363G1ZV PAN: AABCI6363G

Registered Office: Reliance Jio Infocomm Limited
Office-101, Saffron, Nr.Centre Point, Panchwati 5 Rasta,
Ambawadi, Ahmedabad-380006, Gujarat, India
CIN: U72900GJ2007PLC105869

State Office: Reliance Jio Infocomm Limited
Fortune Tower, 4th Floor Wing - C/2
Gangadhar Meher Marg, Chandrasekharpur,
Bhubaneswar 751023 Odisha

Gst Registered Office: Company
Khordha
C/o Ril-1st Floor Wing A/b Fortune Tower
Chandrasekharpur
Pincode: 751023 Bhubaneswar



Terms and Conditions

Tariff & Plans

- There will be no increase in any tariff item the agreed contract Period. Thereafter, Reliance Jio Infocomm Limited reserves the right to revise the terms & conditions applicable to tariff plans.
- RJIL reserves the right to vary the penal charge rates periodically, as well as take recourse to any other action available and considered appropriate, subject to TRAI regulations.
- No charge will be levied for any service without your explicit consent.
- For periodic charges, the calculation has been done as follows: Annual Rate/12* No. of Months.
- For Fractional months in a quarterly bill cycle, the calculation has been done as follows: (Annual Rate/4)* (Days of Service in Quarter/Total No. of days in Quarter).

Complaints & Service Requests

Visit www.jio.com, login with your Jio ID and password; click on "Service Request" option under Profile menu to raise a complaint. To track the status of your existing complaint, use your unique Service Request number. You can also call 198 (toll-free) from your Jio number or 1800 889 9444 from other networks to register your service request / complaint.

JioPay

- JioAutoPay
 - JioAutoPay debit will be on 22nd day following the date of bill.
 - Click to view the process www.jio.com/enterprise/autopay/

Service Accounting Codes (SAC)

SAC Code : Services	SAC Code : Services
998412 : Fixed Line Charges	998431 : Digital VAS Charges
998413 : Mobile Charges	998432 : Online Music Charges
998419 : VAS Charges	998433 : Online Video Charges
998422 : Data Charges	998439 : Online Content Charges
998414 : ILL	

Appellate Authority

In case you are unsatisfied with the response on a complaint, you can contact the regional appellate authority with your complaint docket number.

Email: appellate.ori@jio.com, Telephone number: 1800-889-3999, Fax: 1800-889-1211

Address: Reliance Jio Infocomm Limited, Fortune Tower, 1st Floor,

Wing A & B, Gangadhar Meher Marg, Chandrasekharpur

Bhubaneswar 751023 Odisha

(Working hours: Mon-Fri, 10:30 am to 6:00 pm)

Other Information

- The invoice will be deemed accepted as per the Master Service Agreement or Terms and Conditions signed.
- Reliance Jio Infocomm Limited reserves the right to change, from time to time, the terms and conditions of the contract by giving notice of the change.
- In the event of non-payment, part payment or late payment of the outstanding amount by the due date, or in the case of bounced cheques, Reliance Jio Infocomm Limited reserves the right to disconnect services. The customer shall continue to be liable for the charges during the period of suspension.
- In case of permanent disconnection, your security deposit will be refunded within 60 days of disconnection, failing which you shall be paid interest @10% p.a, following adjustment of dues.
- We request you to log disconnection request through online portal. Please login to www.jio.com/enterprise with your login id and password and click on New Service Request. Alternatively, you may also log disconnection at enterpriseservices@jio.com. Upon receipt of mail, a Service Request no. will be provided to you within 48 Hrs. Please note that In absence of SR number, no credit adjustments shall be made for the delay in disconnection and the customer shall be liable to pay for the charges.
- Goods and Service Tax(GST)and other indirect taxes, as may be applicable will be charged and shown separately over and above the billed amount. Further, any increase/addition/ introduction in taxes and/or levy of any taxes, levies, duties or any other statutory charges etc.,(present/future) shall be charged to the Customer without any notice and shall at all-time be deemed to be payable.
- E-Bills will be sent to the Customer to his e-mail address as mentioned in EAF. For any change in e-mail address, Customer shall intimate Enterprise customer care about new email address at least 15 days prior to the commencement of the next billing cycle. Customer is responsible to pay his bills by the prescribed date. It is incumbent on the Customer to enquire his/her balance and settle the same even in case of non-receipt of monthly bill for any reason whatsoever.
- The payment shall be made in favour of RJIO900250055138.
- RJIL reserve it right to reserve or notify payment institution as part of terms and conditions of invoices or bills whenever applicable.
- No cheque payment will be accepted against wireline services.

6 Months Balance

Sr. No.	Bill Number	Bill Date	Charges (₹)	Adjustments (₹)	Amount Paid (₹)	TDS Deducted (₹)	Balance Amount (₹)
1	521500089748	2022-04-01	825,998.82	0.00	825,998.82	0.00	0.00
2	517000105997	2022-01-01	825,998.82	0.00	825,998.82	0.00	0.00
3	536000102404	2021-10-01	825,998.82	0.00	825,998.82	0.00	0.00
4	524000098477	2021-07-01	825,998.82	0.00	825,998.82	0.00	0.00
5	529500053457	2021-04-01	825,998.82	0.00	825,998.82	0.00	0.00
6	535000072108	2021-01-01	825,998.82	0.00	825,998.82	0.00	0.00
Total							0.00

Payments Received

Sr. No.	Bill Number	Payment Date	Transaction Mode	Balance Amount(₹)
1		2022-04-19	RTGS	825,999.00
Total				825,999.00

Reach Us



Taxes

Sr. No.	Description	Charges	CGST	SGST	Amount (₹)
1	This month charges	699,999.00	62,999.91	62,999.91	125,999.82



DIGITAL LIFE

Jagannath Inst For Tech & Mgmt
Na,Khata No 151/448,
Aluri Nagar R Sitapur Jitm Campus Gajapati,
Parlakhemundi,Gajapati,
Odisha-761200,India

Original for Recipient
Account Number : 900250055138
GST Bill Number :C21E202100017734
Bill Number : 535000072108
Bill Cycle Date : 01-JAN-2021
Invoice Date : 19-JAN-2021
Bill Due Date : 18-JAN-2021

Place of Supply: 21 Odisha

GST Registration Number: 21AAATJ3251E2ZA
Organisation PAN : AAATJ3251E
Invoice Reference Number : 9fe37435f8324b385c6c1e3f7c81196cfeca0907c25bafd99da4f2e4ae9bf927

Your ILL Bill

Refer following pages for details of charges

Payment Received (`)	TDS Deducted / Reversed (`)	Previous Adjustment (`)	Previous Balance (`)	Current Charges (`)	Total Dues (`)
825,999.00	0.00	0.00	-0.36	825,998.82	825,998.46

	Amount(`)
1 Periodic Charges	
Bandwidth Rental	699,999.00
CPE Rental	0.00
SLA	0.00
CoS Charges	0.00
Managed Services	0.00
Secondary Link	0.00
2 Other Periodic Charges	0.00
3 Other Charges	0.00
4 One Time Charges	0.00
5 Total Value of Charges	0.00
6 Current Month Discount / Credit / Debit	0.00
7 Current Taxable Charges	699,999.00
8 Taxes	
CGST (9%)	62,999.91
SGST (9%)	62,999.91
9 Bill Discount including Tax	0.00
10 Security Deposit Charged	0.00
11 Security Deposit Returned	0.00
12 Waiver	0.00
Current Month Charges (7+8+9+10+11+12)	825,998.82

Payment Options



JioAutoPay

ACH - (Direct Debit)

To set ACH mandate on your bank account get in touch with your Relationship Manager.

Standing Instructions (Credit Card)

Set JioAutoPay on your Credit Card.
To register visit www.jio.com/Enterprise/Mobility/ and scroll down on the home page and click on Register for autopay of invoice by credit card.

*Details under Important Information JioPay



JioDigiPay

Selfcare Portal

Pay bills using credit/debit card/netbanking/ e-wallets/UPI on www.jio.com/Enterprise/Mobility/

NEFT/RTGS

You can do NEFT/RTGS payments/transfers by using Virtual A/C Code RJIO900250055138, IFSC Code ICIC0000104

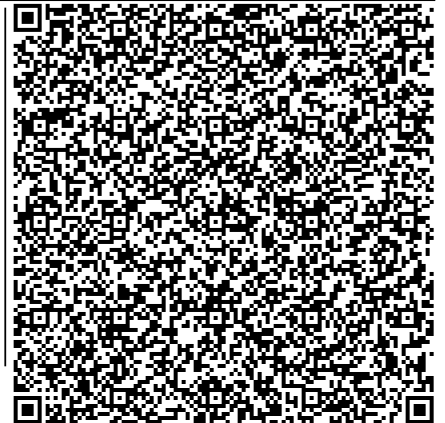

GSTIN: 21AABCI6363G1ZV PAN: AABCI6363G

Registered Office: Reliance Jio Infocomm Limited
Office-101, Saffron, Nr.Centre Point, Panchwati 5 Rasta,
Ambawadi, Ahmedabad-380006, Gujarat, India
CIN: U72900GJ2007PLC105869

State Office: Reliance Jio Infocomm Limited
Wing A & B, 1st Floor,
Fortune Towers, Gangadhar Meher
Marg, Chandrasekharpur,
Bhubaneswar 751023 Odisha

Gst Registered Office: Company
Bhubaneswar, Khurda
1st Floor, Wing-a & B, Fortune Tower, Road -
Chandrasekharpur,
Pincode: 751023 Odisha

**Terms and Conditions****Tariff & Plans**

- There will be no increase in any tariff item the agreed contract Period. Thereafter, Reliance Jio Infocomm Limited reserves the right to revise the terms & conditions applicable to tariff plans.
- RJIL reserves the right to vary the penal charge rates periodically, as well as take recourse to any other action available and considered appropriate, subject to TRAI regulations.
- No charge will be levied for any service without your explicit consent.
- For periodic charges, the calculation has been done as follows: Annual Rate/12* No. of Months.
- For Fractional months in a quarterly bill cycle, the calculation has been done as follows: (Annual Rate/4)* (Days of Service in Quarter/Total No. of days in Quarter).

Complaints & Service Requests

Visit www.jio.com, login with your Jio ID and password; click on "Service Request" option under Profile menu to raise a complaint. To track the status of your existing complaint, use your unique Service Request number. You can also call 198 (toll-free) from your Jio number or 1800 889 9444 from other networks to register your service request / complaint.

JioPay

- JioAutoPay
 - JioAutoPay debit will be on 22nd day following the date of bill.
 - Click to view the process www.jio.com/enterprise/autopay/

Service Accounting Codes (SAC)

SAC Code : Services	SAC Code : Services
998412 : Fixed Line Charges	998431 : Digital VAS Charges
998413 : Mobile Charges	998432 : Online Music Charges
998419 : VAS Charges	998433 : Online Video Charges
998422 : Data Charges	998439 : Online Content Charges
998414 : ILL	

Appellate Authority

In case you are unsatisfied with the response on a complaint, you can contact the regional appellate authority with your complaint docket number.

Email: appellate.ori@jio.com, Telephone number: 1800-889-3999, Fax: 1800-889-1211
Address: Reliance Jio Infocomm Limited, Fortune Tower, 1st Floor,
Wing A & B, Gangadhar Meher Marg, Chandrasekharpur
Bhubaneswar 751023 Odisha
(Working hours: Mon-Fri, 10:30 am to 6:00 pm)

Other Information

- The invoice will be deemed accepted as per the Master Service Agreement or Terms and Conditions signed.
- Reliance Jio Infocomm Limited reserves the right to change, from time to time, the terms and conditions of the contract by giving notice of the change.
- In the event of non-payment, part payment or late payment of the outstanding amount by the due date, or in the case of bounced cheques, Reliance Jio Infocomm Limited reserves the right to disconnect services. The customer shall continue to be liable for the charges during the period of suspension.
- In case of permanent disconnection, your security deposit will be refunded within 60 days of disconnection, failing which you shall be paid interest @10% p.a, following adjustment of dues.
- We request you to log disconnection request through online portal. Please login to www.jio.com/enterprise with your login id and password and click on New Service Request. Alternatively, you may also log disconnection at enterpriseservices@jio.com. Upon receipt of mail, a Service Request no. will be provided to you within 48 Hrs. Please note that In absence of SR number, no credit adjustments shall be made for the delay in disconnection and the customer shall be liable to pay for the charges.
- Goods and Service Tax(GST)and other indirect taxes, as may be applicable will be charged and shown separately over and above the billed amount. Further, any increase/addition/ introduction in taxes and/or levy of any taxes, levies, duties or any other statutory charges etc.,(present/future) shall be charged to the Customer without any notice and shall at all-time be deemed to be payable.
- E-Bills will be sent to the Customer to his e-mail address as mentioned in EAF. For any change in e-mail address, Customer shall intimate Enterprise customer care about new email address at least 15 days prior to the commencement of the next billing cycle. Customer is responsible to pay his bills by the prescribed date. It is incumbent on the Customer to enquire his/her balance and settle the same even in case of non-receipt of monthly bill for any reason whatsoever.
- The payment shall be made in favour of RJIO900250055138.
- RJIL reserve it right to reserve or notify payment institution as part of terms and conditions of invoices or bills whenever applicable.
- No cheque payment will be accepted against wireline services.

6 Months Balance

Sr. No.	Bill Number	Bill Date	Charges ()	Adjustments ()	Amount Paid ()	TDS Deducted ()	Balance Amount ()
1	529000081691	2020-10-01	825,998.82	0.00	825,998.82	0.00	0.00
2	518500041216	2020-07-01	825,998.82	0.00	825,998.82	0.00	0.00
3	553500031788	2020-04-01	904,513.66	0.00	904,513.66	0.00	0.00
Total							0.00

Payments Received

Sr. No.	Bill Number	Payment Date	Transaction Mode	Balance Amount()
1		2020-11-03	RTGS	825,999.00
Total				825,999.00

Reach Us

Call 199 (from a Jio number) or 1800-88-99-444 (from other networks) | Write to enterpriseservices@jio.com | Manage your world of Jio with MyJio app | Visit www.jio.com



DIGITAL
LIFE

Taxes

Sr. No.	Description	Charges	CGST	SGST	Amount (`)
1	This month charges	699,999.00	62,999.91	62,999.91	125,999.82



Product: ILL

Periodic Charges for the Billing Period - Existing Circuit

Per Site Recurring Charges for the Period - 01-Jan-2021 to 31-Mar-2021

Sr. No.	No of Sites	Bandwidth	Bandwidth	CPE	SLA	CoS	Managed Service	Secondary Link	Amount ()
1	1	1000 Mbps	699,999.00	0.00	0.00	0.00	0.00	0.00	699,999.00
Sub Total	1		699,999.00	0.00	0.00	0.00	0.00	0.00	699,999.00

Periodic Charges for the Billing Period - All Circuit

Sr. No.	No of Sites	Bandwidth	Bandwidth	CPE	SLA	CoS	Managed Service	Secondary Link	Amount ()
1	1	1000 Mbps	699,999.00	0.00	0.00	0.00	0.00	0.00	699,999.00
Total	1		699,999.00	0.00	0.00	0.00	0.00	0.00	699,999.00



DIGITAL
LIFE

Jagannath Inst For Tech & Mgmt

Bill Number: 535000072108

Bill Date: 01-JAN-2021

Bandwidth Charges

Sr. No.	Logical/ Circuit ID	Originating Point	Install Date	Bandwidth	Service ID	From Date	To Date	Amount()
1	1.1	Paralakhemundi	19-Feb-20	1000 Mbps	300635744595	01-Jan-21	31-Mar-21	699,999.00
Total	1							699,999.00



DIGITAL LIFE

Jagannath Inst For Tech & Mgmt
Na,Khata No 151/448,
Aluri Nagar R Sitapur Jitm Campus Gajapati,
Parlakhemundi,Gajapati,
Odisha-761200,India

Original for Recipient
Account Number : 900250055138
GST Bill Number : C21E212200002942
Bill Number : 529500053457
Bill Cycle Date : 01-APR-2021
Invoice Date : 12-APR-2021
Bill Due Date : 18-APR-2021

Place of Supply: 21 Odisha

GST Registration Number: 21AAATJ3251E2ZA

Organisation PAN : AAATJ3251E

Invoice Reference Number : 0afeb36849814b357f5d13653dc69471230d5f05ddf242eac3d5751edc5746ab

Your ILL Bill

Refer following pages for details of charges

Payment Received (₹)	TDS Deducted / Reversed (₹)	Previous Adjustment (₹)	Previous Balance (₹)	Current Charges (₹)	Total Dues (₹)
825,999.00	0.00	0.00	-0.54	825,998.82	825,998.28

	Amount(₹)
1 Periodic Charges	
Bandwidth Rental	699,999.00
CPE Rental	0.00
SLA	0.00
CoS Charges	0.00
Managed Services	0.00
Secondary Link	0.00
2 Other Periodic Charges	0.00
3 Other Charges	0.00
4 One Time Charges	0.00
5 Total Value of Charges	0.00
6 Current Month Discount / Credit / Debit	0.00
7 Current Taxable Charges	699,999.00
8 Taxes	
CGST (9%)	62,999.91
SGST (9%)	62,999.91
9 Bill Discount including Tax	0.00
10 Security Deposit Charged	0.00
11 Security Deposit Returned	0.00
12 Waiver	0.00
Current Month Charges (7+8+9+10+11+12)	825,998.82

Payment Options

JioAutoPay

ACH - (Direct Debit)

To set ACH mandate on your bank account get in touch with your Relationship Manager.

Standing Instructions (Credit Card)

Set JioAutoPay on your Credit Card.
To register visit www.jio.com/Enterprise/Mobility/ and scroll down on the home page and click on Register for autopay of invoice by credit card.

*Details under Important Information JioPay

JioDigiPay

Selfcare Portal

Pay bills using credit/debit card/netbanking/ e-wallets/UPI on www.jio.com/Enterprise/Mobility/

NEFT/RTGS

You can do NEFT/RTGS payments/transfers by using Virtual A/C Code RJIO900250055138, IFSC Code ICIC0000104



GSTIN: 21AABCI6363G1ZV PAN: AABCI6363G

Registered Office: Reliance Jio Infocomm Limited
Office-101, Saffron, Nr.Centre Point, Panchwati 5 Rasta,
Ambawadi, Ahmedabad-380006, Gujarat, India
CIN: U72900GJ2007PLC105869

State Office: Reliance Jio Infocomm Limited
Wing A & B, 1st Floor,
Fortune Towers, Gangadhar Meher
Marg, Chandrasekharpur,
Bhubaneswar 751023 Odisha

Gst Registered Office: Company
Bhubaneswar, Khurda
1st Floor, Wing-a & B, Fortune Tower, Road -
Chandrasekharpur,
Pincode: 751023 Odisha



Terms and Conditions

Tariff & Plans

- There will be no increase in any tariff item the agreed contract Period. Thereafter, Reliance Jio Infocomm Limited reserves the right to revise the terms & conditions applicable to tariff plans.
- RJIL reserves the right to vary the penal charge rates periodically, as well as take recourse to any other action available and considered appropriate, subject to TRAI regulations.
- No charge will be levied for any service without your explicit consent.
- For periodic charges, the calculation has been done as follows: Annual Rate/12* No. of Months.
- For Fractional months in a quarterly bill cycle, the calculation has been done as follows: (Annual Rate/4)* (Days of Service in Quarter/Total No. of days in Quarter).

Complaints & Service Requests

Visit www.jio.com, login with your Jio ID and password; click on "Service Request" option under Profile menu to raise a complaint. To track the status of your existing complaint, use your unique Service Request number. You can also call 198 (toll-free) from your Jio number or 1800 889 9444 from other networks to register your service request / complaint.

JioPay

- JioAutoPay
 - JioAutoPay debit will be on 22nd day following the date of bill.
 - Click to view the process www.jio.com/enterprise/autopay/

Service Accounting Codes (SAC)

SAC Code : Services	SAC Code : Services
998412 : Fixed Line Charges	998431 : Digital VAS Charges
998413 : Mobile Charges	998432 : Online Music Charges
998419 : VAS Charges	998433 : Online Video Charges
998422 : Data Charges	998439 : Online Content Charges
998414 : ILL	

Appellate Authority

In case you are unsatisfied with the response on a complaint, you can contact the regional appellate authority with your complaint docket number.

Email: appellate.ori@jio.com, Telephone number: 1800-889-3999, Fax: 1800-889-1211
Address: Reliance Jio Infocomm Limited, Fortune Tower, 1st Floor, Wing A & B, Gangadhar Meher Marg, Chandrasekharpur Bhubaneswar 751023 Odisha
(Working hours: Mon-Fri, 10:30 am to 6:00 pm)

Other Information

- The invoice will be deemed accepted as per the Master Service Agreement or Terms and Conditions signed.
- Reliance Jio Infocomm Limited reserves the right to change, from time to time, the terms and conditions of the contract by giving notice of the change.
- In the event of non-payment, part payment or late payment of the outstanding amount by the due date, or in the case of bounced cheques, Reliance JioInfocomm Limited reserves the right to disconnect services. The customer shall continue to be liable for the charges during the period of suspension.
- In case of permanent disconnection, your security deposit will be refunded within 60 days of disconnection, failing which you shall be paid interest @10% p.a, following adjustment of dues.
- We request you to log disconnection request through online portal. Please login to www.jio.com/enterprise with your login id and password and click on New Service Request. Alternatively, you may also log disconnection at enterpriseservices@jio.com. Upon receipt of mail, a Service Request no. will be provided to you within 48 Hrs. Please note that In absence of SR number, no credit adjustments shall be made for the delay in disconnection and the customer shall be liable to pay for the charges.
- Goods and Service Tax(GST)and other indirect taxes, as may be applicable will be charged and shown separately over and above the billed amount. Further, any increase/addition/ introduction in taxes and/or levy of any taxes, levies, duties or any other statutory charges etc.,(present/future) shall be charged to the Customer without any notice and shall at all-time be deemed to be payable.
- E-Bills will be sent to the Customer to his e-mail address as mentioned in EAF. For any change in e-mail address, Customer shall intimate Enterprise customer care about new email address at least 15 days prior to the commencement of the next billing cycle. Customer is responsible to pay his bills by the prescribed date. It is incumbent on the Customer to enquire his/her balance and settle the same even in case of non-receipt of monthly bill for any reason whatsoever.
- The payment shall be made in favour of RJIO900250055138.
- RJIL reserve it right to reserve or notify payment institution as part of terms and conditions of invoices or bills whenever applicable.
- No cheque payment will be accepted against wireline services.

6 Months Balance

Sr. No.	Bill Number	Bill Date	Charges ()	Adjustments ()	Amount Paid ()	TDS Deducted ()	Balance Amount ()
1	535000072108	2021-01-01	825,998.82	0.00	825,998.82	0.00	0.00
2	529000081691	2020-10-01	825,998.82	0.00	825,998.82	0.00	0.00
3	518500041216	2020-07-01	825,998.82	0.00	825,998.82	0.00	0.00
4	553500031788	2020-04-01	904,513.66	0.00	904,513.66	0.00	0.00
Total							0.00

Payments Received

Sr. No.	Bill Number	Payment Date	Transaction Mode	Balance Amount()
1		2021-01-21	RTGS	825,999.00
Total				825,999.00

Reach Us

Call 199 (from a Jio number) or 1800-88-99-444 (from other networks) | Write to enterpriseservices@jio.com | Manage your world of Jio with MyJio app | Visit www.jio.com



DIGITAL
LIFE

Taxes

Sr. No.	Description	Charges	CGST	SGST	Amount (`)
1	This month charges	699,999.00	62,999.91	62,999.91	125,999.82



Product: ILL

Periodic Charges for the Billing Period - Existing Circuit

Per Site Recurring Charges for the Period - 01-Apr-2021 to 30-Jun-2021

Sr. No.	No of Sites	Bandwidth	Bandwidth	CPE	SLA	CoS	Managed Service	Secondary Link	Amount ()
1	1	1000 Mbps	699,999.00	0.00	0.00	0.00	0.00	0.00	699,999.00
Sub Total	1		699,999.00	0.00	0.00	0.00	0.00	0.00	699,999.00

Periodic Charges for the Billing Period - All Circuit

Sr. No.	No of Sites	Bandwidth	Bandwidth	CPE	SLA	CoS	Managed Service	Secondary Link	Amount ()
1	1	1000 Mbps	699,999.00	0.00	0.00	0.00	0.00	0.00	699,999.00
Total	1		699,999.00	0.00	0.00	0.00	0.00	0.00	699,999.00



DIGITAL
LIFE

Jagannath Inst For Tech & Mgmt

Bill Number: 529500053457

Bill Date: 01-APR-2021

Bandwidth Charges

Sr. No.	Logical/ Circuit ID	Originating Point	Install Date	Bandwidth	Service ID	From Date	To Date	Amount()
1	1.1	Paralakhemundi	19-Feb-20	1000 Mbps	300635744595	01-Apr-21	30-Jun-21	699,999.00
Total	1							699,999.00



DIGITAL LIFE

Jagannath Inst For Tech & Mgmt
Na,Khata No 151/448,
Aluri Nagar R Sitapur Jitm Campus Gajapati,
Parlakhemundi,Gajapati,
Odisha-761200,India

Original for Recipient
Account Number : 900250055138
GST Bill Number : C21E212200010612
Bill Number : 524000098477
Bill Cycle Date : 01-JUL-2021
Invoice Date : 13-JUL-2021
Bill Due Date : 18-JUL-2021

Place of Supply: 21 Odisha

GST Registration Number: 21AAATJ3251E2ZA

Organisation PAN : AAATJ3251E

Invoice Reference Number : 22a617eddb642cdf1eba83d90d5cd0a3d43f8bdcc7b52df4cd0145269ebbee8de

Your ILL Bill

Refer following pages for details of charges

Payment Received (₹)	TDS Deducted / Reversed (₹)	Previous Adjustment (₹)	Previous Balance (₹)	Current Charges (₹)	Total Dues (₹)
825,999.00	0.00	0.00	-0.72	825,998.82	825,998.10

	Amount(₹)
1 Periodic Charges	
Bandwidth Rental	699,999.00
CPE Rental	0.00
SLA	0.00
CoS Charges	0.00
Managed Services	0.00
Secondary Link	0.00
2 Other Periodic Charges	0.00
3 Other Charges	0.00
4 One Time Charges	0.00
5 Total Value of Charges	0.00
6 Current Month Discount / Credit / Debit	0.00
7 Current Taxable Charges	699,999.00
8 Taxes	
CGST (9%)	62,999.91
SGST (9%)	62,999.91
9 Bill Discount including Tax	0.00
10 Security Deposit Charged	0.00
11 Security Deposit Returned	0.00
12 Waiver	0.00
Current Month Charges (7+8+9+10+11+12)	825,998.82

Payment Options



JioPay
Register with JioPay and get uninterrupted services.*

JioAutoPay
 **ACH - (Direct Debit)**
To set ACH mandate on your bank account get in touch with your Relationship Manager.

 **Standing Instructions (Credit Card)**
Set JioAutoPay on your Credit Card.
To register visit www.jio.com/Enterprise/Mobility/ and scroll down on the home page and click on Register for autopay of invoice by credit card.

*Details under Important Information JioPay

JioDigiPay
 **Selfcare Portal**
Pay bills using credit/debit card/netbanking/e-wallets/UPI on www.jio.com/Enterprise/Mobility/

 **NEFT/RTGS**
You can do NEFT/RTGS payments/transfers by using Virtual A/C Code RJIO900250055138, IFSC Code ICIC0000104



GSTIN: 21AABCI6363G1ZV PAN: AABCI6363G

Registered Office: Reliance Jio Infocomm Limited
Office-101, Saffron, Nr.Centre Point, Panchwati 5 Rasta,
Ambawadi, Ahmedabad-380006, Gujarat, India
CIN: U72900GJ2007PLC105869

State Office: Reliance Jio Infocomm Limited
Fortune Tower, 4th Floor Wing - C/2
Gangadhar Meher Marg, Chandrasekharpur,
Bhubaneswar 751023 Odisha

Gst Registered Office: Company
Khordha
C/o Ril-1st Floor Wing A/b Fortune Tower
Chandrasekharpur
Pincode: 751023 Bhubaneswar



Terms and Conditions

Tariff & Plans

- There will be no increase in any tariff item the agreed contract Period. Thereafter, Reliance Jio Infocomm Limited reserves the right to revise the terms & conditions applicable to tariff plans.
- RJIL reserves the right to vary the penal charge rates periodically, as well as take recourse to any other action available and considered appropriate, subject to TRAI regulations.
- No charge will be levied for any service without your explicit consent.
- For periodic charges, the calculation has been done as follows: Annual Rate/12* No. of Months.
- For Fractional months in a quarterly bill cycle, the calculation has been done as follows: (Annual Rate/4)* (Days of Service in Quarter/Total No. of days in Quarter).

Complaints & Service Requests

Visit www.jio.com, login with your Jio ID and password; click on "Service Request" option under Profile menu to raise a complaint. To track the status of your existing complaint, use your unique Service Request number. You can also call 198 (toll-free) from your Jio number or 1800 889 9444 from other networks to register your service request / complaint.

JioPay

- JioAutoPay
 - JioAutoPay debit will be on 22nd day following the date of bill.
 - Click to view the process www.jio.com/enterprise/autopay/

Service Accounting Codes (SAC)

SAC Code : Services	SAC Code : Services
998412 : Fixed Line Charges	998431 : Digital VAS Charges
998413 : Mobile Charges	998432 : Online Music Charges
998419 : VAS Charges	998433 : Online Video Charges
998422 : Data Charges	998439 : Online Content Charges
998414 : ILL	

Appellate Authority

In case you are unsatisfied with the response on a complaint, you can contact the regional appellate authority with your complaint docket number.

Email: appellate.ori@jio.com, Telephone number: 1800-889-3999, Fax: 1800-889-1211
Address: Reliance Jio Infocomm Limited, Fortune Tower, 1st Floor,
Wing A & B, Gangadhar Meher Marg, Chandrasekharpur
Bhubaneswar 751023 Odisha
(Working hours: Mon-Fri, 10:30 am to 6:00 pm)

Other Information

- The invoice will be deemed accepted as per the Master Service Agreement or Terms and Conditions signed.
- Reliance Jio Infocomm Limited reserves the right to change, from time to time, the terms and conditions of the contract by giving notice of the change.
- In the event of non-payment, part payment or late payment of the outstanding amount by the due date, or in the case of bounced cheques, Reliance JioInfocomm Limited reserves the right to disconnect services. The customer shall continue to be liable for the charges during the period of suspension.
- In case of permanent disconnection, your security deposit will be refunded within 60 days of disconnection, failing which you shall be paid interest @10% p.a, following adjustment of dues.
- We request you to log disconnection request through online portal. Please login to www.jio.com/enterprise with your login id and password and click on New Service Request. Alternatively, you may also log disconnection at enterpriseservices@jio.com. Upon receipt of mail, a Service Request no. will be provided to you within 48 Hrs. Please note that In absence of SR number, no credit adjustments shall be made for the delay in disconnection and the customer shall be liable to pay for the charges.
- Goods and Service Tax(GST)and other indirect taxes, as may be applicable will be charged and shown separately over and above the billed amount. Further, any increase/addition/ introduction in taxes and/or levy of any taxes, levies, duties or any other statutory charges etc.,(present/future) shall be charged to the Customer without any notice and shall at all-time be deemed to be payable.
- E-Bills will be sent to the Customer to his e-mail address as mentioned in EAF. For any change in e-mail address, Customer shall intimate Enterprise customer care about new email address at least 15 days prior to the commencement of the next billing cycle. Customer is responsible to pay his bills by the prescribed date. It is incumbent on the Customer to enquire his/her balance and settle the same even in case of non-receipt of monthly bill for any reason whatsoever.
- The payment shall be made in favour of RJIO900250055138.
- RJIL reserve it right to reserve or notify payment institution as part of terms and conditions of invoices or bills whenever applicable.
- No cheque payment will be accepted against wireline services.

6 Months Balance

Sr. No.	Bill Number	Bill Date	Charges ()	Adjustments ()	Amount Paid ()	TDS Deducted ()	Balance Amount ()
1	529500053457	2021-04-01	825,998.82	0.00	825,998.82	0.00	0.00
2	535000072108	2021-01-01	825,998.82	0.00	825,998.82	0.00	0.00
3	529000081691	2020-10-01	825,998.82	0.00	825,998.82	0.00	0.00
4	518500041216	2020-07-01	825,998.82	0.00	825,998.82	0.00	0.00
5	553500031788	2020-04-01	904,513.66	0.00	904,513.66	0.00	0.00
Total							0.00

Payments Received

Sr. No.	Bill Number	Payment Date	Transaction Mode	Balance Amount()
1		2021-04-17	RTGS	825,999.00
Total				825,999.00

Reach Us

Call 199 (from a Jio number) or 1800-88-99-444 (from other networks) | Write to enterpriseservices@jio.com | Manage your world of Jio with MyJio app | Visit www.jio.com



DIGITAL
LIFE

Taxes

Sr. No.	Description	Charges	CGST	SGST	Amount (`)
1	This month charges	699,999.00	62,999.91	62,999.91	125,999.82



Product: ILL

Periodic Charges for the Billing Period - Existing Circuit

Per Site Recurring Charges for the Period - 01-Jul-2021 to 30-Sep-2021

Sr. No.	No of Sites	Bandwidth	Bandwidth	CPE	SLA	CoS	Managed Service	Secondary Link	Amount ()
1	1	1000 Mbps	699,999.00	0.00	0.00	0.00	0.00	0.00	699,999.00
Sub Total	1		699,999.00	0.00	0.00	0.00	0.00	0.00	699,999.00

Periodic Charges for the Billing Period - All Circuit

Sr. No.	No of Sites	Bandwidth	Bandwidth	CPE	SLA	CoS	Managed Service	Secondary Link	Amount ()
1	1	1000 Mbps	699,999.00	0.00	0.00	0.00	0.00	0.00	699,999.00
Total	1		699,999.00	0.00	0.00	0.00	0.00	0.00	699,999.00



DIGITAL
LIFE

Jagannath Inst For Tech & Mgmt

Bill Number: 524000098477

Bill Date: 01-JUL-2021

Bandwidth Charges

Sr. No.	Logical/ Circuit ID	Originating Point	Install Date	Bandwidth	Service ID	From Date	To Date	Amount()
1	1.1	Paralakhemundi	19-Feb-20	1000 Mbps	300635744595	01-Jul-21	30-Sep-21	699,999.00
Total	1							699,999.00



DIGITAL LIFE

Jagannath Inst For Tech & Mgmt
Na,Khata No 151/448,
Aluri Nagar R Sitapur Jitm Campus Gajapati,
Parlakhemundi,Gajapati,
Odisha-761200,India

Original for Recipient
Account Number : 900250055138
GST Bill Number :C21E202100011183
Bill Number : 529000081691
Bill Cycle Date : 01-OCT-2020
Invoice Date : 20-OCT-2020
Bill Due Date : 18-OCT-2020

Place of Supply: 21 Odisha

GST Registration Number: 21AAATJ3251E2ZA
Organisation PAN : AAATJ3251E
Invoice Reference Number : 035dbc48828f53820561327c98a0e23f9e2e86c45801417cee69f4dcef44fda8

Your ILL Bill

Refer following pages for details of charges

Payment Received (`)	TDS Deducted / Reversed (`)	Previous Adjustment (`)	Previous Balance (`)	Current Charges (`)	Total Dues (`)
825,999.00	0.00	0.00	-0.18	825,998.82	825,998.64

	Amount(₹)
1 Periodic Charges	
Bandwidth Rental	699,999.00
CPE Rental	0.00
SLA	0.00
CoS Charges	0.00
Managed Services	0.00
Secondary Link	0.00
2 Other Periodic Charges	0.00
3 Other Charges	0.00
4 One Time Charges	0.00
5 Total Value of Charges	0.00
6 Current Month Discount / Credit / Debit	0.00
7 Current Taxable Charges	699,999.00
8 Taxes	
CGST (9%)	62,999.91
SGST (9%)	62,999.91
9 Bill Discount including Tax	0.00
10 Security Deposit Charged	0.00
11 Security Deposit Returned	0.00
12 Waiver	0.00
Current Month Charges (7+8+9+10+11+12)	825,998.82

Payment Options

JioAutoPay

ACH - (Direct Debit)

To set ACH mandate on your bank account get in touch with your Relationship Manager.

Standing Instructions (Credit Card)

Set JioAutoPay on your Credit Card.
To register visit www.jio.com/Enterprise/Mobility/ and scroll down on the home page and click on Register for autopay of invoice by credit card.

*Details under Important Information JioPay

JioDigiPay

Selfcare Portal

Pay bills using credit/debit card/netbanking/e-wallets/UPI on www.jio.com/Enterprise/Mobility/

NEFT/RTGS

You can do NEFT/RTGS payments/transfers by using Virtual A/C Code RJIO900250055138, IFSC Code ICIC0000104



GSTIN: 21AABCI6363G1ZV PAN: AABCI6363G

Registered Office: Reliance Jio Infocomm Limited
Office-101, Saffron, Nr.Centre Point, Panchwati 5 Rasta,
Ambawadi, Ahmedabad-380006, Gujarat, India
CIN: U72900GJ2007PLC105869

State Office: Reliance Jio Infocomm Limited
Wing A & B, 1st Floor,
Fortune Towers, Gangadhar Meher
Marg, Chandrasekharpur,
Bhubaneswar 751023 Odisha

Gst Registered Office: Company
Bhubaneswar, Khurda
1st Floor, Wing-a & B, Fortune Tower, Road -
Chandrasekharpur,
Pincode: 751023 Odisha

**Terms and Conditions****Tariff & Plans**

- There will be no increase in any tariff item the agreed contract Period. Thereafter, Reliance Jio Infocomm Limited reserves the right to revise the terms & conditions applicable to tariff plans.
- RJIL reserves the right to vary the penal charge rates periodically, as well as take recourse to any other action available and considered appropriate, subject to TRAI regulations.
- No charge will be levied for any service without your explicit consent.
- For periodic charges, the calculation has been done as follows: Annual Rate/12* No. of Months.
- For Fractional months in a quarterly bill cycle, the calculation has been done as follows: (Annual Rate/4)* (Days of Service in Quarter/Total No. of days in Quarter).

Complaints & Service Requests

Visit www.jio.com, login with your Jio ID and password; click on "Service Request" option under Profile menu to raise a complaint. To track the status of your existing complaint, use your unique Service Request number. You can also call 198 (toll-free) from your Jio number or 1800 889 9444 from other networks to register your service request / complaint.

JioPay

- JioAutoPay
 - JioAutoPay debit will be on 22nd day following the date of bill.
 - Click to view the process www.jio.com/enterprise/autopay/

Service Accounting Codes (SAC)

SAC Code : Services	SAC Code : Services
998412 : Fixed Line Charges	998431 : Digital VAS Charges
998413 : Mobile Charges	998432 : Online Music Charges
998419 : VAS Charges	998433 : Online Video Charges
998422 : Data Charges	998439 : Online Content Charges
998414 : ILL	

Appellate Authority

In case you are unsatisfied with the response on a complaint, you can contact the regional appellate authority with your complaint docket number.

Email: appellate.ori@jio.com, Telephone number: 1800-889-3999, Fax: 1800-889-1211
 Address: Reliance Jio Infocomm Limited, Fortune Tower, 1st Floor,
 Wing A & B, Gangadhar Meher Marg, Chandrasekharpur
 Bhubaneswar 751023 Odisha
 (Working hours: Mon-Fri, 10:30 am to 6:00 pm)

Other Information

- The invoice will be deemed accepted as per the Master Service Agreement or Terms and Conditions signed.
- Reliance Jio Infocomm Limited reserves the right to change, from time to time, the terms and conditions of the contract by giving notice of the change.
- In the event of non-payment, part payment or late payment of the outstanding amount by the due date, or in the case of bounced cheques, Reliance Jio Infocomm Limited reserves the right to disconnect services. The customer shall continue to be liable for the charges during the period of suspension.
- In case of permanent disconnection, your security deposit will be refunded within 60 days of disconnection, failing which you shall be paid interest @10% p.a, following adjustment of dues.
- We request you to log disconnection request through online portal. Please login to www.jio.com/enterprise with your login id and password and click on New Service Request. Alternatively, you may also log disconnection at enterpriseservices@jio.com. Upon receipt of mail, a Service Request no. will be provided to you within 48 Hrs. Please note that In absence of SR number, no credit adjustments shall be made for the delay in disconnection and the customer shall be liable to pay for the charges.
- Goods and Service Tax(GST)and other indirect taxes, as may be applicable will be charged and shown separately over and above the billed amount. Further, any increase/addition/ introduction in taxes and/or levy of any taxes, levies, duties or any other statutory charges etc.,(present/future) shall be charged to the Customer without any notice and shall at all-time be deemed to be payable.
- E-Bills will be sent to the Customer to his e-mail address as mentioned in EAF. For any change in e-mail address, Customer shall intimate Enterprise customer care about new email address at least 15 days prior to the commencement of the next billing cycle. Customer is responsible to pay his bills by the prescribed date. It is incumbent on the Customer to enquire his/her balance and settle the same even in case of non-receipt of monthly bill for any reason whatsoever.
- The payment shall be made in favour of RJIO900250055138.
- RJIL reserve it right to reserve or notify payment institution as part of terms and conditions of invoices or bills whenever applicable.
- No cheque payment will be accepted against wireline services.

6 Months Balance

Sr. No.	Bill Number	Bill Date	Charges (₹)	Adjustments (₹)	Amount Paid (₹)	TDS Deducted (₹)	Balance Amount (₹)
1	518500041216	2020-07-01	825,998.82	0.00	825,998.82	0.00	0.00
2	553500031788	2020-04-01	904,513.66	0.00	904,513.66	0.00	0.00
Total							0.00

Payments Received

Sr. No.	Bill Number	Payment Date	Transaction Mode	Balance Amount(₹)
1		2020-07-20	RTGS	825,999.00
Total				825,999.00

Reach Us

Call 199 (from a Jio number) or 1800-88-99-444 (from other networks) | Write to enterpriseservices@jio.com | Manage your world of Jio with MyJio app | Visit www.jio.com



DIGITAL
LIFE

Taxes

Sr. No.	Description	Charges	CGST	SGST	Amount (₹)
1	This month charges	699,999.00	62,999.91	62,999.91	125,999.82



Product: ILL

Periodic Charges for the Billing Period - Existing Circuit

Per Site Recurring Charges for the Period - 01-Oct-2020 to 31-Dec-2020

Sr. No.	No of Sites	Bandwidth	Bandwidth	CPE	SLA	CoS	Managed Service	Secondary Link	Amount (₹)
1	1	1000 Mbps	699,999.00	0.00	0.00	0.00	0.00	0.00	699,999.00
Sub Total	1		699,999.00	0.00	0.00	0.00	0.00	0.00	699,999.00

Periodic Charges for the Billing Period - All Circuit

Sr. No.	No of Sites	Bandwidth	Bandwidth	CPE	SLA	CoS	Managed Service	Secondary Link	Amount (₹)
1	1	1000 Mbps	699,999.00	0.00	0.00	0.00	0.00	0.00	699,999.00
Total	1		699,999.00	0.00	0.00	0.00	0.00	0.00	699,999.00



DIGITAL
LIFE

Jagannath Inst For Tech & Mgmt

Bill Number: 529000081691

Bill Date: 01-OCT-2020

Bandwidth Charges

Sr. No.	Logical/ Circuit ID	Originating Point	Install Date	Bandwidth	Service ID	From Date	To Date	Amount(₹)
1	1.1	Paralakhemundi	19-Feb-20	1000 Mbps	300635744595	01-Oct-20	31-Dec-20	699,999.00
Total	1							699,999.00



DIGITAL LIFE

Jagannath Inst For Tech & Mgmt
Na,Khata No 151/448,
Aluri Nagar R Sitapur Jitm Campus Gajapati,
Parlakhemundi,Gajapati,
Odisha-761200,India

Original for Recipient
Account Number : 900250055138
GST Bill Number : C21E212200016578
Bill Number : 536000102404
Bill Cycle Date : 01-OCT-2021
Invoice Date : 01-OCT-2021
Bill Due Date : 18-OCT-2021

Place of Supply: 21 Odisha

GST Registration Number: 21AAATJ3251E2ZA
Organisation PAN : AAATJ3251E
Invoice Reference Number : ecd878e77b0d5716ad30e393e831829dbf538b1ff037e9f85f734a40cd494f6a

Your ILL Bill

Refer following pages for details of charges

Payment Received (₹)	TDS Deducted / Reversed (₹)	Previous Adjustment (₹)	Previous Balance (₹)	Current Charges (₹)	Total Dues (₹)
825,999.00	0.00	0.00	-0.90	825,998.82	825,997.92

	Amount(₹)
1 Periodic Charges	
Bandwidth Rental	699,999.00
CPE Rental	0.00
SLA	0.00
CoS Charges	0.00
Managed Services	0.00
Secondary Link	0.00
2 Other Periodic Charges	0.00
3 Other Charges	0.00
4 One Time Charges	0.00
5 Total Value of Charges	0.00
6 Current Month Discount / Credit / Debit	0.00
7 Current Taxable Charges	699,999.00
8 Taxes	
CGST (9%)	62,999.91
SGST (9%)	62,999.91
9 Bill Discount including Tax	0.00
10 Security Deposit Charged	0.00
11 Security Deposit Returned	0.00
12 Waiver	0.00
Current Month Charges (7+8+9+10+11+12)	825,998.82

Payment Options

JioAutoPay

JioPay

Register with JioPay and get uninterrupted services.*

e-NACH (Debit Card)
To set e-NACH mandate on your bank account visit www.jio.com/business/

Standing Instructions (Credit Card)
Set JioAutoPay on your Credit Card.
To register visit www.jio.com/business/ and click on Register for autopay of invoice by credit card.

*Details under Important Information JioPay

JioDigiPay

Selfcare Portal
Pay bills using credit/debit card/netbanking/e-wallets/UPI on www.jio.com/business/

NEFT/RTGS
You can do NEFT/RTGS payments/transfers by using Virtual A/C Code RJIO900250055138, IFSC Code ICIC0000104



GSTIN: 21AABCI6363G1ZV PAN: AABCI6363G

Registered Office: Reliance Jio Infocomm Limited
Office-101, Saffron, Nr.Centre Point, Panchwati 5 Rasta,
Ambawadi, Ahmedabad-380006, Gujarat, India
CIN: U72900GJ2007PLC105869

State Office: Reliance Jio Infocomm Limited
Fortune Tower, 4th Floor Wing - C/2
Gangadhar Meher Marg, Chandrasekharpur,
Bhubaneswar 751023 Odisha

Gst Registered Office: Company
Khordha
C/o Rii-1st Floor Wing A/b Fortune Tower
Chandrasekharpur
Pincode: 751023 Bhubaneswar

**Terms and Conditions****Tariff & Plans**

- There will be no increase in any tariff item the agreed contract Period. Thereafter, Reliance Jio Infocomm Limited reserves the right to revise the terms & conditions applicable to tariff plans.
- RJIL reserves the right to vary the penal charge rates periodically, as well as take recourse to any other action available and considered appropriate, subject to TRAI regulations.
- No charge will be levied for any service without your explicit consent.
- For periodic charges, the calculation has been done as follows: Annual Rate/12* No. of Months.
- For Fractional months in a quarterly bill cycle, the calculation has been done as follows: (Annual Rate/4)* (Days of Service in Quarter/Total No. of days in Quarter).

Complaints & Service Requests

Visit www.jio.com, login with your Jio ID and password; click on "Service Request" option under Profile menu to raise a complaint. To track the status of your existing complaint, use your unique Service Request number. You can also call 198 (toll-free) from your Jio number or 1800 889 9444 from other networks to register your service request / complaint.

JioPay

- JioAutoPay
 - JioAutoPay debit will be on 22nd day following the date of bill.
 - Click to view the process www.jio.com/enterprise/autopay/

Service Accounting Codes (SAC)

SAC Code : Services	SAC Code : Services
998412 : Fixed Line Charges	998431 : Digital VAS Charges
998413 : Mobile Charges	998432 : Online Music Charges
998419 : VAS Charges	998433 : Online Video Charges
998422 : Data Charges	998439 : Online Content Charges
998414 : ILL	

Appellate Authority

In case you are unsatisfied with the response on a complaint, you can contact the regional appellate authority with your complaint docket number.

Email: appellate.ori@jio.com, Telephone number: 1800-889-3999, Fax: 1800-889-1211
Address: Reliance Jio Infocomm Limited, Fortune Tower, 1st Floor,
Wing A & B, Gangadhar Meher Marg, Chandrasekharpur
Bhubaneswar 751023 Odisha
(Working hours: Mon-Fri, 10:30 am to 6:00 pm)

Other Information

- The invoice will be deemed accepted as per the Master Service Agreement or Terms and Conditions signed.
- Reliance Jio Infocomm Limited reserves the right to change, from time to time, the terms and conditions of the contract by giving notice of the change.
- In the event of non-payment, part payment or late payment of the outstanding amount by the due date, or in the case of bounced cheques, Reliance Jio Infocomm Limited reserves the right to disconnect services. The customer shall continue to be liable for the charges during the period of suspension.
- In case of permanent disconnection, your security deposit will be refunded within 60 days of disconnection, failing which you shall be paid interest @10% p.a. following adjustment of dues.
- We request you to log disconnection request through online portal. Please login to www.jio.com/enterprise with your login id and password and click on New Service Request. Alternatively, you may also log disconnection at enterpriseservices@jio.com. Upon receipt of mail, a Service Request no. will be provided to you within 48 Hrs. Please note that In absence of SR number, no credit adjustments shall be made for the delay in disconnection and the customer shall be liable to pay for the charges.
- Goods and Service Tax(GST)and other indirect taxes, as may be applicable will be charged and shown separately over and above the billed amount. Further, any increase/addition/introduction in taxes and/or levy of any taxes, levies, duties or any other statutory charges etc..(present/future) shall be charged to the Customer without any notice and shall at all-time be deemed to be payable.
- E-Bills will be sent to the Customer to his e-mail address as mentioned in EAF. For any change in e-mail address, Customer shall intimate Enterprise customer care about new email address at least 15 days prior to the commencement of the next billing cycle. Customer is responsible to pay his bills by the prescribed date. It is incumbent on the Customer to enquire his/her balance and settle the same even in case of non-receipt of monthly bill for any reason whatsoever.
- The payment shall be made in favour of RJIO900250055138.
- RJIL reserve it right to reserve or notify payment institution as part of terms and conditions of invoices or bills whenever applicable.
- No cheque payment will be accepted against wireline services.

6 Months Balance

Sr. No.	Bill Number	Bill Date	Charges ()	Adjustments ()	Amount Paid ()	TDS Deducted ()	Balance Amount ()
1	524000098477	2021-07-01	825,998.82	0.00	825,998.82	0.00	0.00
2	529500053457	2021-04-01	825,998.82	0.00	825,998.82	0.00	0.00
3	535000072108	2021-01-01	825,998.82	0.00	825,998.82	0.00	0.00
4	529000081691	2020-10-01	825,998.82	0.00	825,998.82	0.00	0.00
5	518500041216	2020-07-01	825,998.82	0.00	825,998.82	0.00	0.00
6	553500031788	2020-04-01	904,513.66	0.00	904,513.66	0.00	0.00
Total							0.00

Payments Received

Sr. No.	Bill Number	Payment Date	Transaction Mode	Balance Amount()
1		2021-07-16	RTGS	825,999.00
Total				825,999.00

Reach Us



Taxes

Sr. No.	Description	Charges	CGST	SGST	Amount (`)
1	This month charges	699,999.00	62,999.91	62,999.91	125,999.82



DIGITAL LIFE

Jagannath Inst For Tech & Mgmt
Na,Khata No 151/448,
Aluri Nagar R Sitapur Jitm Campus Gajapati,
Parlakhemundi,Gajapati,
Odisha-761200,India

Original for Recipient

Account Number : 900250055138
GST Bill Number :C21E202100000077
Bill Number : 553500031788
Bill Date : 01-APR-2020
Bill Due Date : 18-APR-2020

Place of Supply: 21 Odisha

GST Registration Number: 21AAATJ3251E2ZA
Organisation PAN : AAATJ3251E

Your ILL Bill

Refer following pages for details of charges

Payment Received (₹)	TDS Deducted / Reversed (₹)	Previous Adjustment (₹)	Previous Balance (₹)	Current Charges (₹)	Total Dues (₹)
0.00	0.00	0.00	0.00	904,513.66	904,513.66

	Amount(₹)
1 Periodic Charges	
Bandwidth Rental	0.00
CPE Rental	0.00
SLA	0.00
CoS Charges	0.00
Managed Services	0.00
Secondary Link	0.00
2 Other Periodic Charges	0.00
3 Other Charges	761537.00
4 One Time Charges	5,000.00
5 Total Value of Charges	0.00
6 Current Month Discount / Credit / Debit	0.00
7 Current Taxable Charges	766,537.00
8 Taxes	
CGST (9%)	68,988.33
SGST (9%)	68,988.33
9 Bill Discount including Tax	0.00
10 Security Deposit Charged	0.00
11 Security Deposit Returned	0.00
Current Month Charges (7+8+9+10+11)	904,513.66

Payment Options



JioPay

Register with JioPay and get uninterrupted services.*

JioAutoPay



ACH - (Direct Debit)

To set ACH mandate on your bank account get in touch with your Relationship Manager.



Standing Instructions (Credit Card)

Set JioAutoPay on your Credit Card.

To register visit www.jio.com/Enterprise/Mobility/ and scroll down on the home page and click on Register for autopay of invoice by credit card.

JioDigiPay



Selfcare Portal

Pay bills using credit/debit card/netbanking/ e-wallets/UPI on www.jio.com/Enterprise



NEFT/RTGS

You can do NEFT/RTGS payments/transfers by using Virtual A/C Code RJIL900250055138, IFSC Code ICIC0000104

*Details under Important Information JioPay

**Terms and Conditions****Tariff & Plans**

- There will be no increase in any tariff item the agreed contract Period. Thereafter, Reliance Jio Infocomm Limited reserves the right to revise the terms & conditions applicable to tariff plans.
- RJIL reserves the right to vary the penal charge rates periodically, as well as take recourse to any other action available and considered appropriate, subject to TRAI regulations.
- No charge will be levied for any service without your explicit consent.
- For periodic charges, the calculation has been done as follows: Annual Rate/12* No. of Months.
- For Fractional months in a quarterly bill cycle, the calculation has been done as follows: (Annual Rate/4)* (Days of Service in Quarter/Total No. of days in Quarter).

Complaints & Service Requests

Visit www.jio.com, login with your Jio ID and password; click on "Service Request" option under Profile menu to raise a complaint. To track the status of your existing complaint, use your unique Service Request number. You can also call 198 (toll-free) from your Jio number or 1800 889 9444 from other networks to register your service request / complaint.

JioPay

- JioAutoPay
 - JioAutoPay debit will be on 22nd day following the date of bill.
 - Click to view the process www.jio.com/enterprise/autopay/

Service Accounting Codes (SAC)

SAC Code : Services	SAC Code : Services
998412 : Fixed Line Charges	998431 : Digital VAS Charges
998413 : Mobile Charges	998432 : Online Music Charges
998419 : VAS Charges	998433 : Online Video Charges
998422 : Data Charges	998439 : Online Content Charges
998414 : ILL	

Appellate Authority

In case you are unsatisfied with the response on a complaint, you can contact the regional appellate authority with your complaint docket number.

Email: appellate.ori@jio.com, Telephone number: 1800-889-3999, Fax: 1800-889-1211

Address: Reliance Jio Infocomm Limited, Fortune Tower, 1st Floor,

Wing A & B, Gangadhar Meher Marg, Chandrasekharpur

Bhubaneswar 751023 Odisha

(Working hours: Mon-Fri, 10:30 am to 6:00 pm)

Other Information

- The invoice will be deemed accepted as per the Master Service Agreement or Terms and Conditions signed.
- Reliance Jio Infocomm Limited reserves the right to change, from time to time, the terms and conditions of the contract by giving notice of the change.
- In the event of non-payment, part payment or late payment of the outstanding amount by the due date, or in the case of bounced cheques, Reliance Jio Infocomm Limited reserves the right to disconnect services. The customer shall continue to be liable for the charges during the period of suspension.
- In case of permanent disconnection, your security deposit will be refunded within 60 days of disconnection, failing which you shall be paid interest @10% p.a, following adjustment of dues.
- We request you to log disconnection request through online portal. Please login to www.jio.com/enterprise with your login id and password and click on New Service Request. Alternatively, you may also log disconnection at enterpriseservices@jio.com. Upon receipt of mail, a Service Request no. will be provided to you within 48 Hrs. Please note that In absence of SR number, no credit adjustments shall be made for the delay in disconnection and the customer shall be liable to pay for the charges.
- Goods and Service Tax(GST)and other indirect taxes, as may be applicable will be charged and shown separately over and above the billed amount. Further, any increase/addition/ introduction in taxes and/or levy of any taxes, levies, duties or any other statutory charges etc.,(present/future) shall be charged to the Customer without any notice and shall at all-time be deemed to be payable.
- E-Bills will be sent to the Customer to his e-mail address as mentioned in EAF. For any change in e-mail address, Customer shall intimate Enterprise customer care about new email address at least 15 days prior to the commencement of the next billing cycle. Customer is responsible to pay his bills by the prescribed date. It is incumbent on the Customer to enquire his/her balance and settle the same even in case of non-receipt of monthly bill for any reason whatsoever.
- The payment shall be made in favour of RJIL900250055138.
- RJIL reserve it right to reserve or notify payment institution as part of terms and conditions of invoices or bills whenever applicable.
- No cheque payment will be accepted against wireline services.

Authorised Signatory

Taxes

Sr. No.	Description	Charges	CGST	SGST	Amount (₹)
1	This month charges	766,537.00	68,988.33	68,988.33	137,976.66

Reach Us

Call 199 (from a Jio number) or 1800-88-99-444 (from other networks)

Write to enterpriseservices@jio.com

Manage your world of Jio with MyJio app

Visit www.jio.com

Registered Office: Reliance Jio Infocomm Limited
Office-101, Saffron, Nr.Centre Point, Panchwati 5 Rasta,
Ambawadi, Ahmedabad-380006, Gujarat, India
CIN: U72900GJ2007PLC105869

State Office: Reliance Jio Infocomm Limited
Wing A & B, 1st Floor,
Fortune Towers, Gangadhar Meher
Marg, Chandrasekharpur,
Bhubaneswar 751023 Odisha

Gst Registered Office: Company

Bhubaneswar, Khurda
1st Floor, Wing-a & B, Fortune Tower, Road -
Chandrasekharpur,
Pincode: 751023 Odisha



Product: ILL

Security Deposit & One Time Charges

Sr. No.	No of Sites	Per Site One Time Charges			Charges Billed			Amount (₹)
		Installation	Program Mgmt	Security Deposit	Installation	Program Mgmt	Security Deposit	
1	1	5,000.00	0.00	0.00	5,000.00	0.00	0.00	5,000.00
Total	1				5,000.00	0.00	0.00	5,000.00

Other Charge

Sr. No.	No. of Site	Description	Amount(₹)
1	1	Periodic Charges for ILL	761537.00
TOTAL			761537.00



Charges in Detail

Security Deposit & One Time Charges

Sr. No.	Logical/ Circuit ID	Originating Point	Install Date	Service ID	Installation	Program Mgmt	Security Deposit	Amount(₹)
1	1.1	Parlakhemundi	19-Feb-20	300635744595	5,000.00	0.00	0.00	5,000.00
Total	1				5,000.00	0.00	0.00	5,000.00

Other Charges

Sr. No.	Logical/ Circuit ID	Originating Point	Install Date	Description	Service ID	Date	Amount (₹)
1	1.1	Parlakhemundi	19-FEB-2020	Periodic Charges for ILL	300635744595	31-MAR-2020	761537.00
TOTAL							761537.00



Centurion
UNIVERSITY

BHUBANESWAR CAMPUS

INTERNET BILL WITH BAND WIDTH



Paralakhemundi Campus: At - Village Alluri Nagar, P.O - R Sitapur, Via - Uppalada, Paralakhemundi - 761 211, Dist: Gajapati, Odisha, Phone: (06815) 222999

Bhubaneswar Campus: At - Ramachandrapur, P.O - Jatni, Bhubaneswar - 752050, Dist: Khurda, Odisha, Phone: (0674) 2492496

Corporate Office: At - HIG - 4, Jaydev Vihar, Opp. Pal Heights, Bhubaneswar - 751013, Dist: Khurda, Odisha, India.

Website: www.cutm.ac.in

centurion university of technology and management

Shaping Lives... Empowering Communities...



BHARAT SANCHAR NIGAM LIMITED

BHUBANESWAR TELECOM DISTRICT

Centurian University Of Technology
BBR3199925021900020

25-02-2019 AT 31999, Door Sanchar Bh

1000182525

7000240668
531000/-

Inr(s) Five Lakh Thirty-One Thousand Only
023732 / 25-02-2019

BANK: Oriental Bank Of Commerce
LEASED CIRCUIT

CHEQUE USER:b198304672

Supplier's Address: 853, BSNL Bhawan, Ashok Nagar, Unit-2, Bhubaneswar, Khorda-751009, Odisha

Name & Communication Address of the Customer
M/S CENTURIAN UNIVERSITY OF TECHNOLOGY
RAMACHANDRAPUR JATNI KHURDA
-ODISHA . IN
-BHUBANESWAR
751111
India

Leased Circuit Bill/Tax Invoice*

Customer ID 7000237945
Account Number 7000240668
Invoice Number NDCOR0000033742
Invoice Date 03/02/2019
Customer Type LEASED CIRCUIT
Leased Circuit id 1000182525
Due Date 26/02/2019

Customer GSTIN:
Deposit 0.00
Account Summary

Legacy Circuit Id 674#/00203/45/674#

Reverse Charge Applicability: No

Previous Balance	Last Payment	Adjustments	Current Charges	Account Balance	Amount Payable
531000.00	531000.00	0.00	531000.00	531000.00	531000.00 (Rounded Up)

Amount In Words: Five Lakhs Thirty-One Thousand Rupees and Zero Paise

Dear Customer, now you can update your GSTIN details with BSNL, online at
<http://dq.ndc.bsnl.co.in/lporat>

Lead A/Bill to Address:-
RAMACHANDRAPUR JATANI . KHURDA . BBR-KHURDA IN
752050

Lead B Address:-
MAIN TELEPHONE BHAWAN UNIT-3 . BBR KHURDA IN
751001

Summary of Current Charges

Description	Amount(Rs)
Recurring Charges	450000.00
One Time Charges	0.00
Usage Charges	0.00
Discount	0.00
Tax	81000.00
Total Charges	531000.00

Circuit Type :P2P-LOCAL/ 1 GBPS LLA:-0 LLB :-0 CHD :-0 NON-MLLN

Payment Details
Description Date Amount(Rs.)

Payments 12/03/18 531000.00

Recurring Charges

Product	Plan	Period	Qty	Rate	Charges
Circuit Rent-SAC-9984	P2P Circuit	01/04/19 to 31/03/20	NA	NA	450000.00
Modem Discount-HSN-9973	P2P Circuit	01/04/19 to 31/03/20	1	0.00	0.00
Modem_2 Mbps Ethemet-HSN-9973	P2P Circuit	01/04/19 to 31/03/20	1	0.00	0.00
Modem_2 Mbps Ethemet-HSN-9973	P2P Circuit	01/04/19 to 31/03/20	1	0.00	0.00
Total Charges (Rs.)					450000.00

Tax Details

Description	Tax Rate	Amount	Taxable Value
CGST	9.00%	40500.00	450000.00
SGST/UTGST	9.00%	40500.00	450000.00

GST REGISTRATION NUMBER:21AABCBS576G1ZX

PAN NUMBER AABCBS576G

CIN: U74899DL2000G01107739

Handwritten signature

Dear Customer Please dial toll free
1800-425-1957 (24 Hour) for any complaint
regarding leased circuit.

Accounts Officer (TR)

This is a Computer generated Bill and hence does
not require any Signature.

*Original For Recipient/Duplicate For Supplier

Invoice No: NDCOR0000033742	BHARAT SANCHAR NIGAM LTD	Counter Foil
Invoice Date: 03/02/2019		Account No.: 7000240668
Due Date: 26/02/2019		Leased Circuit id.: 1000182525
		Amount Payable: 531000.00
Mode of payment	<input type="checkbox"/> Cash	<input type="checkbox"/> Cheque/DD
Cheque/DD No	<input type="checkbox"/> Credit / Debit Card	<input type="checkbox"/> E-payment
Please Charge Rs.	<input type="checkbox"/> Bank	<input type="checkbox"/> EFT
Expiry Date	Against Card no.	Branch
	Signature	<input type="checkbox"/> Visa <input type="checkbox"/> Masters <input type="checkbox"/> Diners <input type="checkbox"/> Amex
Please make crossed Cheque/DD/Pay order for Amount Payable (Rounded Up) in favour of AO (Cash) BSNL BHUBANESWAR		



BHARAT SANCHAR NIGAM LIMITED

BHUBANESWAR TELECOM DISTRICT

BSNL

Centurian University Of Technology
BBR3010312031800019

12-03-2018 AT 30103,Door Sanchar Ke

1000182525

7000240668
531000/-

Inr(s) Five Lakh Thirty-One Thousand Only
021632 / 09-03-2018

BANK: Oriental Bank Of Commerce
LEASED CIRCUIT

CHEQUE USER:b198304672

Name & Communication Address of the Customer:
M/S CENTURIAN UNIVERSITY OF TECHNOLOGY
RAMACHANDRAPUR JATNI KHURDA
-ODISHA - IN
-BHUBANESWAR
751111
India

Leased Circuit Bill / Tax Invoice*

Customer ID: 7000237945
Account Number: 7000240668
Invoice Number: NDCOR0000007986
Invoice Date: 03/02/2018
Customer Type: LEASED CIRCUIT
Leased Circuit Id: 1000182525
Due Date: 26/02/2018
Reverse Charge Applicability: No

Customer GSTIN
Deposit: 0.00

Legacy Circuit Id: 874#00203/45/574#

Account Summary

Previous Balance	Last Payment	Adjustments	Current Charges	Account Balance	Amount Payable
0.00	0.00	0.00	531000.00	531000.00	531000.00 <small>(Rounded Up)</small>

Amount In Words : Five Lakhs Thirty-One Thousand Rupees and Zero Paise

Dear Customer, now you can update your GSTIN details with BSNL, online at
<http://dq.ncc.bsnl.co.in/portal>

Lead A/Bill to Address -
RAMACHANDRAPUR JATNI, KHURDA, BBR,
KHURDA IN 752090

Lead B Address -
MAIN TELEPHONE SHAWAN UNIT-3, BBR KHURDA
IN 751001

Summary of Current Charges Amount (Rs.)

Recurring Charges	450000.00
One Time Charges	0.00
Usage Charges	0.00
Discount	0.00
Tax	81000.00
Total Charges	531000.00

Circuit Type P2P-LOCAL /	1 GBPS	LLA - 0	LLB - 0	CHD - 0	NON-MLLN
Recurring Charges	Plan	Period	Qty	Rate	Charges
Circuit Rent-SAC-9984	P2P Circuit	01/04/18 to 31/03/19	NA	NA	450000.00
Modem Discount-HSN-9973	P2P Circuit	01/04/18 to 31/03/19	1	0.00	0.00
Modem_2 Mbps Ethernet-HSN-9973	P2P Circuit	01/04/18 to 31/03/19	1	0.00	0.00
Modem_2 Mbps Ethernet-HSN-9973	P2P Circuit	01/04/18 to 31/03/19	1	0.00	0.00
Total Charges (Rs.)					450000.00

Tax Details			
Description	Tax Rate	Amount	Taxable Value
CGST	9.00%	40500.00	450000.00
SGST/UTGST	9.00%	40500.00	450000.00

Please pay my amt
Ch.
9/2/2018

Dear Customer Please dial toll free
1800-425-1957 (24 Hour) for any complaint
regarding leased circuit.

Accounts Officer (TR)
"Please pay current bill amount only, if the
previous bill amount has already been paid."

This is a Computer generated Bill and hence
does not require any Signature.

* Original for recipient / Duplicate for Supplier

E & OE

Counter Foil

Invoice No.: NDCOR0000007986 Invoice Date: 03/02/2018 Due Date: 26/02/2018	BHARAT SANCHAR NIGAM LTD 	Account No.: 7000240668 LeasedCircuit Id.: 1000182525 Amount Due : 531000.00
Mode of payment: <input type="checkbox"/> Cash <input type="checkbox"/> Cheque/DD <input type="checkbox"/> Credit / Debit Card <input type="checkbox"/> E-payment <input type="checkbox"/> EFT		
Cheque/DD No. _____ Dated: [][]/[][]/[][] Bank _____ Branch _____		
Please Charge Rs. _____ Against Card no. _____ <input type="checkbox"/> Visa <input type="checkbox"/> Masters <input type="checkbox"/> Diners <input type="checkbox"/> Amex		
Expiry Date: [][]/[][]/[][] Signature: _____ Card Holder's Name: _____		
Please make crossed Cheque/DD/Pay order for Amount Payable(Round up) in favour of AO (Cash),BSNL, BHUBANESWAR Note: Post Offices / Banks to accept Bills against Account Number on or before Due Date only		

GST Registration Number: 21AACCB5570G1ZX

PAN Number: AACCB55679G

CIN: U74899DL2000G01107139



Centurion
UNIVERSITY

BOLANGIR CAMPUS

INTERNET BILL WITH BAND WIDTH



Paralakhemundi Campus: At - Village Alluri Nagar, P.O - R Sitapur, Via - Uppalada, Paralakhemundi - 761 211, Dist: Gajapati, Odisha, Phone: (06815) 222999

Bhubaneswar Campus: At - Ramachandrapur, P.O - Jatni, Bhubaneswar - 752050, Dist: Khurda, Odisha, Phone: (0674) 2492496

Corporate Office: At - HIG - 4, Jaydev Vihar, Opp. Pal Heights, Bhubaneswar - 751013, Dist: Khurda, Odisha, India.

Website: www.cutm.ac.in

centurion university of technology and management

Shaping Lives... Empowering Communities...

37

Minet Communication

Vandana Complex, Cacheri Chowk Priyadarshini Talkies Road,
Balangir, OR (21) 767001, IN
+918114514343
minetcommunication@gmail.com
GSTIN: 21ANFPN2648M1ZV Website: www.minet.in
Contact Name: Prasenjit Nayak

Amount Due:

₹5,000.00

Issue Date: 02-Jul-2022
Due Date: 02-Jul-2022
Place of Supply: OR (21)

Bill To
JITM College

jitm_sc_mcbo
Near RTO Office Palace Line, Balangir, OR (21) 767001, IN
ashishkumar.mishra@cutm.ac.in 9337978928
GSTIN: 21AAATJ3251E2ZA

Ship To

jitm_sc_mcbo
Balangir, OR (21) 767001, IN

S.No	Item Description	HSN/SAC	Qty UoM	Price (₹)	Taxable Value (₹)	CGST (₹)	SGST (₹)	Amount (₹)
1	PACE1000 Speed Upto 25 Mbps Validity: 30 Days	998422	1	847.50	847.50	76.28 9%	76.28 9%	1,000.06
2	PACE1000 Speed Upto 25 Mbps Validity: 30 Days	998422	1	847.50	847.50	76.28 9%	76.28 9%	1,000.06
3	PACE1000 Speed Upto 25 Mbps Validity: 30 Days	998422	1	847.50	847.50	76.28 9%	76.28 9%	1,000.06
4	PACE1000 Speed Upto 25 Mbps Validity: 30 Days	998422	1	847.50	847.50	76.28 9%	76.28 9%	1,000.06
5	PACE1000 Speed Upto 25 Mbps Validity: 30 Days	998422	1	847.50	847.50	76.28 9%	76.28 9%	1,000.06
5 Total @18%					4,237.50	381.40	381.40	5,000.30

Bank Name: HDFC BANK
Account Number: 50200041046621
Branch Name: HDFC BALANGIR
IFSC Code: HDFC0002693

Total Taxable Value ₹4,237.50
Rounded Off (-) ₹0.30
Total Value (in figure) ₹5,000
Total Value (in words) ₹ Five Thousand Only

Terms & Conditions

Bill For Month Of June-2022

MINET COMMUNICATION
Prasenjit Nayak
PROPRIETOR

Prasenjit Nayak

Prasenjit Nayak

minet Communication

Vandana Complex, Cacheri Chowk Priyadarshini Talkies Road,
Balangir, OR (21) 767001, IN
+918114814343
minetcommunication@gmail.com
GSTIN: 21ANFPN2648M1ZV Website: www.minet.in
Contact Name: Prasenjit Nayak

Amount Due: ₹6,450.00

Issue Date: 01 - Mar - 2022
Due Date: 08 - Mar - 2022
Place of Supply: OR (21)

Bill To
JITM College

jitm_sc_mcbo
Near RTO Office Palace Line, Balangir, OR (21) 767001, IN
ashishkumar.mishra@cutm.ac.in 9337978928
GSTIN: 21AAATJ3251E2ZA

Ship To

jitm_sc_mcbo
Balangir, OR (21) 767001, IN

S.No	Item Description	HSN/SAC	Qty UoM	Price (₹)	Taxable Value (₹)	CGST (₹)	SGST (₹)	Amount (₹)
1	PACE1000 Speed Upto 25 Mbps Validity: 30 Days	998422	1	847.50	847.50	76.28 9%	76.28 9%	1,000.06
2	PACE1000 Speed Upto 25 Mbps Validity: 30 Days	998422	1	847.50	847.50	76.28 9%	76.28 9%	1,000.06
3	PACE1000 Speed Upto 25 Mbps Validity: 30 Days	998422	1	847.50	847.50	76.28 9%	76.28 9%	1,000.06
4	PACE1000 Speed Upto 25 Mbps Validity: 30 Days	998422	1	847.50	847.50	76.28 9%	76.28 9%	1,000.06
5	D-Link Cat 6 Networking Cable UTP Outdoor	85444999	70	35.00	2,450.00	0.00 0%	0.00 0%	2,450.00
			74 Total	@0%	2,450.00	0.00	0.00	2,450.00
				@18%	3,390.00	305.12	305.12	4,000.24

Total Taxable Value ₹5,840.00
Rounded Off (-) ₹0.24
Total Value (in figure) ₹6,450
Total Value (in words) ₹ Six Thousand Four Hundred Fifty Only

Terms & Conditions

Bill For Month Of February-2022

MINET COMMUNICATION
Prasenjit Nayak
PROPRIETOR

Prasenjit Nayak

Minet Communication

Vandana Complex, Cacheri Chowk Priyadarshini Talkies Road,
Balangir, OR (21) 767001, IN
+919114814343
minetcommunication@gmail.com
GSTIN: 21ANFPN2648M1ZV Website: www.minet.in
Contact Name: Prasenjit Nayak

Amount Due:

₹5,000.00

Issue Date: 02-Jul-2022
Due Date: 02-Jul-2022
Place of Supply: OR(21)

Bill To:
JITM College

jitm_sc_mcbo
Near RTO Office Palace Lane, Balangir, OR (21) 767001, IN
ashishkumar.mishra@cutm.ac.in 9337978928
GSTIN: 21AAATJ3251E2ZA

Ship To

jitm_sc_mcbo
Balangir, OR (21) 767001, IN

S.No	Item Description	HSN/SAC	Qty UoM	Price (₹)	Taxable Value (₹)	CGST (₹)	SGST (₹)	Amount (₹)
1	PACE1000 Speed Upto 25 Mbps Validity: 30 Days	998422	1	847.50	847.50	76.28 9%	76.28 9%	1,000.06
2	PACE1000 Speed Upto 25 Mbps Validity: 30 Days	998422	1	847.50	847.50	76.28 9%	76.28 9%	1,000.06
3	PACE1000 Speed Upto 25 Mbps Validity: 30 Days	998422	1	847.50	847.50	76.28 9%	76.28 9%	1,000.06
4	PACE1000 Speed Upto 25 Mbps Validity: 30 Days	998422	1	847.50	847.50	76.28 9%	76.28 9%	1,000.06
5	PACE1000 Speed Upto 25 Mbps Validity: 30 Days	998422	1	847.50	847.50	76.28 9%	76.28 9%	1,000.06
5 Total @18%					4,237.50	381.40	381.40	5,000.30

Bank Name: HDFC BANK
Account Number: 50200041046621
Branch Name: HDFC BALANGIR
IFSC Code: HDFC0002653

Total Taxable Value ₹4,237.50
Rounded Off (-) ₹0.30
Total Value (in figure) ₹5,000
Total Value (in words) ₹ Five Thousand Only

Terms & Conditions

Bill For Month Of June-2022

MINET COMMUNICATION
Prasenjit Nayak
PROPRIETOR

Prasenjit Nayak

Prasenjit

minet Communication

Vandana Complex, Cacheri Chowk Priyadarshini Talkies Road,
Balangir, OR (21) 767001, IN
+918114814343
minetcommunication@gmail.com
GSTIN: 21ANFPN2648M1ZV Website: www.minet.in
Contact Name: Prasenjit Nayak

Amount Due:

₹5,000.00

Issue Date:

01 - Mar - 2022

Due Date:

08 - Mar - 2022

Place of Supply:

OR (21)

Bill To
JITM College

jitm_sc_mcbo
Near RTO Office Palace Line, Balangir, OR (21) 767001, IN
ashishkumar.mishra@cutm.ac.in 9337978928
GSTIN: 21AAATJ3251E2ZA

Ship To

jitm_sc_mcbo
Balangir, OR (21) 767001, IN

S.No	Item Description	HSN/SAC	Qty UoM	Price (₹)	Taxable Value (₹)	CGST (₹)	SGST (₹)	Amount (₹)
1	PACE1000 Speed Upto 25 Mbps Validity: 30 Days	998422	1	847.50	847.50	76.28 9%	76.28 9%	1,000.06
2	PACE1000 Speed Upto 25 Mbps Validity: 30 Days	998422	1	847.50	847.50	76.28 9%	76.28 9%	1,000.06
3	PACE1000 Speed Upto 25 Mbps Validity: 30 Days	998422	1	847.50	847.50	76.28 9%	76.28 9%	1,000.06
4	PACE1000 Speed Upto 25 Mbps Validity: 30 Days	998422	1	847.50	847.50	76.28 9%	76.28 9%	1,000.06
5	PACE1000 Speed Upto 25 Mbps Validity: 30 Days	998422	1	847.50	847.50	76.28 9%	76.28 9%	1,000.06
5 Total @18%					4,237.50	381.40	381.40	5,000.30

Bank Name: HDFC BANK
Account Number: 50200041046621
Branch Name: HDFC BALANGIR
Code: HDFC0002693

Total Taxable Value ₹4,237.50
Rounded Off (-) ₹0.30
Total Value (in figure) ₹5,000
Total Value (in words) ₹ Five Thousand Only

Terms & Conditions

Bill For Month Of February-2022

MINET COMMUNICATION
Prasenjit Nayak
PROPRIETOR

Prasenjit Nayak

पावर ग्रिड कारपोरेशन ऑफ इंडिया लिमिटेड

(भारत सरकार का उद्यम)

POWER GRID CORPORATION OF INDIA LIMITED

(A Government of India Enterprise)



प्लॉट नं.- 4, युनिट - 41, निलाद्री विहार, चन्द्रसेखरपुर - 751021

दूरभाष : 0674 - 2720754

Plot. No. 4, Unit - 41, Niladri Vihar, Chandrasekharpur,
Bhubaneswar-751021, Tel: 0674-2720754

सन्दर्भ : पाँवरटेल/ भुवनेश्वर/Centurion / बीजक -1

दिनांक: 04.05.2020

To

Centurion School of Rural Enterprise Management Trust
136 & 137, Ramachandrapur, Jatni
Bhubaneswar, Odisha - 751 050

Sub: Submission of Invoices for release of payment

PO Ref: CUTM/CENTRAL STORE/PO/2019-20/953 dated.26.11.19

श्रीमान/ Dear Sir,

कृपया संलग्न बीजक का अवलोकन करें जो की पावर ग्रिड द्वारा आपको प्रदान की गयी दूरसंचार सेवाओं के सम्बन्ध में है. आपसे अनुरोध है की संलग्न बीजको का भुगतान शीघ्र करें .

Please find enclosed herewith the invoices for the period from 04.01.2020 to 31.03.2020 towards the 1 Gbps internet lease line services provided by POWERGRID.

You are kindly requested to release the payment preferably through NEFT/RTGS to the POWEWRGRID Account mentioned in the invoice.

आपको उत्कृष्ट सेवा प्रदान करने के लिए सदा तत्पर. Assuring you of our best services always.

Thanking You,

भवदीय / Yours faithfully,

C.P. 2
3/5

Manas Tiriya
3/5

मानस तिरिया/ Manas Tiriya
उप महाप्रबंधक (दूरसंचार)/ DGM (Telecom) .
पावरग्रिड, ओडिशा परियोजनाएं, भुवनेश्वर
POWERGRID, Odisha Projects, BBSR

04.05.2020

मानस तिरिया / Manas Tiriya

उप मप्र (दूरसंचार) / DGM(Telecom)



पावर ग्रिड कारपोरेशन ऑफ इंडिया लिमिटेड

बिजनेस एंटरप्राइज

POWER GRID CORPORATION OF INDIA LIMITED

(A Government of India Enterprise)



Power Grid Corporation of India Limited
PLOT NO - 4, NILADRI BIHAR, UNIT - 41, CHANDRASEKHARPUR, KHORDHA, BHUBANESWAR, 751021, IN

GSTIN: 21AAACP0252G1Z5
Tax Invoice for TELECOM SERVICES
PAN: AAACP0252G

PGCIL CP : 13676
Customer ID : 0002131409
Type of Service : ISP
Serial No: : 0993044290

Invoice No : E12112200074
Invoice Date : 01.04.2020
Due Date : 16.04.2020

Bill to		Place of Supply	
Name	Centurion School of Rural Enterprise Management Trust	Name	Centurion School of Rural Enterprise Management Trust
Address	136 & 137, RAMACHANDRAPUR, CENTURION SCHOOL OF RURAL ENTERPRISE MANAGEMENT TRUST ODISHA, JATNI, KHURDA,, BHUBANESWAR, 751050, IN	Address	136 & 137, RAMACHANDRAPUR, CENTURION SCHOOL OF RURAL ENTERPRISE MANAGEMENT TRUST ODISHA, JATNI, KHURDA,, BHUBANESWAR, 751050, IN
Customer PO Number	CUTM/CENTRAL STORE/PO/2019-20/953	State/Union Territory	Odisha (Orissa)
Customer PO Date	26.11.2019	State/Union Territory Code	21
PO Value	2360000.00	Customer Code	0002131409
		Customer GSTIN/UIN	21AAATC9278Q1Z5

Link From:	CENTURION SCHOOL OF RURAL	ST/UT	ODISHA (ORISSA)	Link To:	CENTURION SCHOOL OF RURAL ENTERPRISE	ST/UT	ODISHA (ORISSA)
DOCO:	04.01.2020	Capacity:	1.000 GBPS	Billing From	04.01.2020	Billing To	31.03.2020

S.N.	Description of service	HSN/SAC	Gross Value	Discount, If Any	Abatement if any	Taxable value	CGST		SGST / UTGST		IGST	
							Rate	Amount	Rate	Amount	Rate	Amount
1	INTERNET BANDWIDTH CHARGES	998422	4,83,516.00	-	-	4,83,516.00	9.00	43,516.00	9.00	43,516.00	0.00	0.00
	Total		4,83,516.00			4,83,516.00	0.00	43,516.00	0.00	43,516.00	0.00	0.00

Total Invoice value(In figures)(incl GST)	5,70,548.00
Total Invoice value(In Words)(incl GST)	Rupees Five Lakh Seventy Thousand Five Hundred Forty Eight Only
GST Amount(In Figures)	87,032.00
GST amount(In Words)	Rupees Eighty Seven Thousand Thirty Two Only
Whether reverse Charge applicable	NO

E & OE	For & on behalf of Power Grid Corporation of India Limited
Bank details for payment:	Power Grid Corporation of India Limited
MFC Code	ICIC0000106
Name of the Bank & Branch	ICICI Bank Limited, DLF Phase I, Gurgaon Branch
Account Number	POWERG2131409
Account Name	Current Account

Signature & Stamp

मानस तिरिया/ Manas Tiriya
उप महाप्रबंधक (दूरसंचार)/ DGM (Telecom)
पावरग्रिड, ओडिशा परियोजनाएं, भुवनेश्वर
POWERGRID, Odisha Projects, BBSR

Declaration
Certified that the particulars given above are true and correct.

Remarks
1. Payment to be made before the due date in the form of Demand Draft Payable at Delhi in favour of M/s. Power Grid Corporation of India Limited. Alternatively, Payment can be made through NEFT/RTGS as per details above.
2. Delay in payment shall be liable to attract an interest @10% per annum or any other agreed rate. The same shall accrue from due date until such amount is paid in full. The amount of interest shall be addressed in the subsequent bills.
3. Payment details of this bill along with deductions, if any, must be intimated through email address telecom-marketing@powergrid.co.in.

Registered Office: B-9, Qutab Institutional Area, Katwaria Sarai, New Delhi-110016

Customer Acceptance Document

(I-OR-GRNI-ENT-0001)

1. Organization Name: Jagannath Inst For Tech & Mgmt
2. Site Address: Khata No 151/448, Aluri Nagar R. SitapurJitm Campus Gajapati, 761200, Parlakhemundi, Gajapati
3. Circuit id: ILL_9120052089_300635744595
4. ORN :- E00000006WJG
5. Services: Internet Leased Line (ILL)
6. Customer Contact Details:

Sr No	Name	email id	Contact Number
1	SANDIPAN PINE	SANDIPAN@CUTM-AC.IN	7978815760
2			8895308800
3			

7. Service details:

Sr No	Parameters	Details
1	Circuit id	ILL_9120052089_300635744595
2	Circuit Bandwidth (Mbps / Gbps)	1000Mbps
3	Media (Fiber / UBR / FTTx)	Fiber
4	WAN IP Address with subnet mask	136.232.105.128/30
5	LAN IP Address with subnet mask	115.240.99.48/29
6	Gateway IP Address	
7	Routing Protocol	
8	AS Number in case of BGP	
9	Port Type (Electrical / Optical)	Electrical
10	Customer facing Port Number	

8. Jio provided Inventory / Equipment details at site:

Sr No	Make & Model Number of Equipment	Serial Number	Quantity
1	UBR L2 SWITCH		01
2			
3			

9. Test Chart for Service parameter(s):

Sr No	Test Parameter	UoM	Committed	Observed
1	Latency	ms		7ms
1a	Mumbai to London	ms		

1b	Mumbai to New York	ms		
1c	Chennai to Los Angeles	ms		
1d	Chennai to Singapore	ms		
1e	Mumbai to Chennai	ms		
2	Packet Loss	%	0%	0%
3	Jitter (as applicable)	ms		
4	Bandwidth	Mbps / Gbps	1000 Mbps	
5	RFC 2544	RFC 2544 Report		

10. Last mile network connectivity diagram

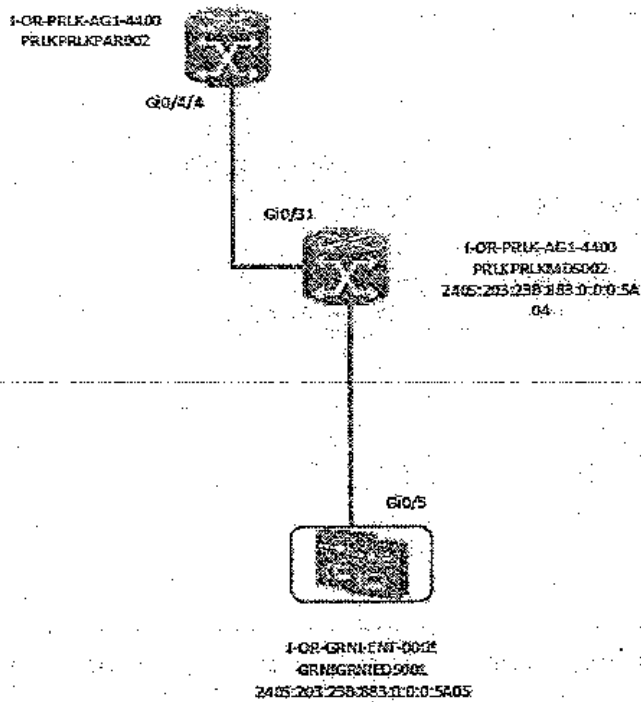

DNS :- 49.45.0.1

For Reliance Jio Infocomm Limited (RJIL)

Name: BISWA BIJAY BISWAL

Signature: B. Biswal

Date: 19/03/2020



Customer Acknowledgement

I hereby acknowledge that I have tested the said link and associated services bearing Circuit id # **ILL_9120052089_300635744595** and certify that the services are satisfactory and as per design / order.

Basis the above, I hereby authorize Reliance Jio Infocomm Limited (RJIL) to initiate services and billing effective date DD/MM/YYYY

Name: SANDEPAN PINE

Signature: Sandipan pine

Date: ~~24-02-2020~~ 19/03/2020

Company Seal

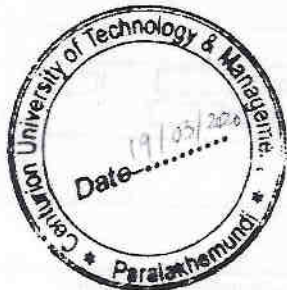

Customer Information (As per Jio Records)	
1	Name of Customer / Organization Jagannath Inst For Tech &Mgmt
2	Logical Circuit ID's (if required Annexure can be used) ILL_9120052089_300635744595
3	Date of Commissioning of Link (In case of up-gradation, mention date of initial commissioning and date of last up gradation)
4	Service Type ILL <input type="checkbox"/> Bandwidth: 1000Mbps
	IP Address (in case of ILL) Dynamic <input type="checkbox"/> Static <input checked="" type="checkbox"/> In case of Static mention Static IP allocated: LAN POOL :- 115.240.99.48/29 WAN POOL :- 136.232.105.128/30
5	Installation Address *The address should be the same as provided at the time of installation Khata No 151/448,Aiuri Nagar R SitapurJitm Campus Gajapati,761200,Parlakhemundi,Gajapati
6	Account Manager Name and Contact Details SANDIPAN PINE, MOB-7978815760 Sandiper@cutm.ac.in
7	Date of Inspection 19/03/2020
8	Type of Inspection First <input checked="" type="checkbox"/> Periodic <input type="checkbox"/>
PHYSICAL INSPECTION OBSERVATIONS	
1	Contact Person Name Name: ANIL KUMAR PATRO Designation: SYSTEM MAINTAINANCE INCHARGE
2	Contact Details ANIL KUMAR PATRO, 9861853499 Email ID - ANIL.PATRO@CUTM.AC.IN
	Name:
	Mobile Number:
	Email id:
3 (a)	OSP Registration Number & Date (if applicable) OSP (Other Service Provide <input type="checkbox"/> Telemarkete <input type="checkbox"/> Othe <input type="checkbox"/>
3 (b)	ISP License Number and Date (if applicable)
3 (c)	Telemarketer Registration Number and Date (if applicable)
4	Whether the connection is used for Application Services like Telemedicine/Telebanking/Tele-Education/Tele-Trading/E-Commerce/Call Centre/Network Operating Centre/Vehicle tracking System/Long Range Alarm/Bill Payment Terminal etc. Yes <input type="checkbox"/> <input checked="" type="checkbox"/>

B. Biswal
19/03/2020

Signature and code of the verifying Person
of the verifying agency

(Authorized Person from Jio)



Declaration/Undertaking from applicant/Client

I/We hereby declare and confirm that

1. I/We are using the connection as per attached network diagram for bonafide usage and for the purpose declared by me/us at the time of subscribing to these connections and these connections are not interconnected with any PSTN, PLMN, GMPCS network.. I/We are not indulged in any unauthorized activities/usage or provision of any services which require prior licensing or permission from designated authorities.
2. I/We have intimated to the Licensor (Copy to respective TERM Cell) in a quarterly report the details of ISP nodes or points of presence with their locations and number of broadband/leased/dialup subscriber.(only in case of ISP customer)
3. I/We have given to the Licensor one month prior notice (Copy to respective term Cell) as required as per terms and condition of ISP License agreement in case new nodes to be installed.(only in case of ISP customer)

Sandipan pine

Signature of authorized person & Company Seal/Stamp

19/03/2020

Date

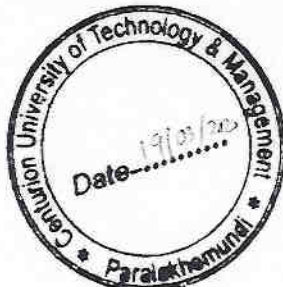

Note:

- I. Network Diagram should be collected from the customer or should be drawn by the verification agent as per the observations.
- II. In case of OSP customer, approved network diagram by TERM Cell should be collected.

Note :-Customer Internal network beyond handover server has not been shared by customer.

For Jio Use Only:

1	Name of Customer	Jagannath Inst For Tech &Mgmt
2	Circuit ID	ILL_9120052089_300635744595
3	Date of Inspection	
4	Network Diagram Verified & Updated	Yes <input checked="" type="checkbox"/> No <input type="checkbox"/>
5	Whether the installation address is Matching with Jio records?	Yes <input checked="" type="checkbox"/> No <input type="checkbox"/>
6		
7	Name of the verification agency (wherever applicable)	N/A
8	Name of executive carrying out Verification.	
9	Remarks/Any other observation found at site	N/A
10	Result of Verification	Positive <input checked="" type="checkbox"/> Negative <input type="checkbox"/>

Note:

- I. In case of any suspicion about the nature of the business carried out/observed, the same has to be brought to the knowledge of concerned Account Manager and CS team on immediate basis.
- II. Any Additional documents collected at the time of physical inspection must be handed over to the JC Onboarding team for records.

B. Biswal

Signature of the verifying person
19/03/2020
verifying agency

(Authorized Person form Jio)



