



GRAM TARANG FOODS
PRIVATE LIMITED

CIN: U15549AP2009PTC064398
FY 2017-18



B-107, KSR Green Valley,
Madhavadhara, Visakhapatnam
Andhra Pradesh

GRAM TARANG FOODS PRIVATE LIMITED
NINTH ANNUAL REPORT
2017-18

BOARD OF DIRECTORS

Shashikant Tewary	-	Managing Director
D.N.Rao	-	Director

REGISTERED OFFICE

D-206, KSR Green Valley,
Madhavadhara, Visakhapatnam
Andhra Pradesh.

BANKERS

Andhra Bank

AUDITORS

SPC&Associates
Chartered Accountants

CONTENTS

- A G M Notice
- Directors' Report
- Auditors' Report
- Balance Sheet and Statement of Profit & Loss
- Notes forming part of Balance Sheet and Statement of Profit & Loss

NOTICE – SHAREHOLDERS
NINTH ANNUAL GENERAL MEETING

AGM Date	29 th September, 2018
Time	10.30 A.M.
Venue	Registered Office of the Company
	D-107, KSR Green Valley, Madhavadhara, Visakhapatnam Andhra Pradesh

ORDINARY BUSINESS:

1. To receive, consider and adopt the accounts of the company for the year ended 31st March, 2018 and the reports of the Directors and Auditors thereon.
2. To consider and if thought fit to pass the following resolution with or without modification as an ordinary resolution.

“RESOLVED THAT pursuant to the provision of section 139, 142 and other applicable provisions, if any, of the Companies Act, 2013 read with the underlying rules viz. Companies (Audit and auditors) Rules, 2014 as may be applicable and pursuant to the resolution passed by the members in the Annual General Meeting held on 29th September, 2018, the appointment of SPC & Associates, Chartered Accountants (FRN:005685S) as the auditors of the Company to hold office till the conclusion of the next AGM be and is hereby ratified and that the Board be and hereby authorized to fix the remuneration payable to them for the financial year ending March 31, 2019”

NOTES:

1. A member entitled to attend and vote at the meeting is also entitled to appoint a proxy to attend and vote instead of himself. A proxy need not be a member.
2. The proxy form duly completed and signed should be deposited at the Registered Office of the Company at least 48 hours before the commencement of the meeting.
3. Members are requested to notify immediately change of address, if any, to the Company’s registered office quoting their Registered Folio Number.

By Order of the Board

For GRAM TARANG FOODS PRIVATE LIMITED



Shashikant Tewary
Director (DIN: 06453360)

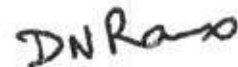

D.N.Rao
Director(DIN: 00939956)

Place: Vishakhapatnam
Date: 17th August, 2018

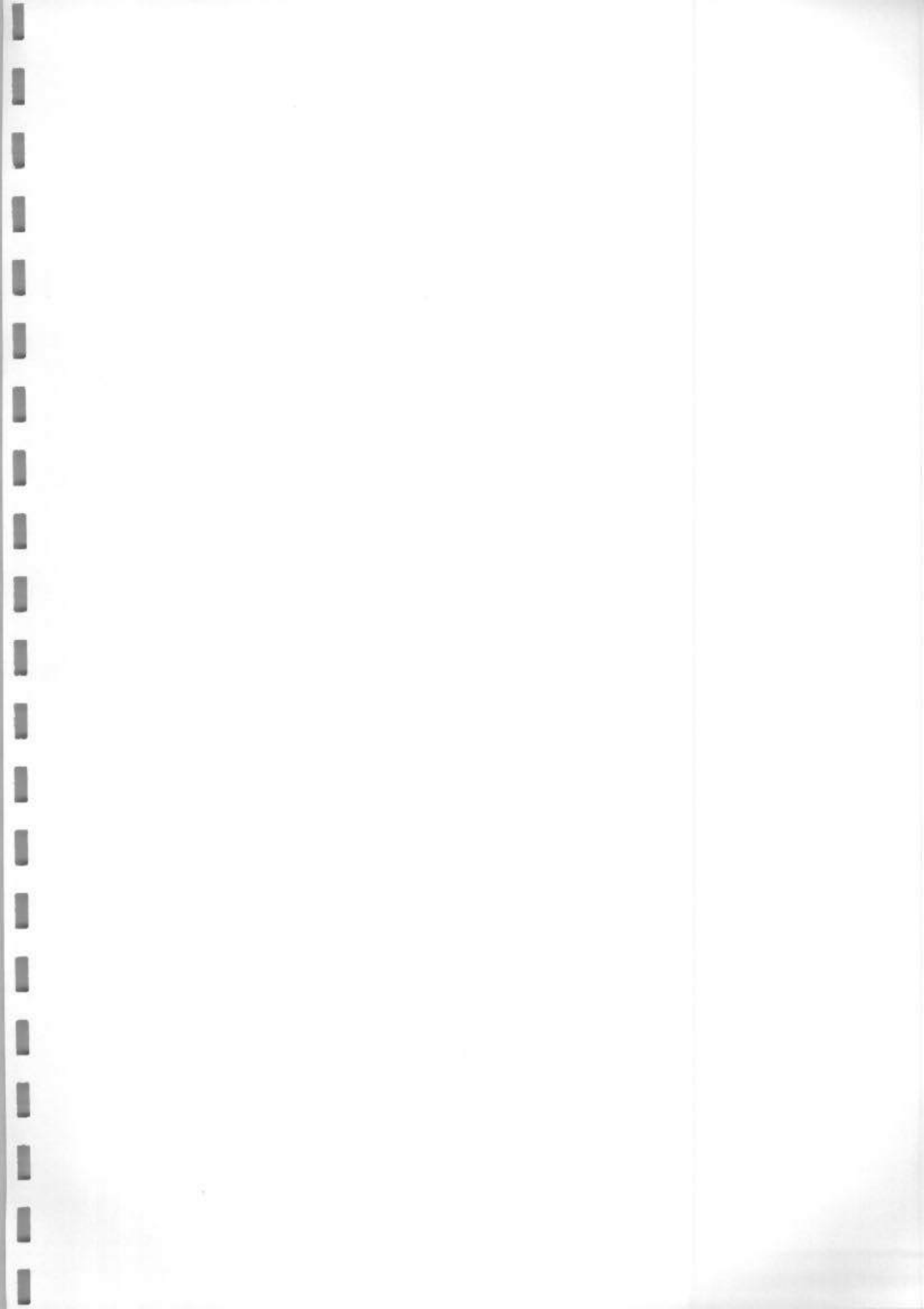

DIRECTORS' REPORT

To

**The Members,
Gram Tarang Foods Private Limited**

Your directors have pleasure in presenting their Ninth Annual Report on the business and operations of the company together with the Audited Statement of Accounts for the year ended 31st March, 2018.

A. Financial Highlights

During the year under review, performance of the company is as under:

(Amount in `)

Particulars	Year ended 31st March 2018	Year ended 31st March 2017
Total Income	1,70,10,746	1,58,92,177
Profit/(Loss) before taxation	17,84,570	31,25,088
<i>Less</i> : Tax Expense		
Current Tax :	33,052	5,95,458
Deferred Tax(Asset)/Liability :	(1,36,954)	(2,46,599)
Profit/(Loss) after tax	19,06,787	27,76,202
<i>Add</i> : Balance B/F from the previous year	(1,66,56,098)	(2,00,27,785)
Balance Profit / (Loss) C/F to the next year	(1,47,49,311)	(1,66,56,098)

B. State of Company's Affairs and Future Outlook

The Company deals in the business of manufacturing and processing of food products. However, due to lack of market potential, it has been incurring losses.

C. Change in nature of business, if any

There is no change in the nature of business of the company.

D. Dividend

The directors of the company have not recommended any dividend for the year ended 31st March, 2018.

E. Amounts Transferred to Reserves

There are no transfers made to the reserves during the year.

F. Changes in Share Capital, if any

There is no change in share capital during the year.

Disclosure regarding Issue of Equity Shares with Differential Rights

Not Applicable.

Disclosure regarding issue of Employee Stock Options

Not Applicable.

Disclosure regarding issue of Sweat Equity Shares

Not Applicable.

G. Extract of Annual Return

The extract of Annual Return, in format MGT-9, for the Financial Year 2017-18 has been enclosed with this report.

H. Number of Board Meetings

During the Financial Year 2017-18, 4 meetings of the Board of Directors of the company were held.

Particulars	Date of the Board meeting
Review the Financial Performance	16 th June, 2017
Approval of Financials of FY 2016-17	30 th August, 2017
Review the Business Operations	26 th November, 2017
Review the Financial Performance	12 th February, 2018

I. Particulars of Loan, Guarantees and Investments under Section 186

The Company does not have any loans, guarantees and investments covered under section 186 of the Companies Act, 2013.

J. Particulars of Contracts or Arrangements with Related Parties

The particulars referred above as per section 188 of the Act in accordance with the Rule 8 of the Companies (Accounts) Rules, 2014 is attached to this report.

K. Explanation to Auditor's Remarks

The Auditors' Report to the Members does not contain any qualifications, reservations or adverse remarks.

L. Material Changes Affecting the Financial Position of the Company

There are no material changes and commitments, affecting the financial position of the Company between the end of the financial year and the date of this report.

M. Conservation of Energy, Technology, Absorption, Foreign Exchange Earnings and Outgo

a) Conservation of Energy : N.A.

b) Technology Absorption

A) Research and Development (R&D) : Nil

B) Technology Absorption and Innovation : Nil

c) Foreign Exchange Earnings and Out go

Earnings : Nil

Out go : Nil

N. Details of Subsidiary, Joint Venture or Associates

During the year, no companies have become or ceased to be its subsidiaries, joint ventures or associate companies

O. Risk Management Policy

The board has not identified any such risk which may threaten the existence of the company.

P. Details of Directors and Key Managerial Personnel

No Directors have been appointed or resigned during the year.

Q. Details of significant & material orders passed by the regulators or courts or tribunal

There are no such orders passed during the current financial years.

R. Voluntary Revision of Financial Statements or Board's Report

No voluntary revision of Financial Statements or Board's Report in respect of any of the 3 preceding financial years has been made.

S. Re-appointment of Independent Auditor

Pursuant to Section 139 and other applicable provisions, if any, of the Companies Act, 2013, SPC&Associates, Chartered Accountants, are proposed to be ratified as the Statutory Auditors in the ensuing Annual General Meeting.

T. Disclosures under Sexual Harassment of Women at Workplace (Prevention, Prohibition & Redressal) Act, 2013

There are no such cases filed during the Financial Year.

U. Fraud Reporting (Required by Companies Amendment Bill, 2014)

The board has not identified any frauds.

V. Statutory Auditors

Pursuant to Section 139 and other applicable provisions, if any, of the Companies Act, 2013, SPC&Associates, Chartered Accountants, are proposed to be re-appointed as the Statutory Auditors in the ensuing Annual General Meeting.

W. Directors Responsibility Statement

In accordance with the provisions of Section 134(5) of the Companies Act 2013, your directors confirm that:

- a) in the preparation of the annual accounts for the financial year ended 31st March, 2018, the applicable accounting standards had been followed along with proper explanation relating to material departures;
- b) the directors had selected such accounting policies and applied them consistently and made judgments and estimates that are reasonable and prudent so as to give a true and fair view of the state of affairs of the Company as at 31st March, 2018 and of the profit of the Company for that period;

c) the directors had taken proper and sufficient care for the maintenance of adequate accounting records in accordance with the provisions of the Companies Act 2013 for safeguarding the assets of the company and for preventing and detecting fraud and other irregularities;

d) the directors had prepared the annual accounts on a going concern basis;

e) the directors had devised proper systems to ensure compliance with the provisions of all applicable laws and that such systems were adequate and operating effectively.

X. Acknowledgment

The Directors express their sincere appreciation to the valued shareholders, bankers and clients for their support.

For and on behalf of the Board of Directors
Gram Tarang Foods Private Limited



Shashikant Tewary
Managing Director (DIN: 06453360)

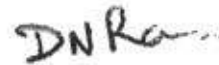

D.N.Rao
Director (DIN: 00939956)

Place: Vishakhapatnam
Date: 17th August, 2018

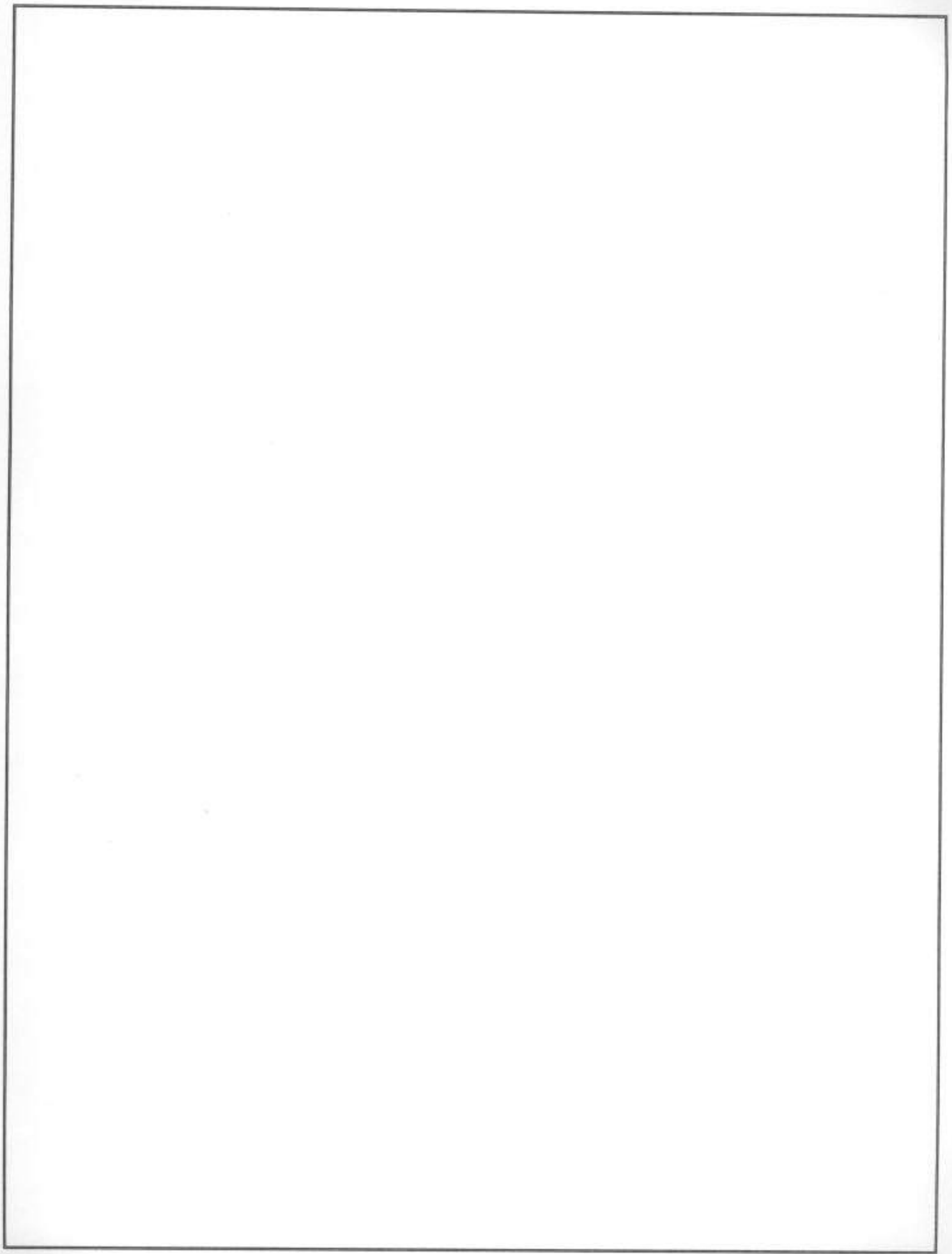

NOTES TO ACCOUNTS

NOTE: 28

SIGNIFICANT ACCOUNTING POLICIES:

A. Basis of Accounting

The accounts of the company are prepared & maintained consistently on accrual basis and under the historic cost convention and in accordance with the generally accepted accounting principles in India and in compliance with the applicable Accounting Standards issued by the Institute of Chartered Accountants of India as per Section 133 and relevant provisions of the Companies Act, 2013, except otherwise stated.

All assets and liabilities have been classified as current or non-current as per the Company's normal operating cycle and other criteria set out in the Schedule III to the Companies Act, 2013.

B. Fixed Assets

Fixed Assets are stated at cost (cost includes acquisition cost, freight, installation cost, finance cost, duties and taxes and other incidental expenses incurred during the construction/installation).

C. Depreciation

Depreciation on Fixed Assets is provided on the Written Down Value Method, as per the useful life of the assets given in the Schedule II to the Companies Act, 2013; and in the opinion of the management these rates reflect the estimated useful life of those assets. The Company estimates the scrap value of the assets to be 5% of the cost.

D. Revenue Recognition

Income is accounted for on the basis of products sold and billed to customers.

E. Earnings per share:

Basic earnings per share is computed by dividing the profit/ (loss) after tax (including the post-tax effect of extraordinary items, if any) by the weighted average number of equity shares outstanding during the year.

F. Provisions and Contingencies

A provision is recognized when the Company has a present obligation as a result of past events and it is probable that an outflow of resources will be required to settle the obligation in respect of which a reliable estimate can be made. Provisions are not discounted to their present value and are determined based on the best estimate required to settle the obligation at the Balance Sheet

date. These are reviewed at each Balance Sheet date and adjusted to reflect the current best estimates. Contingent liabilities are disclosed in the Notes.

G. Income Tax

The Company provides for and determines the current tax as the amount of tax payable in respect of the total income for the period. The Company recognizes and provides for the deferred tax on timing differences between total income and accounting income subject to the concept of prudence.

H. Cash and Cash equivalents

Cash comprises cash on hand and demand deposits with banks. Cash equivalents are short-term balances (with an original maturity of three months or less from the date of acquisition), highly liquid investments that are readily convertible into known amounts of cash and which are subject to insignificant risk of changes in value.

For SPC&Associates
Chartered Accountants
FRN: 005685S

for and on behalf of Board of Directors
GRAM TARANG FOODS PRIVATE LIMITED



CA Shravan kumar Reddy
Partner
MRN: 241004



Shashikant Tewary
Managing Director
(DIN: 06453360)



D.N.Rao
Director
(DIN: 00939956)

Date: 17th August, 2018
Place: Vishakhapatnam

Form No. AOC-2

(Pursuant to clause (b) of sub-section (3) of section 134 of the Act and Rule 8(2) of the Companies (Accounts) Rules, 2014)

Form for disclosure of particulars of contracts/arrangements entered into by the company with related parties referred to in sub-section (1) of section 188 of the Companies Act, 2013 including certain arm's length transactions under third proviso thereto.

1. Details of contracts or arrangements or transactions not at arm's length basis

(a) Name(s) of the related party and nature of relationship	Not Applicable
(b) Nature of contracts/ arrangements/ transactions	
(c) Duration of the contracts / arrangements/transactions	
(d) Salient terms of the contracts or arrangements or transactions including the value, if any	
(e) Justification for entering into such contracts or arrangements or transactions	
(f) Date(s) of approval by the Board	
(g) Amount paid as advances, if any:	
(h) Date on which the special resolution was passed in general meeting as required under first proviso to section 188	

2. Details of material contracts or arrangement or transactions at arm's length basis

(a) Name(s) of the related party and nature of relationship	Not Applicable
(b) Nature of contracts/ arrangements/ transactions	
(c) Duration of the contracts / arrangements/transactions	
(d) Salient terms of the contracts or arrangements or transactions including the value, if any	
(e) Date(s) of approval by the Board	
(f) Amount paid as advances, if any:	

GRAM TARANG FOODS PRIVATE LIMITED

CIN :U15549AP2009PTC064398

BALANCE SHEET AS AT 31st March, 2018

Particulars	Note No.	Amount in ₹	
		Figures at the end of	
		31-Mar-18	31-Mar-17
I. EQUITY AND LIABILITIES			
(1) Shareholder's Funds			
(a) Share Capital	1	52,50,000	52,50,000
(b) Reserves and Surplus	2	(1,24,99,312)	(1,44,06,099)
(2) Non-Current Liabilities			
(a) Long-Term Borrowings	3	1,95,00,250	2,38,79,175
(b) Deferred Tax Liabilities (Net)	4	(1,44,494)	(7,540)
(3) Current Liabilities			
(a) Short-Term Borrowings			
(b) Trade Payables	5	42,49,289	22,05,243
(c) Other Current Liabilities	6	1,17,90,683	1,36,88,843
(d) Short-Term Provisions	7	51,952	6,36,885
Total Equity & Liabilities		2,81,98,368	3,12,46,507
II.ASSETS			
(1) Non-Current Assets			
(a) Fixed Assets			
(i) Tangible Assets	8	1,87,78,381	2,24,26,802
(ii) Intangible Assets		5,48,388	7,59,652
(b) Long term loans and advances	9	1,93,26,770	2,31,86,455
		9,22,166	9,03,850
(2) Current Assets			
(a) Inventories	10	43,46,962	36,77,125
(b) Trade receivables	11	27,60,820	21,32,105
(c) Cash and cash equivalents	12	2,45,754	1,10,553
(d) Short-term loans and advances	13	5,95,897	12,36,420
Total Assets		2,81,98,368	3,12,46,507
Accounting Policies and other Notes to Accounts	24-30		

As per our report of even date attached.

For SPC&Associates

Chartered Accountants

FRN : 005685S

CA Shrvan Kumar Reddy

Partner

MRN:240014

Place: Vishakhapatnam

Date: 17-08-2018

GRAM TARANG FOODS PRIVATE LIMITED

Shashikant Tewary
Managing Director
DIN : 6453360

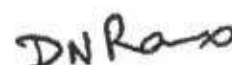
D.N.Rao
Director
DIN: 00939956

GRAM TARANG FOODS PRIVATE LIMITED
CIN :U15549AP2009PTC064398
PROFIT & LOSS STATEMENT FOR THE YEAR ENDED ON 31st March, 2018

Sr. No	Particulars	Note No.	Amount in ₹	
			Figures for the year ended	
			31-Mar-18	31-Mar-17
I	Revenue from operations	14	1,58,70,554	98,47,690
II	Other Income	15	11,40,192	60,44,487
	III. Total Revenue (I +II)		1,70,10,746	1,58,92,177
IV	Expenses:			
	Cost of materials consumed	16	53,83,650	55,72,652
	Changes in inventories of finished goods, work-in-progress and Stock-in-Trade	17	(5,44,074)	(25,28,883)
	Employee Benefit Expense	18	13,57,930	7,79,204
	Financial Costs	19	11,03,539	23,84,378
	Depreciation and Amortization Expense	20	38,65,131	47,21,132
	Other Administrative Expenses	21	40,60,000	18,38,607
	Total Expenses (IV)		1,52,26,176	1,27,67,089
V	Profit/(Loss) before exceptional and extraordinary items and tax	(III - IV)	17,84,570	31,25,088
VI	Exceptional Items		-	-
VII	Profit/(Loss) before extraordinary items and tax (V - VI)		17,84,570	31,25,088
VIII	Extraordinary Items		-	-
IX	Profit / (Loss) before tax (VII - VIII)		17,84,570	31,25,088
X	Tax expense:			
	(1) Current tax		33,052	5,95,485
	(2) Deferred tax		(1,36,954)	(2,46,599)
	(3) MAT Credit		(18,316)	(5,95,485)
XI	Profit/(Loss) from the period from continuing operations	(IX-X)	19,06,787	33,71,687
XII	Profit/(Loss) from discontinuing operations		-	-
XIII	Tax expense of discounting operations		-	-
XIV	Profit/(Loss) from Discontinuing operations (XII - XIII)		-	-
XV	Profit/(Loss) for the period (XI + XIV)		19,06,787	33,71,687
XVI	Earning per equity share:	22		
	(1) Basic		3.63	(10.27)
	(2) Diluted		3.63	(10.27)
Accounting Policies and other Notes to Accounts		24-30		

As per our report of even date attached.

For SPC&Associates
Chartered Accountants

FRN : 0056855

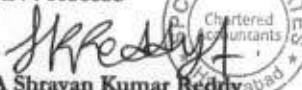
CA Shravan Kumar Reddy

Partner

MRN:240014

Place: Vishakhapatnam

Date: 17-08-2018

GRAM TARANG FOODS PRIVATE LIMITED

Shashikant Tewary
Managing Director
DIN : 6453360

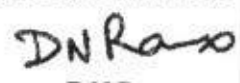

D.N.Rao
Director
DIN: 00939956

GRAM TARANG FOODS PRIVATE LIMITED
CIN :U15549AP2009PTC064398
CASH FLOW STATEMENT FOR THE YEAR ENDED 31.03.2018

Particulars	31-Mar-18	31-Mar-17
Cash Flow from Operating Activities		
Net Profit before Taxation and extraordinary items	17,84,570	31,25,088
Adjustments for:		
Depreciation and Amortisation	38,65,131	47,21,132
Interest debited to P&L	10,91,814	23,61,378
Operating Profit before Working Capital Changes	67,41,514	1,02,07,598
Working Capital Changes		
(Increase)/Decrease in Current Assets		
(Increase)/Decrease in Short term loans and advances	6,40,523	(10,17,200)
(Increase)/Decrease in Inventories	(6,69,837)	(20,86,735)
(Increase)/ Decrease in Trade Receivables	(6,28,715)	(16,91,188)
(Increase)/ Decrease in Other Current Assets	-	-
(Increase)/Decrease in Current Liabilities		
Increase/(Decrease) in Short Term Borrowings	-	(50,53,065)
Increase/ (Decrease) in Provisions	(6,17,985)	6,04,475
Increase/ (Decrease) in Other Current Liabilities	(18,98,160)	1,05,12,524
Increase/ (Decrease) in Trade Payables	20,44,046	(43,03,937)
Cash generated from operations	56,11,386	71,72,472
Net Cash Flow from Operating Activities	56,11,386	71,72,472
Cash Flow from Investing activities		
Purchase of Fixed Assets	(5,446)	-
(Increase)/ Decrease in Long term loans and advances	(18,316)	(5,95,485)
Net Cash Flow from Investing Activities	(23,762)	(5,95,485)
Cash Flow from Financing activities		
Increase in Share Capital	-	-
Security Premium received	-	-
Share Application money received	-	-
Decrease in long term borrowings	(43,60,609)	(43,37,683)
Interest Debited to P&L a/c	(10,91,814)	(23,61,378)
Net Cash Flow from Financing Activities	(54,52,423)	(66,99,061)
Net Increase or decrease in cash and cash equivalents	1,35,201	(1,22,075)
Increase or decrease in cash and cash equivalents	1,35,202	(1,22,074)
Add: Cash and cash equivalents at the beginning of the period	1,10,553	2,32,627
Cash and cash equivalents at the end of the period	2,45,754	1,10,553

As per our report of even date attached.

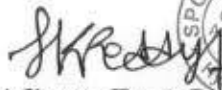
For SPC&Associates
Chartered Accountants
FRN : 005685S

CA Shravan Kumar Reddy
Partner
MRN:240014

Place: Vishakhapatnam
Date: 17-08-2018

For GRAM TARANG FOODS
PRIVATE LIMITED

Shashikant Tewary
Managing Director
DIN : 6453360

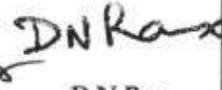
D.N.Rao
Director
DIN: 00939956

GRAM TARANG FOODS PRIVATE LIMITED
Notes Forming Integral Part of Financial Statements

Note: 1 Share Capital

S.No	Particulars	Amount in ₹	
		31-Mar-18	31-Mar-17
1	AUTHORIZED CAPITAL 10,00,00 Equity Shares of Rs. 10/- each.	1,00,00,000	1,00,00,000
2	ISSUED, SUBSCRIBED & PAID UP CAPITAL 5,25,000 Equity Shares of Rs. 10/- each Fully Paid up	52,50,000	52,50,000
	Total	52,50,000	52,50,000

a) Rights, preferences and restrictions attached to shares:

The company has one class of equity shares having a par value of ₹.10 per share. Each shareholder is eligible for one vote per share held. In the event of liquidation, the equity shareholders are eligible to receive the remaining assets of the Company after distribution of all preferential amounts, in proportion to their shareholding.

b) Details of Shares held by each shareholder holding more than 5% shares:

S.No	Name	Class of Share	Year Ended 31-Mar-18		Year Ended 31-Mar-17	
			No. of Share Holding	% of Holding	No. of Share Holding	% of Holding
1	Mukti Kanra Mishra	Equity shares fully paid up	118334	22.54%	118334	22.54%
2	DN Rao	Equity shares fully paid up	168333	32.06%	168333	32.06%
3	Shashikanth Tewary	Equity shares fully paid up	163333	31.11%	163333	31.11%
4	Supriya Patanaik	Equity shares fully paid up	50000	9.52%	50000	9.52%

c) Reconciliation of the number of shares and amount outstanding at the beginning and at the end of the period:

S.No	Particulars	Equity Shares	
		Year Ended 31-Mar-18	Year Ended 31-Mar-17
		No. of Shares	Amount in ₹
1	Opening Balance	5,25,000	52,50,000
2	Add/Less: Change During the Year	-	-
3	Closing Balance	5,25,000	52,50,000

GRAM TARANG FOODS PRIVATE LIMITED
Notes Forming Integral Part of Financial Statements

Note: 2 Reserve & Surplus

		Amount in ₹	
S No	Particulars	31-Mar-18	31-Mar-17
I	Securities Premium		
1	Premium on issue of shares	22,50,000	22,50,000
	Total(A)	22,50,000	22,50,000
II	Surplus		
1	Opening balance	(1,66,56,098)	(2,00,27,785)
2	Add: Profit / (Loss) for the year	19,06,787	33,71,687
3	Less: Depreciation written off	-	-
	Total(B)	(1,47,49,311)	(1,66,56,098)
	Total	(1,24,99,311)	(1,44,06,098)

Note: 3 Long Term Borrowings

		Amount in ₹	
S No	Particulars	31-Mar-18	31-Mar-17
1	Term Loan from Banks and Financial Institutions		
	From Bank from Andhra Bank	42,87,424	86,66,349
2	Unsecured Loans		
	Loans from Directors and relatives	1,37,12,826	1,37,12,826
3	GTET	-	-
4	GTIDS	15,00,000	15,00,000
	Total	1,95,00,250	2,38,79,175

Note: 4 Deffered Tax Liability (Net)

		Amount in ₹	
S No	Particulars	31-Mar-18	31-Mar-17
1	Deffered Tax Liability		
	Opening Balance	(7,540)	2,39,059
	Add: Current year (Asset)/Liability	(1,36,954)	(2,46,599)
	Total	(1,44,494)	(7,540)

Disclosures:

In accordance with the Accounting Standard (AS-22) on "Accounting for Taxes on Income" issued by the Institute of Chartered Accountants of India, the Company has created deferred Tax Asset arising out of the timing differences between taxable and book profits. Due to lack of reasonable certainty of taxable income in subsequent periods, the Company has not accounted for deferred tax asset arising on account of the timing difference.

GRAM TARANG FOODS PRIVATE LIMITED
Notes Forming Integral Part of Financial Statements

Note: 2 Reserve & Surplus

Amount in ₹

S No	Particulars	31-Mar-18	31-Mar-17
I	Securities Premium		
1	Premium on issue of shares	22,50,000	22,50,000
	Total(A)	22,50,000	22,50,000
II	Surplus		
1	Opening balance	(1,66,56,098)	(2,00,27,785)
2	Add: Profit /(Loss) for the year	19,06,787	33,71,687
3	Less: Depreciation written off	-	-
	Total(B)	(1,47,49,311)	(1,66,56,098)
	Total	(1,24,99,311)	(1,44,06,098)

Note: 3 Long Term Borrowings

Amount in ₹

S No	Particulars	31-Mar-18	31-Mar-17
1	Term Loan from Banks and Financial Institutions		
	From Bank from Andhra Bank	42,87,424	86,66,349
2	Unsecured Loans		
	Loans from Directors and relatives	1,37,12,826	1,37,12,826
3	GTET	-	-
4	GTIDS	15,00,000	15,00,000
	Total	1,95,00,250	2,38,79,175

Note: 4 Deferred Tax Liability (Net)

Amount in ₹

S No	Particulars	31-Mar-18	31-Mar-17
1	Deferred Tax Liability		
	Opening Balance	(7,540)	2,39,059
	Add: Current year (Asset)/Liability	(1,36,954)	(2,46,599)
	Total	(1,44,494)	(7,540)

Disclosures:

In accordance with the Accounting Standard (AS-22) on "Accounting for Taxes on Income" issued by the Institute of Chartered Accountants of India, the Company has created deferred Tax Asset arising out of the timing differences between taxable and book profits. Due to lack of reasonable certainty of taxable income in subsequent periods, the Company has not accounted for deferred tax asset arising on account of the timing difference.

GRAM TARANG FOODS PRIVATE LIMITED
Notes Forming Integral Part of Financial Statements

Note: 5 Trade Payables

Amount in ₹

S No	Particulars	31-Mar-18	31-Mar-17
1	Sundry Creditors	42,49,289	22,05,243
	Total	42,49,289	22,05,243

Note: 6 Other Current Liabilities

Amount in ₹

S No	Particulars	31-Mar-18	31-Mar-17
1	CST Payable	-	88,729
2	GST Payables	73,595	-
3	Service tax payable	-	13,71,428
4	TDS Payable	44,761	22,856
5	Advances	24,75,050	28,42,246
6	Advances to staff	800	-
7	Rent Received in Advance	78,28,572	88,80,001
8	Salary Payable	12,86,586	60,890
9	VAT Payable	0	3,74,831
10	Telephone Charges Payable	1,062	-
11	Electricity charges payable	80,257	47,862
	Total	1,17,90,683	1,36,88,843

Note: 7 Short Term Provisions

Amount in ₹

S No	Particulars	31-Mar-18	31-Mar-17
1	Provision for Income Tax	33,052	5,95,485
2	Audit Fees Payable	18,900	41,400
	Total	51,952	6,36,885

GRAM TARANG FOODS PRIVATE LIMITED
Notes Forming Part of Financial Statements

Note: 8 Fixed Assets

S No	Particulars	Gross Block				Depreciation			Net Block	
		Value at the beginning	Addition during the year	Deduction during the year	Value at the end	Value at the beginning	Addition during the year	Adjustment to Retained Earnings	Value at the end	WDV at the beginning of the year
I	Tangible Assets									
1	Land	2,55,289	-	-	2,55,289	-	-	-	2,55,289	2,55,289
2	Building	92,36,037	-	-	92,36,037	4,77,762	-	-	45,44,381	50,22,143
3	Plant and Machinery	3,80,58,866	-	-	3,80,58,866	31,67,868	-	-	1,39,67,758	1,71,35,626
4	Office Equipment	70,061	5,446	-	75,507	8,237	-	-	9,762	12,553
5	Others									
	Computers & Laptops	72,939	-	-	72,939	-	-	-	1,191	1,191
	SUB TOTAL (A)	4,76,93,192	5,446	-	4,76,98,638	36,53,867	-	-	1,87,78,381	2,24,26,802
II	Intangible Assets									
1	Technical Know How	22,86,863	-	-	22,86,863	2,11,264	-	-	5,48,388	7,59,652
	SUB TOTAL (B)	22,86,863	-	-	22,86,863	2,11,264	-	-	5,48,388	7,59,652
	Total [A + B] (Current Year)	4,99,80,055	5,446	-	4,99,85,501	38,65,131	-	-	1,93,26,770	2,31,86,455

GRAM TARANG FOODS PRIVATE LIMITED
Notes Forming Part of Financial Statements

Note : 9 Long Term Loans and Advances

Amount in ₹

S No	Particulars	31-Mar-18	31-Mar-17
1	Security Deposit Deposit - Sales TAX Dept Security Deposit - Ramsatya Agencies Security Deposit (Electricals)	15,000 50,000 2,43,365	15,000 50,000 2,43,365
2	MAT Credit Entitlement	6,13,801	5,95,485
	Total	9,22,166	9,03,850

Note : 10 Inventories

Amount in ₹

S No	Particulars	31-Mar-18	31-Mar-17
1	Inventories Raw Material	4,76,543	3,50,780
2	Stock in Trade Finished Goods	38,70,419	33,26,345
	Total	43,46,962	36,77,125

Note : 11 Trade Recievables

Amount in ₹

S No	Particulars	31-Mar-18	31-Mar-17
1	Outstanding for more than six months a) Secured, Considered Good : b) Unsecured, Considered Good : c) Doubtful	11,93,057	1,702
2	Other receivables a) Secured, Considered Good : b) Unsecured, Considered Good : c) Doubtful	15,67,763	21,30,403
	Total	27,60,820	21,32,105

Note : 12 Cash & Cash Equivalent

Amount in ₹

S No	Particulars	31-Mar-18	31-Mar-17
A	Balances with Banks With Andhra Bank A/c No. 043811100000186 With Andhra Bank -107411100000964 (Vizag)	2,19,645 4,912	4,092 4,912
	Sub Total (A)	2,24,557	9,004
B	Cash on Hand Cash Balance	21,196	1,01,550
	Sub Total (B)	21,196	1,01,550
	Total [A + B]	2,45,753	1,10,554

Note : 13 Short Term Loans and Advances

Amount in ₹

S No	Particulars	31-Mar-18	31-Mar-17
1	GST Input	1,68,353	
2	Prepaid Insurance	1,08,743	1,17,184
3	Other Advances	-	2,04,950
4	TDS Receivable	-	9,14,286
5	Income Tax Refund Due for AY 2017-18	3,18,801	
	Total	5,95,897	12,36,420

GRAM TARANG FOODS PRIVATE LIMITED
Notes Forming Part of Financial Statements

Note : 14 Revenue from Operations		Amount in ₹	
S No	Particulars	31-Mar-18	31-Mar-17
1	Local Sales and Services	1,37,09,554	32,65,344
2	Inter State Sales	21,61,000	65,82,346
	Total	1,58,70,554	98,47,690

Note : 15 Other Income		Amount in ₹	
S No	Particulars	31-Mar-18	31-Mar-17
1	Ginger Oleoresin	-	-
2	Transport Charges	13,265	27,889
3	Rental Income	10,51,429	2,62,857
4	Interest on Tds	-	133
5	Other Income	45,053	3,703
6	Sundry Creditors written off	-	57,49,905
7	Packing Charges	19,170	-
8	Insurance	11,275	-
	Total	11,40,192	60,44,487

Note : 16 Cost of Material Consumed		Amount in ₹	
S No	Particulars	31-Mar-18	31-Mar-17
1	Opening Stock	3,50,780	7,92,928
	Add: Purchases	50,64,952	50,11,250
	Add: Direct Expenses	4,44,461	1,19,254
		58,60,193	59,23,432
	Less: Closing Stocks	4,76,543	3,50,780
	Total	53,83,650	55,72,652

Note : 17 Changes in Inventories		Amount in ₹	
S No	Particulars	31-Mar-18	31-Mar-17
1	Inventories at the end of the Year		
	Finished Goods	38,70,419	33,26,345
	Total	38,70,419	33,26,345
2	Less: Inventories at the beginning of the Year		
	Finished Goods	33,26,345	7,97,462
	Total	33,26,345	7,97,462
	Net Increase/(Decrease)	5,44,074	25,28,883

Note : 18 Employee Benefit Expenses		Amount in ₹	
S No	Particulars	31-Mar-18	31-Mar-17
1	Salaries	13,22,930	7,78,654
2	Incentive	35,000	550
	Total	13,57,930	7,79,204

GRAM TARANG FOODS PRIVATE LIMITED

Notes Forming Part of Financial Statements

Note : 19 Financial Cost		Amount in ₹	
S No	Particulars	31-Mar-18	31-Mar-17
1	Interest on Term loan	10,91,814	17,41,904
2	Interest on CC	-	6,19,474
3	Processing Charges	-	23,000
4	Inspection Charges (Plant)-Andhra Bank	11,725	-
	Total	11,03,539	23,84,378

Note : 20 Depreciation & Amortised Cost		Amount in ₹	
S No	Particulars	31-Mar-18	31-Mar-17
1	Depreciation	38,65,131	47,21,132
	Total	38,65,131	47,21,132

Note : 21 Other Administrative Expenses		Amount in ₹	
S No	Particulars	31-Mar-18	31-Mar-17
1	Advertisement	27,637	8,631
2	Audit Fees	47,200	46,000
3	Bank Charges	4,409	49,296
4	Consumables for plant	73,077	32,154
5	Consultancy Fees	1,89,239	23,970
6	Commission	12,32,547	4,00,000
7	Electricity Charges	5,59,610	4,37,641
8	Fees and membership	1,55,035	5,000
9	Fooding Exp.	38,985	19,596
10	Insurance	1,43,130	96,013
11	Penal Interest	46,875	8,987
12	Input Service Tax	11,800	-
13	Laboratory Test Charges	34,811	57,005
14	Loading & Unloading Charges	48,526	-
15	Lodging & Boarding and Travelling	1,15,964	803
16	Legal Expenses	-	12,800
17	Office Expenses	46,892	19,422
18	Transportation Charges	5,31,655	2,57,840
19	Postage & Courier Charges	12,364	1,487
20	Printing and Stationery	61,093	14,500
21	Repair & Maintance	5,72,750	1,23,879
22	Telephone Expenses	14,206	9,418
23	Professional Charges	11,800	65,300
24	Rent & Rates and Taxes	72,584	1,42,225
25	Website Expenses	-	6,640
26	Roc Charges	1,200	-
27	Bad debts written off	6,612	-
	Total	40,60,000	18,38,607

GRAM TARANG FOODS PRIVATE LIMITED

Other Notes Forming Integral Part of the Financial Statements as at 31st March, 2018

Note : 22 Earnings Per Share

Amount in ₹

S.No	Particulars	31-Mar-18	31-Mar-17
1	Net Profit for the year	19,06,787	(53,92,661)
2	Net Profit for the year attributable to the equity share holders (A)	19,06,787	(53,92,661)
3	Weighted Average Number of Equity Shares (B)	5,25,000	5,25,000
4	Par Value of Share	10	10
5	Earnings Per Share – Basic (A)/(B)	3.63	(10.27)
6	Adjustment in average number of share for Diluted earnings per share	-	-
7	Diluted Earnings Per Share	3.63	(10.27)

Note : 23 Deferred Tax

Amount in ₹

S.No	Particulars	31-Mar-18	31-Mar-17
1	Depreciation as per Companies Act	38,65,131	47,21,132
2	Depreciation as per Income Tax Act	33,38,386	39,23,076
3	Timing Difference	(5,26,745)	(7,98,056)
4	Current Year Deferred Tax (Asset)/ Liability	(1,36,954)	(2,46,599)
5	Opening Balance	(7,540)	2,39,059
	Closing Balance (Asset)/Liability	(1,44,494)	(7,540)

Note : 24 Payments To Auditors

Amount in ₹

S.No	Particulars	31-Mar-18	31-Mar-17
1	Statutory Audit Fees	30,000	30,000
2	Tax Audit Fees	10,000	10,000
3	GST/Service Tax	7,200	6,000
	Total	47,200	46,000

Note : 25 Related Party Disclosure

As per the Accounting Standard-18 on 'Related party disclosures' as notified by the Companies (accounting Standards) Rules-2006 the related parties of the company are as follows.

List of related parties

1. Key management personnel
 - a) Shashikant Tewary - Managing Director
 - b) DN Rao - Director
2. Group Companies
 - a) Gram Tarang Self Help Co-Operative Ltd.

Transactions with related parties

Amount in ₹

Particulars	Key Management Personnel		Group Companies	
	31-Mar-18	31-Mar-17	31-Mar-18	31-Mar-17
Shashikant Tewary Unsecured Loan	4,58,130	4,58,130	-	-
Unsecured Loan from Gram Tarang SelfHelp Co-Operative society	1,02,54,696	1,02,54,696	1,02,54,696	1,02,54,696

GRAM TARANG FOODS PRIVATE LIMITED

Note: 26 Disclosure required under Section 22 of the Micro, Small and Medium Enterprises Development Act, 2006

S No	Particulars	31-Mar-18	31-Mar-17
1	Principal amount remaining unpaid to any supplier as at the end of the accounting year		
2	Interest due thereon remaining unpaid to any supplier as at the end of the accounting year		
3	The amount of interest paid along with the amounts of the payment made to the supplier beyond the appointed day		
4	The amount of interest due and payable for the year	NIL	NIL
5	The amount of interest accrued and remaining unpaid at the end of the accounting year		
6	The amount of further interest due and payable even in the succeeding year, until such date when the interest dues as above are actually paid		

Note 27:

Previous year's figures have been regrouped / reclassified wherever necessary to correspond with the current year's classification / disclosure.

As per our report of even date attached to the
Balance Sheet and Profit and Loss Account

For SPC & Associates
Chartered Accountants
FRN: 005685S

CA Shrvan Kumar Reddy

Partner
MRN:240014

Hyderabad
Date: 17-08-2018

For GRAM TARANG FOODS PRIVATE LIMITED

Shashikant Tewary

Managing Director
DIN : 6453360



D.N.Rao

Director
DIN: 00939956

**FORM NO. MGT 9
EXTRACT OF ANNUAL RETURN**

As on financial year ended on 31.03.2018

[Pursuant to Section 92 (3) of the Companies Act, 2013 and rule 12(1) of the Company (Management & Administration) Rules, 2014.]

I. REGISTRATION & OTHER DETAILS:

1.	CIN	U15549AP2009PTC064398
2.	Registration Date	16/07/2009
3.	Name of the Company	GRAM TARANG FOODS PRIVATE LIMITED
4.	Category/Sub-category of the Company	A Non-Government Company limited by shares
5.	Address of the Registered office & contact details	B-107, KSR Pleasant Valley, Madhavadhara, Visakhapatnam, Andhra Pradesh-530018.
6.	Whether listed company	No
7.	Name, Address & contact details of the Registrar & Transfer Agent, if any.	ROC-Hyderabad.

II. PRINCIPAL BUSINESS ACTIVITIES OF THE COMPANY (All the business activities contributing 10 % or more of the total turnover of the company shall be stated)

S. No.	Name and Description of main products / services	NIC Code of the Product/service	% to total turnover of the company
1	Food Products	1040	100%

III. PARTICULARS OF HOLDING, SUBSIDIARY AND ASSOCIATE COMPANIES-

Sino	Name and Address of the Company	CIN/GLN	Holding/ Subsidiary/ Associate	% of shares held	Applicable Section
NIL					

B) Shareholding of Promoter-

SN	Shareholder's Name	Shareholding at the beginning of the year			Shareholding at the end of the year			% change in shareholding during the year
		No. of Shares	% of total Shares of the company	% of Shares Pledged / encumbered to total shares	No. of Shares	% of total Shares of the company	% of Shares Pledged / encumbered to total shares	
1	Mukti Kantha Mishra	118334	22.54%	-	118334	22.54%	-	-
2	Shashikanth Tewary	163333	31.11%	-	163333	31.11%	-	-
3	Supriya Patanaik	50000	9.52%	-	50000	9.52%	-	-
4	DN Rao	163333	31.11%	-	168333	31.11%	-	-

C) Change in Promoters' Shareholding (please specify, if there is no change)

SN	Particulars	Shareholding at the beginning of the year		Cumulative Shareholding during the year	
		No. of shares	% of total shares of the company	No. of shares	% of total shares of the company
	At the beginning of the year				
	Date wise Increase / Decrease in Promoters Shareholding during the year specifying the reasons for increase /decrease (e.g. allotment / transfer / bonus/ sweat equity etc.)				
	At the end of the year				

There is no change in shareholding during the year.

D) Shareholding Pattern of top ten Shareholders:

(Other than Directors, Promoters and Holders of GDRs and ADRs):

Sl. No	For Each of the Top 10 Shareholders	Shareholding at the beginning of the year		Cumulative Shareholding during the year	
		No. of shares	% of total shares of the company	No. of shares	% of total shares of the company
	At the beginning of the year	-	-	-	-
	Date wise Increase / Decrease in Shareholding during the year specifying the reasons for increase /decrease (e.g. allotment / transfer / bonus/ sweat equity etc):	-	-	-	-
	At the end of the year	-	-	-	-

E) Shareholding of Directors and Key Managerial Personnel:

Sl. No	Shareholding of each Directors and each Key Managerial Personnel	Shareholding at the beginning of the year		Cumulative Shareholding during the year	
		No. of shares	% of total shares of the company	No. of shares	% of total shares of the company
	At the beginning of the year	3,31,666	63.17%	3,31,666	63.17%
	Date wise Increase / Decrease in Shareholding during the year specifying the reasons for increase /decrease (e.g. allotment / transfer / bonus/ sweat equity etc.)	-	-	-	-
	At the end of the year	3,31,666	63.17%	3,31,666	63.17%

V) INDEBTEDNESS -Indebtedness of the Company including interest outstanding/accrued but not due for payment.

Particulars	Secured Loans excluding deposits	Unsecured Loans	Deposits	Total Indebtedness
Indebtedness at the beginning of the financial year				
i) Principal Amount	86,66,349	1,52,12,826	-	2,38,79,175
ii) Interest due but not paid	-	-	-	-
iii) Interest accrued but not due	-	-	-	-
Total (i+ii+iii)	86,66,349	1,52,12,826	-	2,38,79,175
Change in Indebtedness during the financial year				
* Addition	-	-	-	-
* Reduction	(43,78,925)			(43,78,925)
Net Change	(43,78,925)			(43,78,925)
Indebtedness at the end of the financial year				
i) Principal Amount	42,87,424	1,52,12,826		1,95,00,250
ii) Interest due but not paid	-	-	-	-
iii) Interest accrued but not due	-	-	-	-
Total (i+ii+iii)	42,87,424	1,52,12,826		1,95,00,250

VI. REMUNERATION OF DIRECTORS AND KEY MANAGERIAL PERSONNEL-

A. Remuneration to Managing Director, Whole-time Directors and/or Manager:

SN.	Particulars of Remuneration	Name of MD/WTD/ Manager		Total
1	Gross salary	Not Applicable		
	(a) Salary as per provisions contained in section 17(1) of the Income-tax Act, 1961			
	(b) Value of perquisites u/s 17(2) Income-tax Act, 1961			
	(c) Profits in lieu of salary under section 17(3) Income- tax Act, 1961			
2	Stock Option			
3	Sweat Equity			
4	Commission - as % of profit - others, specify...			
5	Others, please specify(TDS)			
	Total (A)			
	Ceiling as per the Act			

B. Remuneration to other directors

SN.	Particulars of Remuneration	Name of Directors	Total Amount
1	Independent Directors	NIL	
	Fee for attending board committee meetings		
	Commission		
	Others, please specify		
	Total (1)		
2	Other Non-Executive Directors		
	Fee for attending board committee meetings		
	Commission		
	Others, please specify		
	Total (2)		
	Total (B)=(1+2)		
	Total Managerial Remuneration		
	Overall Ceiling as per the Act		

C. REMUNERATION TO KEY MANAGERIAL PERSONNEL OTHER THAN MD/MANAGER/WTD

SN	Particulars of Remuneration	Key Managerial Personnel			
		CEO	CS	CFO	Total
1	Gross salary		NIL		
	(a) Salary as per provisions contained in section 17(1) of the Income-tax Act, 1961				
	(b) Value of perquisites u/s 17(2) Income-tax Act, 1961				
	(c) Profits in lieu of salary under section 17(3) Income-tax Act, 1961				
2	Stock Option				
3	Sweat Equity				
4	Commission				
	- as % of profit				
	Others, specify...				
5	Others, please specify				
	Total				

VII. PENALTIES / PUNISHMENT / COMPOUNDING OF OFFENCES:

Type	Section of the Companies Act	Brief Description	Details of Penalty / Punishment/ Compounding fees imposed	Authority [RD / NCLT/ COURT]	Appeal made, if any (give Details)
A. COMPANY					
Penalty			NIL		
Punishment					
Compounding					
B. DIRECTORS					
Penalty			NIL		
Punishment					
Compounding					
C. OTHER OFFICERS IN DEFAULT					
Penalty			NIL		
Punishment					
Compounding					

IV. SHARE HOLDING PATTERN
(Equity Share Capital Breakup as Percentage of Total Equity)

Category of Shareholders	No. of Shares held at the end of the year [As on 31-March-2016]			No. of Shares held at the end of the year [As on 31-March-2017]			% Change during the year
	Physical	Total	% of Total Shares	Physical	Total	% of Total Shares	
A. Promoters							
(1) Indian							
a) Individual/ HUF	4,50,000	4,50,000	85.71%	4,50,000	4,50,000	85.71%	0%
b) Central Govt							
c) State Govt(s)							
d) Bodies Corp.							
e) Banks / FI							
f) Any other							
Total shareholding of Promoter (A)	4,50,000	4,50,000	85.71%	4,50,000	4,50,000	85.71%	0%
B. Public Shareholding							
1. Institutions							
a) Mutual Funds							
b) Banks / FI							
c) Central Govt							
d) State Govt(s)							
e) Venture Capital Funds							
f) Insurance Companies							
g) FIIs							
h) Foreign Venture Capital Funds							



29th September, 2018

To,

M/s. SPC & Associates,
Chartered Accountants,
Plot No-252A, Lotus pond Road
Road No-12, Banjara Hills
Hyderabad- 500034.

Dear Sir,

Sub.: Appointment as Statutory Auditors for the F.Y. 2018-19– reg.
Ref.: 9th Annual General Meeting of the Company.

This has reference to the above cited subject and 9th Annual General Meeting of the Company was held on Saturday, 29th September 2018.

In this regard, we are pleased to inform you that you firm M/s. SPC & Associates Chartered Accountants be and here by appointed as statutory auditors of the company to hold office from the conclusion of this Meeting until the conclusion of the Annual General Meeting (AGM) of the company to be held in the year 2019 subject to ratification of the appointment at every AGM at a remuneration (including term of payment) to be fixed by the board of Direction of the company, plus Goods and service tax and such other taxes, as may be applicable & reimbursement of all out-of-pocket expenses in connection with the audit of the accounts of the company.

This is for your information and necessary action.

Thanking you

Yours truly,

For GRAM TARANG FOODS PRIVATE LIMITED

Shashikanth Tewary
Director
DIN – (06453360)



Date: 10th July, 2018

To
SPC & Associates,
Chartered Accountants,
Plot No #252A, 2nd Floor, MLA Colony,
Lotus Pond Road, Road #12, Banjara Hills,
Hyderabad.

Dear Sirs,

FINANCIAL STATEMENTS FOR THE PERIOD ENDED 31st MARCH, 2018

This representation letter is provided in connection with your audit of the financial statements of **Gram Tarang Foods Private Limited** for the year ended **31st March, 2018**, for the purpose of expressing an opinion as to whether the financial statements give a true and fair view of the financial position of **Gram Tarang Foods Private Limited** as of **31st March, 2018**, and of the results of its operations for the year then ended in accordance with the Companies Act, 2013 and Generally Accepted Accounting Practices in India.

We acknowledge our responsibility for the fair presentation of the financial statements in accordance with the Companies Act, 2013 and Generally Accepted Accounting Practices in India.

We confirm to the best of our knowledge and belief, the following representations:

- We acknowledge our responsibilities for the design, implementation, and operation of accounting and internal control systems that are designed to prevent and detect fraud and error.
- Following our assessment of the risk that the financial statements may be materially misstated as a result of fraud, we are not aware of any significant facts relating to any frauds or suspected frauds or irregularities known that have involved (i) Management; (ii) Employees who have significant roles in internal control; or (iii) Others where the fraud could have a material effect on the financial statements; and, of any allegations of fraud, or suspected fraud, affecting the financial statements that have been communicated to us by employees, former employees, analysts, regulators and others.
- We have made available to you all books of account and supporting documentation and all minutes of meetings of shareholders and the board of directors.
- We confirm the completeness of the information provided regarding the identification of related parties. Related party transactions are conducted on terms substantially equivalent to those that prevail in an arm's length transaction except for the loans taken.
- The related party loans have been taken for aiding the business activities and hence they were granted without any interest.
- We are aware of the observations you made, qualifications reported and notes attached to the accounts. We assure you that all necessary steps will be taken by the management to follow the best practices, implement the suggestions made and comply with those rules and regulations which could not be done during the year.



- We accept that the Company has delayed in filing forms with the Registrar of Companies regarding the shares allotted to the new investors. We are also aware of the fact that the Company's borrowings are more than the net worth of the Company.
- The Company is not covered under any of the labour laws as of now but it shall be responsible to deposit the statutory contributions once it is covered under the Acts.
- We are also aware of the fact that the Company shall be responsible to revise the VAT (statutory) returns.
- The Company has complied with all aspects of contractual agreements that could have a material effect on the financial statements in the event of non-compliance. There has been no non-compliance with requirements of regulatory authorities that could have a material effect on the financial statements in the event of non-compliance.
- The following have been properly recorded and when appropriate, adequately disclosed in the financial statements:
 - (a) The identity of, and balances and transactions with, related parties.
 - (b) All litigation, claims or possible claims and estimates thereof.
- We have no plans to abandon lines of product or other plans or intentions that will result in any excess or obsolete inventory, and no inventory is stated at an amount in excess of net realisable value.
- The Company has satisfactory title to all assets and there are no liens or encumbrances on the Company's assets.
- We have recorded or disclosed, as appropriate, all liabilities both actual and contingent, and have disclosed in the notes to the financial statements all guarantees that we have given to third parties, if any.
- Events subsequent to period end which require adjustment of or disclosure in the financial statements or notes thereto are as disclosed in the financial statements.
- We have assessed future action relating to continuing operations and confirm that there are no events or conditions that have been identified, indicating that the Company will not be a going concern.
- The management hereby confirms that none of the directors is disqualified as on March 31, 2018, from being appointed as a director in terms of sub-section (2) of Section 164 of the Companies Act, 2013.

Yours faithfully

Gram Tarang Foods Private Limited

Shashikant Tewary

Director

DIN : 6453360

Independent Auditor's Report

To the Members of
GRAM TARANG FOODS PRIVATE LIMITED

Report on the Financial Statements

We have audited the accompanying financial statements of **GRAM TARANG FOODS PRIVATE LIMITED** ("the Company"), which comprise the Balance Sheet as at 31st March, 2018, the Statement of Profit and Loss and the statement of cash flows for the year ended and a summary of significant accounting policies and other explanatory information.

Management's Responsibility for the Financial Statements

The Company's Board of Directors is responsible for the matters stated in Section 134(5) of the Companies Act, 2013 ("the Act") with respect to the preparation and presentation of these financial statements that give a true and fair view of the financial position, financial performance and of the Company in accordance with the accounting principles generally accepted in India, including the Accounting Standards specified under Section 133 of the Act, read with Rule 7 of the Companies (Accounts) Rules, 2014.

This responsibility also includes maintenance of adequate accounting records in accordance with the provisions of the Act for safeguarding the assets of the Company and for preventing and detecting frauds and other irregularities; selection and application of appropriate accounting policies; making judgments and estimates that are reasonable and prudent; and design, implementation and maintenance of adequate internal financial controls, that were operating effectively for ensuring the accuracy and completeness of the accounting records, relevant to the preparation and presentation of the financial statements that give a true and fair view and are free from material misstatement, whether due to fraud or error.

Auditor's Responsibility for the Financial Statements

Our responsibility is to express an opinion on these financial statements based on our audit. We have taken into account the provisions of the Act, the accounting and auditing standards and matters which are required to be included in the audit report under the provisions of the Act and the Rules made there under.



We conducted our audit in accordance with the Standards on Auditing specified under Section 143(10) of the Act. Those Standards require that we comply with ethical requirements and plan and perform the audit to obtain reasonable assurance about whether the financial statements are free from material misstatement.

An audit involves performing procedures to obtain audit evidence about the amounts and the disclosures in the financial statements. The procedures selected depend on the auditor's judgment, including the assessment of the risks of material misstatement of the financial statements, whether due to fraud or error. In making those risk assessments, the auditor considers internal financial controls relevant to the Company's preparation of the financial statements that give a true and fair view in order to design audit procedures that are appropriate in the circumstances.

An audit also includes evaluating the appropriateness of the accounting policies used and the reasonableness of the accounting estimates made by the Company's Directors, as well as evaluating the overall presentation of the financial statements.

We believe that the audit evidence we have obtained is sufficient and appropriate to provide a basis for our audit opinion on the financial statements

Opinion

In our opinion and to the best of our information and according to the explanations given to us, the financial statements give the information required by the Act in the manner so required and give a true and fair view in conformity with the accounting principles generally accepted in India:

- a) In the case of the Balance Sheet, of the state of affairs of the Company as at March 31, 2018;
- b) In the case of the Statement of Profit and Loss, of the profit for the year ended on that date.
- c) In the case of the statement of cash flows, the cash flows for the year ended on that date

Report on Other Legal and Regulatory Requirements

1. As required by the Companies (Auditor's Report) Order, 2016 ("the Order") issued by the Central Government of India in terms of sub-section (11) of section 143 of the Act, 2013 is not applicable
2. As required by Section 143(3) of the Act, we report that:
 - a) We have obtained all the information and explanations which to the best of our knowledge and belief were necessary for the purpose of our audit;





SPC&ASSOCIATES

Chartered Accountants

- b) In our opinion proper books of account as required by law have been kept by the Company so far as appears from our examination of those books
- c) The Balance Sheet and the Statement of Profit and Loss, dealt with by this Report are in agreement with the books of accounts and returns.
- d) In our opinion, the Balance Sheet, Statement of Profit and Loss, comply with the Accounting Standards referred to in of Section 133 of the Companies Act, 2013, read with Rule 7 of the Company (Accounts) Rules 2014.
- e) On the basis of written representations received from the directors as on March 31, 2018, and taken on record by the Board of Directors, none of the directors is disqualified as on March 31, 2018, from being appointed as a director in terms of sub-section (2) of Section 164 of the Companies Act, 2013.
- f) With respect to the other matters included in the Auditor's Report and to our best of our information and according to the explanations given to us:
 - i) The Company does not have any pending litigations which would impact its financial position.
 - ii) The Company has not entered into any long-term contracts including derivatives contracts requiring provision under applicable laws or accounting standards, for material foreseeable losses and
 - iii) No amount is required to be transferred to investor education and protection fund in accordance with the relevant provisions of the Companies Act, 2013. Hence delay in depositing the amounts to the said fund is not applicable.

For SPC&Associates
Chartered Accountants
FRN: 005685S

CA Shrvan Kumar Reddy
Partner
MRN: 240014

Place: Vishakhapatnam
Date: 17th August, 2018

Principal Place of Business/Bill To						Supply To					
RSB Transmissions (I) Ltd. (Forging Plant) Plot no. 1007, 1011 P.O. Uchapada Tel : 91674-2550590 Fax : 91674-2550590 Email : ranjan.jena@rsbglobal.com Website : www.rsbglobal.com GSTIN : 21AABCR3925R1Z5 PAN : AABCR3925R State Code & State : 21 ODISHA CIN : U34102PN1989PLC014807						RSB TRANSMISSIONS (I) LTD. (Cuttack) CUTTACK UNIT -1, NH-5,PLOT NO.1011,1007 MANIA,KOTSAHI,TANGI.CHOUDWAR 754022 Tel : 91674-2550590 Fax : 91674-2550590 Email : ranjan.jena@rsbglobal.com Website : www.rsbglobal.com GSTIN : 21AABCR3925R1Z5 PAN : AABCR3925R State Code & State : 21 ODISHA CIN : U34102PN1989PLC014807					
Supplier Details						PO Details					
Supplier Code : 40536453 Name : GramTarang Employability Trng Serv P Ltd Address : HIG5,BDA Duplex phase-I Pokhariput GTET,At.JITM,PO.R.Sitapur,Via.Uppalada , Paralakhemundi Tel : Email : sidharth.dash@gramtarang.org.in GSTIN : 21AABCC9406C1ZB PAN : AABCC9406C State Code & State : 21 ODISHA						Order Type/Order No : OH / 18000408 Order Date : 09/18/18 Revision No/ Date : 0 / 09/22/18 Quotation No/ Date : Our Reference No. : Original Order No. : Validity Date : 03/31/19					
No.	Item Code	Drawing No.	HSN	Quantity	Rate	GST Amount/Percentage			Request Date	Amount (Qty x Rate)	
	Description	Mod No:	SAC	UOM	Currency	IGST	CGST	SGST			
1	M06050020 SHEARING BLADE 65X65 WITH MATERIAL		84559000	20.000 EA	7420.00 INR		13356.00 @ 9.0 %	13356.00 @ 9.0 %	09/18/18	148400.00	
2	M06050021 SHEARING BLADE 75X75 WITH MATERIAL		84559000	10.000 EA	7420.00 INR		6678.00 @ 9.0 %	6678.00 @ 9.0 %	09/18/18	74200.00	
									Total :	222600.00	
									CGST Input@9%	20034.00	
									SGST Input@9%	20034.00	
									Other		
									Suspense Account		
									Suspense Setoff Account		
									Grand Total :	262668.00	
Grand Total (In Words) : Rupees Two Lakh Sixty Two Thousand Six Hundred Sixty Eight Only. Delivery Terms : AS PER LAST SUPPLY. Remarks : Payment Terms : 30 Days From Acceptance											

Checked By

Authorized By

Principal Place of Business/Bill To					Supply To					
RSB Transmissions (I) Ltd. (Forging Plant) Plot no. 1007, 1011 P.O. Uchapada Tel : 91674-2550590 Fax : 91674-2550590 Email : ranjan.jena@rsbglobal.com Website : www.rsbglobal.com GSTIN : 21AABCR3925R1Z5 PAN : AABCR3925R State Code & State : 21 ODISHA CIN : U34102PN1989PLC014807					RSB TRANSMISSIONS (I) LTD.(Cuttack) CUTTACK UNIT -1, NH-5,PLOT NO.1011,1007 MANIA,KOTSAHI,TANGI.CHOUDWAR 754022 Tel : 91674-2550590 Fax : 91674-2550590 Email : ranjan.jena@rsbglobal.com Website : www.rsbglobal.com GSTIN : 21AABCR3925R1Z5 PAN : AABCR3925R State Code & State : 21 ODISHA CIN : U34102PN1989PLC014807					
Supplier Details					PO Details					
Supplier Code : 40536453 Name : GramTarang Employability Trng Serv P Ltd Address : HIG5,BDA Duplex phase-I Pokhariput GTET,At.JITM,PO.R.Sitapur,Via.Uppalada , Paralakhemundi Tel : Email : sidharth.dash@gramtarang.org.in GSTIN : 21AABCC9406C1ZB PAN : AABCC9406C State Code & State : 21 ODISHA					Order Type/Order No : OH / 17000471 Order Date : 12/11/17 Revision No/ Date : 0 / 12/12/17 Quotation No/ Date : Our Reference No. : mail dt.20.11.2017 Original Order No. : Validity Date : 03/30/18					
No.	Item Code	Drawing No.	HSN	Quantity	Rate	GST Amount/Percentage			Request Date	Amount
	Description	Mod No:	SAC	UOM	Currency	IGST	CGST	SGST		(Qty x Rate)
1	M06050020 SHEARING BLADE 65X65		84559000	3.000 EA	7420.00 INR		2003.40 @ 9.0 %	2003.40 @ 9.0 %	12/11/17	22260.00
2	M06050021 SHEARING BLADE 75X75		84559000	3.000 EA	7420.00 INR		2003.40 @ 9.0 %	2003.40 @ 9.0 %	12/11/17	22260.00
									Total :	44520.00
									CGST Input@9%	4006.80
									SGST Input@9%	4006.80
									Grand Total :	52533.60
Grand Total (In Words) : Rupees Fifty Two Thousand Five Hundred Thirty Three and paise Sixty Only. Delivery Terms : EX-WORKS. Remarks : Payment Terms : 30 Days From Acceptance										

Checked By

Authorized By

For all queries related to this order contact
 www.rsbglobal.com
 CORPORATE OFFICE: Ubale Nagar, Nagar Road, Wagoli, Pune, 412207, Tel : 91 20 30642100 Fax : 91 20 30642101

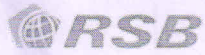

PURCHASE ORDER

RSB TRANSMISSIONS (I) LTD - Cuttack

Cuttack Unit -1, Nh-5,Plot No.1011,1007
 Mania,Kotsahi,Tangi,Choudwar 754022 (Odisha)
 Tel : 91674- 2550590
 Fax : 91674- 2550590
 Email : dilip.kayastha@rsbglobal.com
 Website : www.rsbglobal.com

VAT No. / TIN : 21821119946 w.e.f : Dec 3, 2009
 CST No. / TIN : 21821119946-C w.e.f : Dec 3, 2009
 ECC No. : AABCR3925RXM007
 RANGE : II, Kapaleswar, Choudwar, Cuttack-754025
 DIVISION : Sector-6,Abhinay Bidanas, C.D.A, Cuttack
 COMMISSIONERATE : BBSR-1, Central Revenu Bldg,RajaswaVihar
 PAN : AABCR3925R

SUPPLIER DETAILS
40536453 Gramtarang Employability Trng Serv P Ltd Hig5,Bda Duplex Phase-I Pokhariput Gtet,At.Jitm,Po.R.Sitapur,Via.Uppalada Paralakhemundi sidharth.dash@gramtarang.org.in PAN # AABCC9406C

PO DETAILS
Order Type/ Number : OH / 16000139 Order Date : May 10, 2016 Revision No/ Date : 0 / May 10, 2016 Quotation No/ Date : Our Reference Number : Validity Date : Jul 29, 2016

No.	Item Code Description	Drawing No: Mod No:	Quantity UOM	Rate (Currency)	Requested Date	Amount
1	M06050021 SHEARING BLADE 75X75	Mod # : " "	2.00 EA	7420.00 INR	May 10, 2016	14840.00
2	M06050020 SHEARING BLADE 65X65	Mod # : " "	2.00 EA	7420.00 INR	May 10, 2016	14840.00

Total: 29680.00

VAT@5%
Freight 1484.00

Grand Total: 31164.00

Grand Total (in Words) : Rupees Thirty One Thousand One Hundred Sixty Four And Paise Zero Only
 Delivery Terms : Ex-Works
 Remarks :
 Payment Terms : 30 Days From Acceptance

Checked By:

For all queries related to this order contact : ranjan.jana@rsbglobal.com
 CORPORATE OFFICE : Ubale Nagar, Nagar Road, Wagholi, Pune : 412207, Tel : 91 20 30642100 Fax : 91 20 30642100

Authorized By:



PURCHASE ORDER

Principal Place of Business/Bill To					Supply To						
RSB Transmissions (I) Ltd. (Forging Plant) Plot no. 1007, 1011 P.O. Uchapada Tel : 91674-2550590 Fax : 91674-2550590 Email : ranjan.jena@rsbglobal.com Website : www.rsbglobal.com GSTIN : 21AABCR3925R1Z5 PAN : AABCR3925R State Code & State : 21 ODISHA CIN : U34102PN1989PLC014807					RSB TRANSMISSIONS (I) LTD.(Cuttack) CUTTACK UNIT -1, NH-5,PLOT NO.1011,1007 MANIA,KOTSAHI,TANGI,CHOUDWAR 754022 Tel : 91674-2550590 Fax : 91674-2550590 Email : ranjan.jena@rsbglobal.com Website : www.rsbglobal.com GSTIN : 21AABCR3925R1Z5 PAN : AABCR3925R State Code & State : 21 ODISHA CIN : U34102PN1989PLC014807						
Supplier Details					PO Details						
Supplier Code : 40007025 Name : GRAMTARANG EMPLOYABILITY TRNG SERV P LTD Address : C/O ? CENTURION UNIVERSITY GRAM TARANG EMPLOYABILITY TRAINING SERVICES, AT- RAMACHANDRAPUR,JATANI , BHUBANESWAR Tel : Email : subratkumar.swain@gramtarang.org.in GSTIN : 21AABCC9406C1ZB PAN : AABCC9406C State Code & State : 21 ODISHA					Order Type/Order No : O2 / 18000210 Order Date : 09/14/18 Revision No/ Date : 0 / 09/14/18 Quotation No/ Date : Our Reference No. : Original Order No. : Validity Date : 12/14/18						
No.	Item Code	Drawing No.	HSN	Quantity	Rate	GST Amount/Percentage			Request Date	Amount (Qty x Rate)	
	Description	Mod No:	SAC	UOM	Currency	IGST	CGST	SGST			
1	ZMRS0069 FINISHER TOP D1203L WELDING DIE REPAIR		998331	2.000 EA	6202.80 INR		1116.50 @ 9.0 %	1116.50 @ 9.0 %	09/14/18	12405.60	
2	ZMRS0069 BLOCKER TOP D1203L WELDING DIE REPAIR		998331	1.000 EA	4032.00 INR		362.88 @ 9.0 %	362.88 @ 9.0 %	09/14/18	4032.00	
3	ZMRS0069 FINISHER BOTTOM D1203L WELDING DIE REPAIR		998331	1.000 EA	4320.00 INR		388.80 @ 9.0 %	388.80 @ 9.0 %	09/14/18	4320.00	
									Total :	20757.60	
									CGST Input@9%	1868.18	
									SGST Input@9%	1868.18	
									Other		
									Suspense Account		
									Suspense Setoff Account		
									Grand Total :	24493.97	
Grand Total (In Words) : Rupees Twenty Four Thousand Four Hundred Ninety Three and paise Ninety Seven Only. Delivery Terms : Remarks : Payment Terms : 30 Days From Acceptance											

Checked By

Authorized By

For all queries related to this order contact
www.rsbglobal.com

CORPORATE OFFICE: Ubale Nagar, Nagar Road, Wagoli, Pune, 412207, Tel : 91 20 30642100 Fax : 91 20 30642101

TERMS & CONDITIONS**GENERAL**

1. Written acceptance of this PO or Commencement of supply/service against this PO shall constitute acceptance of this Purchase Order.
2. Delivery Challan/Invoice in duplicate should accompany all supplies made mentioning in there clearly supplier code, drawing no., part no., description of material PO no. specified in Purchase/subcontract & quantity supplied.
3. In the case of excisable goods transporter's copy should be send along with material otherwise bill/invoice will be held up. Failure to comply with this & consequent loss of mod vat credit on account of excise duty will be debited to your account where document are routed through bank send the transporter copy along with consent & enclose copy of invoice with document routed through bank. Attested/certified/Photostat copies of transporter's copy of invoice are not acceptable at all.
4. In case of subcontract item with our material failure to supply or return the material within 90 days under rule 4(5)(a) of central excise the excise duty payable in then will be debited to your account.
5. All drawings samples or technical data supplied to you by us shall be kept as secret & shall not be sold or disclosed & these shall be returned to as & when demanded. Failure to comply with this shall make you liable for breach of trust & other actions as may be deemed fit by us.
6. The items manufactured by you from the date furnished by us must not be sold or divulged by you to any other party than ourselves. If you manufacture excess quantity than our order you shall preserve the same for ultimate sale to us on our demand. Alternatively you destroy the goods so manufactured by you. By no account you will sell goods to any other party except with our written consent. The same condition applies to supplies rejected by us parts similar to parts manufactured for us; should not be manufactured by you.
7. No upward revision of price will be permitted during the period of contract unless agreed by us.
8. Terms & condition stated in our purchase/subcontract will be final until the supplier has our written consent to his terms & conditions if any stated in his order acceptance letter.
9. Any letter sent by prepaid registered post to the address given in this order shall be deemed to have been received by party within 3 days of dispatch thereof; irrespective of fact whether the said letter is or is not in fact received by party so addressed.
10. The company reserves the right to cancel & terminate the contract. If prevented by any intervention or control by government authorities or any other cause beyond the control of the company where by company is unable to make use the materials ordered by stoppage suspension of production or otherwise.
11. Local civil court shall have the jurisdiction to try any dispute concerning all our purchase/subcontract.
12. The material should be properly packed to avoid any kind of damage or formation of rust during transportation or storage.
13. Strict adherence to terms of delivery is absolutely essential. The company reserves the right to treat the order as cancelled in the event of your non-compliance of delivery schedule agreed & material will be brought from open market at your risk & cost. Time of delivery shall be essence of contract.
14. Demurrage, penalties etc. shall be levied on account of delay in delivery, dispatch or railway/lorry receipts, advance of invoice & challans or any other shipping documents or for any other reason for which the company is not responsible will be to the supplier's account & recoverable from him.
15. The material must be dispatched by the mode or transport & to the destination mentioned in this order. In case partial suppliers our prior approval must be obtained.
16. If transport arrangement is made by RSB for collection & dispatch of components it will be totally the supplier's risk RSB is not responsible for any shortages damages in such Arrangement supplier should send their representative with each consignment for collection & delivery to ensure safe transit of material.
17. Supplier shall give advance information to buyer in writing for all specification change design changes as well as major changes in processing location of manufacturing applying to goods covered by this Purchase order.
18. All vehicles used for transportation of material should comply to the central motor & vehicle rules act as applicable from time to time. The transporter is required to carry PUC vehicle fitness certificate of transportation vehicle during delivery.
19. Supplier should inform dispatch details immediately after dispatch.
20. Material supplied by seller shall satisfy current Govt. & environmental (ISO 14001-2004) & safety (OHSAS-18001-2007) constraints on restricted toxic & hazardous materials.
21. Supplier shall ensure coverage of transit insurance for material.
22. Supplier shall protect the third party trade secret or proprietary information for material or copy rights supplied by RSB. Failure to do so will result in PO being cancelled with immediate effect.

PAYMENT

1. Payment will be made as stipulated in this order, if the payment is agreed to be made against document through Bank. All bank charges involved shall be borne by the Supplier. Failure by the Supplier to advice his banker to recover all bank charges from supplier. Will result is non-retirement of documents at his own risk and cost.
2. All payments will be done as per applicable RSB policies.
3. No charges for cartage, packing etc., will admissible unless the same is specifically included in our Purchase/ Sub Contract.

SUPPLIER'S QUALITY ASSURANCE

1. All the materials, Component supplied must critically meet RSB Quality standards required as per samples, drawings, specifications or any other related instructions. The supplier shall allow, RSB's employee and authorized representatives for the purpose of inspecting manufacturing and inspection facilities, inspection of raw materials, WIP, FG, machines tools, fixtures jigs or any other items in connection with the manufacture of components for the company.

SAMPLE APPROVAL

1. No supplies should be made prior to the approval of sample unless specifically asked by us. It shall be the responsibility of the Supplier to submit samples well in time to be able to adhere strictly to the delivery schedule.

REJECTIONS

1. The decisions of the company on rejection shall be final and binding on the Supplier and this time clause shall be deemed to constitute an agreement to the contrary under the Sale of Goods Act. The company shall be entitled to reject the materials at any stage, cancel the contract and buy its requirements in the open market against the supplies. There is no rejection allowed unless specifically mentioned in the P.O. clearly.
2. It will be the liability of the Supplier to remove the rejected material within 15 days from our premises at his cost. In case rejection is not taken back within 15 days RSB is not liable to return back the rejection & no compensation will be given. In case of any rework done the components supplied by the suppliers, rework charges, handling charges, disposal charges & any other related charges as applicable will be recovered from Supplier's bill.
3. Rejection must be replaced within the delivery schedule and will be invoiced separately and not as replacement. All charges inclusive of freight and handling on replacements shall be borne by the Supplier.

WARRANTY

1. All the material supplied, should be free from any manufacturing, process defects & should be as per the drawings, Specifications. Any failure at RSB's customer end due to any deviation on quality, supplier shall be responsible for all damages, claims, recovery directly or indirectly claimed to RSB by any agency. Supplier shall reimburse all such expenses to RSB immediately without any delay on any ground. It will be the responsibility of the supplier to provide free replacement of component & assemblies which fail in the field because of material or manufacturing defects during the Warranty period or during the product life cycle, any offered by the company to its customers.

IN THE CASE OF SUB CONTRACT

1. Material Account to be submitted every month with regards to the Receipts & Supply in the prescribed format.
2. The supplier is responsible for safe custody of Company's material including the RAW Material/ Semi Finished/Finished/Tooling.
3. Periodic Physical Verification will be carried out by company's representative. During which supplier should assist in such verification.
4. The supplier has to obtain in writing the quantum to be consumed for each item supplied to him.
5. Supplier is fully responsible for quantity lifted by him till the entire quantity is supplied by him as per specification.
6. The supplier should also return the resultant scrap generated during machining. The remaining material/semi finished/finished held by supplier shall be property of company & company reserves the right to seek for return of raw material in which event the supplier shall return the same forth with.
7. No process rejection is allowed unless specified in PO specifically. In case process rejection, rejected component should be returned back to RSB on a separate delivery challan. All such components should be marked with red paint & to be supplied in a separate batch to avoid mix up. Process rejection exceeding allowed rejection % full cost of raw material shall be recovered. Line rejection at RSB is not considered in the allowed process rejection (if any). Line rejection will be recovered at full cost & rejected components will not be returned back or no scrap benefit will be passed on to supplier.
8. Supplier should ensure coverage of insurance of RSB property on their premises at their own cost.

Checked By

Authorized By

For all queries related to this order contact
www.rsbglobal.com

CORPORATE OFFICE: Ubale Nagar, Nagar Road, Wagoli, Pune, 412207, Tel : 91 20 30642100 Fax : 91 20 30642101



PURCHASE ORDER

Principal Place of Business/Bill To					Supply To						
RSB Transmissions (I) Ltd. (Forging Plant) Plot no. 1007, 1011 P.O. Uchapada Tel : 91674-2550590 Fax : 91674-2550590 Email : ranjan.jena@rsbglobal.com Website : www.rsbglobal.com GSTIN : 21AABCR3925R1Z5 PAN : AABCR3925R State Code & State : 21 ODISHA CIN : U34102PN1989PLC014807					RSB TRANSMISSIONS (I) LTD.(Cuttack) CUTTACK UNIT -1, NH-5,PLOT NO.1011,1007 MANIA,KOTSAHI,TANGI,CHOUDWAR 754022 Tel : 91674-2550590 Fax : 91674-2550590 Email : ranjan.jena@rsbglobal.com Website : www.rsbglobal.com GSTIN : 21AABCR3925R1Z5 PAN : AABCR3925R State Code & State : 21 ODISHA CIN : U34102PN1989PLC014807						
Supplier Details					PO Details						
Supplier Code : 40007025 Name : GRAMTARANG EMPLOYABILITY TRNG SERV P LTD Address : C/O ? CENTURION UNIVERSITY GRAM TARANG EMPLOYABILITY TRAINING SERVICES, AT- RAMACHANDRAPUR,JATANI , BHUBANESWAR Tel : Email : subratkumar.swain@gramtarang.org.in GSTIN : 21AABCC9406C1ZB PAN : AABCC9406C State Code & State : 21 ODISHA					Order Type/Order No : O2 / 18000292 Order Date : 11/27/18 Revision No/ Date : 0 / 11/27/18 Quotation No/ Date : Our Reference No. : Original Order No. : Validity Date : 01/27/19						
No.	Item Code	Drawing No.	HSN	Quantity	Rate	GST Amount/Percentage			Request Date	Amount (Qty x Rate)	
	Description	Mod No:	SAC	UOM	Currency	IGST	CGST	SGST			
1	ZMRS0069 MACHINING CHARGES OF WELDED DIE 1123L FINISHER BOTTOM		998331	1.000 EA	4644.00 INR		417.96 @ 9.0 %	417.96 @ 9.0 %	11/27/18	4644.00	
2	ZMRS0069 MACHINING CHARGES OF WELDED DIE 1123L FINISHER TOP		998331	1.000 EA	4644.00 INR		417.96 @ 9.0 %	417.96 @ 9.0 %	11/27/18	4644.00	
3	ZMRS0069 MACHINING CHARGES OF WELDED DIE 1123L BLOCKER TOP		998331	1.000 EA	4572.00 INR		411.48 @ 9.0 %	411.48 @ 9.0 %	11/27/18	4572.00	
4	ZMRS0069 MACHINING CHARGES OF WELDED DIE 1123L BLOCKER BOTTOM		998331	1.000 EA	4572.00 INR		411.48 @ 9.0 %	411.48 @ 9.0 %	11/27/18	4572.00	
									Total :	18432.00	
									Packing & Forwarding Charges		
									CGST Input@9%	1658.88	
									SGST Input@9%	1658.88	
									Suspense Account		
									Suspense Setoff Account		
									Grand Total :	21749.76	
Grand Total (In Words) : Rupees Twenty One Thousand Seven Hundred Fourty Nine and paise Seventy Six Only. Delivery Terms : EX-WORKS.. Remarks : Payment Terms : 30 Days From Acceptance											

Checked By

Authorized By

For all queries related to this order contact
www.rsbglobal.com

CORPORATE OFFICE: Ubale Nagar, Nagar Road, Wagoli, Pune, 412207, Tel : 91 20 30642100 Fax : 91 20 30642101

TERMS & CONDITIONS**GENERAL**

1. Written acceptance of this PO or Commencement of supply/service against this PO shall constitute acceptance of this Purchase Order.
2. Delivery Challan/Invoice in duplicate should accompany all supplies made mentioning in there clearly supplier code, drawing no., part no., description of material PO no. specified in Purchase/subcontract & quantity supplied.
3. In the case of excisable goods transporter's copy should be send along with material otherwise bill/invoice will be held up. Failure to comply with this & consequent loss of mod vat credit on account of excise duty will be debited to your account where document are routed through bank send the transporter copy along with consent & enclose copy of invoice with document routed through bank. Attested/certified/Photostat copies of transporter's copy of invoice are not acceptable at all.
4. In case of subcontract item with our material failure to supply or return the material within 90 days under rule 4(5)(a) of central excise the excise duty payable in then will be debited to your account.
5. All drawings samples or technical data supplied to you by us shall be kept as secret & shall not be sold or disclosed & these shall be returned to as & when demanded. Failure to comply with this shall make you liable for breach of trust & other actions as may be deemed fit by us.
6. The items manufactured by you from the date furnished by us must not be sold or divulged by you to any other party than ourselves. If you manufacture excess quantity than our order you shall preserve the same for ultimate sale to us on our demand. Alternatively you destroy the goods so manufactured by you. By no account you will sell goods to any other party except with our written consent. The same condition applies to supplies rejected by us parts similar to parts manufactured for us; should not be manufactured by you.
7. No upward revision of price will be permitted during the period of contract unless agreed by us.
8. Terms & condition stated in our purchase/subcontract will be final until the supplier has our written consent to his terms & conditions if any stated in his order acceptance letter.
9. Any letter sent by prepaid registered post to the address given in this order shall be deemed to have been received by party within 3 days of dispatch thereof; irrespective of fact whether the said letter is or is not in fact received by party so addressed.
10. The company reserves the right to cancel & terminate the contract. If prevented by any intervention or control by government authorities or any other cause beyond the control of the company where by company is unable to make use the materials ordered by stoppage suspension of production or otherwise.
11. Local civil court shall have the jurisdiction to try any dispute concerning all our purchase/subcontract.
12. The material should be properly packed to avoid any kind of damage or formation of rust during transportation or storage.
13. Strict adherence to terms of delivery is absolutely essential. The company reserves the right to treat the order as cancelled in the event of your non-compliance of delivery schedule agreed & material will be brought from open market at your risk & cost. Time of delivery shall be essence of contract.
14. Demurrage, penalties etc. shall be levied on account of delay in delivery, dispatch or railway/lorry receipts, advance of invoice & challans or any other shipping documents or for any other reason for which the company is not responsible will be to the supplier's account & recoverable from him.
15. The material must be dispatched by the mode or transport & to the destination mentioned in this order. In case partial suppliers our prior approval must be obtained.
16. If transport arrangement is made by RSB for collection & dispatch of components it will be totally the supplier's risk RSB is not responsible for any shortages damages in such Arrangement supplier should send their representative with each consignment for collection & delivery to ensure safe transit of material.
17. Supplier shall give advance information to buyer in writing for all specification change design changes as well as major changes in processing location of manufacturing applying to goods covered by this Purchase order.
18. All vehicles used for transportation of material should comply to the central motor & vehicle rules act as applicable from time to time. The transporter is required to carry PUC vehicle fitness certificate of transportation vehicle during delivery.
19. Supplier should inform dispatch details immediately after dispatch.
20. Material supplied by seller shall satisfy current Govt. & environmental (ISO 14001-2004) & safety (OHSAS-18001-2007) constraints on restricted toxic & hazardous materials.
21. Supplier shall ensure coverage of transit insurance for material.
22. Supplier shall protect the third party trade secret or proprietary information for material or copy rights supplied by RSB. Failure to do so will result in PO being cancelled with immediate effect.

PAYMENT

1. Payment will be made as stipulated in this order, if the payment is agreed to be made against document through Bank. All bank charges involved shall be borne by the Supplier. Failure by the Supplier to advice his banker to recover all bank charges from supplier. Will result is non-retirement of documents at his own risk and cost.
2. All payments will be done as per applicable RSB policies.
3. No charges for cartage, packing etc., will admissible unless the same is specifically included in our Purchase/ Sub Contract.

SUPPLIER'S QUALITY ASSURANCE

1. All the materials, Component supplied must critically meet RSB Quality standards required as per samples, drawings, specifications or any other related instructions. The supplier shall allow, RSB's employee and authorized representatives for the purpose of inspecting manufacturing and inspection facilities, inspection of raw materials, WIP, FG, machines tools, fixtures jigs or any other items in connection with the manufacture of components for the company.

SAMPLE APPROVAL

1. No supplies should be made prior to the approval of sample unless specifically asked by us. It shall be the responsibility of the Supplier to submit samples well in time to be able to adhere strictly to the delivery schedule.

REJECTIONS

1. The decisions of the company on rejection shall be final and binding on the Supplier and this time clause shall be deemed to constitute an agreement to the contrary under the Sale of Goods Act. The company shall be entitled to reject the materials at any stage, cancel the contract and buy its requirements in the open market against the supplies. There is no rejection allowed unless specifically mentioned in the P.O. clearly.
2. It will be the liability of the Supplier to remove the rejected material within 15 days from our premises at his cost. In case rejection is not taken back within 15 days RSB is not liable to return back the rejection & no compensation will be given. In case of any rework done the components supplied by the suppliers, rework charges, handling charges, disposal charges & any other related charges as applicable will be recovered from Supplier's bill.
3. Rejection must be replaced within the delivery schedule and will be invoiced separately and not as replacement. All charges inclusive of freight and handling on replacements shall be borne by the Supplier.

WARRANTY

1. All the material supplied, should be free from any manufacturing, process defects & should be as per the drawings, Specifications. Any failure at RSB's customer end due to any deviation on quality, supplier shall be responsible for all damages, claims, recovery directly or indirectly claimed to RSB by any agency. Supplier shall reimburse all such expenses to RSB immediately without any delay on any ground. It will be the responsibility of the supplier to provide free replacement of component & assemblies which fail in the field because of material or manufacturing defects during the Warranty period or during the product life cycle, any offered by the company to its customers.

IN THE CASE OF SUB CONTRACT

1. Material Account to be submitted every month with regards to the Receipts & Supply in the prescribed format.
2. The supplier is responsible for safe custody of Company's material including the RAW Material/ Semi Finished/Finished/Tooling.
3. Periodic Physical Verification will be carried out by company's representative. During which supplier should assist in such verification.
4. The supplier has to obtain in writing the quantum to be consumed for each item supplied to him.
5. Supplier is fully responsible for quantity lifted by him till the entire quantity is supplied by him as per specification.
6. The supplier should also return the resultant scrap generated during machining. The remaining material/semi finished/finished held by supplier shall be property of company & company reserves the right to seek for return of raw material in which event the supplier shall return the same forth with.
7. No process rejection is allowed unless specified in PO specifically. In case process rejection, rejected component should be returned back to RSB on a separate delivery challan. All such components should be marked with red paint & to be supplied in a separate batch to avoid mix up. Process rejection exceeding allowed rejection % full cost of raw material shall be recovered. Line rejection at RSB is not considered in the allowed process rejection (if any). Line rejection will be recovered at full cost & rejected components will not be returned back or no scrap benefit will be passed on to supplier.
8. Supplier should ensure coverage of insurance of RSB property on their premises at their own cost.

Checked By

Authorized By

For all queries related to this order contact
www.rsbglobal.com

CORPORATE OFFICE: Ubale Nagar, Nagar Road, Wagoli, Pune, 412207, Tel : 91 20 30642100 Fax : 91 20 30642101



PURCHASE ORDER

Principal Place of Business/Bill To					Supply To						
RSB Transmissions (I) Ltd. (Forging Plant) Plot no. 1007, 1011 P.O. Uchapada Tel : 91674-2550590 Fax : 91674-2550590 Email : ranjan.jena@rsbglobal.com Website : www.rsbglobal.com GSTIN : 21AABCR3925R1Z5 PAN : AABCR3925R State Code & State : 21 ODISHA CIN : U34102PN1989PLC014807					RSB TRANSMISSIONS (I) LTD.(Cuttack) CUTTACK UNIT -1, NH-5,PLOT NO.1011,1007 MANIA,KOTSAHI,TANGI,CHOUDWAR 754022 Tel : 91674-2550590 Fax : 91674-2550590 Email : ranjan.jena@rsbglobal.com Website : www.rsbglobal.com GSTIN : 21AABCR3925R1Z5 PAN : AABCR3925R State Code & State : 21 ODISHA CIN : U34102PN1989PLC014807						
Supplier Details					PO Details						
Supplier Code : 40007025 Name : GRAMTARANG EMPLOYABILITY TRNG SERV P LTD Address : C/O ? CENTURION UNIVERSITY GRAM TARANG EMPLOYABILITY TRAINING SERVICES, AT- RAMACHANDRAPUR,JATANI , BHUBANESWAR Tel : Email : subratkumar.swain@gramtarang.org.in GSTIN : 21AABCC9406C1ZB PAN :AABCC9406C State Code & State : 21 ODISHA					Order Type/Order No : O2 / 18000262 Order Date : 11/01/18 Revision No/ Date : 0 / 11/01/18 Quotation No/ Date : Our Reference No. : Original Order No. : Validity Date : 02/01/19						
No.	Item Code	Drawing No.	HSN	Quantity	Rate	GST Amount/Percentage			Request Date	Amount	
	Description	Mod No:	SAC	UOM	Currency	IGST	CGST	SGST		(Qty x Rate)	
1	ZMRS0069 MACHINING CHARGES OF 1ST LINE ROUND CLAMP		998331	6.000 EA	5256.00 INR		2838.24 @ 9.0 %	2838.24 @ 9.0 %	11/01/18	31536.00	
2	ZMRS0069 MACHINING CHARGES OF 2ND LINE RECTANGULAR CLAMP		998331	6.000 EA	5940.00 INR		3207.60 @ 9.0 %	3207.60 @ 9.0 %	11/01/18	35640.00	
									Total :	67176.00	
									Packing & Forwarding Charges		
									CGST Input@9%	6045.84	
									SGST Input@9%	6045.84	
									Suspense Account		
									Suspense Setoff Account		
									Grand Total :	79267.68	
Grand Total (In Words) : Rupees Seventy Nine Thousand Two Hundred Sixty Seven and paise Sixty Eight Only. Delivery Terms : EX-WORKS.. Remarks : Payment Terms : 30 Days From Acceptance											

Checked By

Authorized By

For all queries related to this order contact
www.rsbglobal.com

CORPORATE OFFICE: Ubale Nagar, Nagar Road, Wagoli, Pune, 412207, Tel : 91 20 30642100 Fax : 91 20 30642101

TERMS & CONDITIONS**GENERAL**

1. Written acceptance of this PO or Commencement of supply/service against this PO shall constitute acceptance of this Purchase Order.
2. Delivery Challan/Invoice in duplicate should accompany all supplies made mentioning in there clearly supplier code, drawing no., part no., description of material PO no. specified in Purchase/subcontract & quantity supplied.
3. In the case of excisable goods transporter's copy should be send along with material otherwise bill/invoice will be held up. Failure to comply with this & consequent loss of mod vat credit on account of excise duty will be debited to your account where document are routed through bank send the transporter copy along with consent & enclose copy of invoice with document routed through bank. Attested/certified/Photostat copies of transporter's copy of invoice are not acceptable at all.
4. In case of subcontract item with our material failure to supply or return the material within 90 days under rule 4(5)(a) of central excise the excise duty payable in then will be debited to your account.
5. All drawings samples or technical data supplied to you by us shall be kept as secret & shall not be sold or disclosed & these shall be returned to as & when demanded. Failure to comply with this shall make you liable for breach of trust & other actions as may be deemed fit by us.
6. The items manufactured by you from the date furnished by us must not be sold or divulged by you to any other party than ourselves. If you manufacture excess quantity than our order you shall preserve the same for ultimate sale to us on our demand. Alternatively you destroy the goods so manufactured by you. By no account you will sell goods to any other party except with our written consent. The same condition applies to supplies rejected by us parts similar to parts manufactured for us; should not be manufactured by you.
7. No upward revision of price will be permitted during the period of contract unless agreed by us.
8. Terms & condition stated in our purchase/subcontract will be final until the supplier has our written consent to his terms & conditions if any stated in his order acceptance letter.
9. Any letter sent by prepaid registered post to the address given in this order shall be deemed to have been received by party within 3 days of dispatch thereof; irrespective of fact whether the said letter is or is not in fact received by party so addressed.
10. The company reserves the right to cancel & terminate the contract. If prevented by any intervention or control by government authorities or any other cause beyond the control of the company where by company is unable to make use the materials ordered by stoppage suspension of production or otherwise.
11. Local civil court shall have the jurisdiction to try any dispute concerning all our purchase/subcontract.
12. The material should be properly packed to avoid any kind of damage or formation of rust during transportation or storage.
13. Strict adherence to terms of delivery is absolutely essential. The company reserves the right to treat the order as cancelled in the event of your non-compliance of delivery schedule agreed & material will be brought from open market at your risk & cost. Time of delivery shall be essence of contract.
14. Demurrage, penalties etc. shall be levied on account of delay in delivery, dispatch or railway/lorry receipts, advance of invoice & challans or any other shipping documents or for any other reason for which the company is not responsible will be to the supplier's account & recoverable from him.
15. The material must be dispatched by the mode or transport & to the destination mentioned in this order. In case partial suppliers our prior approval must be obtained.
16. If transport arrangement is made by RSB for collection & dispatch of components it will be totally the supplier's risk RSB is not responsible for any shortages damages in such Arrangement supplier should send their representative with each consignment for collection & delivery to ensure safe transit of material.
17. Supplier shall give advance information to buyer in writing for all specification change design changes as well as major changes in processing location of manufacturing applying to goods covered by this Purchase order.
18. All vehicles used for transportation of material should comply to the central motor & vehicle rules act as applicable from time to time. The transporter is required to carry PUC vehicle fitness certificate of transportation vehicle during delivery.
19. Supplier should inform dispatch details immediately after dispatch.
20. Material supplied by seller shall satisfy current Govt. & environmental (ISO 14001-2004) & safety (OHSAS-18001-2007) constraints on restricted toxic & hazardous materials.
21. Supplier shall ensure coverage of transit insurance for material.
22. Supplier shall protect the third party trade secret or proprietary information for material or copy rights supplied by RSB. Failure to do so will result in PO being cancelled with immediate effect.

PAYMENT

1. Payment will be made as stipulated in this order, if the payment is agreed to be made against document through Bank. All bank charges involved shall be borne by the Supplier. Failure by the Supplier to advice his banker to recover all bank charges from supplier. Will result is non-retirement of documents at his own risk and cost.
2. All payments will be done as per applicable RSB policies.
3. No charges for cartage, packing etc., will admissible unless the same is specifically included in our Purchase/ Sub Contract.

SUPPLIER'S QUALITY ASSURANCE

1. All the materials, Component supplied must critically meet RSB Quality standards required as per samples, drawings, specifications or any other related instructions. The supplier shall allow, RSB's employee and authorized representatives for the purpose of inspecting manufacturing and inspection facilities, inspection of raw materials, WIP, FG, machines tools, fixtures jigs or any other items in connection with the manufacture of components for the company.

SAMPLE APPROVAL

1. No supplies should be made prior to the approval of sample unless specifically asked by us. It shall be the responsibility of the Supplier to submit samples well in time to be able to adhere strictly to the delivery schedule.

REJECTIONS

1. The decisions of the company on rejection shall be final and binding on the Supplier and this time clause shall be deemed to constitute an agreement to the contrary under the Sale of Goods Act. The company shall be entitled to reject the materials at any stage, cancel the contract and buy its requirements in the open market against the supplies. There is no rejection allowed unless specifically mentioned in the P.O. clearly.
2. It will be the liability of the Supplier to remove the rejected material within 15 days from our premises at his cost. In case rejection is not taken back within 15 days RSB is not liable to return back the rejection & no compensation will be given. In case of any rework done the components supplied by the suppliers, rework charges, handling charges, disposal charges & any other related charges as applicable will be recovered from Supplier's bill.
3. Rejection must be replaced within the delivery schedule and will be invoiced separately and not as replacement. All charges inclusive of freight and handling on replacements shall be borne by the Supplier.

WARRANTY

1. All the material supplied, should be free from any manufacturing, process defects & should be as per the drawings, Specifications. Any failure at RSB's customer end due to any deviation on quality, supplier shall be responsible for all damages, claims, recovery directly or indirectly claimed to RSB by any agency. Supplier shall reimburse all such expenses to RSB immediately without any delay on any ground. It will be the responsibility of the supplier to provide free replacement of component & assemblies which fail in the field because of material or manufacturing defects during the Warranty period or during the product life cycle, any offered by the company to its customers.

IN THE CASE OF SUB CONTRACT

1. Material Account to be submitted every month with regards to the Receipts & Supply in the prescribed format.
2. The supplier is responsible for safe custody of Company's material including the RAW Material/ Semi Finished/Finished/Tooling.
3. Periodic Physical Verification will be carried out by company's representative. During which supplier should assist in such verification.
4. The supplier has to obtain in writing the quantum to be consumed for each item supplied to him.
5. Supplier is fully responsible for quantity lifted by him till the entire quantity is supplied by him as per specification.
6. The supplier should also return the resultant scrap generated during machining. The remaining material/semi finished/finished held by supplier shall be property of company & company reserves the right to seek for return of raw material in which event the supplier shall return the same forth with.
7. No process rejection is allowed unless specified in PO specifically. In case process rejection, rejected component should be returned back to RSB on a separate delivery challan. All such components should be marked with red paint & to be supplied in a separate batch to avoid mix up. Process rejection exceeding allowed rejection % full cost of raw material shall be recovered. Line rejection at RSB is not considered in the allowed process rejection (if any). Line rejection will be recovered at full cost & rejected components will not be returned back or no scrap benefit will be passed on to supplier.
8. Supplier should ensure coverage of insurance of RSB property on their premises at their own cost.

Checked By

Authorized By

For all queries related to this order contact
www.rsbglobal.com

CORPORATE OFFICE: Ubale Nagar, Nagar Road, Wagoli, Pune, 412207, Tel : 91 20 30642100 Fax : 91 20 30642101



PURCHASE ORDER

Principal Place of Business/Bill To					Supply To					
RSB Transmissions (I) Ltd. (Forging Plant) Plot no. 1007, 1011 P.O. Uchapada Tel : 91674-2550590 Fax : 91674-2550590 Email : ranjan.jena@rsbglobal.com Website : www.rsbglobal.com GSTIN : 21AABCR3925R1Z5 PAN : AABCR3925R State Code & State : 21 ODISHA CIN : U34102PN1989PLC014807					RSB TRANSMISSIONS (I) LTD.(Cuttack) CUTTACK UNIT -1, NH-5,PLOT NO.1011,1007 MANIA,KOTSAHI,TANGI,CHOUDWAR 754022 Tel : 91674-2550590 Fax : 91674-2550590 Email : ranjan.jena@rsbglobal.com Website : www.rsbglobal.com GSTIN : 21AABCR3925R1Z5 PAN : AABCR3925R State Code & State : 21 ODISHA CIN : U34102PN1989PLC014807					
Supplier Details					PO Details					
Supplier Code : 40007025 Name : GRAMTARANG EMPLOYABILITY TRNG SERV P LTD Address : C/O ? CENTURION UNIVERSITY GRAM TARANG EMPLOYABILITY TRAINING SERVICES, AT- RAMACHANDRAPUR,JATANI , BHUBANESWAR Tel : Email : subratkumar.swain@gramtarang.org.in GSTIN : 21AABCC9406C1ZB PAN :AABCC9406C State Code & State : 21 ODISHA					Order Type/Order No : OS / 18000043 Order Date : 12/25/18 Revision No/ Date : 0 / 12/25/18 Quotation No/ Date : Our Reference No. : AS PER CAM SHEET Original Order No. : Validity Date : 03/30/19					
No.	Item Code	Drawing No.	HSN	Quantity	Rate	GST Amount/Percentage			Request Date	Amount
	Description	Mod No:	SAC	UOM	Currency	IGST	CGST	SGST		(Qty x Rate)
1	PBBD1225*OP10 BLOCKER BOTTOM D1225		40092200	1.000 EA	10944.00 INR		984.96 @ 9.0 %	984.96 @ 9.0 %	12/25/18	10944.00
2	PFTD1225*OP10 FINISHER TOP D1225		40092200	1.000 EA	11952.00 INR		1075.68 @ 9.0 %	1075.68 @ 9.0 %	12/25/18	11952.00
							Total :			22896.00
							CGST Input@9%			2060.64
							SGST Input@9%			2060.64
							Other			
							Suspense Account			
							Suspense Setoff Account			
							Grand Total :			27017.28
Grand Total (In Words) : Rupees Twenty Seven Thousand Seventeen and paise Twenty Eight Only. Delivery Terms : EX-WORKS. Remarks : Payment Terms : 30 Days From Acceptance										

Checked By

Authorized By

For all queries related to this order contact
www.rsbglobal.com

CORPORATE OFFICE: Ubale Nagar, Nagar Road, Wagoli, Pune, 412207, Tel : 91 20 30642100 Fax : 91 20 30642101

TERMS & CONDITIONS**GENERAL**

1. Written acceptance of this PO or Commencement of supply/service against this PO shall constitute acceptance of this Purchase Order.
2. Delivery Challan/Invoice in duplicate should accompany all supplies made mentioning in there clearly supplier code, drawing no., part no., description of material PO no. specified in Purchase/subcontract & quantity supplied.
3. In the case of excisable goods transporter's copy should be send along with material otherwise bill/invoice will be held up. Failure to comply with this & consequent loss of mod vat credit on account of excise duty will be debited to your account where document are routed through bank send the transporter copy along with consent & enclose copy of invoice with document routed through bank. Attested/certified/Photostat copies of transporter's copy of invoice are not acceptable at all.
4. In case of subcontract item with our material failure to supply or return the material within 90 days under rule 4(5)(a) of central excise the excise duty payable in then will be debited to your account.
5. All drawings samples or technical data supplied to you by us shall be kept as secret & shall not be sold or disclosed & these shall be returned to as & when demanded. Failure to comply with this shall make you liable for breach of trust & other actions as may be deemed fit by us.
6. The items manufactured by you from the date furnished by us must not be sold or divulged by you to any other party than ourselves. If you manufacture excess quantity than our order you shall preserve the same for ultimate sale to us on our demand. Alternatively you destroy the goods so manufactured by you. By no account you will sell goods to any other party except with our written consent. The same condition applies to supplies rejected by us parts similar to parts manufactured for us; should not be manufactured by you.
7. No upward revision of price will be permitted during the period of contract unless agreed by us.
8. Terms & condition stated in our purchase/subcontract will be final until the supplier has our written consent to his terms & conditions if any stated in his order acceptance letter.
9. Any letter sent by prepaid registered post to the address given in this order shall be deemed to have been received by party within 3 days of dispatch thereof; irrespective of fact whether the said letter is or is not in fact received by party so addressed.
10. The company reserves the right to cancel & terminate the contract. If prevented by any intervention or control by government authorities or any other cause beyond the control of the company where by company is unable to make use the materials ordered by stoppage suspension of production or otherwise.
11. Local civil court shall have the jurisdiction to try any dispute concerning all our purchase/subcontract.
12. The material should be properly packed to avoid any kind of damage or formation of rust during transportation or storage.
13. Strict adherence to terms of delivery is absolutely essential. The company reserves the right to treat the order as cancelled in the event of your non-compliance of delivery schedule agreed & material will be brought from open market at your risk & cost. Time of delivery shall be essence of contract.
14. Demurrage, penalties etc. shall be levied on account of delay in delivery, dispatch or railway/lorry receipts, advance of invoice & challans or any other shipping documents or for any other reason for which the company is not responsible will be to the supplier's account & recoverable from him.
15. The material must be dispatched by the mode or transport & to the destination mentioned in this order. In case partial suppliers our prior approval must be obtained.
16. If transport arrangement is made by RSB for collection & dispatch of components it will be totally the supplier's risk RSB is not responsible for any shortages damages in such Arrangement supplier should send their representative with each consignment for collection & delivery to ensure safe transit of material.
17. Supplier shall give advance information to buyer in writing for all specification change design changes as well as major changes in processing location of manufacturing applying to goods covered by this Purchase order.
18. All vehicles used for transportation of material should comply to the central motor & vehicle rules act as applicable from time to time. The transporter is required to carry PUC vehicle fitness certificate of transportation vehicle during delivery.
19. Supplier should inform dispatch details immediately after dispatch.
20. Material supplied by seller shall satisfy current Govt. & environmental (ISO 14001-2004) & safety (OHSAS-18001-2007) constraints on restricted toxic & hazardous materials.
21. Supplier shall ensure coverage of transit insurance for material.
22. Supplier shall protect the third party trade secret or proprietary information for material or copy rights supplied by RSB. Failure to do so will result in PO being cancelled with immediate effect.

PAYMENT

1. Payment will be made as stipulated in this order, if the payment is agreed to be made against document through Bank. All bank charges involved shall be borne by the Supplier. Failure by the Supplier to advice his banker to recover all bank charges from supplier. Will result is non-retirement of documents at his own risk and cost.
2. All payments will be done as per applicable RSB policies.
3. No charges for cartage, packing etc., will admissible unless the same is specifically included in our Purchase/ Sub Contract.

SUPPLIER'S QUALITY ASSURANCE

1. All the materials, Component supplied must critically meet RSB Quality standards required as per samples, drawings, specifications or any other related instructions. The supplier shall allow, RSB's employee and authorized representatives for the purpose of inspecting manufacturing and inspection facilities, inspection of raw materials, WIP, FG, machines tools, fixtures jigs or any other items in connection with the manufacture of components for the company.

SAMPLE APPROVAL

1. No supplies should be made prior to the approval of sample unless specifically asked by us. It shall be the responsibility of the Supplier to submit samples well in time to be able to adhere strictly to the delivery schedule.

REJECTIONS

1. The decisions of the company on rejection shall be final and binding on the Supplier and this time clause shall be deemed to constitute an agreement to the contrary under the Sale of Goods Act. The company shall be entitled to reject the materials at any stage, cancel the contract and buy its requirements in the open market against the supplies. There is no rejection allowed unless specifically mentioned in the P.O. clearly.
2. It will be the liability of the Supplier to remove the rejected material within 15 days from our premises at his cost. In case rejection is not taken back within 15 days RSB is not liable to return back the rejection & no compensation will be given. In case of any rework done the components supplied by the suppliers, rework charges, handling charges, disposal charges & any other related charges as applicable will be recovered from Supplier's bill.
3. Rejection must be replaced within the delivery schedule and will be invoiced separately and not as replacement. All charges inclusive of freight and handling on replacements shall be borne by the Supplier.

WARRANTY

1. All the material supplied, should be free from any manufacturing, process defects & should be as per the drawings, Specifications. Any failure at RSB's customer end due to any deviation on quality, supplier shall be responsible for all damages, claims, recovery directly or indirectly claimed to RSB by any agency. Supplier shall reimburse all such expenses to RSB immediately without any delay on any ground. It will be the responsibility of the supplier to provide free replacement of component & assemblies which fail in the field because of material or manufacturing defects during the Warranty period or during the product life cycle, any offered by the company to its customers.

IN THE CASE OF SUB CONTRACT

1. Material Account to be submitted every month with regards to the Receipts & Supply in the prescribed format.
2. The supplier is responsible for safe custody of Company's material including the RAW Material/ Semi Finished/Finished/Tooling.
3. Periodic Physical Verification will be carried out by company's representative. During which supplier should assist in such verification.
4. The supplier has to obtain in writing the quantum to be consumed for each item supplied to him.
5. Supplier is fully responsible for quantity lifted by him till the entire quantity is supplied by him as per specification.
6. The supplier should also return the resultant scrap generated during machining. The remaining material/semi finished/finished held by supplier shall be property of company & company reserves the right to seek for return of raw material in which event the supplier shall return the same forth with.
7. No process rejection is allowed unless specified in PO specifically. In case process rejection, rejected component should be returned back to RSB on a separate delivery challan. All such components should be marked with red paint & to be supplied in a separate batch to avoid mix up. Process rejection exceeding allowed rejection % full cost of raw material shall be recovered. Line rejection at RSB is not considered in the allowed process rejection (if any). Line rejection will be recovered at full cost & rejected components will not be returned back or no scrap benefit will be passed on to supplier.
8. Supplier should ensure coverage of insurance of RSB property on their premises at their own cost.

Checked By

Authorized By

For all queries related to this order contact
www.rsbglobal.com

CORPORATE OFFICE: Ubale Nagar, Nagar Road, Wagoli, Pune, 412207, Tel : 91 20 30642100 Fax : 91 20 30642101



PURCHASE ORDER

Principal Place of Business/Bill To					Supply To					
RSB Transmissions (I) Ltd. (Forging Plant) Plot no. 1007, 1011 P.O. Uchapada Tel : 91674-2550590 Fax : 91674-2550590 Email : ranjan.jena@rsbglobal.com Website : www.rsbglobal.com GSTIN : 21AABCR3925R1Z5 PAN : AABCR3925R State Code & State : 21 ODISHA CIN : U34102PN1989PLC014807					RSB TRANSMISSIONS (I) LTD.(Cuttack) CUTTACK UNIT -1, NH-5,PLOT NO.1011,1007 MANIA,KOTSAHI,TANGI,CHOUDWAR 754022 Tel : 91674-2550590 Fax : 91674-2550590 Email : ranjan.jena@rsbglobal.com Website : www.rsbglobal.com GSTIN : 21AABCR3925R1Z5 PAN : AABCR3925R State Code & State : 21 ODISHA CIN : U34102PN1989PLC014807					
Supplier Details					PO Details					
Supplier Code : 40007025 Name : GRAMTARANG EMPLOYABILITY TRNG SERV P LTD Address : C/O ? CENTURION UNIVERSITY GRAM TARANG EMPLOYABILITY TRAINING SERVICES, AT- RAMACHANDRAPUR,JATANI , BHUBANESWAR Tel : Email : subratkumar.swain@gramtarang.org.in GSTIN : 21AABCC9406C1ZB PAN :AABCC9406C State Code & State : 21 ODISHA					Order Type/Order No : O2 / 18000304 Order Date : 12/04/18 Revision No/ Date : 0 / 12/04/18 Quotation No/ Date : Our Reference No. : Original Order No. : Validity Date : 03/04/19					
No.	Item Code	Drawing No.	HSN	Quantity	Rate	GST Amount/Percentage			Request Date	Amount (Qty x Rate)
	Description	Mod No:	SAC	UOM	Currency	IGST	CGST	SGST		
1	ZMRS0069 MACHINING CHARGES OF WELDED DIE 1203L FIN. BOTTOM		998331	1.000 EA	4428.00 INR		398.52 @ 9.0 %	398.52 @ 9.0 %	12/04/18	4428.00
2	ZMRS0069 MACHINING CHARGES OF WELDED DIE 1203L FIN. TOP		998331	1.000 EA	6372.00 INR		573.48 @ 9.0 %	573.48 @ 9.0 %	12/04/18	6372.00
								Total :	10800.00	
								Packing & Forwarding Charges		
								CGST Input@9%	972.00	
								SGST Input@9%	972.00	
								Suspense Account		
								Suspense Setoff Account		
								Grand Total :	12744.00	
Grand Total (In Words) : Rupees Twelve Thousand Seven Hundred Forty Four Only. Delivery Terms : Remarks : Payment Terms : 30 Days From Acceptance										

Checked By

Authorized By

TERMS & CONDITIONS**GENERAL**

1. Written acceptance of this PO or Commencement of supply/service against this PO shall constitute acceptance of this Purchase Order.
2. Delivery Challan/Invoice in duplicate should accompany all supplies made mentioning in there clearly supplier code, drawing no., part no., description of material PO no. specified in Purchase/subcontract & quantity supplied.
3. In the case of excisable goods transporter's copy should be send along with material otherwise bill/invoice will be held up. Failure to comply with this & consequent loss of mod vat credit on account of excise duty will be debited to your account where document are routed through bank send the transporter copy along with consent & enclose copy of invoice with document routed through bank. Attested/certified/Photostat copies of transporter's copy of invoice are not acceptable at all.
4. In case of subcontract item with our material failure to supply or return the material within 90 days under rule 4(5)(a) of central excise the excise duty payable in then will be debited to your account.
5. All drawings samples or technical data supplied to you by us shall be kept as secret & shall not be sold or disclosed & these shall be returned to as & when demanded. Failure to comply with this shall make you liable for breach of trust & other actions as may be deemed fit by us.
6. The items manufactured by you from the date furnished by us must not be sold or divulged by you to any other party than ourselves. If you manufacture excess quantity than our order you shall preserve the same for ultimate sale to us on our demand. Alternatively you destroy the goods so manufactured by you. By no account you will sell goods to any other party except with our written consent. The same condition applies to supplies rejected by us parts similar to parts manufactured for us; should not be manufactured by you.
7. No upward revision of price will be permitted during the period of contract unless agreed by us.
8. Terms & condition stated in our purchase/subcontract will be final until the supplier has our written consent to his terms & conditions if any stated in his order acceptance letter.
9. Any letter sent by prepaid registered post to the address given in this order shall be deemed to have been received by party within 3 days of dispatch thereof; irrespective of fact whether the said letter is or is not in fact received by party so addressed.
10. The company reserves the right to cancel & terminate the contract. If prevented by any intervention or control by government authorities or any other cause beyond the control of the company where by company is unable to make use the materials ordered by stoppage suspension of production or otherwise.
11. Local civil court shall have the jurisdiction to try any dispute concerning all our purchase/subcontract.
12. The material should be properly packed to avoid any kind of damage or formation of rust during transportation or storage.
13. Strict adherence to terms of delivery is absolutely essential. The company reserves the right to treat the order as cancelled in the event of your non-compliance of delivery schedule agreed & material will be brought from open market at your risk & cost. Time of delivery shall be essence of contract.
14. Demurrage, penalties etc. shall be levied on account of delay in delivery, dispatch or railway/lorry receipts, advance of invoice & challans or any other shipping documents or for any other reason for which the company is not responsible will be to the supplier's account & recoverable from him.
15. The material must be dispatched by the mode or transport & to the destination mentioned in this order. In case partial suppliers our prior approval must be obtained.
16. If transport arrangement is made by RSB for collection & dispatch of components it will be totally the supplier's risk RSB is not responsible for any shortages damages in such Arrangement supplier should send their representative with each consignment for collection & delivery to ensure safe transit of material.
17. Supplier shall give advance information to buyer in writing for all specification change design changes as well as major changes in processing location of manufacturing applying to goods covered by this Purchase order.
18. All vehicles used for transportation of material should comply to the central motor & vehicle rules act as applicable from time to time. The transporter is required to carry PUC vehicle fitness certificate of transportation vehicle during delivery.
19. Supplier should inform dispatch details immediately after dispatch.
20. Material supplied by seller shall satisfy current Govt. & environmental (ISO 14001-2004) & safety (OHSAS-18001-2007) constraints on restricted toxic & hazardous materials.
21. Supplier shall ensure coverage of transit insurance for material.
22. Supplier shall protect the third party trade secret or proprietary information for material or copy rights supplied by RSB. Failure to do so will result in PO being cancelled with immediate effect.

PAYMENT

1. Payment will be made as stipulated in this order, if the payment is agreed to be made against document through Bank. All bank charges involved shall be borne by the Supplier. Failure by the Supplier to advice his banker to recover all bank charges from supplier. Will result is non-retirement of documents at his own risk and cost.
2. All payments will be done as per applicable RSB policies.
3. No charges for cartage, packing etc., will admissible unless the same is specifically included in our Purchase/ Sub Contract.

SUPPLIER'S QUALITY ASSURANCE

1. All the materials, Component supplied must critically meet RSB Quality standards required as per samples, drawings, specifications or any other related instructions. The supplier shall allow, RSB's employee and authorized representatives for the purpose of inspecting manufacturing and inspection facilities, inspection of raw materials, WIP, FG, machines tools, fixtures jigs or any other items in connection with the manufacture of components for the company.

SAMPLE APPROVAL

1. No supplies should be made prior to the approval of sample unless specifically asked by us. It shall be the responsibility of the Supplier to submit samples well in time to be able to adhere strictly to the delivery schedule.

REJECTIONS

1. The decisions of the company on rejection shall be final and binding on the Supplier and this time clause shall be deemed to constitute an agreement to the contrary under the Sale of Goods Act. The company shall be entitled to reject the materials at any stage, cancel the contract and buy its requirements in the open market against the supplies. There is no rejection allowed unless specifically mentioned in the P.O. clearly.
2. It will be the liability of the Supplier to remove the rejected material within 15 days from our premises at his cost. In case rejection is not taken back within 15 days RSB is not liable to return back the rejection & no compensation will be given. In case of any rework done the components supplied by the suppliers, rework charges, handling charges, disposal charges & any other related charges as applicable will be recovered from Supplier's bill.
3. Rejection must be replaced within the delivery schedule and will be invoiced separately and not as replacement. All charges inclusive of freight and handling on replacements shall be borne by the Supplier.

WARRANTY

1. All the material supplied, should be free from any manufacturing, process defects & should be as per the drawings, Specifications. Any failure at RSB's customer end due to any deviation on quality, supplier shall be responsible for all damages, claims, recovery directly or indirectly claimed to RSB by any agency. Supplier shall reimburse all such expenses to RSB immediately without any delay on any ground. It will be the responsibility of the supplier to provide free replacement of component & assemblies which fail in the field because of material or manufacturing defects during the Warranty period or during the product life cycle, any offered by the company to its customers.

IN THE CASE OF SUB CONTRACT

1. Material Account to be submitted every month with regards to the Receipts & Supply in the prescribed format.
2. The supplier is responsible for safe custody of Company's material including the RAW Material/ Semi Finished/Finished/Tooling.
3. Periodic Physical Verification will be carried out by company's representative. During which supplier should assist in such verification.
4. The supplier has to obtain in writing the quantum to be consumed for each item supplied to him.
5. Supplier is fully responsible for quantity lifted by him till the entire quantity is supplied by him as per specification.
6. The supplier should also return the resultant scrap generated during machining. The remaining material/semi finished/finished held by supplier shall be property of company & company reserves the right to seek for return of raw material in which event the supplier shall return the same forth with.
7. No process rejection is allowed unless specified in PO specifically. In case process rejection, rejected component should be returned back to RSB on a separate delivery challan. All such components should be marked with red paint & to be supplied in a separate batch to avoid mix up. Process rejection exceeding allowed rejection % full cost of raw material shall be recovered. Line rejection at RSB is not considered in the allowed process rejection (if any). Line rejection will be recovered at full cost & rejected components will not be returned back or no scrap benefit will be passed on to supplier.
8. Supplier should ensure coverage of insurance of RSB property on their premises at their own cost.

Checked By

Authorized By

For all queries related to this order contact
www.rsbglobal.com

CORPORATE OFFICE: Ubale Nagar, Nagar Road, Wagoli, Pune, 412207, Tel : 91 20 30642100 Fax : 91 20 30642101



PURCHASE ORDER

Principal Place of Business/Bill To					Supply To						
RSB Transmissions (I) Ltd. (Forging Plant) Plot no. 1007, 1011 P.O. Uchapada Tel : 91674-2550590 Fax : 91674-2550590 Email : ranjan.jena@rsbglobal.com Website : www.rsbglobal.com GSTIN : 21AABCR3925R1Z5 PAN : AABCR3925R State Code & State : 21 ODISHA CIN : U34102PN1989PLC014807					RSB TRANSMISSIONS (I) LTD.(Cuttack) CUTTACK UNIT -1, NH-5,PLOT NO.1011,1007 MANIA,KOTSAHI,TANGI,CHOUDWAR 754022 Tel : 91674-2550590 Fax : 91674-2550590 Email : ranjan.jena@rsbglobal.com Website : www.rsbglobal.com GSTIN : 21AABCR3925R1Z5 PAN : AABCR3925R State Code & State : 21 ODISHA CIN : U34102PN1989PLC014807						
Supplier Details					PO Details						
Supplier Code : 40007025 Name : GRAMTARANG EMPLOYABILITY TRNG SERV P LTD Address : C/O ? CENTURION UNIVERSITY GRAM TARANG EMPLOYABILITY TRAINING SERVICES, AT- RAMACHANDRAPUR,JATANI , BHUBANESWAR Tel : Email : subratkumar.swain@gramtarang.org.in GSTIN : 21AABCC9406C1ZB PAN : AABCC9406C State Code & State : 21 ODISHA					Order Type/Order No : O2 / 18000354 Order Date : 01/10/19 Revision No/ Date : 0 / 01/10/19 Quotation No/ Date : Our Reference No. : Original Order No. : Validity Date : 03/10/19						
No.	Item Code	Drawing No.	HSN	Quantity	Rate	GST Amount/Percentage			Request Date	Amount (Qty x Rate)	
	Description	Mod No:	SAC	UOM	Currency	IGST	CGST	SGST			
1	ZMRS0069 MACHINING CHARGES OF WELDED DIE 1201 BLOCKER TOP		998331	1.000 EA	3024.00 INR		272.16 @ 9.0 %	272.16 @ 9.0 %	01/10/19	3024.00	
2	ZMRS0069 MACHINING CHARGES OF WELDED DIE 1201 FINISHER TOP		998331	1.000 EA	4248.00 INR		382.32 @ 9.0 %	382.32 @ 9.0 %	01/10/19	4248.00	
3	ZMRS0069 MACHINING CHARGES OF WELDED DIE 1201 FINISHER BOTTOM		998331	1.000 EA	3096.00 INR		278.64 @ 9.0 %	278.64 @ 9.0 %	01/10/19	3096.00	
4	ZMRS0069 MACHINING CHARGES OF WELDED DIE 1201 BLOCKER BOTTOM		998331	1.000 EA	4428.00 INR		398.52 @ 9.0 %	398.52 @ 9.0 %	01/10/19	4428.00	
									Total :	14796.00	
									Packing & Forwarding Charges		
									CGST Input@9%	1331.64	
									SGST Input@9%	1331.64	
									Suspense Account		
									Suspense Setoff Account		
									Grand Total :	17459.28	
Grand Total (In Words) : Rupees Seventeen Thousand Four Hundred Fifty Nine and paise Twenty Eight Only.											
Delivery Terms : Remarks : Payment Terms : 30 Days From Acceptance											

Checked By

Authorized By

For all queries related to this order contact
www.rsbglobal.com

CORPORATE OFFICE: Ubale Nagar, Nagar Road, Wagoli, Pune, 412207, Tel : 91 20 30642100 Fax : 91 20 30642101

TERMS & CONDITIONS**GENERAL**

1. Written acceptance of this PO or Commencement of supply/service against this PO shall constitute acceptance of this Purchase Order.
2. Delivery Challan/Invoice in duplicate should accompany all supplies made mentioning in there clearly supplier code, drawing no., part no., description of material PO no. specified in Purchase/subcontract & quantity supplied.
3. In the case of excisable goods transporter's copy should be send along with material otherwise bill/invoice will be held up. Failure to comply with this & consequent loss of mod vat credit on account of excise duty will be debited to your account where document are routed through bank send the transporter copy along with consent & enclose copy of invoice with document routed through bank. Attested/certified/Photostat copies of transporter's copy of invoice are not acceptable at all.
4. In case of subcontract item with our material failure to supply or return the material within 90 days under rule 4(5)(a) of central excise the excise duty payable in then will be debited to your account.
5. All drawings samples or technical data supplied to you by us shall be kept as secret & shall not be sold or disclosed & these shall be returned to as & when demanded. Failure to comply with this shall make you liable for breach of trust & other actions as may be deemed fit by us.
6. The items manufactured by you from the date furnished by us must not be sold or divulged by you to any other party than ourselves. If you manufacture excess quantity than our order you shall preserve the same for ultimate sale to us on our demand. Alternatively you destroy the goods so manufactured by you. By no account you will sell goods to any other party except with our written consent. The same condition applies to supplies rejected by us parts similar to parts manufactured for us; should not be manufactured by you.
7. No upward revision of price will be permitted during the period of contract unless agreed by us.
8. Terms & condition stated in our purchase/subcontract will be final until the supplier has our written consent to his terms & conditions if any stated in his order acceptance letter.
9. Any letter sent by prepaid registered post to the address given in this order shall be deemed to have been received by party within 3 days of dispatch thereof; irrespective of fact whether the said letter is or is not in fact received by party so addressed.
10. The company reserves the right to cancel & terminate the contract. If prevented by any intervention or control by government authorities or any other cause beyond the control of the company where by company is unable to make use the materials ordered by stoppage suspension of production or otherwise.
11. Local civil court shall have the jurisdiction to try any dispute concerning all our purchase/subcontract.
12. The material should be properly packed to avoid any kind of damage or formation of rust during transportation or storage.
13. Strict adherence to terms of delivery is absolutely essential. The company reserves the right to treat the order as cancelled in the event of your non-compliance of delivery schedule agreed & material will be brought from open market at your risk & cost. Time of delivery shall be essence of contract.
14. Demurrage, penalties etc. shall be levied on account of delay in delivery, dispatch or railway/lorry receipts, advance of invoice & challans or any other shipping documents or for any other reason for which the company is not responsible will be to the supplier's account & recoverable from him.
15. The material must be dispatched by the mode or transport & to the destination mentioned in this order. In case partial suppliers our prior approval must be obtained.
16. If transport arrangement is made by RSB for collection & dispatch of components it will be totally the supplier's risk RSB is not responsible for any shortages damages in such Arrangement supplier should send their representative with each consignment for collection & delivery to ensure safe transit of material.
17. Supplier shall give advance information to buyer in writing for all specification change design changes as well as major changes in processing location of manufacturing applying to goods covered by this Purchase order.
18. All vehicles used for transportation of material should comply to the central motor & vehicle rules act as applicable from time to time. The transporter is required to carry PUC vehicle fitness certificate of transportation vehicle during delivery.
19. Supplier should inform dispatch details immediately after dispatch.
20. Material supplied by seller shall satisfy current Govt. & environmental (ISO 14001-2004) & safety (OHSAS-18001-2007) constraints on restricted toxic & hazardous materials.
21. Supplier shall ensure coverage of transit insurance for material.
22. Supplier shall protect the third party trade secret or proprietary information for material or copy rights supplied by RSB. Failure to do so will result in PO being cancelled with immediate effect.

PAYMENT

1. Payment will be made as stipulated in this order, if the payment is agreed to be made against document through Bank. All bank charges involved shall be borne by the Supplier. Failure by the Supplier to advice his banker to recover all bank charges from supplier. Will result is non-retirement of documents at his own risk and cost.
2. All payments will be done as per applicable RSB policies.
3. No charges for cartage, packing etc., will admissible unless the same is specifically included in our Purchase/ Sub Contract.

SUPPLIER'S QUALITY ASSURANCE

1. All the materials, Component supplied must critically meet RSB Quality standards required as per samples, drawings, specifications or any other related instructions. The supplier shall allow, RSB's employee and authorized representatives for the purpose of inspecting manufacturing and inspection facilities, inspection of raw materials, WIP, FG, machines tools, fixtures jigs or any other items in connection with the manufacture of components for the company.

SAMPLE APPROVAL

1. No supplies should be made prior to the approval of sample unless specifically asked by us. It shall be the responsibility of the Supplier to submit samples well in time to be able to adhere strictly to the delivery schedule.

REJECTIONS

1. The decisions of the company on rejection shall be final and binding on the Supplier and this time clause shall be deemed to constitute an agreement to the contrary under the Sale of Goods Act. The company shall be entitled to reject the materials at any stage, cancel the contract and buy its requirements in the open market against the supplies. There is no rejection allowed unless specifically mentioned in the P.O. clearly.
2. It will be the liability of the Supplier to remove the rejected material within 15 days from our premises at his cost. In case rejection is not taken back within 15 days RSB is not liable to return back the rejection & no compensation will be given. In case of any rework done the components supplied by the suppliers, rework charges, handling charges, disposal charges & any other related charges as applicable will be recovered from Supplier's bill.
3. Rejection must be replaced within the delivery schedule and will be invoiced separately and not as replacement. All charges inclusive of freight and handling on replacements shall be borne by the Supplier.

WARRANTY

1. All the material supplied, should be free from any manufacturing, process defects & should be as per the drawings, Specifications. Any failure at RSB's customer end due to any deviation on quality, supplier shall be responsible for all damages, claims, recovery directly or indirectly claimed to RSB by any agency. Supplier shall reimburse all such expenses to RSB immediately without any delay on any ground. It will be the responsibility of the supplier to provide free replacement of component & assemblies which fail in the field because of material or manufacturing defects during the Warranty period or during the product life cycle, any offered by the company to its customers.

IN THE CASE OF SUB CONTRACT

1. Material Account to be submitted every month with regards to the Receipts & Supply in the prescribed format.
2. The supplier is responsible for safe custody of Company's material including the RAW Material/ Semi Finished/Finished/Tooling.
3. Periodic Physical Verification will be carried out by company's representative. During which supplier should assist in such verification.
4. The supplier has to obtain in writing the quantum to be consumed for each item supplied to him.
5. Supplier is fully responsible for quantity lifted by him till the entire quantity is supplied by him as per specification.
6. The supplier should also return the resultant scrap generated during machining. The remaining material/semi finished/finished held by supplier shall be property of company & company reserves the right to seek for return of raw material in which event the supplier shall return the same forth with.
7. No process rejection is allowed unless specified in PO specifically. In case process rejection, rejected component should be returned back to RSB on a separate delivery challan. All such components should be marked with red paint & to be supplied in a separate batch to avoid mix up. Process rejection exceeding allowed rejection % full cost of raw material shall be recovered. Line rejection at RSB is not considered in the allowed process rejection (if any). Line rejection will be recovered at full cost & rejected components will not be returned back or no scrap benefit will be passed on to supplier.
8. Supplier should ensure coverage of insurance of RSB property on their premises at their own cost.

Checked By

Authorized By

For all queries related to this order contact
www.rsbglobal.com

CORPORATE OFFICE: Ubale Nagar, Nagar Road, Wagoli, Pune, 412207, Tel : 91 20 30642100 Fax : 91 20 30642101



PURCHASE ORDER

Principal Place of Business/Bill To					Supply To						
RSB Transmissions (I) Ltd. (Forging Plant) Plot no. 1007, 1011 P.O. Uchapada Tel : 91674-2550590 Fax : 91674-2550590 Email : ranjan.jena@rsbglobal.com Website : www.rsbglobal.com GSTIN : 21AABCR3925R1Z5 PAN : AABCR3925R State Code & State : 21 ODISHA CIN : U34102PN1989PLC014807					RSB TRANSMISSIONS (I) LTD.(Cuttack) CUTTACK UNIT -1, NH-5,PLOT NO.1011,1007 MANIA,KOTSAHI,TANGI,CHOUDWAR 754022 Tel : 91674-2550590 Fax : 91674-2550590 Email : ranjan.jena@rsbglobal.com Website : www.rsbglobal.com GSTIN : 21AABCR3925R1Z5 PAN : AABCR3925R State Code & State : 21 ODISHA CIN : U34102PN1989PLC014807						
Supplier Details					PO Details						
Supplier Code : 40007025 Name : GRAMTARANG EMPLOYABILITY TRNG SERV P LTD Address : C/O ? CENTURION UNIVERSITY GRAM TARANG EMPLOYABILITY TRAINING SERVICES, AT- RAMACHANDRAPUR,JATANI , BHUBANESWAR Tel : Email : subratkumar.swain@gramtarang.org.in GSTIN : 21AABCC9406C1ZB PAN : AABCC9406C State Code & State : 21 ODISHA					Order Type/Order No : O2 / 18000396 Order Date : 13/02/2019 Revision No/ Date : 0 / 13/02/2019 Quotation No/ Date : Our Reference No. : Original Order No. : Validity Date : 31/03/2019						
No.	Item Code	Drawing No.	HSN	Quantity	Rate	GST Amount/Percentage			Request Date	Amount	
	Description	Mod No:	SAC	UOM	Currency	IGST	CGST	SGST		(Qty x Rate)	
1	ZMRS0069 MACHINING CHARGES OF WELDED DIE 1225 FIN TOP		998331	1.000 EA	6912.00 INR		622.08 @ 9.0 %	622.08 @ 9.0 %	02/13/19	6912.00	
2	ZMRS0069 MACHINING CHARGES OF WELDED DIE 1225 FIN BTM		998331	1.000 EA	4068.00 INR		366.12 @ 9.0 %	366.12 @ 9.0 %	02/13/19	4068.00	
3	ZMRS0069 MACHINING CHARGES OF WELDED DIE 1225 BLK TOP		998331	1.000 EA	3790.80 INR		341.17 @ 9.0 %	341.17 @ 9.0 %	02/13/19	3790.80	
4	ZMRS0069 MACHINING CHARGES OF WELDED DIE 1225 BLK BTM		998331	1.000 EA	6660.00 INR		599.40 @ 9.0 %	599.40 @ 9.0 %	02/13/19	6660.00	
								Total :	21430.80		
								CGST Input@9%	1928.77		
								SGST Input@9%	1928.77		
								Other			
								Suspense Account			
								Suspense Setoff Account			
								Grand Total :	25288.34		
Grand Total (In Words) : RUPEES TWENTY FIVE THOUSAND TWO HUNDRED EIGHTY EIGHT AND PAISE THIRTY FOUR ONLY Delivery Terms : Remarks : Payment Terms : 30 Days From Acceptance											

Checked By

Authorized By

For all queries related to this order contact
www.rsbglobal.com

CORPORATE OFFICE: Ubale Nagar, Nagar Road, Wagoli, Pune, 412207, Tel : 91 20 30642100 Fax : 91 20 30642101

TERMS & CONDITIONS**GENERAL**

1. Written acceptance of this PO or Commencement of supply/service against this PO shall constitute acceptance of this Purchase Order.
2. Delivery Challan/Invoice in duplicate should accompany all supplies made mentioning in there clearly supplier code, drawing no., part no., description of material PO no. specified in Purchase/subcontract & quantity supplied.
3. In the case of excisable goods transporter's copy should be send along with material otherwise bill/invoice will be held up. Failure to comply with this & consequent loss of mod vat credit on account of excise duty will be debited to your account where document are routed through bank send the transporter copy along with consent & enclose copy of invoice with document routed through bank. Attested/certified/Photostat copies of transporter's copy of invoice are not acceptable at all.
4. In case of subcontract item with our material failure to supply or return the material within 90 days under rule 4(5)(a) of central excise the excise duty payable in then will be debited to your account.
5. All drawings samples or technical data supplied to you by us shall be kept as secret & shall not be sold or disclosed & these shall be returned to as & when demanded. Failure to comply with this shall make you liable for breach of trust & other actions as may be deemed fit by us.
6. The items manufactured by you from the date furnished by us must not be sold or divulged by you to any other party than ourselves. If you manufacture excess quantity than our order you shall preserve the same for ultimate sale to us on our demand. Alternatively you destroy the goods so manufactured by you. By no account you will sell goods to any other party except with our written consent. The same condition applies to supplies rejected by us parts similar to parts manufactured for us; should not be manufactured by you.
7. No upward revision of price will be permitted during the period of contract unless agreed by us.
8. Terms & condition stated in our purchase/subcontract will be final until the supplier has our written consent to his terms & conditions if any stated in his order acceptance letter.
9. Any letter sent by prepaid registered post to the address given in this order shall be deemed to have been received by party within 3 days of dispatch thereof; irrespective of fact whether the said letter is or is not in fact received by party so addressed.
10. The company reserves the right to cancel & terminate the contract. If prevented by any intervention or control by government authorities or any other cause beyond the control of the company where by company is unable to make use the materials ordered by stoppage suspension of production or otherwise.
11. Local civil court shall have the jurisdiction to try any dispute concerning all our purchase/subcontract.
12. The material should be properly packed to avoid any kind of damage or formation of rust during transportation or storage.
13. Strict adherence to terms of delivery is absolutely essential. The company reserves the right to treat the order as cancelled in the event of your non-compliance of delivery schedule agreed & material will be brought from open market at your risk & cost. Time of delivery shall be essence of contract.
14. Demurrage, penalties etc. shall be levied on account of delay in delivery, dispatch or railway/lorry receipts, advance of invoice & challans or any other shipping documents or for any other reason for which the company is not responsible will be to the supplier's account & recoverable from him.
15. The material must be dispatched by the mode or transport & to the destination mentioned in this order. In case partial suppliers our prior approval must be obtained.
16. If transport arrangement is made by RSB for collection & dispatch of components it will be totally the supplier's risk RSB is not responsible for any shortages damages in such Arrangement supplier should send their representative with each consignment for collection & delivery to ensure safe transit of material.
17. Supplier shall give advance information to buyer in writing for all specification change design changes as well as major changes in processing location of manufacturing applying to goods covered by this Purchase order.
18. All vehicles used for transportation of material should comply to the central motor & vehicle rules act as applicable from time to time. The transporter is required to carry PUC vehicle fitness certificate of transportation vehicle during delivery.
19. Supplier should inform dispatch details immediately after dispatch.
20. Material supplied by seller shall satisfy current Govt. & environmental (ISO 14001:2015) (OHSAS 18001:2007) constraints on restricted toxic & hazardous materials.
21. Supplier shall ensure coverage of transit insurance for material.
22. Supplier shall protect the third party trade secret or proprietary information for material or copy rights supplied by RSB. Failure to do so will result in PO being cancelled with immediate effect.

PAYMENT

1. Payment will be made as stipulated in this order, if the payment is agreed to be made against document through Bank. All bank charges involved shall be borne by the Supplier. Failure by the Supplier to advice his banker to recover all bank charges from supplier. Will result in non-retirement of documents at his own risk and cost.
2. All payments will be done as per applicable RSB policies.
3. No charges for cartage, packing etc., will admissible unless the same is specifically included in our Purchase/ Sub Contract.

SUPPLIER'S QUALITY ASSURANCE

1. All the materials, Component supplied must critically meet RSB Quality standards required as per samples, drawings, specifications or any other related instructions. The supplier shall allow, RSB's employee and authorized representatives for the purpose of inspecting manufacturing and inspection facilities, inspection of raw materials, WIP, FG, machines tools, fixtures jigs or any other items in connection with the manufacture of components for the company.

SAMPLE APPROVAL

1. No supplies should be made prior to the approval of sample unless specifically asked by us. It shall be the responsibility of the Supplier to submit samples well in time to be able to adhere strictly to the delivery schedule.

REJECTIONS

1. The decisions of the company on rejection shall be final and binding on the Supplier and this time clause shall be deemed to constitute an agreement to the contrary under the Sale of Goods Act. The company shall be entitled to reject the materials at any stage, cancel the contract and buy its requirements in the open market against the supplies. There is no rejection allowed unless specifically mentioned in the P.O. clearly.
2. It will be the liability of the Supplier to remove the rejected material within 15 days from our premises at his cost. In case rejection is not taken back within 15 days RSB is not liable to return back the rejection & no compensation will be given. In case of any rework done the components supplied by the suppliers, rework charges, handling charges, disposal charges & any other related charges as applicable will be recovered from Supplier's bill.
3. Rejection must be replaced within the delivery schedule and will be invoiced separately and not as replacement. All charges inclusive of freight and handling on replacements shall be borne by the Supplier.

WARRANTY

1. All the material supplied, should be free from any manufacturing, process defects & should be as per the drawings, Specifications. Any failure at RSB's customer end due to any deviation on quality, supplier shall be responsible for all damages, claims, recovery directly or indirectly claimed to RSB by any agency. Supplier shall reimburse all such expenses to RSB immediately without any delay on any ground. It will be the responsibility of the supplier to provide free replacement of component & assemblies which fail in the field because of material or manufacturing defects during the Warranty period or during the product life cycle, any offered by the company to its customers.

IN THE CASE OF SUB CONTRACT

1. Material Account to be submitted every month with regards to the Receipts & Supply in the prescribed format.
2. The supplier is responsible for safe custody of Company's material including the RAW Material/ Semi Finished/Finished/Tooling.
3. Periodic Physical Verification will be carried out by company's representative. During which supplier should assist in such verification.
4. The supplier has to obtain in writing the quantum to be consumed for each item supplied to him.
5. Supplier is fully responsible for quantity lifted by him till the entire quantity is supplied by him as per specification.
6. The supplier should also return the resultant scrap generated during machining. The remaining material/semi finished/finished held by supplier shall be property of company & company reserves the right to seek for return of raw material in which event the supplier shall return the same forth with.
7. No process rejection is allowed unless specified in PO specifically. In case process rejection, rejected component should be returned back to RSB on a separate delivery challan. All such components should be marked with red paint & to be supplied in a separate batch to avoid mix up. Process rejection exceeding allowed rejection % full cost of raw material shall be recovered. Line rejection at RSB is not considered in the allowed process rejection (if any). Line rejection will be recovered at full cost & rejected components will not be returned back or no scrap benefit will be passed on to supplier.
8. Supplier should ensure coverage of insurance of RSB property on their premises at their own cost.

Checked By

Authorized By

For all queries related to this order contact
www.rsbglobal.com

CORPORATE OFFICE: Ubale Nagar, Nagar Road, Wagoli, Pune, 412207, Tel : 91 20 30642100 Fax : 91 20 30642101



PURCHASE ORDER

Principal Place of Business/Bill To					Supply To						
RSB Transmissions (I) Ltd. (Forging Plant) Plot no. 1007, 1011 P.O. Uchapada Tel : 91674-2550590 Fax : 91674-2550590 Email : ranjan.jena@rsbglobal.com Website : www.rsbglobal.com GSTIN : 21AABCR3925R1Z5 PAN : AABCR3925R State Code & State : 21 ODISHA CIN : U34102PN1989PLC014807					RSB TRANSMISSIONS (I) LTD.(Cuttack) CUTTACK UNIT -1, NH-5,PLOT NO.1011,1007 MANIA,KOTSAHI,TANGI,CHOUDWAR 754022 Tel : 91674-2550590 Fax : 91674-2550590 Email : ranjan.jena@rsbglobal.com Website : www.rsbglobal.com GSTIN : 21AABCR3925R1Z5 PAN : AABCR3925R State Code & State : 21 ODISHA CIN : U34102PN1989PLC014807						
Supplier Details					PO Details						
Supplier Code : 40007025 Name : GRAMTARANG EMPLOYABILITY TRNG SERV P LTD Address : C/O ? CENTURION UNIVERSITY GRAM TARANG EMPLOYABILITY TRAINING SERVICES, AT- RAMACHANDRAPUR,JATANI , BHUBANESWAR Tel : Email : subratkumar.swain@gramtarang.org.in GSTIN : 21AABCC9406C1ZB PAN : AABCC9406C State Code & State : 21 ODISHA					Order Type/Order No : O2 / 18000397 Order Date : 13/02/2019 Revision No/ Date : 0 / 13/02/2019 Quotation No/ Date : Our Reference No. : Original Order No. : Validity Date : 31/03/2019						
No.	Item Code	Drawing No.	HSN	Quantity	Rate	GST Amount/Percentage			Request Date	Amount (Qty x Rate)	
	Description	Mod No:	SAC	UOM	Currency	IGST	CGST	SGST			
1	ZMRS0069 MACHINING CHARGES OF WELDED DIE 1214 FIN TOP		998331	1.000 EA	5371.20 INR		483.41 @ 9.0 %	483.41 @ 9.0 %	02/13/19	5371.20	
2	ZMRS0069 MACHINING CHARGES OF WELDED DIE 1214 FIN BTM		998331	1.000 EA	7308.00 INR		657.72 @ 9.0 %	657.72 @ 9.0 %	02/13/19	7308.00	
3	ZMRS0069 MACHINING CHARGES OF WELDED DIE 1214 BLK TOP		998331	1.000 EA	5472.00 INR		492.48 @ 9.0 %	492.48 @ 9.0 %	02/13/19	5472.00	
4	ZMRS0069 MACHINING CHARGES OF WELDED DIE 1214 BLK BTM		998331	1.000 EA	7092.00 INR		638.28 @ 9.0 %	638.28 @ 9.0 %	02/13/19	7092.00	
									Total :	25243.20	
									CGST Input@9%	2271.89	
									SGST Input@9%	2271.89	
									Other		
									Suspense Account		
									Suspense Setoff Account		
									Grand Total :	29786.98	
Grand Total (In Words) : RUPEES TWENTY NINE THOUSAND SEVEN HUNDRED EIGHTY SIX AND PAISE NINETY EIGHT ONLY Delivery Terms : Remarks : Payment Terms : 30 Days From Acceptance											

Checked By

Authorized By

For all queries related to this order contact
www.rsbglobal.com

CORPORATE OFFICE: Ubale Nagar, Nagar Road, Wagoli, Pune, 412207, Tel : 91 20 30642100 Fax : 91 20 30642101

TERMS & CONDITIONS**GENERAL**

1. Written acceptance of this PO or Commencement of supply/service against this PO shall constitute acceptance of this Purchase Order.
2. Delivery Challan/Invoice in duplicate should accompany all supplies made mentioning in there clearly supplier code, drawing no., part no., description of material PO no. specified in Purchase/subcontract & quantity supplied.
3. In the case of excisable goods transporter's copy should be send along with material otherwise bill/invoice will be held up. Failure to comply with this & consequent loss of mod vat credit on account of excise duty will be debited to your account where document are routed through bank send the transporter copy along with consent & enclose copy of invoice with document routed through bank. Attested/certified/Photostat copies of transporter's copy of invoice are not acceptable at all.
4. In case of subcontract item with our material failure to supply or return the material within 90 days under rule 4(5)(a) of central excise the excise duty payable in then will be debited to your account.
5. All drawings samples or technical data supplied to you by us shall be kept as secret & shall not be sold or disclosed & these shall be returned to as & when demanded. Failure to comply with this shall make you liable for breach of trust & other actions as may be deemed fit by us.
6. The items manufactured by you from the date furnished by us must not be sold or divulged by you to any other party than ourselves. If you manufacture excess quantity than our order you shall preserve the same for ultimate sale to us on our demand. Alternatively you destroy the goods so manufactured by you. By no account you will sell goods to any other party except with our written consent. The same condition applies to supplies rejected by us parts similar to parts manufactured for us; should not be manufactured by you.
7. No upward revision of price will be permitted during the period of contract unless agreed by us.
8. Terms & condition stated in our purchase/subcontract will be final until the supplier has our written consent to his terms & conditions if any stated in his order acceptance letter.
9. Any letter sent by prepaid registered post to the address given in this order shall be deemed to have been received by party within 3 days of dispatch thereof; irrespective of fact whether the said letter is or is not in fact received by party so addressed.
10. The company reserves the right to cancel & terminate the contract. If prevented by any intervention or control by government authorities or any other cause beyond the control of the company where by company is unable to make use the materials ordered by stoppage suspension of production or otherwise.
11. Local civil court shall have the jurisdiction to try any dispute concerning all our purchase/subcontract.
12. The material should be properly packed to avoid any kind of damage or formation of rust during transportation or storage.
13. Strict adherence to terms of delivery is absolutely essential. The company reserves the right to treat the order as cancelled in the event of your non-compliance of delivery schedule agreed & material will be brought from open market at your risk & cost. Time of delivery shall be essence of contract.
14. Demurrage, penalties etc. shall be levied on account of delay in delivery, dispatch or railway/lorry receipts, advance of invoice & challans or any other shipping documents or for any other reason for which the company is not responsible will be to the supplier's account & recoverable from him.
15. The material must be dispatched by the mode or transport & to the destination mentioned in this order. In case partial suppliers our prior approval must be obtained.
16. If transport arrangement is made by RSB for collection & dispatch of components it will be totally the supplier's risk RSB is not responsible for any shortages damages in such Arrangement supplier should send their representative with each consignment for collection & delivery to ensure safe transit of material.
17. Supplier shall give advance information to buyer in writing for all specification change design changes as well as major changes in processing location of manufacturing applying to goods covered by this Purchase order.
18. All vehicles used for transportation of material should comply to the central motor & vehicle rules act as applicable from time to time. The transporter is required to carry PUC vehicle fitness certificate of transportation vehicle during delivery.
19. Supplier should inform dispatch details immediately after dispatch.
20. Material supplied by seller shall satisfy current Govt. & environmental (ISO 14001:2015) (OHSAS 18001:2007) constraints on restricted toxic & hazardous materials.
21. Supplier shall ensure coverage of transit insurance for material.
22. Supplier shall protect the third party trade secret or proprietary information for material or copy rights supplied by RSB. Failure to do so will result in PO being cancelled with immediate effect.

PAYMENT

1. Payment will be made as stipulated in this order, if the payment is agreed to be made against document through Bank. All bank charges involved shall be borne by the Supplier. Failure by the Supplier to advice his banker to recover all bank charges from supplier. Will result in non-retirement of documents at his own risk and cost.
2. All payments will be done as per applicable RSB policies.
3. No charges for cartage, packing etc., will admissible unless the same is specifically included in our Purchase/ Sub Contract.

SUPPLIER'S QUALITY ASSURANCE

1. All the materials, Component supplied must critically meet RSB Quality standards required as per samples, drawings, specifications or any other related instructions. The supplier shall allow, RSB's employee and authorized representatives for the purpose of inspecting manufacturing and inspection facilities, inspection of raw materials, WIP, FG, machines tools, fixtures jigs or any other items in connection with the manufacture of components for the company.

SAMPLE APPROVAL

1. No supplies should be made prior to the approval of sample unless specifically asked by us. It shall be the responsibility of the Supplier to submit samples well in time to be able to adhere strictly to the delivery schedule.

REJECTIONS

1. The decisions of the company on rejection shall be final and binding on the Supplier and this time clause shall be deemed to constitute an agreement to the contrary under the Sale of Goods Act. The company shall be entitled to reject the materials at any stage, cancel the contract and buy its requirements in the open market against the supplies. There is no rejection allowed unless specifically mentioned in the P.O. clearly.
2. It will be the liability of the Supplier to remove the rejected material within 15 days from our premises at his cost. In case rejection is not taken back within 15 days RSB is not liable to return back the rejection & no compensation will be given. In case of any rework done the components supplied by the suppliers, rework charges, handling charges, disposal charges & any other related charges as applicable will be recovered from Supplier's bill.
3. Rejection must be replaced within the delivery schedule and will be invoiced separately and not as replacement. All charges inclusive of freight and handling on replacements shall be borne by the Supplier.

WARRANTY

1. All the material supplied, should be free from any manufacturing, process defects & should be as per the drawings, Specifications. Any failure at RSB's customer end due to any deviation on quality, supplier shall be responsible for all damages, claims, recovery directly or indirectly claimed to RSB by any agency. Supplier shall reimburse all such expenses to RSB immediately without any delay on any ground. It will be the responsibility of the supplier to provide free replacement of component & assemblies which fail in the field because of material or manufacturing defects during the Warranty period or during the product life cycle, any offered by the company to its customers.

IN THE CASE OF SUB CONTRACT

1. Material Account to be submitted every month with regards to the Receipts & Supply in the prescribed format.
2. The supplier is responsible for safe custody of Company's material including the RAW Material/ Semi Finished/Finished/Tooling.
3. Periodic Physical Verification will be carried out by company's representative. During which supplier should assist in such verification.
4. The supplier has to obtain in writing the quantum to be consumed for each item supplied to him.
5. Supplier is fully responsible for quantity lifted by him till the entire quantity is supplied by him as per specification.
6. The supplier should also return the resultant scrap generated during machining. The remaining material/semi finished/finished held by supplier shall be property of company & company reserves the right to seek for return of raw material in which event the supplier shall return the same forth with.
7. No process rejection is allowed unless specified in PO specifically. In case process rejection, rejected component should be returned back to RSB on a separate delivery challan. All such components should be marked with red paint & to be supplied in a separate batch to avoid mix up. Process rejection exceeding allowed rejection % full cost of raw material shall be recovered. Line rejection at RSB is not considered in the allowed process rejection (if any). Line rejection will be recovered at full cost & rejected components will not be returned back or no scrap benefit will be passed on to supplier.
8. Supplier should ensure coverage of insurance of RSB property on their premises at their own cost.

Checked By

Authorized By

For all queries related to this order contact
www.rsbglobal.com

CORPORATE OFFICE: Ubale Nagar, Nagar Road, Wagoli, Pune, 412207, Tel : 91 20 30642100 Fax : 91 20 30642101



PURCHASE ORDER

Principal Place of Business/Bill To					Supply To						
RSB Transmissions (I) Ltd. (Forging Plant) Plot no. 1007, 1011 P.O. Uchapada Tel : 91674-2550590 Fax : 91674-2550590 Email : ranjan.jena@rsbglobal.com Website : www.rsbglobal.com GSTIN : 21AABCR3925R1Z5 PAN : AABCR3925R State Code & State : 21 ODISHA CIN : U34102PN1989PLC014807					RSB TRANSMISSIONS (I) LTD.(Cuttack) CUTTACK UNIT -1, NH-5,PLOT NO.1011,1007 MANIA,KOTSAHI,TANGI,CHOUDWAR 754022 Tel : 91674-2550590 Fax : 91674-2550590 Email : ranjan.jena@rsbglobal.com Website : www.rsbglobal.com GSTIN : 21AABCR3925R1Z5 PAN : AABCR3925R State Code & State : 21 ODISHA CIN : U34102PN1989PLC014807						
Supplier Details					PO Details						
Supplier Code : 40007025 Name : GRAMTARANG EMPLOYABILITY TRNG SERV P LTD Address : C/O ? CENTURION UNIVERSITY GRAM TARANG EMPLOYABILITY TRAINING SERVICES, AT- RAMACHANDRAPUR,JATANI , BHUBANESWAR Tel : Email : subratkumar.swain@gramtarang.org.in GSTIN : 21AABCC9406C1ZB PAN : AABCC9406C State Code & State : 21 ODISHA					Order Type/Order No : O2 / 18000404 Order Date : 22/02/2019 Revision No/ Date : 0 / 22/02/2019 Quotation No/ Date : Our Reference No. : Original Order No. : Validity Date : 31/03/2019						
No.	Item Code	Drawing No.	HSN	Quantity	Rate	GST Amount/Percentage			Request Date	Amount (Qty x Rate)	
	Description	Mod No:	SAC	UOM	Currency	IGST	CGST	SGST			
1	ZMRS0069 MACHINING CHARGES OF WELDED DIE 1002L BLK BTM		998331	1.000 EA	4824.00 INR		434.16 @ 9.0 %	434.16 @ 9.0 %	02/22/19	4824.00	
2	ZMRS0069 MACHINING CHARGES OF WELDED DIE 1002L BLK TOP		998331	1.000 EA	5158.80 INR		464.29 @ 9.0 %	464.29 @ 9.0 %	02/22/19	5158.80	
3	ZMRS0069 MACHINING CHARGES OF WELDED DIE 1002L FIN TOP		998331	1.000 EA	4752.00 INR		427.68 @ 9.0 %	427.68 @ 9.0 %	02/22/19	4752.00	
4	ZMRS0069 MACHINING CHARGES OF WELDED DIE 1002L FIN BTM		998331	1.000 EA	5220.00 INR		469.80 @ 9.0 %	469.80 @ 9.0 %	02/22/19	5220.00	
								Total :	19954.80		
								CGST Input@9%	1795.93		
								SGST Input@9%	1795.93		
								Other			
								Suspense Account			
								Suspense Setoff Account			
								Grand Total :	23546.66		
Grand Total (In Words) : RUPEES TWENTY THREE THOUSAND FIVE HUNDRED FORTY SIX AND PAISE SIXTY SIX ONLY Delivery Terms : AS PER CAM SHEET. FOR PLANT DELIVERY. Remarks : Payment Terms : 30 Days From Acceptance											

Checked By

Authorized By

For all queries related to this order contact
www.rsbglobal.com

CORPORATE OFFICE: Ubale Nagar, Nagar Road, Wagoli, Pune, 412207, Tel : 91 20 30642100 Fax : 91 20 30642101

TERMS & CONDITIONS**GENERAL**

1. Written acceptance of this PO or Commencement of supply/service against this PO shall constitute acceptance of this Purchase Order.
2. Delivery Challan/Invoice in duplicate should accompany all supplies made mentioning in there clearly supplier code, drawing no., part no., description of material PO no. specified in Purchase/subcontract & quantity supplied.
3. In the case of excisable goods transporter's copy should be send along with material otherwise bill/invoice will be held up. Failure to comply with this & consequent loss of mod vat credit on account of excise duty will be debited to your account where document are routed through bank send the transporter copy along with consent & enclose copy of invoice with document routed through bank. Attested/certified/Photostat copies of transporter's copy of invoice are not acceptable at all.
4. In case of subcontract item with our material failure to supply or return the material within 90 days under rule 4(5)(a) of central excise the excise duty payable in then will be debited to your account.
5. All drawings samples or technical data supplied to you by us shall be kept as secret & shall not be sold or disclosed & these shall be returned to as & when demanded. Failure to comply with this shall make you liable for breach of trust & other actions as may be deemed fit by us.
6. The items manufactured by you from the date furnished by us must not be sold or divulged by you to any other party than ourselves. If you manufacture excess quantity than our order you shall preserve the same for ultimate sale to us on our demand. Alternatively you destroy the goods so manufactured by you. By no account you will sell goods to any other party except with our written consent. The same condition applies to supplies rejected by us parts similar to parts manufactured for us; should not be manufactured by you.
7. No upward revision of price will be permitted during the period of contract unless agreed by us.
8. Terms & condition stated in our purchase/subcontract will be final until the supplier has our written consent to his terms & conditions if any stated in his order acceptance letter.
9. Any letter sent by prepaid registered post to the address given in this order shall be deemed to have been received by party within 3 days of dispatch thereof; irrespective of fact whether the said letter is or is not in fact received by party so addressed.
10. The company reserves the right to cancel & terminate the contract. If prevented by any intervention or control by government authorities or any other cause beyond the control of the company where by company is unable to make use the materials ordered by stoppage suspension of production or otherwise.
11. Local civil court shall have the jurisdiction to try any dispute concerning all our purchase/subcontract.
12. The material should be properly packed to avoid any kind of damage or formation of rust during transportation or storage.
13. Strict adherence to terms of delivery is absolutely essential. The company reserves the right to treat the order as cancelled in the event of your non-compliance of delivery schedule agreed & material will be brought from open market at your risk & cost. Time of delivery shall be essence of contract.
14. Demurrage, penalties etc. shall be levied on account of delay in delivery, dispatch or railway/lorry receipts, advance of invoice & challans or any other shipping documents or for any other reason for which the company is not responsible will be to the supplier's account & recoverable from him.
15. The material must be dispatched by the mode or transport & to the destination mentioned in this order. In case partial suppliers our prior approval must be obtained.
16. If transport arrangement is made by RSB for collection & dispatch of components it will be totally the supplier's risk RSB is not responsible for any shortages damages in such Arrangement supplier should send their representative with each consignment for collection & delivery to ensure safe transit of material.
17. Supplier shall give advance information to buyer in writing for all specification change design changes as well as major changes in processing location of manufacturing applying to goods covered by this Purchase order.
18. All vehicles used for transportation of material should comply to the central motor & vehicle rules act as applicable from time to time. The transporter is required to carry PUC vehicle fitness certificate of transportation vehicle during delivery.
19. Supplier should inform dispatch details immediately after dispatch.
20. Material supplied by seller shall satisfy current Govt. & environmental (ISO 14001:2015) (OHSAS 18001:2007) constraints on restricted toxic & hazardous materials.
21. Supplier shall ensure coverage of transit insurance for material.
22. Supplier shall protect the third party trade secret or proprietary information for material or copy rights supplied by RSB. Failure to do so will result in PO being cancelled with immediate effect.

PAYMENT

1. Payment will be made as stipulated in this order, if the payment is agreed to be made against document through Bank. All bank charges involved shall be borne by the Supplier. Failure by the Supplier to advice his banker to recover all bank charges from supplier. Will result in non-retirement of documents at his own risk and cost.
2. All payments will be done as per applicable RSB policies.
3. No charges for cartage, packing etc., will admissible unless the same is specifically included in our Purchase/ Sub Contract.

SUPPLIER'S QUALITY ASSURANCE

1. All the materials, Component supplied must critically meet RSB Quality standards required as per samples, drawings, specifications or any other related instructions. The supplier shall allow, RSB's employee and authorized representatives for the purpose of inspecting manufacturing and inspection facilities, inspection of raw materials, WIP, FG, machines tools, fixtures jigs or any other items in connection with the manufacture of components for the company.

SAMPLE APPROVAL

1. No supplies should be made prior to the approval of sample unless specifically asked by us. It shall be the responsibility of the Supplier to submit samples well in time to be able to adhere strictly to the delivery schedule.

REJECTIONS

1. The decisions of the company on rejection shall be final and binding on the Supplier and this time clause shall be deemed to constitute an agreement to the contrary under the Sale of Goods Act. The company shall be entitled to reject the materials at any stage, cancel the contract and buy its requirements in the open market against the supplies. There is no rejection allowed unless specifically mentioned in the P.O. clearly.
2. It will be the liability of the Supplier to remove the rejected material within 15 days from our premises at his cost. In case rejection is not taken back within 15 days RSB is not liable to return back the rejection & no compensation will be given. In case of any rework done the components supplied by the suppliers, rework charges, handling charges, disposal charges & any other related charges as applicable will be recovered from Supplier's bill.
3. Rejection must be replaced within the delivery schedule and will be invoiced separately and not as replacement. All charges inclusive of freight and handling on replacements shall be borne by the Supplier.

WARRANTY

1. All the material supplied, should be free from any manufacturing, process defects & should be as per the drawings, Specifications. Any failure at RSB's customer end due to any deviation on quality, supplier shall be responsible for all damages, claims, recovery directly or indirectly claimed to RSB by any agency. Supplier shall reimburse all such expenses to RSB immediately without any delay on any ground. It will be the responsibility of the supplier to provide free replacement of component & assemblies which fail in the field because of material or manufacturing defects during the Warranty period or during the product life cycle, any offered by the company to its customers.

IN THE CASE OF SUB CONTRACT

1. Material Account to be submitted every month with regards to the Receipts & Supply in the prescribed format.
2. The supplier is responsible for safe custody of Company's material including the RAW Material/ Semi Finished/Finished/Tooling.
3. Periodic Physical Verification will be carried out by company's representative. During which supplier should assist in such verification.
4. The supplier has to obtain in writing the quantum to be consumed for each item supplied to him.
5. Supplier is fully responsible for quantity lifted by him till the entire quantity is supplied by him as per specification.
6. The supplier should also return the resultant scrap generated during machining. The remaining material/semi finished/finished held by supplier shall be property of company & company reserves the right to seek for return of raw material in which event the supplier shall return the same forth with.
7. No process rejection is allowed unless specified in PO specifically. In case process rejection, rejected component should be returned back to RSB on a separate delivery challan. All such components should be marked with red paint & to be supplied in a separate batch to avoid mix up. Process rejection exceeding allowed rejection % full cost of raw material shall be recovered. Line rejection at RSB is not considered in the allowed process rejection (if any). Line rejection will be recovered at full cost & rejected components will not be returned back or no scrap benefit will be passed on to supplier.
8. Supplier should ensure coverage of insurance of RSB property on their premises at their own cost.

Checked By

Authorized By

For all queries related to this order contact
www.rsbglobal.com

CORPORATE OFFICE: Ubale Nagar, Nagar Road, Wagoli, Pune, 412207, Tel : 91 20 30642100 Fax : 91 20 30642101



PURCHASE ORDER

Principal Place of Business/Bill To					Supply To						
RSB Transmissions (I) Ltd. (Forging Plant) Plot no. 1007, 1011 P.O. Uchapada Tel : 91674-2550590 Fax : 91674-2550590 Email : ranjan.jena@rsbglobal.com Website : www.rsbglobal.com GSTIN : 21AABCR3925R1Z5 PAN : AABCR3925R State Code & State : 21 ODISHA CIN : U34102PN1989PLC014807					RSB TRANSMISSIONS (I) LTD.(Cuttack) CUTTACK UNIT -1, NH-5,PLOT NO.1011,1007 MANIA,KOTSAHI,TANGI,CHOUDWAR 754022 Tel : 91674-2550590 Fax : 91674-2550590 Email : ranjan.jena@rsbglobal.com Website : www.rsbglobal.com GSTIN : 21AABCR3925R1Z5 PAN : AABCR3925R State Code & State : 21 ODISHA CIN : U34102PN1989PLC014807						
Supplier Details					PO Details						
Supplier Code : 40007025 Name : GRAMTARANG EMPLOYABILITY TRNG SERV P LTD Address : C/O ? CENTURION UNIVERSITY GRAM TARANG EMPLOYABILITY TRAINING SERVICES, AT- RAMACHANDRAPUR,JATANI , BHUBANESWAR Tel : Email : subratkumar.swain@gramtarang.org.in GSTIN : 21AABCC9406C1ZB PAN : AABCC9406C State Code & State : 21 ODISHA					Order Type/Order No : O2 / 18000405 Order Date : 22/02/2019 Revision No/ Date : 0 / 22/02/2019 Quotation No/ Date : Our Reference No. : Original Order No. : Validity Date : 31/03/2019						
No.	Item Code	Drawing No.	HSN	Quantity	Rate	GST Amount/Percentage			Request Date	Amount (Qty x Rate)	
	Description	Mod No:	SAC	UOM	Currency	IGST	CGST	SGST			
1	ZMRS0069 MACHINING CHARGES OF WELDED DIE 1026 BLK BTM		998331	1.000 EA	4554.00 INR		409.86 @ 9.0 %	409.86 @ 9.0 %	02/22/19	4554.00	
2	ZMRS0069 MACHINING CHARGES OF WELDED DIE 1026 FIN TOP		998331	1.000 EA	4546.80 INR		409.21 @ 9.0 %	409.21 @ 9.0 %	02/22/19	4546.80	
							Total :			9100.80	
							CGST Input@9%				819.07
							SGST Input@9%				819.07
							Other				
							Suspense Account				
							Suspense Setoff Account				
							Grand Total :				10738.94
Grand Total (In Words) : RUPEES TEN THOUSAND SEVEN HUNDRED THIRTY EIGHT AND PAISE NINETY FOUR ONLY Delivery Terms : AS PER CAMSHEET. FOR PLANT DELIVERY. Remarks : Payment Terms : 30 Days From Acceptance											

Checked By

Authorized By

For all queries related to this order contact
www.rsbglobal.com

CORPORATE OFFICE: Ubale Nagar, Nagar Road, Wagoli, Pune, 412207, Tel : 91 20 30642100 Fax : 91 20 30642101

TERMS & CONDITIONS**GENERAL**

1. Written acceptance of this PO or Commencement of supply/service against this PO shall constitute acceptance of this Purchase Order.
2. Delivery Challan/Invoice in duplicate should accompany all supplies made mentioning in there clearly supplier code, drawing no., part no., description of material PO no. specified in Purchase/subcontract & quantity supplied.
3. In the case of excisable goods transporter's copy should be send along with material otherwise bill/invoice will be held up. Failure to comply with this & consequent loss of mod vat credit on account of excise duty will be debited to your account where document are routed through bank send the transporter copy along with consent & enclose copy of invoice with document routed through bank. Attested/certified/Photostat copies of transporter's copy of invoice are not acceptable at all.
4. In case of subcontract item with our material failure to supply or return the material within 90 days under rule 4(5)(a) of central excise the excise duty payable in then will be debited to your account.
5. All drawings samples or technical data supplied to you by us shall be kept as secret & shall not be sold or disclosed & these shall be returned to as & when demanded. Failure to comply with this shall make you liable for breach of trust & other actions as may be deemed fit by us.
6. The items manufactured by you from the date furnished by us must not be sold or divulged by you to any other party than ourselves. If you manufacture excess quantity than our order you shall preserve the same for ultimate sale to us on our demand. Alternatively you destroy the goods so manufactured by you. By no account you will sell goods to any other party except with our written consent. The same condition applies to supplies rejected by us parts similar to parts manufactured for us; should not be manufactured by you.
7. No upward revision of price will be permitted during the period of contract unless agreed by us.
8. Terms & condition stated in our purchase/subcontract will be final until the supplier has our written consent to his terms & conditions if any stated in his order acceptance letter.
9. Any letter sent by prepaid registered post to the address given in this order shall be deemed to have been received by party within 3 days of dispatch thereof; irrespective of fact whether the said letter is or is not in fact received by party so addressed.
10. The company reserves the right to cancel & terminate the contract. If prevented by any intervention or control by government authorities or any other cause beyond the control of the company where by company is unable to make use the materials ordered by stoppage suspension of production or otherwise.
11. Local civil court shall have the jurisdiction to try any dispute concerning all our purchase/subcontract.
12. The material should be properly packed to avoid any kind of damage or formation of rust during transportation or storage.
13. Strict adherence to terms of delivery is absolutely essential. The company reserves the right to treat the order as cancelled in the event of your non-compliance of delivery schedule agreed & material will be brought from open market at your risk & cost. Time of delivery shall be essence of contract.
14. Demurrage, penalties etc. shall be levied on account of delay in delivery, dispatch or railway/lorry receipts, advance of invoice & challans or any other shipping documents or for any other reason for which the company is not responsible will be to the supplier's account & recoverable from him.
15. The material must be dispatched by the mode or transport & to the destination mentioned in this order. In case partial suppliers our prior approval must be obtained.
16. If transport arrangement is made by RSB for collection & dispatch of components it will be totally the supplier's risk RSB is not responsible for any shortages damages in such Arrangement supplier should send their representative with each consignment for collection & delivery to ensure safe transit of material.
17. Supplier shall give advance information to buyer in writing for all specification change design changes as well as major changes in processing location of manufacturing applying to goods covered by this Purchase order.
18. All vehicles used for transportation of material should comply to the central motor & vehicle rules act as applicable from time to time. The transporter is required to carry PUC vehicle fitness certificate of transportation vehicle during delivery.
19. Supplier should inform dispatch details immediately after dispatch.
20. Material supplied by seller shall satisfy current Govt. & environmental (ISO 14001:2015) (OHSAS 18001:2007) constraints on restricted toxic & hazardous materials.
21. Supplier shall ensure coverage of transit insurance for material.
22. Supplier shall protect the third party trade secret or proprietary information for material or copy rights supplied by RSB. Failure to do so will result in PO being cancelled with immediate effect.

PAYMENT

1. Payment will be made as stipulated in this order, if the payment is agreed to be made against document through Bank. All bank charges involved shall be borne by the Supplier. Failure by the Supplier to advice his banker to recover all bank charges from supplier. Will result in non-retirement of documents at his own risk and cost.
2. All payments will be done as per applicable RSB policies.
3. No charges for cartage, packing etc., will admissible unless the same is specifically included in our Purchase/ Sub Contract.

SUPPLIER'S QUALITY ASSURANCE

1. All the materials, Component supplied must critically meet RSB Quality standards required as per samples, drawings, specifications or any other related instructions. The supplier shall allow, RSB's employee and authorized representatives for the purpose of inspecting manufacturing and inspection facilities, inspection of raw materials, WIP, FG, machines tools, fixtures jigs or any other items in connection with the manufacture of components for the company.

SAMPLE APPROVAL

1. No supplies should be made prior to the approval of sample unless specifically asked by us. It shall be the responsibility of the Supplier to submit samples well in time to be able to adhere strictly to the delivery schedule.

REJECTIONS

1. The decisions of the company on rejection shall be final and binding on the Supplier and this time clause shall be deemed to constitute an agreement to the contrary under the Sale of Goods Act. The company shall be entitled to reject the materials at any stage, cancel the contract and buy its requirements in the open market against the supplies. There is no rejection allowed unless specifically mentioned in the P.O. clearly.
2. It will be the liability of the Supplier to remove the rejected material within 15 days from our premises at his cost. In case rejection is not taken back within 15 days RSB is not liable to return back the rejection & no compensation will be given. In case of any rework done the components supplied by the suppliers, rework charges, handling charges, disposal charges & any other related charges as applicable will be recovered from Supplier's bill.
3. Rejection must be replaced within the delivery schedule and will be invoiced separately and not as replacement. All charges inclusive of freight and handling on replacements shall be borne by the Supplier.

WARRANTY

1. All the material supplied, should be free from any manufacturing, process defects & should be as per the drawings, Specifications. Any failure at RSB's customer end due to any deviation on quality, supplier shall be responsible for all damages, claims, recovery directly or indirectly claimed to RSB by any agency. Supplier shall reimburse all such expenses to RSB immediately without any delay on any ground. It will be the responsibility of the supplier to provide free replacement of component & assemblies which fail in the field because of material or manufacturing defects during the Warranty period or during the product life cycle, any offered by the company to its customers.

IN THE CASE OF SUB CONTRACT

1. Material Account to be submitted every month with regards to the Receipts & Supply in the prescribed format.
2. The supplier is responsible for safe custody of Company's material including the RAW Material/ Semi Finished/Finished/Tooling.
3. Periodic Physical Verification will be carried out by company's representative. During which supplier should assist in such verification.
4. The supplier has to obtain in writing the quantum to be consumed for each item supplied to him.
5. Supplier is fully responsible for quantity lifted by him till the entire quantity is supplied by him as per specification.
6. The supplier should also return the resultant scrap generated during machining. The remaining material/semi finished/finished held by supplier shall be property of company & company reserves the right to seek for return of raw material in which event the supplier shall return the same forth with.
7. No process rejection is allowed unless specified in PO specifically. In case process rejection, rejected component should be returned back to RSB on a separate delivery challan. All such components should be marked with red paint & to be supplied in a separate batch to avoid mix up. Process rejection exceeding allowed rejection % full cost of raw material shall be recovered. Line rejection at RSB is not considered in the allowed process rejection (if any). Line rejection will be recovered at full cost & rejected components will not be returned back or no scrap benefit will be passed on to supplier.
8. Supplier should ensure coverage of insurance of RSB property on their premises at their own cost.

Checked By

Authorized By

For all queries related to this order contact
www.rsbglobal.com

CORPORATE OFFICE: Ubale Nagar, Nagar Road, Wagoli, Pune, 412207, Tel : 91 20 30642100 Fax : 91 20 30642101



PURCHASE ORDER

Principal Place of Business/Bill To					Supply To					
RSB Transmissions (I) Ltd. (Forging Plant) Plot no. 1007, 1011 P.O. Uchapada Tel : 91674-2550590 Fax : 91674-2550590 Email : ranjan.jena@rsbglobal.com Website : www.rsbglobal.com GSTIN : 21AABCR3925R1Z5 PAN : AABCR3925R State Code & State : 21 ODISHA CIN : U34102PN1989PLC014807					RSB TRANSMISSIONS (I) LTD.(Cuttack) CUTTACK UNIT -1, NH-5,PLOT NO.1011,1007 MANIA,KOTSAHI,TANGI,CHOUDWAR 754022 Tel : 91674-2550590 Fax : 91674-2550590 Email : ranjan.jena@rsbglobal.com Website : www.rsbglobal.com GSTIN : 21AABCR3925R1Z5 PAN : AABCR3925R State Code & State : 21 ODISHA CIN : U34102PN1989PLC014807					
Supplier Details					PO Details					
Supplier Code : 40007025 Name : GRAMTARANG EMPLOYABILITY TRNG SERV P LTD Address : C/O ? CENTURION UNIVERSITY GRAM TARANG EMPLOYABILITY TRAINING SERVICES, AT- RAMACHANDRAPUR,JATANI , BHUBANESWAR Tel : Email : subratkumar.swain@gramtarang.org.in GSTIN : 21AABCC9406C1ZB PAN : AABCC9406C State Code & State : 21 ODISHA					Order Type/Order No : OS / 18000024 Order Date : 07/23/18 Revision No/ Date : 0 / 07/23/18 Quotation No/ Date : Our Reference No. : AS PER CAM SHEET Original Order No. : Validity Date : 12/31/18					
No.	Item Code	Drawing No.	HSN	Quantity	Rate	GST Amount/Percentage			Request Date	Amount (Qty x Rate)
	Description	Mod No:	SAC	UOM	Currency	IGST	CGST	SGST		
1	PTRPD1808*P10 TRIMMER PUNCH D1808		82073000	1.000 EA	3708.00 INR		333.72 @ 9.0 %	333.72 @ 9.0 %	07/23/18	3708.00
2	PTRPLD1808*OP10 TRIM PUNCH PLATE D1808		82073000	1.000 EA	720.00 INR		64.80 @ 9.0 %	64.80 @ 9.0 %	07/23/18	720.00
									Total :	4428.00
									CGST Input@9%	398.52
									SGST Input@9%	398.52
									Other	
									Suspense Account	
									Suspense Setoff Account	
									Grand Total :	5225.04
Grand Total (In Words) : Rupees Five Thousand Two Hundred Twenty Five and paise Four Only. Delivery Terms : EX-WORKS. Remarks : Payment Terms : 30 Days From Acceptance										

Checked By

Authorized By

For all queries related to this order contact
www.rsbglobal.com

CORPORATE OFFICE: Ubale Nagar, Nagar Road, Wagoli, Pune, 412207, Tel : 91 20 30642100 Fax : 91 20 30642101

TERMS & CONDITIONS**GENERAL**

1. Written acceptance of this PO or Commencement of supply/service against this PO shall constitute acceptance of this Purchase Order.
2. Delivery Challan/Invoice in duplicate should accompany all supplies made mentioning in there clearly supplier code, drawing no., part no., description of material PO no. specified in Purchase/subcontract & quantity supplied.
3. In the case of excisable goods transporter's copy should be send along with material otherwise bill/invoice will be held up. Failure to comply with this & consequent loss of mod vat credit on account of excise duty will be debited to your account where document are routed through bank send the transporter copy along with consent & enclose copy of invoice with document routed through bank. Attested/certified/Photostat copies of transporter's copy of invoice are not acceptable at all.
4. In case of subcontract item with our material failure to supply or return the material within 90 days under rule 4(5)(a) of central excise the excise duty payable in then will be debited to your account.
5. All drawings samples or technical data supplied to you by us shall be kept as secret & shall not be sold or disclosed & these shall be returned to as & when demanded. Failure to comply with this shall make you liable for breach of trust & other actions as may be deemed fit by us.
6. The items manufactured by you from the date furnished by us must not be sold or divulged by you to any other party than ourselves. If you manufacture excess quantity than our order you shall preserve the same for ultimate sale to us on our demand. Alternatively you destroy the goods so manufactured by you. By no account you will sell goods to any other party except with our written consent. The same condition applies to supplies rejected by us parts similar to parts manufactured for us; should not be manufactured by you.
7. No upward revision of price will be permitted during the period of contract unless agreed by us.
8. Terms & condition stated in our purchase/subcontract will be final until the supplier has our written consent to his terms & conditions if any stated in his order acceptance letter.
9. Any letter sent by prepaid registered post to the address given in this order shall be deemed to have been received by party within 3 days of dispatch thereof; irrespective of fact whether the said letter is or is not in fact received by party so addressed.
10. The company reserves the right to cancel & terminate the contract. If prevented by any intervention or control by government authorities or any other cause beyond the control of the company where by company is unable to make use the materials ordered by stoppage suspension of production or otherwise.
11. Local civil court shall have the jurisdiction to try any dispute concerning all our purchase/subcontract.
12. The material should be properly packed to avoid any kind of damage or formation of rust during transportation or storage.
13. Strict adherence to terms of delivery is absolutely essential. The company reserves the right to treat the order as cancelled in the event of your non-compliance of delivery schedule agreed & material will be brought from open market at your risk & cost. Time of delivery shall be essence of contract.
14. Demurrage, penalties etc. shall be levied on account of delay in delivery, dispatch or railway/lorry receipts, advance of invoice & challans or any other shipping documents or for any other reason for which the company is not responsible will be to the supplier's account & recoverable from him.
15. The material must be dispatched by the mode or transport & to the destination mentioned in this order. In case partial suppliers our prior approval must be obtained.
16. If transport arrangement is made by RSB for collection & dispatch of components it will be totally the supplier's risk RSB is not responsible for any shortages damages in such Arrangement supplier should send their representative with each consignment for collection & delivery to ensure safe transit of material.
17. Supplier shall give advance information to buyer in writing for all specification change design changes as well as major changes in processing location of manufacturing applying to goods covered by this Purchase order.
18. All vehicles used for transportation of material should comply to the central motor & vehicle rules act as applicable from time to time. The transporter is required to carry PUC vehicle fitness certificate of transportation vehicle during delivery.
19. Supplier should inform dispatch details immediately after dispatch.
20. Material supplied by seller shall satisfy current Govt. & environmental (ISO 14001-2004) & safety (OHSAS-18001-2007) constraints on restricted toxic & hazardous materials.
21. Supplier shall ensure coverage of transit insurance for material.
22. Supplier shall protect the third party trade secret or proprietary information for material or copy rights supplied by RSB. Failure to do so will result in PO being cancelled with immediate effect.

PAYMENT

1. Payment will be made as stipulated in this order, if the payment is agreed to be made against document through Bank. All bank charges involved shall be borne by the Supplier. Failure by the Supplier to advice his banker to recover all bank charges from supplier. Will result is non-retirement of documents at his own risk and cost.
2. All payments will be done as per applicable RSB policies.
3. No charges for cartage, packing etc., will admissible unless the same is specifically included in our Purchase/ Sub Contract.

SUPPLIER'S QUALITY ASSURANCE

1. All the materials, Component supplied must critically meet RSB Quality standards required as per samples, drawings, specifications or any other related instructions. The supplier shall allow, RSB's employee and authorized representatives for the purpose of inspecting manufacturing and inspection facilities, inspection of raw materials, WIP, FG, machines tools, fixtures jigs or any other items in connection with the manufacture of components for the company.

SAMPLE APPROVAL

1. No supplies should be made prior to the approval of sample unless specifically asked by us. It shall be the responsibility of the Supplier to submit samples well in time to be able to adhere strictly to the delivery schedule.

REJECTIONS

1. The decisions of the company on rejection shall be final and binding on the Supplier and this time clause shall be deemed to constitute an agreement to the contrary under the Sale of Goods Act. The company shall be entitled to reject the materials at any stage, cancel the contract and buy its requirements in the open market against the supplies. There is no rejection allowed unless specifically mentioned in the P.O. clearly.
2. It will be the liability of the Supplier to remove the rejected material within 15 days from our premises at his cost. In case rejection is not taken back within 15 days RSB is not liable to return back the rejection & no compensation will be given. In case of any rework done the components supplied by the suppliers, rework charges, handling charges, disposal charges & any other related charges as applicable will be recovered from Supplier's bill.
3. Rejection must be replaced within the delivery schedule and will be invoiced separately and not as replacement. All charges inclusive of freight and handling on replacements shall be borne by the Supplier.

WARRANTY

1. All the material supplied, should be free from any manufacturing, process defects & should be as per the drawings, Specifications. Any failure at RSB's customer end due to any deviation on quality, supplier shall be responsible for all damages, claims, recovery directly or indirectly claimed to RSB by any agency. Supplier shall reimburse all such expenses to RSB immediately without any delay on any ground. It will be the responsibility of the supplier to provide free replacement of component & assemblies which fail in the field because of material or manufacturing defects during the Warranty period or during the product life cycle, any offered by the company to its customers.

IN THE CASE OF SUB CONTRACT

1. Material Account to be submitted every month with regards to the Receipts & Supply in the prescribed format.
2. The supplier is responsible for safe custody of Company's material including the RAW Material/ Semi Finished/Finished/Tooling.
3. Periodic Physical Verification will be carried out by company's representative. During which supplier should assist in such verification.
4. The supplier has to obtain in writing the quantum to be consumed for each item supplied to him.
5. Supplier is fully responsible for quantity lifted by him till the entire quantity is supplied by him as per specification.
6. The supplier should also return the resultant scrap generated during machining. The remaining material/semi finished/finished held by supplier shall be property of company & company reserves the right to seek for return of raw material in which event the supplier shall return the same forth with.
7. No process rejection is allowed unless specified in PO specifically. In case process rejection, rejected component should be returned back to RSB on a separate delivery challan. All such components should be marked with red paint & to be supplied in a separate batch to avoid mix up. Process rejection exceeding allowed rejection % full cost of raw material shall be recovered. Line rejection at RSB is not considered in the allowed process rejection (if any). Line rejection will be recovered at full cost & rejected components will not be returned back or no scrap benefit will be passed on to supplier.
8. Supplier should ensure coverage of insurance of RSB property on their premises at their own cost.

Checked By

Authorized By

For all queries related to this order contact
www.rsbglobal.com

CORPORATE OFFICE: Ubale Nagar, Nagar Road, Wagoli, Pune, 412207, Tel : 91 20 30642100 Fax : 91 20 30642101



PURCHASE ORDER

Principal Place of Business/Bill To	Supply To
RSB Transmissions (I) Ltd. (Forging Plant) Plot no. 1007, 1011 P.O. Uchapada Tel : 91674-2550590 Fax : 91674-2550590 Email : ranjan.jena@rsbglobal.com Website : www.rsbglobal.com GSTIN : 21AABCR3925R1Z5 PAN : AABCR3925R State Code & State : 21 ODISHA CIN : U34102PN1989PLC014807	RSB TRANSMISSIONS (I) LTD.(Cuttack) CUTTACK UNIT -1, NH-5,PLOT NO.1011,1007 MANIA,KOTSAHI,TANGI,CHOUDWAR 754022 Tel : 91674-2550590 Fax : 91674-2550590 Email : ranjan.jena@rsbglobal.com Website : www.rsbglobal.com GSTIN : 21AABCR3925R1Z5 PAN : AABCR3925R State Code & State : 21 ODISHA CIN : U34102PN1989PLC014807

Supplier Details	PO Details
Supplier Code : 40007025 Name : GRAMTARANG EMPLOYABILITY TRNG SERV P LTD Address : C/O ? CENTURION UNIVERSITY GRAM TARANG EMPLOYABILITY TRAINING SERVICES, AT- RAMACHANDRAPUR,JATANI , BHUBANESWAR Tel : Email : subratkumar.swain@gramtarang.org.in GSTIN : 21AABCC9406C1ZB PAN : AABCC9406C State Code & State : 21 ODISHA	Order Type/Order No : OS / 18000029 Order Date : 07/26/18 Revision No/ Date : 0 / 07/31/18 Quotation No/ Date : Our Reference No. : AS PER CAM SHEET Original Order No. : Validity Date : 01/31/19

No.	Item Code	Drawing No.	HSN	Quantity	Rate	GST Amount/Percentage			Request Date	Amount (Qty x Rate)
	Description	Mod No:	SAC	UOM	Currency	IGST	CGST	SGST		
1	PTRD1809*OP10 TRIMMER DIE D1809		82073000	1.000 EA	5097.60 INR		458.78 @ 9.0 %	458.78 @ 9.0 %	07/26/18	5097.60
2	PTRD1810*OP10 TRIMMER DIE D1810		82073000	1.000 EA	6224.40 INR		560.20 @ 9.0 %	560.20 @ 9.0 %	07/26/18	6224.40
3	PTRPD1810*P10 TRIMMER PUNCH D1810		82073000	1.000 EA	720.00 INR		64.80 @ 9.0 %	64.80 @ 9.0 %	07/26/18	720.00
4	PTRPLD1810*OP10 TRIM PUNCH PLATE D1810		82073000	1.000 EA	3600.00 INR		324.00 @ 9.0 %	324.00 @ 9.0 %	07/26/18	3600.00
5	PTRPLD1809*OP10 TRIM PUNCH PLATE D1809		82073000	1.000 EA	720.00 INR		64.80 @ 9.0 %	64.80 @ 9.0 %	07/26/18	720.00
6	PTRD1811*OP10 TRIMMER DIE D1811		82073000	1.000 EA	5238.00 INR		471.42 @ 9.0 %	471.42 @ 9.0 %	07/26/18	5238.00
7	PTRPD1812*P10 TRIMMER PUNCH D1812		82073000	1.000 EA	2620.80 INR		235.87 @ 9.0 %	235.87 @ 9.0 %	07/26/18	2620.80

Checked By

Authorized By

For all queries related to this order contact
www.rsbglobal.com

CORPORATE OFFICE: Ubale Nagar, Nagar Road, Wagoli, Pune, 412207, Tel : 91 20 30642100 Fax : 91 20 30642101



PURCHASE ORDER

8	PTRD1812*OP10 TRIMMER DIE D1812		82073000	1.000 EA	4305.60 INR		387.50 @ 9.0 %	387.50 @ 9.0 %	07/26/18	4305.60
9	PTRPLD1812*OP10 TRIM PUNCH PLATE D1812		82073000	1.000 EA	720.00 INR		64.80 @ 9.0 %	64.80 @ 9.0 %	07/26/18	720.00
10	PTRPD1809*P10 TRIMMER PUNCH D1809		82073000	1.000 EA	2998.80 INR		269.89 @ 9.0 %	269.89 @ 9.0 %	07/26/18	2998.80
11	PTRPLD1811*OP10 TRIM PUNCH PLATE D1811		82073000	1.000 EA	720.00 INR		64.80 @ 9.0 %	64.80 @ 9.0 %	07/26/18	720.00
12	PTRPD1811*P10 TRIMMER PUNCH D1811		82073000	1.000 EA	3304.80 INR		297.43 @ 9.0 %	297.43 @ 9.0 %	07/26/18	3304.80

									Total :	36270.00
									CGST Input@9%	3264.30
									SGST Input@9%	3264.30
									Other	
									Suspense Account	
									Suspense Setoff Account	
									Grand Total :	42798.60

Grand Total (In Words) : Rupees Forty Two Thousand Seven Hundred Ninety Eight and paise Sixty Only.
 Delivery Terms : EX-WORKS.
 Remarks :
 Payment Terms : 30 Days From Acceptance

Checked By

Authorized By

For all queries related to this order contact
www.rsbglobal.com

CORPORATE OFFICE: Ubale Nagar, Nagar Road, Wagoli, Pune, 412207, Tel : 91 20 30642100 Fax : 91 20 30642101

TERMS & CONDITIONS**GENERAL**

1. Written acceptance of this PO or Commencement of supply/service against this PO shall constitute acceptance of this Purchase Order.
2. Delivery Challan/Invoice in duplicate should accompany all supplies made mentioning in there clearly supplier code, drawing no., part no., description of material PO no. specified in Purchase/subcontract & quantity supplied.
3. In the case of excisable goods transporter's copy should be send along with material otherwise bill/invoice will be held up. Failure to comply with this & consequent loss of mod vat credit on account of excise duty will be debited to your account where document are routed through bank send the transporter copy along with consent & enclose copy of invoice with document routed through bank. Attested/certified/Photostat copies of transporter's copy of invoice are not acceptable at all.
4. In case of subcontract item with our material failure to supply or return the material within 90 days under rule 4(5)(a) of central excise the excise duty payable in then will be debited to your account.
5. All drawings samples or technical data supplied to you by us shall be kept as secret & shall not be sold or disclosed & these shall be returned to as & when demanded. Failure to comply with this shall make you liable for breach of trust & other actions as may be deemed fit by us.
6. The items manufactured by you from the date furnished by us must not be sold or divulged by you to any other party than ourselves. If you manufacture excess quantity than our order you shall preserve the same for ultimate sale to us on our demand. Alternatively you destroy the goods so manufactured by you. By no account you will sell goods to any other party except with our written consent. The same condition applies to supplies rejected by us parts similar to parts manufactured for us; should not be manufactured by you.
7. No upward revision of price will be permitted during the period of contract unless agreed by us.
8. Terms & condition stated in our purchase/subcontract will be final until the supplier has our written consent to his terms & conditions if any stated in his order acceptance letter.
9. Any letter sent by prepaid registered post to the address given in this order shall be deemed to have been received by party within 3 days of dispatch thereof; irrespective of fact whether the said letter is or is not in fact received by party so addressed.
10. The company reserves the right to cancel & terminate the contract. If prevented by any intervention or control by government authorities or any other cause beyond the control of the company where by company is unable to make use the materials ordered by stoppage suspension of production or otherwise.
11. Local civil court shall have the jurisdiction to try any dispute concerning all our purchase/subcontract.
12. The material should be properly packed to avoid any kind of damage or formation of rust during transportation or storage.
13. Strict adherence to terms of delivery is absolutely essential. The company reserves the right to treat the order as cancelled in the event of your non-compliance of delivery schedule agreed & material will be brought from open market at your risk & cost. Time of delivery shall be essence of contract.
14. Demurrage, penalties etc. shall be levied on account of delay in delivery, dispatch or railway/lorry receipts, advance of invoice & challans or any other shipping documents or for any other reason for which the company is not responsible will be to the supplier's account & recoverable from him.
15. The material must be dispatched by the mode or transport & to the destination mentioned in this order. In case partial suppliers our prior approval must be obtained.
16. If transport arrangement is made by RSB for collection & dispatch of components it will be totally the supplier's risk RSB is not responsible for any shortages damages in such Arrangement supplier should send their representative with each consignment for collection & delivery to ensure safe transit of material.
17. Supplier shall give advance information to buyer in writing for all specification change design changes as well as major changes in processing location of manufacturing applying to goods covered by this Purchase order.
18. All vehicles used for transportation of material should comply to the central motor & vehicle rules act as applicable from time to time. The transporter is required to carry PUC vehicle fitness certificate of transportation vehicle during delivery.
19. Supplier should inform dispatch details immediately after dispatch.
20. Material supplied by seller shall satisfy current Govt. & environmental (ISO 14001-2004) & safety (OHSAS-18001-2007) constraints on restricted toxic & hazardous materials.
21. Supplier shall ensure coverage of transit insurance for material.
22. Supplier shall protect the third party trade secret or proprietary information for material or copy rights supplied by RSB. Failure to do so will result in PO being cancelled with immediate effect.

PAYMENT

1. Payment will be made as stipulated in this order, if the payment is agreed to be made against document through Bank. All bank charges involved shall be borne by the Supplier. Failure by the Supplier to advice his banker to recover all bank charges from supplier. Will result is non-retirement of documents at his own risk and cost.
2. All payments will be done as per applicable RSB policies.
3. No charges for cartage, packing etc., will admissible unless the same is specifically included in our Purchase/ Sub Contract.

SUPPLIER'S QUALITY ASSURANCE

1. All the materials, Component supplied must critically meet RSB Quality standards required as per samples, drawings, specifications or any other related instructions. The supplier shall allow, RSB's employee and authorized representatives for the purpose of inspecting manufacturing and inspection facilities, inspection of raw materials, WIP, FG, machines tools, fixtures jigs or any other items in connection with the manufacture of components for the company.

SAMPLE APPROVAL

1. No supplies should be made prior to the approval of sample unless specifically asked by us. It shall be the responsibility of the Supplier to submit samples well in time to be able to adhere strictly to the delivery schedule.

REJECTIONS

1. The decisions of the company on rejection shall be final and binding on the Supplier and this time clause shall be deemed to constitute an agreement to the contrary under the Sale of Goods Act. The company shall be entitled to reject the materials at any stage, cancel the contract and buy its requirements in the open market against the supplies. There is no rejection allowed unless specifically mentioned in the P.O. clearly.
2. It will be the liability of the Supplier to remove the rejected material within 15 days from our premises at his cost. In case rejection is not taken back within 15 days RSB is not liable to return back the rejection & no compensation will be given. In case of any rework done the components supplied by the suppliers, rework charges, handling charges, disposal charges & any other related charges as applicable will be recovered from Supplier's bill.
3. Rejection must be replaced within the delivery schedule and will be invoiced separately and not as replacement. All charges inclusive of freight and handling on replacements shall be borne by the Supplier.

WARRANTY

1. All the material supplied, should be free from any manufacturing, process defects & should be as per the drawings, Specifications. Any failure at RSB's customer end due to any deviation on quality, supplier shall be responsible for all damages, claims, recovery directly or indirectly claimed to RSB by any agency. Supplier shall reimburse all such expenses to RSB immediately without any delay on any ground. It will be the responsibility of the supplier to provide free replacement of component & assemblies which fail in the field because of material or manufacturing defects during the Warranty period or during the product life cycle, any offered by the company to its customers.

IN THE CASE OF SUB CONTRACT

1. Material Account to be submitted every month with regards to the Receipts & Supply in the prescribed format.
2. The supplier is responsible for safe custody of Company's material including the RAW Material/ Semi Finished/Finished/Tooling.
3. Periodic Physical Verification will be carried out by company's representative. During which supplier should assist in such verification.
4. The supplier has to obtain in writing the quantum to be consumed for each item supplied to him.
5. Supplier is fully responsible for quantity lifted by him till the entire quantity is supplied by him as per specification.
6. The supplier should also return the resultant scrap generated during machining. The remaining material/semi finished/finished held by supplier shall be property of company & company reserves the right to seek for return of raw material in which event the supplier shall return the same forth with.
7. No process rejection is allowed unless specified in PO specifically. In case process rejection, rejected component should be returned back to RSB on a separate delivery challan. All such components should be marked with red paint & to be supplied in a separate batch to avoid mix up. Process rejection exceeding allowed rejection % full cost of raw material shall be recovered. Line rejection at RSB is not considered in the allowed process rejection (if any). Line rejection will be recovered at full cost & rejected components will not be returned back or no scrap benefit will be passed on to supplier.
8. Supplier should ensure coverage of insurance of RSB property on their premises at their own cost.

Checked By

Authorized By

For all queries related to this order contact
www.rsbglobal.com

CORPORATE OFFICE: Ubale Nagar, Nagar Road, Wagoli, Pune, 412207, Tel : 91 20 30642100 Fax : 91 20 30642101



PURCHASE ORDER

Principal Place of Business/Bill To					Supply To					
RSB Transmissions (I) Ltd. (Forging Plant) Plot no. 1007, 1011 P.O. Uchapada Tel : 91674-2550590 Fax : 91674-2550590 Email : ranjan.jena@rsbglobal.com Website : www.rsbglobal.com GSTIN : 21AABCR3925R1Z5 PAN : AABCR3925R State Code & State : 21 ODISHA CIN : U34102PN1989PLC014807					RSB TRANSMISSIONS (I) LTD.(Cuttack) CUTTACK UNIT -1, NH-5,PLOT NO.1011,1007 MANIA,KOTSAHI,TANGI,CHOUDWAR 754022 Tel : 91674-2550590 Fax : 91674-2550590 Email : ranjan.jena@rsbglobal.com Website : www.rsbglobal.com GSTIN : 21AABCR3925R1Z5 PAN : AABCR3925R State Code & State : 21 ODISHA CIN : U34102PN1989PLC014807					
Supplier Details					PO Details					
Supplier Code : 40007025 Name : GRAMTARANG EMPLOYABILITY TRNG SERV P LTD Address : C/O ? CENTURION UNIVERSITY GRAM TARANG EMPLOYABILITY TRAINING SERVICES, AT- RAMACHANDRAPUR,JATANI , BHUBANESWAR Tel : Email : subratkumar.swain@gramtarang.org.in GSTIN : 21AABCC9406C1ZB PAN : AABCC9406C State Code & State : 21 ODISHA					Order Type/Order No : OS / 18000034 Order Date : 08/24/18 Revision No/ Date : 0 / 08/27/18 Quotation No/ Date : Our Reference No. : as per cam sheet Original Order No. : Validity Date : 01/31/19					
No.	Item Code	Drawing No.	HSN	Quantity	Rate	GST Amount/Percentage			Request Date	Amount (Qty x Rate)
	Description	Mod No:	SAC	UOM	Currency	IGST	CGST	SGST		
1	PTRPD1811*OP10 TRIMMER PUNCH D1811		82073000	1.000 EA	3304.80 INR		297.43 @ 9.0 %	297.43 @ 9.0 %	08/24/18	3304.80
2	PTRPD1812*OP10 TRIMMER PUNCH D1812		82073000	1.000 EA	2620.80 INR		235.87 @ 9.0 %	235.87 @ 9.0 %	08/24/18	2620.80
3	PTRPD1809*OP10 TRIMMER PUNCH D1809		82073000	1.000 EA	2998.80 INR		269.89 @ 9.0 %	269.89 @ 9.0 %	08/24/18	2998.80
									Total :	8924.40
									CGST Input@9%	803.20
									SGST Input@9%	803.20
									Other	
									Suspense Account	
									Suspense Setoff Account	
									Grand Total :	10530.79
Grand Total (In Words) : Rupees Ten Thousand Five Hundred Thirty and paise Seventy Nine Only. Delivery Terms : ex-works. Remarks : Payment Terms : 30 Days From Acceptance										

Checked By

Authorized By

For all queries related to this order contact
www.rsbglobal.com

CORPORATE OFFICE: Ubale Nagar, Nagar Road, Wagoli, Pune, 412207, Tel : 91 20 30642100 Fax : 91 20 30642101

TERMS & CONDITIONS**GENERAL**

1. Written acceptance of this PO or Commencement of supply/service against this PO shall constitute acceptance of this Purchase Order.
2. Delivery Challan/Invoice in duplicate should accompany all supplies made mentioning in there clearly supplier code, drawing no., part no., description of material PO no. specified in Purchase/subcontract & quantity supplied.
3. In the case of excisable goods transporter's copy should be send along with material otherwise bill/invoice will be held up. Failure to comply with this & consequent loss of mod vat credit on account of excise duty will be debited to your account where document are routed through bank send the transporter copy along with consent & enclose copy of invoice with document routed through bank. Attested/certified/Photostat copies of transporter's copy of invoice are not acceptable at all.
4. In case of subcontract item with our material failure to supply or return the material within 90 days under rule 4(5)(a) of central excise the excise duty payable in then will be debited to your account.
5. All drawings samples or technical data supplied to you by us shall be kept as secret & shall not be sold or disclosed & these shall be returned to as & when demanded. Failure to comply with this shall make you liable for breach of trust & other actions as may be deemed fit by us.
6. The items manufactured by you from the date furnished by us must not be sold or divulged by you to any other party than ourselves. If you manufacture excess quantity than our order you shall preserve the same for ultimate sale to us on our demand. Alternatively you destroy the goods so manufactured by you. By no account you will sell goods to any other party except with our written consent. The same condition applies to supplies rejected by us parts similar to parts manufactured for us; should not be manufactured by you.
7. No upward revision of price will be permitted during the period of contract unless agreed by us.
8. Terms & condition stated in our purchase/subcontract will be final until the supplier has our written consent to his terms & conditions if any stated in his order acceptance letter.
9. Any letter sent by prepaid registered post to the address given in this order shall be deemed to have been received by party within 3 days of dispatch thereof; irrespective of fact whether the said letter is or is not in fact received by party so addressed.
10. The company reserves the right to cancel & terminate the contract. If prevented by any intervention or control by government authorities or any other cause beyond the control of the company where by company is unable to make use the materials ordered by stoppage suspension of production or otherwise.
11. Local civil court shall have the jurisdiction to try any dispute concerning all our purchase/subcontract.
12. The material should be properly packed to avoid any kind of damage or formation of rust during transportation or storage.
13. Strict adherence to terms of delivery is absolutely essential. The company reserves the right to treat the order as cancelled in the event of your non-compliance of delivery schedule agreed & material will be brought from open market at your risk & cost. Time of delivery shall be essence of contract.
14. Demurrage, penalties etc. shall be levied on account of delay in delivery, dispatch or railway/lorry receipts, advance of invoice & challans or any other shipping documents or for any other reason for which the company is not responsible will be to the supplier's account & recoverable from him.
15. The material must be dispatched by the mode or transport & to the destination mentioned in this order. In case partial suppliers our prior approval must be obtained.
16. If transport arrangement is made by RSB for collection & dispatch of components it will be totally the supplier's risk RSB is not responsible for any shortages damages in such Arrangement supplier should send their representative with each consignment for collection & delivery to ensure safe transit of material.
17. Supplier shall give advance information to buyer in writing for all specification change design changes as well as major changes in processing location of manufacturing applying to goods covered by this Purchase order.
18. All vehicles used for transportation of material should comply to the central motor & vehicle rules act as applicable from time to time. The transporter is required to carry PUC vehicle fitness certificate of transportation vehicle during delivery.
19. Supplier should inform dispatch details immediately after dispatch.
20. Material supplied by seller shall satisfy current Govt. & environmental (ISO 14001-2004) & safety (OHSAS-18001-2007) constraints on restricted toxic & hazardous materials.
21. Supplier shall ensure coverage of transit insurance for material.
22. Supplier shall protect the third party trade secret or proprietary information for material or copy rights supplied by RSB. Failure to do so will result in PO being cancelled with immediate effect.

PAYMENT

1. Payment will be made as stipulated in this order, if the payment is agreed to be made against document through Bank. All bank charges involved shall be borne by the Supplier. Failure by the Supplier to advice his banker to recover all bank charges from supplier. Will result is non-retirement of documents at his own risk and cost.
2. All payments will be done as per applicable RSB policies.
3. No charges for cartage, packing etc., will admissible unless the same is specifically included in our Purchase/ Sub Contract.

SUPPLIER'S QUALITY ASSURANCE

1. All the materials, Component supplied must critically meet RSB Quality standards required as per samples, drawings, specifications or any other related instructions. The supplier shall allow, RSB's employee and authorized representatives for the purpose of inspecting manufacturing and inspection facilities, inspection of raw materials, WIP, FG, machines tools, fixtures jigs or any other items in connection with the manufacture of components for the company.

SAMPLE APPROVAL

1. No supplies should be made prior to the approval of sample unless specifically asked by us. It shall be the responsibility of the Supplier to submit samples well in time to be able to adhere strictly to the delivery schedule.

REJECTIONS

1. The decisions of the company on rejection shall be final and binding on the Supplier and this time clause shall be deemed to constitute an agreement to the contrary under the Sale of Goods Act. The company shall be entitled to reject the materials at any stage, cancel the contract and buy its requirements in the open market against the supplies. There is no rejection allowed unless specifically mentioned in the P.O. clearly.
2. It will be the liability of the Supplier to remove the rejected material within 15 days from our premises at his cost. In case rejection is not taken back within 15 days RSB is not liable to return back the rejection & no compensation will be given. In case of any rework done the components supplied by the suppliers, rework charges, handling charges, disposal charges & any other related charges as applicable will be recovered from Supplier's bill.
3. Rejection must be replaced within the delivery schedule and will be invoiced separately and not as replacement. All charges inclusive of freight and handling on replacements shall be borne by the Supplier.

WARRANTY

1. All the material supplied, should be free from any manufacturing, process defects & should be as per the drawings, Specifications. Any failure at RSB's customer end due to any deviation on quality, supplier shall be responsible for all damages, claims, recovery directly or indirectly claimed to RSB by any agency. Supplier shall reimburse all such expenses to RSB immediately without any delay on any ground. It will be the responsibility of the supplier to provide free replacement of component & assemblies which fail in the field because of material or manufacturing defects during the Warranty period or during the product life cycle, any offered by the company to its customers.

IN THE CASE OF SUB CONTRACT

1. Material Account to be submitted every month with regards to the Receipts & Supply in the prescribed format.
2. The supplier is responsible for safe custody of Company's material including the RAW Material/ Semi Finished/Finished/Tooling.
3. Periodic Physical Verification will be carried out by company's representative. During which supplier should assist in such verification.
4. The supplier has to obtain in writing the quantum to be consumed for each item supplied to him.
5. Supplier is fully responsible for quantity lifted by him till the entire quantity is supplied by him as per specification.
6. The supplier should also return the resultant scrap generated during machining. The remaining material/semi finished/finished held by supplier shall be property of company & company reserves the right to seek for return of raw material in which event the supplier shall return the same forth with.
7. No process rejection is allowed unless specified in PO specifically. In case process rejection, rejected component should be returned back to RSB on a separate delivery challan. All such components should be marked with red paint & to be supplied in a separate batch to avoid mix up. Process rejection exceeding allowed rejection % full cost of raw material shall be recovered. Line rejection at RSB is not considered in the allowed process rejection (if any). Line rejection will be recovered at full cost & rejected components will not be returned back or no scrap benefit will be passed on to supplier.
8. Supplier should ensure coverage of insurance of RSB property on their premises at their own cost.

Checked By

Authorized By

For all queries related to this order contact
www.rsbglobal.com

CORPORATE OFFICE: Ubale Nagar, Nagar Road, Wagoli, Pune, 412207, Tel : 91 20 30642100 Fax : 91 20 30642101



PURCHASE ORDER

Principal Place of Business/Bill To					Supply To						
RSB Transmissions (I) Ltd. (Forging Plant) Plot no. 1007, 1011 P.O. Uchapada Tel : 91674-2550590 Fax : 91674-2550590 Email : ranjan.jena@rsbglobal.com Website : www.rsbglobal.com GSTIN : 21AABCR3925R1Z5 PAN : AABCR3925R State Code & State : 21 ODISHA CIN : U34102PN1989PLC014807					RSB TRANSMISSIONS (I) LTD.(Cuttack) CUTTACK UNIT -1, NH-5,PLOT NO.1011,1007 MANIA,KOTSAHI,TANGI,CHOUDWAR 754022 Tel : 91674-2550590 Fax : 91674-2550590 Email : ranjan.jena@rsbglobal.com Website : www.rsbglobal.com GSTIN : 21AABCR3925R1Z5 PAN : AABCR3925R State Code & State : 21 ODISHA CIN : U34102PN1989PLC014807						
Supplier Details					PO Details						
Supplier Code : 40007025 Name : GRAMTARANG EMPLOYABILITY TRNG SERV P LTD Address : C/O ? CENTURION UNIVERSITY GRAM TARANG EMPLOYABILITY TRAINING SERVICES, AT- RAMACHANDRAPUR,JATANI , BHUBANESWAR Tel : Email : subratkumar.swain@gramtarang.org.in GSTIN : 21AABCC9406C1ZB PAN : AABCC9406C State Code & State : 21 ODISHA					Order Type/Order No : O2 / 18000430 Order Date : 11/03/2019 Revision No/ Date : 0 / 11/03/2019 Quotation No/ Date : Our Reference No. : Original Order No. : Validity Date : 31/03/2019						
No.	Item Code	Drawing No.	HSN	Quantity	Rate	GST Amount/Percentage			Request Date	Amount (Qty x Rate)	
	Description	Mod No:	SAC	UOM	Currency	IGST	CGST	SGST			
1	ZMRS0069 MACHINING CHARGES OF WELDED DIE 2001 BLK BTM		998331	1.000 EA	5364.00 INR		482.76 @ 9.0 %	482.76 @ 9.0 %	03/11/19	5364.00	
2	ZMRS0069 MACHINING CHARGES OF WELDED DIE 2001 FIN TOP		998331	1.000 EA	4971.60 INR		447.44 @ 9.0 %	447.44 @ 9.0 %	03/11/19	4971.60	
3	ZMRS0069 MACHINING CHARGES OF WELDED DIE 2001 FIN BTM		998331	1.000 EA	4824.00 INR		434.16 @ 9.0 %	434.16 @ 9.0 %	03/11/19	4824.00	
4	ZMRS0069 MACHINING CHARGES OF WELDED DIE 2001 BLK TOP		998331	1.000 EA	5043.60 INR		453.92 @ 9.0 %	453.92 @ 9.0 %	03/11/19	5043.60	
									Total :	20203.20	
									CGST Input@9%	1818.29	
									SGST Input@9%	1818.29	
									Other		
									Suspense Account		
									Suspense Setoff Account		
									Grand Total :	23839.78	
Grand Total (In Words) : RUPEES TWENTY THREE THOUSAND EIGHT HUNDRED THIRTY NINE AND PAISE SEVENTY EIGHT ONLY Delivery Terms : EX-WORKS. Remarks : Payment Terms : 30 Days From Acceptance											

Checked By

Authorized By

For all queries related to this order contact
www.rsbglobal.com

CORPORATE OFFICE: Ubale Nagar, Nagar Road, Wagoli, Pune, 412207, Tel : 91 20 30642100 Fax : 91 20 30642101

TERMS & CONDITIONS**GENERAL**

1. Written acceptance of this PO or Commencement of supply/service against this PO shall constitute acceptance of this Purchase Order.
2. Delivery Challan/Invoice in duplicate should accompany all supplies made mentioning in there clearly supplier code, drawing no., part no., description of material PO no. specified in Purchase/subcontract & quantity supplied.
3. In the case of excisable goods transporter's copy should be send along with material otherwise bill/invoice will be held up. Failure to comply with this & consequent loss of mod vat credit on account of excise duty will be debited to your account where document are routed through bank send the transporter copy along with consent & enclose copy of invoice with document routed through bank. Attested/certified/Photostat copies of transporter's copy of invoice are not acceptable at all.
4. In case of subcontract item with our material failure to supply or return the material within 90 days under rule 4(5)(a) of central excise the excise duty payable in then will be debited to your account.
5. All drawings samples or technical data supplied to you by us shall be kept as secret & shall not be sold or disclosed & these shall be returned to as & when demanded. Failure to comply with this shall make you liable for breach of trust & other actions as may be deemed fit by us.
6. The items manufactured by you from the date furnished by us must not be sold or divulged by you to any other party than ourselves. If you manufacture excess quantity than our order you shall preserve the same for ultimate sale to us on our demand. Alternatively you destroy the goods so manufactured by you. By no account you will sell goods to any other party except with our written consent. The same condition applies to supplies rejected by us parts similar to parts manufactured for us; should not be manufactured by you.
7. No upward revision of price will be permitted during the period of contract unless agreed by us.
8. Terms & condition stated in our purchase/subcontract will be final until the supplier has our written consent to his terms & conditions if any stated in his order acceptance letter.
9. Any letter sent by prepaid registered post to the address given in this order shall be deemed to have been received by party within 3 days of dispatch thereof; irrespective of fact whether the said letter is or is not in fact received by party so addressed.
10. The company reserves the right to cancel & terminate the contract. If prevented by any intervention or control by government authorities or any other cause beyond the control of the company where by company is unable to make use the materials ordered by stoppage suspension of production or otherwise.
11. Local civil court shall have the jurisdiction to try any dispute concerning all our purchase/subcontract.
12. The material should be properly packed to avoid any kind of damage or formation of rust during transportation or storage.
13. Strict adherence to terms of delivery is absolutely essential. The company reserves the right to treat the order as cancelled in the event of your non-compliance of delivery schedule agreed & material will be brought from open market at your risk & cost. Time of delivery shall be essence of contract.
14. Demurrage, penalties etc. shall be levied on account of delay in delivery, dispatch or railway/lorry receipts, advance of invoice & challans or any other shipping documents or for any other reason for which the company is not responsible will be to the supplier's account & recoverable from him.
15. The material must be dispatched by the mode or transport & to the destination mentioned in this order. In case partial suppliers our prior approval must be obtained.
16. If transport arrangement is made by RSB for collection & dispatch of components it will be totally the supplier's risk RSB is not responsible for any shortages damages in such Arrangement supplier should send their representative with each consignment for collection & delivery to ensure safe transit of material.
17. Supplier shall give advance information to buyer in writing for all specification change design changes as well as major changes in processing location of manufacturing applying to goods covered by this Purchase order.
18. All vehicles used for transportation of material should comply to the central motor & vehicle rules act as applicable from time to time. The transporter is required to carry PUC vehicle fitness certificate of transportation vehicle during delivery.
19. Supplier should inform dispatch details immediately after dispatch.
20. Material supplied by seller shall satisfy current Govt. & environmental (ISO 14001:2015) (OHSAS 18001:2007) constraints on restricted toxic & hazardous materials.
21. Supplier shall ensure coverage of transit insurance for material.
22. Supplier shall protect the third party trade secret or proprietary information for material or copy rights supplied by RSB. Failure to do so will result in PO being cancelled with immediate effect.

PAYMENT

1. Payment will be made as stipulated in this order, if the payment is agreed to be made against document through Bank. All bank charges involved shall be borne by the Supplier. Failure by the Supplier to advice his banker to recover all bank charges from supplier. Will result in non-retirement of documents at his own risk and cost.
2. All payments will be done as per applicable RSB policies.
3. No charges for cartage, packing etc., will admissible unless the same is specifically included in our Purchase/ Sub Contract.

SUPPLIER'S QUALITY ASSURANCE

1. All the materials, Component supplied must critically meet RSB Quality standards required as per samples, drawings, specifications or any other related instructions. The supplier shall allow, RSB's employee and authorized representatives for the purpose of inspecting manufacturing and inspection facilities, inspection of raw materials, WIP, FG, machines tools, fixtures jigs or any other items in connection with the manufacture of components for the company.

SAMPLE APPROVAL

1. No supplies should be made prior to the approval of sample unless specifically asked by us. It shall be the responsibility of the Supplier to submit samples well in time to be able to adhere strictly to the delivery schedule.

REJECTIONS

1. The decisions of the company on rejection shall be final and binding on the Supplier and this time clause shall be deemed to constitute an agreement to the contrary under the Sale of Goods Act. The company shall be entitled to reject the materials at any stage, cancel the contract and buy its requirements in the open market against the supplies. There is no rejection allowed unless specifically mentioned in the P.O. clearly.
2. It will be the liability of the Supplier to remove the rejected material within 15 days from our premises at his cost. In case rejection is not taken back within 15 days RSB is not liable to return back the rejection & no compensation will be given. In case of any rework done the components supplied by the suppliers, rework charges, handling charges, disposal charges & any other related charges as applicable will be recovered from Supplier's bill.
3. Rejection must be replaced within the delivery schedule and will be invoiced separately and not as replacement. All charges inclusive of freight and handling on replacements shall be borne by the Supplier.

WARRANTY

1. All the material supplied, should be free from any manufacturing, process defects & should be as per the drawings, Specifications. Any failure at RSB's customer end due to any deviation on quality, supplier shall be responsible for all damages, claims, recovery directly or indirectly claimed to RSB by any agency. Supplier shall reimburse all such expenses to RSB immediately without any delay on any ground. It will be the responsibility of the supplier to provide free replacement of component & assemblies which fail in the field because of material or manufacturing defects during the Warranty period or during the product life cycle, any offered by the company to its customers.

IN THE CASE OF SUB CONTRACT

1. Material Account to be submitted every month with regards to the Receipts & Supply in the prescribed format.
2. The supplier is responsible for safe custody of Company's material including the RAW Material/ Semi Finished/Finished/Tooling.
3. Periodic Physical Verification will be carried out by company's representative. During which supplier should assist in such verification.
4. The supplier has to obtain in writing the quantum to be consumed for each item supplied to him.
5. Supplier is fully responsible for quantity lifted by him till the entire quantity is supplied by him as per specification.
6. The supplier should also return the resultant scrap generated during machining. The remaining material/semi finished/finished held by supplier shall be property of company & company reserves the right to seek for return of raw material in which event the supplier shall return the same forth with.
7. No process rejection is allowed unless specified in PO specifically. In case process rejection, rejected component should be returned back to RSB on a separate delivery challan. All such components should be marked with red paint & to be supplied in a separate batch to avoid mix up. Process rejection exceeding allowed rejection % full cost of raw material shall be recovered. Line rejection at RSB is not considered in the allowed process rejection (if any). Line rejection will be recovered at full cost & rejected components will not be returned back or no scrap benefit will be passed on to supplier.
8. Supplier should ensure coverage of insurance of RSB property on their premises at their own cost.

Checked By

Authorized By

For all queries related to this order contact
www.rsbglobal.com

CORPORATE OFFICE: Ubale Nagar, Nagar Road, Wagoli, Pune, 412207, Tel : 91 20 30642100 Fax : 91 20 30642101

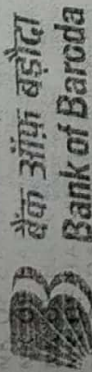

बैंक ऑफ़ बड़ोदा
Bank of Baroda

नाया पल्ली, मोकनेश्र-०५१०१३
NAYAPALLI, BHUBANESWAR-751013
RTGS / NEFT IFSC CODE: BARB0SAVNAY कॅश क्रेडिट खाता / CASH CREDIT ACCOUNT

जारी की गई तारीख से तीन माह के लिए वैध / VALID FOR THREE MONTHS FROM THE DATE OF ISSUE
CBS 01112018
D D M M Y Y Y Y

Or Bearer

Pay GRAMTARANG EMPLOYABILITY TRNG SERV P LTD या धारक को

Rupees रुपये
FORTY EIGHT THOUSAND TWO HUNDRED THIRTY THREE AND
PAISE FORTY FIVE ONLY
₹ ***48,233.45
अदा करें

FOR RSB TRANSMISSIONS I LTD

A/C Payee

खा. सं.
A/c No. 27650500000075

NOT OVER Rupees 48,234.-

भारत की सभी शाखाओं में समतुल्यपर देय
Payable at par at all branches in India

[Handwritten Signature]

Please sign above

CC/2012/SE

॥003438॥ 7510120041 500075॥ 30

Received for [Handwritten Name]

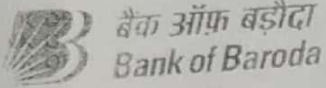

बैंक ऑफ़ बड़ोदा
Bank of Baroda

नाया पल्ली, भोबनेश्र-७५१०१३
NAYAPALLI, BHUBANESWAR-751013
RTGS / NEFT IFSC CODE: BARB0SAVNAY कॅश क्रेडिट खाता / CASH CREDIT ACCOUNT

जारी की गई तारीख से तीन माह के लिए वैध / VALID FOR THREE MONTHS FROM THE DATE OF ISSUE

CBS 2 5 0 1 2 0 1 9
D D M M Y Y Y Y

Or Bearer

Pay GRAMTARAING EMPLOYABILITY TRNG SERV P LTD

या धारक को

Rupees रूपये SIXTY SEVEN THOUSAND ONE HUNDRED FORTY THREE AND PAISE

₹ ***67,143.36

अदा करें

THIRTY SIX ONLY

FOR RSB TRANSMISSIONS I LTD

खा. सं. 27650500000075
A/c No.

A/c Payee

NOT OVER Rs. 67,144/-

Please sign above

CC/2012/SE

भारत की सभी शाखाओं में सममूल्यपर देय BOB
Payable at par at all branches in India

⑈003680⑈ 751012004⑈ 500075⑈ 30

15/08/2018 159679
SESHAASA (K) / CTS - 2010

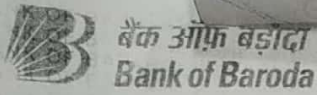

बैंक ऑफ़ बड़ोदा
Bank of Baroda

नाया पल्ली, भोवनेश्वर-७५१०१३

NAYAPALLI, BHUBANESWAR-751013

RTGS / NEFT IFSC CODE: BARB0SAVNAY कॅश क्रेडिट खाता / CASH CREDIT ACCOUNT

CBS

VALID FOR THREE MONTHS FROM THE DATE OF ISSUE
0 5 1 2 2 0 1 8
D D M M Y Y Y Y

Pay GRAMTARANG EMPLOYABILITY TRNG SERV P LTD

Or Bearer

Rupees रुपये TWENTY SEVEN THOUSAND THREE HUNDRED SEVEN AND PAISE ONE

या धारक को

ONLY

अदा करें

₹

***27,307.01

खा. सं.
A/c No.

27650500000075

A/c Payee

FOR RSB TRANSMISSIONS I LTD

NOT OVER Rs. 27,308/-

CC/2012/SE

भारत की सभी शाखाओं में सममूल्यपर देय
Payable at par at all branches in India

BOB

Signature

Please sign above

⑈003498⑈ 751012004⑈ 500075⑈ 30

VALID FOR 3 MONTHS FROM THE DATE OF ISSUE

08012019
D D M M Y Y Y Y

बैंक ऑफ इंडिया
Bank of India
VSS NAGAR Branch, VSS NAGAR ORISSA - 751007
IFSC : BKID0005160

PayGram Tarang Employability Training Services Pvt. Ltd.
या धारक को Or Bearer

रुपये Rupees Six thousand Six hundred thirty Eight only.
₹ 6638/-

चेक नम्बर की शुरुआत (कॉडिंग) Cheque number's ADHAR number (optional)

516020110000115

MECATECH INDIA

For MECATECH INDIA

Autosh K. Mallik
Please sign as Proprietor

PAYABLE AT ALL OUR BRANCHES IN CLEARING

751013031: 000808

VALID FOR 3 MONTHS FROM THE DATE OF ISSUE

08012019
D D M M Y Y Y Y

बैंक ऑफ इंडिया
Bank of India
VSS NAGAR Branch, VSS NAGAR ORISSA - 751007
IFSC : BKID0005160

Pay Gram Tarang Employability Training Services Pvt. Ltd.
या धारक को Or Bearer

रुपये Rupees Nine thousand one hundred twenty five only.
₹ 9125/-

चेक नम्बर की शुरुआत (कॉडिंग) Cheque number's ADHAR number (optional)

516020110000115

MECATECH INDIA

For MECATECH INDIA

Autosh K. Mallik
Please sign as Proprietor

PAYABLE AT ALL OUR BRANCHES IN CLEARING

751013031: 000808



Subrat Kumar Swain <subratkumar.swain@gramtarang.org.in>

GATE MARK

3 messages

K.K STEELS <kksteelsic@rediffmail.com>
To: subratkumar.swain@gramtarang.org.in

Wed, Sep 19, 2018 at 10:20 AM

Dear Sir,
Please find attached the gate position highlight.

Thanks & Regards

M/s K. K. STEELS
Mfg. of : Investment Casting
(Ferrous & Non Ferrous)
An ISO 9001:2008 Certified Company,
Office :- At/Po- Ambica Sahi, Ward No -01,
Ps- Baripada, Dist-Mayurbhanj, 757001 (ODISHA)
Mob :- 094370-33624, 094371-61645,
E-mail : kksteelsic@rediffmail.com.
Web: www.kksteelsic.in

 **KKS-47__48.pdf**
535K

Subrat Kumar Swain <subratkumar.swain@gramtarang.org.in>
To: kksteelsic@rediffmail.com

Sun, Sep 23, 2018 at 6:57 AM

Dear Sir,
Please find the modified gate location and confirm me the same for further processing.

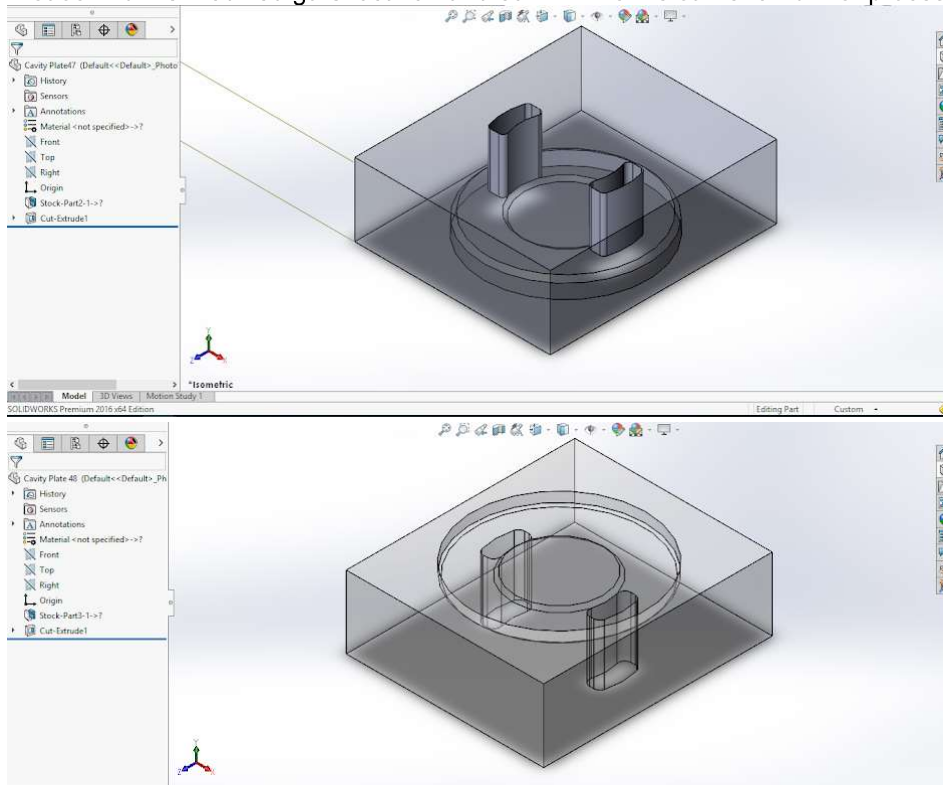

Thanks & Regards

Subrat Kumar Swain

Assistant Manager, CNC Production

Cell:+91-7440019928

+91-8895799659

+91-7008321742

[Quoted text hidden]

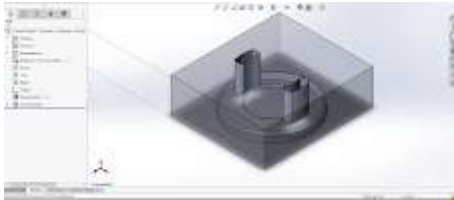
2 attachments**Cavity plate 47.PNG**

229K

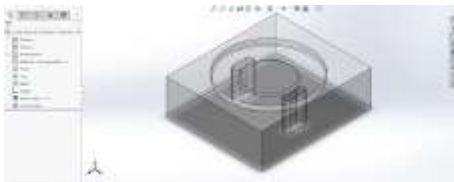
**Cavity plate48.PNG**

222K

K.K STEELS <kksteelsic@rediffmail.com>
To: Subrat Kumar Swain <subratkumar.swain@gramtarang.org.in>

Tue, Sep 25, 2018 at 11:19 AM

Dear Sir,

With due regards, we are conforming the gate location herewith and kindly process the die.

Thanks & Regards

M/s K. K. STEELS
Mfg. of : Investment Casting
(Ferrous & Non Ferrous)
An ISO 9001:2008 Certified Company,
Office :- At/Po- Ambica Sahi, Ward No -01,
Ps- Baripada, Dist-Mayurbhanj, 757001 (ODISHA)
Mob :- 094370-33624, 094371-61645,
E-mail : kksteelsic@rediffmail.com.
Web: www.kksteelsic.in

[Quoted text hidden]





Journal Voucher

No. : JV/03/158

Dated : 31-Mar-2018

Particulars		Amount
Collective for Integrated Livelihood Initiatives	Dr 1,80,000.00	
TDS Receivable (CINI)	Dr 20,000.00	
To Grant in Aid (CINI)		2,00,000.00
CINI Project	2,00,000.00 Cr	
Rs. 2,00,000.00		Rs. 2,00,000.00

On Account of :

Being bill raised towards professional services for the project titled Detailed Livelihood plan of the families for second phase work at Odisha submission of draft report

Authorised Signatory



Prof. Haribandhu Panda, Ph.D.
Vice Chancellor
Centurion University of Technology and Management
Paralakhemundi, Odisha
Mob: +91 – 9861320399, 9337388801

December 29, 2017

Email: <http://www.cutm.ac.in>

Dear Sir,

This is with reference to the ongoing contract with CINI dated September 19, 2017 which will end on 30st December 2017.

We would like to take this opportunity to extend the contract till February 7, 2018. This is due to time required to close the final report. All other terms will remain as per the earlier contract.

Hence, the professional fees for the contract duration would be same i.e. Rs 3,00,000 (Rupees Three Lakh only). CINI will not provide any infrastructural, office, communication, secretarial or other support to you. CINI would provide you with all the necessary materials.

With regards

Yours Sincerely,

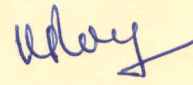
for 

Ganesh Neelam
Executive Director



Receipt Voucher

No. : BR/06/

Dated : 14-Jun-2017

Particulars	Amount
Account : Swabhiman NGO	40,000.00
Through : OBC-04951131001953 (Sahid Nagar)	
On Account of : Being amount received from Swabhiman.	
Amount (in words) : INR Forty Thousand Only	
	Rs. 40,000.00

Authorised Signatory



CENTURION UNIVERSITY OF TECHNOLOGY & MANAGEMENT

At-Ramachandrapur, P.O.-Jatni,
Dist.-Khordha - 752050 (ODISHA)

www.cutm.ac.in

Ph. No. : (0674) 2492186, 2492495

Fax : (0674) 2490480

D/BLR/No.. - 4

RECEIPT

Date : 02/6/2017

Full Name : SWABHIMAN .	Phone No. :
Address : Kalpana chakra, Near Sambalpur University Bhubaneswar, Odisha	Mobile No. : 8984537877
	Email : (Acct#)
	Tax Exemption Required Yes No
	Please provide PAN No.

Currency : INR USD EUR Other Currency

(Please Specify)

Amount : forty thousand only in words : (forty thousand only)
Rs 40000/-

Nationality : Indian Others (Please specify)

By Cheque No. */DD No./Reference No. : 739175 dtd. 2/6/17.

Bank Name & Branch : SBI, Rajpath, Bhubaneswar W. Date : 02/6/17

To Support

Settlement for impact Analysis Study of Project
led by School Management led by SWABHIMAN

Type of Donor : Individual Corporate PSU HUG Trust/Foundation

Sole-Proprietorship Others (Please Specify)

* Cheques are subject to realization

Received Through

Donor Signature

PAN - AAAJC0752B

G-21/2011-12/ Dt. 04.08.2011

12AA-15/2011-12/ Dt. 04.08.2011



schools to respond to these challenges will not only depend on school leadership, but academic and supplementary support provided by the State Government and local

State Bank Of India

(07188)-RAJPATH(BHUBANESWAR)
75, BUDHANAGAR,
BHUBANESWAR, ORISSA 751006
Tel : 764 2311390 Fax : IFS Code : SBIN0007188 SWIFT :

VALID FOR 3 MONTHS ONLY
02062017

Centurion University of Technology & Management
ES Forty thousand only.

अदा करें ₹ 40000/-

1642583208

VALID UPTO ₹ 10 LACS AT NON-HOME BRANCH

SB ACCOUNT
PREFIX :
1515700023

Mohit K. Mahapatra
Treasurer
Swabhiman

Pratik Mahapatra
General Secretary
Swabhiman

CHEQUE Payable at Par at All Branches of SBI

⑈ 739175⑈ 751002015⑈ 004461⑈ 31

Centurion University (Jatni)-2015-16

Ramachandrapur, Jatni, Khurda

Odisha

E-Mail : cfo@cutm.ac.in

Journal VoucherNo. : **JV/01/88**

Dated : 31-Jan-2016

Particulars	Debit	Credit
DST Project Receivable <i>Dr</i>	71,000.00	
<i>To</i> Grant-in-Aid (DST) DST Project 71,000.00 <i>Cr</i>		71,000.00
	₹ 71,000.00	₹ 71,000.00

On Account of :being the grant from DST
Project receivable against
the expenses

Authorised Signatory



CENTURION UNIVERSITY OF TECHNOLOGY & MANAGEMENT

D/BLR/No. 16

At-Ramachandrapur, P.O.-Jatni,
Dist.-Khordha - 752050 (ODISHA)
www.cutm.ac.in
Ph. No. : (0674) 2492186, 2492495
Fax : (0674) 2490480

RECEIPT

Date: 27/8/12

Full Name: EDITI (DST-NIMAD)	Phone No.:
Address: Project - 2018-19. Ahmedabad.	Mobile No.:
	Email:
	Tax Exemption Required Yes No
	Please provide PAN No.

Currency: INR USD EUR Other Currency

(Please Specify)

To Conduct EAC (5)

Amount:

Rs 80000/-

In words:

Eighty thousand/-

Nationality: Indian Others (Please specify)

By Cheque No. */DD No./Reference No.:

Ad to OBC-1953 on 27/8/12

Bank Name & Branch:

OBC - Ahmedabad

Date:

To Support

To Conduct EAC (5)

Type of Donor: Individual Corporate PSU HUG Trust/Foundation

Sole-Proprietorship

Others (Please Specify)

* Cheques are subject to realization

Received Through

Bank - 1953 (OBC)

Donor Signature

PAN - AAAJC0752B

80G-21/2011-12/ Dt. 04.08.2011

12AA-15/2011-12/ Dt. 04.08.2011



Centurion University



Centurion University of
Technology & Management



ENTREPRENEURSHIP DEVELOPMENT INSTITUTE OF INDIA

Near Village Bhat, Via Ahmedabad Airport & Indira Bridge, P.O. Bhat - 382 428, Dist. : Gandhinagar, Gujarat, India.

Tel. : +91-79-23969153, 23969158, 23969159, 23969161

E-mail : info@ediindia.org

Telefax : +91-79-23969164

Website : www.ediindia.org

S. B. Sareen

Sr. Faculty & Project Director: DST-NIMAT

EDII/DST-NIMAT/18-19/017

Date: 03/07/2018

SPEED POST

Prof. (Dr.) Haribandhu Panda

Vice Chancellor

Centurion University of Technology and Management (CUTM)

At - Ramchandrapur, P.O. Jatni

District: Khurda

Bhubaneswar - 752 050

Odisha

Kind Attention: Prof. Umakanta Nayak, Asst. Prof., School of Management & Camp
Coordinator

Dear Sir,

Sub: DST-NIMAT Project 2018-19: Sanction Order

Greetings from EDII, Ahmedabad!

This is with reference to your proposal submitted for conducting activities / programme(s) under the aegis of National Science & Technology Entrepreneurship Development Board (NSTEDB), Department of Science and Technology, Govt. of India, New Delhi.

We are happy to inform you that the following activities / programmes have been sanctioned:

Sr. No.	Activity / Programme	No.	Amount in Rs.	Locations
1	Entrepreneurship Awareness Camp (EAC)	5	100000	As mentioned in proposal
	Total	5	100000	

You are requested to please go through the enclosed **Guidelines / Terms & Conditions** as it is **mandatory to follow the same.**

Please note that the **first installment is to be released on receipt of the following documents:**

1. Duly Signed Agreement
2. Duly Signed "Terms & Conditions" (each Page)
3. Action Plan [Annexure-I]
4. Bank Details [Annexure-IA]



The funds will be transferred through RTGS/NEFT. Please make sure that the above said documents must reach us as early as possible, but not later than **ONE MONTH** of receiving this sanction letter. Non receipt of the same may be considered as your unwillingness to take up the programme(s).

As per point no. 11 of the enclosed Terms & Conditions, it is expected to generate results in terms of unit establishment from programmes like; EDP, WEDP and TEDP. Hope, you will design the required strategy to show case desired result.

For any additional information, please contact either me (Email ID: sareen@ediindia.org, Mobile: 09925110040) or my colleague Mr. Prakash Solanki (Email ID: psolanki@ediindia.org, Mobile: 09723816384).

We look forward to have a long term professional relationship.

Thanking you, with regards,

(S. B. Sareen)

Encl.: a. a

INDIAN INCOME TAX RETURN ACKNOWLEDGEMENT

[Where the data of the Return of Income in Form ITR-1 (SAHAJ), ITR-2, ITR-3, ITR-4, ITR-5, ITR-6, ITR-7 filed and verified electronically]

Assessment Year
2019-20

PERSONAL INFORMATION AND THE ACKNOWLEDGEMENT NUMBER	Name			CENTURION SCIENCE AND TECHNOLOGY ENTERPRENEURSHIP FACILITATION CENTRE		PAN AAECC7721R	
	Flat/Door/Block No	Name Of Premises/Building/Village			Form Number.	ITR-7	Status AOP/BOI
	AT ALLURI NAGAR	R SITAPUR					
	Road/Street/Post Office	Area/Locality					
	VIA UPPALADA	PARLAKHEMUNDI			Filed u/s		139(1)-On or before due date
	Town/City/District	State	Pin/ZipCode				
	BEHERAMPUR	ORISSA	761211				
	Assessing Officer Details (Ward/Circle)		EXEMPTION WARD, BERHAMPUR				
	e-filing Acknowledgement Number		181049111280919				
	COMPUTATION OF INCOME AND TAX THEREON	1	Gross total income			1	0
2		Total Deductions under Chapter-VI-A			2	0	
3		Total Income			3	0	
3a		Deemed Total Income under AMT/MAT			3a	0	
3b		Current Year loss, if any			3b	0	
4		Net tax payable			4	0	
5		Interest and Fee Payable			5	0	
6		Total tax, interest and Fee payable			6	0	
7		Taxes Paid	a	Advance Tax	7a	0	
			b	TDS	7b	0	
	c		TCS	7c	0		
	d		Self Assessment Tax	7d*	0		
	e		Total Taxes Paid (7a+7b+7c +7d)	7e	0		
8	Tax Payable (6-7e)			8	0		
9	Refund (7e-6)			9	0		
10	Exempt Income	Agriculture		10	0		
		Others					

Income Tax Return submitted electronically on 28-09-2019 12:36:13 from IP address 117.197.251.78 and verified byDR.MUKTI KANTA MISHRA having PAN ADOPM0255A on 28-09-2019 12:36:13 from IP address 117.197.251.78 using **Digital Signature Certificate (DSC)**DSC details: 16187183CN=e-Mudhra Sub CA for Class 2 Individual 2014,OU=Certifying Authority,O=eMudhra Consumer Services Limited,C=IN**DO NOT SEND THIS ACKNOWLEDGEMENT TO CPC, BENGALURU**

	referred to in section 11(2)(b)(ii) or section 11(2)(b)(iii), or	
(c)	has not been utilised for purposes for which it was accumulated or set apart during the period for which it was to be accumulated or set apart, or in the year immediately following the expiry thereof? If so, the details thereof	No

II. APPLICATION OR USE OF INCOME OR PROPERTY FOR THE BENEFIT OF PERSONS REFERRED TO IN SECTION 13(3)

1.	Whether any part of the income or property of the institution was lent, or continues to be lent, in the previous year to any person referred to in section 13(3) (hereinafter referred to in this Annexure as such person)? If so, give details of the amount, rate of interest charged and the nature of security, if any.	No
2.	Whether any part of the income or property of the institution was made, or continued to be made, available for the use of any such person during the previous year? If so, give details of the property and the amount of rent or compensation charged, if any.	No
3.	Whether any payment was made to any such person during the previous year by way of salary, allowance or otherwise? If so, give details	No
4.	Whether the services of the institution were made available to any such person during the previous year? If so, give details thereof together with remuneration or compensation received, if any	No
5.	Whether any share, security or other property was purchased by or on behalf of the institution during the previous year from any such person? If so, give details thereof together with the consideration paid	No
6.	Whether any share, security or other property was sold by or on behalf of the institution during the previous year to any such person? If so, give details thereof together with the consideration received	No
7.	Whether any income or property of the institution was diverted during the previous year in favour of any such person? If so, give details thereof together with the amount of income or value of property so diverted	No
8.	Whether the income or property of the institution was used or applied during the previous year for the benefit of any such person in any other manner? If so, give details	No

III. INVESTMENTS HELD AT ANY TIME DURING THE PREVIOUS YEAR(S) IN CONCERNS IN WHICH PERSONS REFERRED TO IN SECTION 13(3) HAVE A SUBSTANTIAL INTEREST

S. No	Name and address of the concern	Where the concern is a company, number and class of shares held	Nominal value of the investment(₹)	Income from the investment(₹)	Whether the amount in col. 4 exceeded 5 per cent of the capital of the concern during the previous year-say, Yes/No
Total					

Place **BHUBANESWA**

R

Date **08/10/2018**

Name
Membership Number
FRN (Firm Registration Number)
Address

BIBEKANANDA MOHANTY
056264
310009E
SRB & ASSOCIATES 5TH FL
OOR IDCO TOWER JANPAT
H, BHUBANESWAR

Form Filing Details	
Revision/Original	Original

FORM NO. 10B

[See rule 17B]

Audit report under section 12A(b) of the Income-tax Act, 1961, in the case of charitable or religious trusts or institutions

We have examined the balance sheet of CENTURION SCIENCE AND TECHNOLOGY ENTREPRENEURSHIP FACILITY CENTRE, AT-ALLURI NAGAR, R SITAPUR, UPPALADA PARALAKHEMUNDI, AAECC7721R [name and PAN of the trust or institution] as at 31/03/2019 and the Profit and loss account for the year ended on that date which are in agreement with the books of account maintained by the said trust or institution.

We have obtained all the information and explanations which to the best of our knowledge and belief were necessary for the purposes of the audit. In our opinion, proper books of account have been kept by the head office and the branches of the abovenamed institution visited by us so far as appears from our examination of the books, and proper Returns adequate for the purposes of audit have been received from branches not visited by us, subject to the comments given below:

NIL

In our opinion and to the best of our information, and according to information given to us, the said accounts give a true and fair view-

(i) in the case of the balance sheet, of the state of affairs of the above named institution as at 31/03/2019 and

(ii) in the case of the profit and loss account, of the profit or loss of its accounting year ending on 31/03/2019

The prescribed particulars are annexed hereto.

Place BHUBANESWADate 08/10/2018

Name BIBEKANANDA MOHANTY
 Membership Number 056264
 FRN (Firm Registration Number) 310009E
 Address SRB & ASSOCIATES 5TH FL
OOR IDCO TOWER JANPAT
H, BHUBANESWAR

ANNEXURE

Statement of particulars

I. APPLICATION OF INCOME FOR CHARITABLE OR RELIGIOUS PURPOSES

1.	Amount of income of the previous year applied to charitable or religious purposes in India during that year (₹)	20235129
2.	Whether the <u>institution</u> has exercised the option under clause (2) of the Explanation to section 11(1) ? If so, the details of the amount of income deemed to have been applied to charitable or religious purposes in India during the previous year (₹)	No
3.	Amount of income accumulated or set apart for application to charitable or religious purposes, to the extent it does not exceed 15 per cent of the income derived from property held under trust wholly for such purposes. (₹)	No.
4.	Amount of income eligible for exemption under section 11(1)(c) (Give details)	No
5.	Amount of income, in addition to the amount referred to in item 3 above, accumulated or set apart for specified purposes under section 11(2) (₹)	0
6.	Whether the amount of income mentioned in item 5 above has been invested or deposited in the manner laid down in section 11(2)(b) ? If so, the details thereof.	Not Applicable
7.	Whether any part of the income in respect of which an option was exercised under clause (2) of the Explanation to section 11(1) in any earlier year is deemed to be income of the previous year under section 11(1B) ? If so, the details thereof (₹)	No
8.	Whether, during the previous year, any part of income accumulated or set apart for specified purposes under section 11(2) in any earlier year-	
(a)	has been applied for purposes other than charitable or religious purposes or has ceased to be accumulated or set apart for application thereto, or	No
(b)	has ceased to remain invested in any security referred to in section 11(2)(b)(i) or deposited in any account	No



e-Filing *Anywhere Anytime*
Income Tax Department, Government of India

ACKNOWLEDGEMENT OF RECEIPT OF FORM (Other Than ITR)

Name	CENTURION SCIENCE AND TECHNOLOGY ENTERPRENEURSHIP FACILITATION CENTRE	PAN	AAECC7721R
Form No	10B	Assessment Year	2019-20
e-Filing Acknowledgement Number	181043301280919	Date of e-Filing	28/09/2019

*For and on behalf of,
e-Filing Administrator*

(This is a computer generated Acknowledgment Receipt and needs no signature)

[Click to Print the Receipt](#)

[Click here to Close the window](#)



SRB & Associates
CHARTERED ACCOUNTANTS

5TH FLOOR, IDCO TOWER, JANAPATH,
BHUBANESWAR - 751 022, ODISHA
TEL : 0674 - 2541043, 2545880
FAX : 91- 674 - 2546414
Email: srbbsr@rediffmail.com

JAJPUR ROAD - 06726-220345
NEW DELHI - 011-51601983
KOLKATA - 033-30930975
SECUNDERABAD - 040-27510739

Independent Auditor's Report

To the Members of CENTURION SCIENCE AND TECHNOLOGY ENTREPRENEURSHIP FACILITATION CENTRE

Report on the Standalone Financial Statements

Opinion

We have audited the standalone financial statements of **CENTURION SCIENCE AND TECHNOLOGY ENTREPRENEURSHIP FACILITATION CENTRE**. ("The Company"), which comprise of the Balance Sheet as at 31st March 2019, and the statement of Income & Expenditure for the period ended on that date, and notes to the financial statements, including a summary of significant accounting policies and other explanatory information.

In our opinion and to the best of our information and according to the explanations given to us, the aforesaid standalone financial statements give the information required by the Companies Act, 2013 in the manner so required and give a true and fair view in conformity with the accounting principles generally accepted in India, of the state of affairs of the Company as at March 31, 2019, its excess of expenditure over income for the period ended on that date.

Basis for Opinion

We conducted our audit in accordance with the Standards on Auditing (SAs) specified under section 143(10) of the Companies Act, 2013. Our responsibilities under those Standards are further described in the *Auditor's Responsibilities for the Audit of the Financial Statements* section of our report. We are independent of the Company in accordance with the *Code of Ethics* issued by the Institute of Chartered Accountants of India together with the ethical requirements that are relevant to our audit of the financial statements under the provisions of the Companies Act, 2013 and the Rules there under, and we have fulfilled our other ethical responsibilities in accordance with these requirements and the *Code of Ethics*. We believe that the audit evidence we have obtained is sufficient and appropriate to provide a basis for our opinion.





Information Other than the Standalone Financial Statements and Auditor's Report Thereon

The Company's Board of Directors is responsible for the preparation of the other information. The other information comprises the information included in the Management Discussion and Analysis, Board's Report including Annexure to Board's Report, Business Responsibility Report, Corporate Governance and Shareholder's Information, but does not include the standalone financial statements and our auditor's report thereon.

Our opinion on the standalone financial statements does not cover the other information and we do not express any form of assurance conclusion thereon.

In connection with our audit of the standalone financial statements, our responsibility is to read the other information and, in doing so, consider whether the other information is materially inconsistent with the standalone financial statements or our knowledge obtained during the course of our audit or otherwise appears to be materially misstated.

If, based on the work we have performed, we conclude that there is a material misstatement of this other information; we are required to report that fact. We have nothing to report in this regard.

Responsibilities of Management and Those Charged with Governance for the Standalone Financial Statements

The Company's Board of Directors is responsible for the matters stated in section 134(5) of the Companies Act, 2013 ("the Act") with respect to the preparation of these standalone financial statements that give a true and fair view of the financial position, financial performance, (changes in equity) and cash flows of the Company in accordance with the accounting principles generally accepted in India, including the accounting Standards specified under section 133 of the Act. This responsibility also includes maintenance of adequate accounting records in accordance with the provisions of the Act for safeguarding of the assets of the Company and for preventing and detecting frauds and other irregularities; selection and application of appropriate accounting policies; making judgments and estimates that are reasonable and prudent; and design, implementation and maintenance of adequate internal financial controls, that were operating effectively for ensuring the accuracy and completeness of the accounting records, relevant to the preparation and presentation of the financial statements that give





a true and fair view and are free from material misstatement, whether due to fraud or error.

In preparing the financial statements, the Board of Directors is responsible for assessing the Company's ability to continue as a going concern, disclosing, as applicable, matters related to going concern and using the going concern basis of accounting unless the Board of Directors either intends to liquidate the Company or to cease operations, or has no realistic alternative but to do so.

Those Board of Directors are also responsible for overseeing the company's financial reporting process.

Auditor's Responsibilities for the Audit of the Financial Statements

Our objectives are to obtain reasonable assurance about whether the financial statements as a whole are free from material misstatement, whether due to fraud or error, and to issue an auditor's report that includes our opinion. Reasonable assurance is a high level of assurance, but is not a guarantee that an audit conducted in accordance with SAs will always detect a material misstatement when it exists. Misstatements can arise from fraud or error and are considered material if, individually or in the aggregate, they could reasonably be expected to influence the economic decisions of users taken on the basis of these financial statements.

Report on Other Legal and Regulatory Requirements

1. As required by the Companies (Auditor's Report) Order, 2016 ("the Order"), issued by the Central Government of India in terms of sub-section (11) of section 143 of the Companies Act, 2013, is not applicable .

2. As required by Section 143(3) of the Act, we report that:

a) We have sought and obtained all the information and explanations which to the best of our knowledge and belief were necessary for the purposes of our audit.

(b) In our opinion, proper books of account as required by law have been kept by the Company so far as it appears from our examination of those books.





(c) The Balance Sheet and the Statement of income and Expenditure dealt with by this Report are in agreement with the relevant books of account.

(d) In our opinion, the aforesaid standalone financial statements comply with the Accounting Standards specified under Section 133 of the Act, read with Rule 7 of the Companies (Accounts) Rules, 2014.

(e) On the basis of the written representations received from the directors as on 31st March, 2019 taken on record by the Board of Directors, none of the directors is disqualified as on 31st March, 2019 from being appointed as a director in terms of Section 164(2) of the Act.

(f) With respect to the adequacy of the internal financial controls over financial reporting of the Company and the operating effectiveness of such controls, refer to our separate report in "Annexure-A" and

(g) With respect to the other matters to be included in the Auditor's Report in accordance with Rule 11 of the Companies (Audit and Auditors) Rules, 2014, in our opinion and to the best of our information and according to the explanations given to us:

i. The Company has disclosed the impact of pending litigations on its financial position in its financial statements.

ii. The Company did not have any long-term contracts including derivative contracts for which there were any material foreseeable losses.

iii. There are no amounts which are required to be transferred to the Investor Education and Protection Fund by the Company.

For SRB & Associates
Chartered Accountants
Firm Regn. No: 310009E

K.P Swain

K.P Swain
Partner
M.N-306323

Bhubaneswar
7th September 2019

UDIN: 19306323AAAA3M6848





Annexure "A" to the Independent Auditor's report of even date on the Standalone Financial Statements as at and for the year ended 31st March 2019 of CENTURION SCIENCE AND TECHNOLOGY ENTREPRENEURSHIP FACILITATION CENTRE

Report on the Internal Financial Controls under Clause (i) of Sub-section 3 of Section 143 of the Companies Act, 2013 ("the Act")

We have audited the internal financial controls over financial reporting of **CENTURION SCIENCE AND TECHNOLOGY ENTREPRENEURSHIP FACILITATION CENTRE** ("the Company") as of 31st March, 2019 in conjunction with our audit of the standalone financial statements of the Company for the year ended on that date.

Management's Responsibility for Internal Financial Controls

The Company's management is responsible for establishing and maintaining internal financial controls based on the internal control over financial reporting criteria established by the Company considering the essential components of internal control stated in the Guidance Note on Audit of Internal Financial Controls over Financial Reporting issued by the Institute of Chartered Accountants of India. These responsibilities include the design, implementation and maintenance of adequate internal financial controls that were operating effectively for ensuring the orderly and efficient conduct of its business, including adherence to company's policies, the safeguarding of its assets, the prevention and detection of frauds and errors, the accuracy and completeness of the accounting records, and the timely preparation of reliable financial information, as required under the Companies Act, 2013.

Auditors' Responsibility

Our responsibility is to express an opinion on the Company's internal financial controls over financial reporting based on our audit. We conducted our audit in accordance with the Guidance Note on Audit of Internal Financial Controls Over Financial Reporting (the "Guidance Note") and the Standards on Auditing, issued by ICAI and deemed to be prescribed under section 143(10) of the Companies Act, 2013, to the extent applicable to an audit of internal financial controls, both applicable to an audit of Internal Financial Controls and, both issued by the Institute of Chartered Accountants of India. Those Standards and the Guidance Note require that we comply with ethical requirements and plan and perform the audit to obtain reasonable assurance about whether adequate internal financial controls over financial reporting was established and maintained and if such controls operated effectively in all material respects.





Our audit involves performing procedures to obtain audit evidence about the adequacy of the internal financial controls system over financial reporting and their operating effectiveness. Our audit of internal financial controls over financial reporting included obtaining an understanding of internal financial controls over financial reporting, assessing the risk that a material weakness exists, and testing and evaluating the design and operating effectiveness of internal control based on the assessed risk. The procedures selected depend on the auditor's judgment, including the assessment of the risks of material misstatement of the standalone financial statements, whether due to fraud or error.

We believe that the audit evidence we have obtained is sufficient and appropriate to provide a basis for our audit opinion on the Company's internal financial controls system over financial reporting.

Meaning of Internal Financial Controls Over Financial Reporting

A company's internal financial control over financial reporting is a process designed to provide reasonable assurance regarding the reliability of financial reporting and the preparation of standalone financial statements for external purposes in accordance with generally accepted accounting principles. A company's internal financial control over financial reporting includes those policies and procedures that (1) pertain to the maintenance of records that, in reasonable detail, accurately and fairly reflect the transactions and dispositions of the assets of the company; (2) provide reasonable assurance that transactions are recorded as necessary to permit preparation of financial statements in accordance with generally accepted accounting principles, and that receipts and expenditures of the company are being made only in accordance with authorisations of management and directors of the company; and (3) provide reasonable assurance regarding prevention or timely detection of unauthorised acquisition, use, or disposition of the company's assets that could have a material effect on the standalone financial statements.

Inherent Limitations of Internal Financial Controls over Financial Reporting

Because of the inherent limitations of internal financial controls over financial reporting, including the possibility of collusion or improper management override of controls, material misstatements due to error or fraud may occur and not be detected. Also, projections of any evaluation of the internal financial controls over financial reporting to future periods are subject to the risk that the internal financial control over financial reporting may become inadequate because of changes in conditions, or that the degree of compliance with the policies or procedures may deteriorate.





SRB & Associates

CHARTERED ACCOUNTANTS
Opinion

In our opinion, the Company has, in all material respects, an adequate internal financial controls system over financial reporting and such internal financial controls over financial reporting were operating effectively as at 31st March, 2019, based on the internal control over financial reporting criteria established by the Company considering the essential components of internal control stated in the Guidance Note on Audit of Internal Financial Controls Over Financial Reporting issued by the Institute of Chartered Accountants of India.

**For SRB & Associates
Chartered Accountants
Firm Regn. No: 310009E**

K.P Swain

**K.P Swain
Partner
M.N-306323**

**Bhubaneswar
7th September 2019**



CENTURION SCIENCE AND TECHNOLOGY ENTREPRENEURSHIP FACILITATION CENTRE
At-Alluri Nagar,PO-R.Sitapur,Uppalada,Parlakhemundi,Gajapati,Odisha
Incorporated under section 8 of Companies Act,2013
A company limited by share
Balance Sheet as at 31st March 2019

SL NO	PARTICULARS	NOTES	AS AT 31 MARCH 2019 (₹)	AS AT 31 MARCH 2018 (₹)
I	EQUITY AND LIABILITIES			
1	Shareholders' funds			
	(a) Share capital	2	1,000,000.00	1,000,000.00
	(b) Reserves and surplus	3	797,304.47	7,224,159.36
2	Non-current liabilities			
	(a) Long-term borrowings			
	(b) Other long-term liabilities			
3	Current liabilities			
	(a) Short Term Borrowing	4	5,084,556.00	5,015,630.00
	(b) Trade Payable		817,556.00	478,849.00
	(c) Other current liabilities	5	522,074.00	659,467.00
	Total		8,221,490.47	14,378,105.36
II	ASSETS			
1	Non-current assets			
	(a) Fixed assets	6		
	(i) Tangible assets		7,588,876.96	8,255,749.50
	(ii) Intangible asset		84,229.00	69,830.00
	(iii) Capital work in progress		-	-
	(b) Long-term loans and advances			
	(c) Other non-current assets	7	-	-
2	Current assets			
	(a) Cash and cash equivalents	8	161,071.51	5,334,194.86
	(b) Trade receivables		255,678.00	262,934.00
	(b) Short-term loans and advances		2,435.00	38,050.00
	(c) Other current assets	9	129,200.00	417,347.00
	Total		8,221,490.47	14,378,105.36

Accompanying Notes forming part of the financial statements

1

For SRB & Associates
Chartered Accountants
F.Regd. No.310009E

K.P Swain

K.P SWAIN
Partner
M. No.306323



Bhubaneswar
7th September 2019

**For Centurion Science and Technology
Entrepreneurship Facilitation Centre**

M.K. Mishra

Dr. M.K. Mishra
Director

D.N. Rao

Prof. D.N. Rao
Director

CENTURION SCIENCE AND TECHNOLOGY ENTREPRENEURSHIP FACILITATION CENTRE
At-Alluri Nagar, PO-R.Sitapur, Uppalada, Parlakhemundi, Gajapati, Odisha
 Incorporated under section 8 of Companies Act, 2013
 A company limited by share
Statement of Income and Expenditure as at 31st march 2019

SL NO	PARTICULARS	NOTES	FOR THE YEAR ENDED MARCH 31, 2019 (₹)	FOR THE YEAR ENDED MARCH 31, 2018 (₹)
I)	INCOME			
	Revenue from operations	10	19,881,735.24	40,693,166.37
	Other income	11	353,394.00	975,102.00
	TOTAL INCOME		20,235,129.24	41,668,268.37
II)	EXPENDITURE			
	Employee benefits expenses	12	2,980,180.00	2,640,246.00
	Training Expenses	13	20,807,944.00	33,078,677.25
	Depreciation & Amortization expenses	6	1,502,516.46	
	Less: Transferred from Capital Grants (Matching amount of depreciation on assets acquired from capital grant)		(469,966.44)	
	Other expenses	14	1,032,550.01	259,339.70
			1,371,343.96	1,942,746.48
	TOTAL EXPENSES		26,192,017.97	37,921,009.43
III)	Surplus \ (Deficit) Before exceptional and extraordinary items and tax (I-II)		(5,956,888.73)	3,747,258.94
IV)	Exceptional items		-	-
V)	Surplus \ (Deficit) Before extraordinary items and tax (III-IV)		(5,956,888.73)	3,747,258.94
VI)	Extraordinary items		-	-
VII)	Surplus \ (Deficit) Before Tax (V-VI)		(5,956,888.73)	3,747,258.94
VIII)	TAX EXPENSES			
	(a) Current tax		-	-
IX)	Surplus \ (Deficit) for the period from continuing operations (VII-VIII)		(5,956,888.73)	3,747,258.94
X)	Surplus \ (Deficit) from discontinuing operations		-	-
XI)	Tax expense of discontinuing operations		-	-
XII)	Surplus \ (Deficit) from Discontinuing operations (after tax)		-	-
XIII)	Surplus \ (Deficit) for the period		(5,956,888.73)	3,747,258.94

Accompanying Notes forming part of the financial statements

For SRB & Associates
 Chartered Accountants
 F.Regd. No.310009E

K Swain

K.P SWAIN
 Partner
 M. No.306323

Bhubaneswar
 7th September 2019



For Centurion Science and Technology
 Entrepreneurship Facilitation Centre

M.K. Mishra

Dr. M.K. Mishra
 Director

D.N. Rao

Prof. D.N. Rao
 Director

Centurion Science & Technology Entrepreneurship Facilitation Centre

At-Alluri Nagar,Po-R.Sitapur,Uppalada,Parlakhemundi, Gajapati,Odisha-761211

Note-1

1. Corporate Information.

CENTURION SCIENCE AND TECHNOLOGY ENTREPRENEURSHIP FACILITATION CENTRE is a Non-Profit making company domiciled in India. The Company engaged in improving the quality of life of the poor or otherwise underprivileged rural and urban people, by providing a complete range of financial and non-financial services so as to facilitate their growth and development into financially sustainable entities.

2. Basis of Accounting

These financial statements are prepared in accordance with Indian Generally Accepted Accounting Principles (GAAP) under the historical cost convention on accrual basis except for certain financial instruments which are measured at fair values. GAAP comprises mandatory Accounting standards as prescribed under Section 133 of the Companies Act., 2013, read With Rule 7 of the Companies (Accounting) Rules, 2014 the provisions of the Act (to the extent Notified) .Accounting policies have been consistently applied except where a newly issued Accounting standard is initially adopted or a revision to an existing accounting standard requires a change in the accounting policy hitherto in use.

SIGNIFICANT ACCOUNTING POLICIES

1. Revenue Recognition

Revenue is recognized to the extent that it is probable that the economic benefits will flow to the Company and the revenue can be reliably measured. Any grant received is recognized as and when they are received.

2. Use of Estimates

The preparation of financial statements are in conformity with the generally accepted accounting principles which requires estimates and assumptions to be made, that affects the reported amounts of assets and liabilities on the date of financial statements and the reported amount of revenues and expenses during the reported period.



3. Tangible Fixed Assets

Fixed Assets are stated at cost, net of accumulated depreciation and accumulated impairment losses, if any. The cost comprises purchase price, borrowing costs, if capitalization criteria are met and directly attributable cost of bringing the asset to its working condition for the intended use. Any subsidy/ reimbursement/ contribution received for installation and acquisition of any fixed assets is transferred to capital grant account.

Capital work- in progress is stated at cost if any.

Subsequent expenditure related to an item of fixed assets is added to its book value only if it increases the future benefits from the existing asset beyond its previously assessed standard of performance. All other expenses on existing fixed assets, including day-to-day repairs and maintenance expenditure and cost of replacing parts, are charged to the Statement of Income and Expenditure Account for the period during which such expenses are incurred.

4. Depreciation on fixed assets

Depreciation is provided on WDV Method over the period of assets after keeping 5% of cost as residual value and in the manner prescribed in the Companies Act, 2013. Depreciation on assets purchased/ acquired during the year is charged from the date of Purchase of the assets.

In respect of Addition/Deletion/Transfer of Fixed Assets depreciation is provided on proportionate basis for the period during which the assets are put to use in the company.

5. Intangible Assets

Intangible assets acquired separately are measured on initial recognition at cost. Following initial Recognition, intangible assets are carried at cost less accumulated amortization and accumulated Impairment losses, if any.

6. Capital Grant

Any amount received as capital grant/donations/contributions either from domestic source for construction of building and acquisition of assets for augmenting the objective of the company is transferred to Capital Grant Account. Matching amount of depreciation on grant asset transferred to Capital Grant Account.



NOTES FORMING PART OF ACCOUNTS

15. Provisions for taxation have not been made in accounts as the company has been registered under Section 12AA of the Income Tax Act 1961.
16. Related party Disclosure- As required by accounting Standard-18, " Related Party Disclosure"

Enterprise where there is significant influence (Where transaction Exist)

Particular of Related Party	<u>Current Year</u>	<u>Previous Year</u>
Centurion University of Technology & Management (Closing Balance)	50,84,556.00	50,15,630.00

17. Previous year figures have been re-grouped/re-arranged confirming to current year's presentation.

For SRB & Associates
Chartered Accountants
F.Regd. No.310009E

K.P. Swain

K.P Swain
Partner
M. No.306323

Bhubaneswar
Date:-07th September 2019



**For Centurion Science and Technology
Entrepreneurship Facilitation Centre**

M.K. Mishra

Dr. M.K. Mishra
Director

D.N. Rao

Prof. D.N. Rao
Director

Notes to Financial Statement

Note No.2 : Share capital

PARTICULARS	AS AT 31 MARCH 2019		AS AT 31 MARCH 2018	
	NUMBERS		NUMBERS	
AUTHORISED				
Equity shares of ₹ 10 each	100,000	1,000,000.00	100,000	1,000,000.00
ISSUED, SUBSCRIBED & FULLY PAID UP				
Equity shares of ₹ 10 each	100,000	1,000,000.00	100,000	1,000,000.00
TOTAL	100,000	1,000,000.00	100,000	1,000,000.00

(a) Reconciliation of the number of shares and amount outstanding as at the beginning and at the end of the year.

PARTICULARS	AS AT 31 MARCH 2019		AS AT 31 MARCH 2018	
	NUMBERS		NUMBERS	
i) Shares outstanding at the beginning of the financial year.	100,000	1,000,000.00	10,000	100,000.00
ii) Bonus Shares Issued during the year	-	-	-	-
ii) Equity shares Issued during the year			90,000	900,000.00
OUTSTANDING AS AT THE END OF THE YEAR	100,000	1,000,000	100,000	1,000,000.00

(b) Details of shareholders holding more than 5% of the shares in the company

PARTICULARS	AS AT 31 MARCH 2019		AS AT 31 MARCH 2018	
	NUMBERS	% OF HOLDING	NUMBERS	% OF HOLDING
Mukti Kanta Mishra	5,000	5%	5,000	5%
Dechiraju Narasimha Rao	5,000	5%	5,000	5%
Centurion University of Technology & Management (represented by Mr Mukti Kanta Mishra)	90,000	90%	90,000	0.90
TOTAL	100,000	100%	100,000	100%

Note No.3: Reserves and surplus

PARTICULARS	AS AT MARCH 31, 2019 (₹)	AS AT MARCH 31, 2018 (₹)
Reserve and Surplus consist of		
a) Capital Reserve		
Grant in aid		
Grant from BMC	5,130,942.28	5,723,018.28
Grant others	28,300.41	28,300.41
Grant from Mindtree	13,983.75	56,573.98
Less: Transferred from Capital Grants (Matching amount of depreciation on assets acquired from capital grant)	(469,966.44)	(634,666.52)
TOTAL	4,703,260.00	5,173,226.15
b) Surplus/ (Deficit)		
Excess of expenditure over income		
Opening balance	2,050,933.21	(1,696,325.74)
Surplus(Deficit) for the year	(5,956,888.73)	3,747,258.94
TOTAL	(3,905,955.53)	2,050,933.21
SUB TOTAL	797,304.47	7,224,159.36

Note No.4: Short Term Borrowings

	AS AT MARCH 31, 2019 (₹)	AS AT MARCH 31, 2018 (₹)
Interest Free borrowings (Unsecured)	5,084,556.00	5,015,630.00
TOTAL	5,084,556.00	5,015,630.00

Note No.5: Other current liabilities

	AS AT MARCH 31, 2019 (₹)	AS AT MARCH 31, 2018 (₹)
Other Liabilities *	521,528.00	444,455.00
Statutory Dues Payable	546.00	215,012.00
TOTAL	522,074.00	659,467.00

* Other Liabilities includes liabilities for expenses and salary wages payable .



	AS AT MARCH 31,2019 (₹)	AS AT MARCH 31,2018 (₹)
Note 7:- Other Non Current Assets		
Preliminary Expenses	-	-
Pre-operative Expenses	-	-
TOTAL	-	-

Note No.8: Cash and Bank balance

	AS AT MARCH 31,2019 (₹)	AS AT MARCH 31,2018 (₹)
Cash and cash equivalent		
Cash-in-hand	370.00	16,586.00
Balance with banks	-	-
-In saving bank account	160,701.51	5,317,608.86
TOTAL	161,071.51	5,334,194.86

Note No.9: Other Current Asset

	AS AT MARCH 31,2019 (₹)	AS AT MARCH 31,2018 (₹)
Deposits (Asset)		
Security Deposit	100,380.00	366,380.00
TDS Receivable	28,820.00	28,820.00
Prepaid Insurance	-	22,147.00
TOTAL	129,200.00	417,347.00



Notes to Financial Statement
Note No.10: Revenue from Operation

PARTICULARS	FOR THE YEAR ENDEED MARCH 31,2019 (₹)	FOR THE YEAR ENDEED MARCH 31,2018 (₹)
Training Income	9,998,281.24	6,516,275.59
Grant & Donation	9,883,454.00	34,176,890.78
TOTAL	19,881,735.24	40,693,166.37

Note No.11: Other Income

PARTICULARS	FOR THE YEAR ENDEED MARCH 31,2019 (₹)	FOR THE YEAR ENDEED MARCH 31,2018 (₹)
Miscellaneous income	353,394.00	975,102.00
TOTAL	353,394.00	975,102.00

Note No.12: Employee benefits expenses

PARTICULARS	FOR THE YEAR ENDEED MARCH 31,2019 (₹)	FOR THE YEAR ENDEED MARCH 31,2018 (₹)
Salaries & Wages	2,980,180.00	2,640,246.00
TOTAL	2,980,180.00	2,640,246.00

Note No.13: Training Expenses

PARTICULARS	FOR THE YEAR ENDEED MARCH 31,2019 (₹)	FOR THE YEAR ENDEED MARCH 31,2018 (₹)
Training Expenses		
Training Expenses	20,807,944.00	33,078,677.25
TOTAL	20,807,944.00	33,078,677.25

Note No.14: Other expenses

PARTICULARS	FOR THE YEAR ENDEED MARCH 31,2019 (₹)	FOR THE YEAR ENDEED MARCH 31,2018 (₹)
Bank Charges	18,556.96	20,958.77
Electricity Charges	281,725.00	382,631.00
External Linkage/internet	8,984.00	71,308.00
Legal & Consultancy	48,710.00	24,200.00
Office Expenses	474,602.00	479,622.00
Printing & Stationery	59,265.00	62,929.00
Registration Charges	7,000.00	41,800.00
Rent rate & taxes	15,850.00	16,000.00
Repair & Maintenance	47,786.00	336,827.00
Communication Related Expenses	39,615.00	7,159.00
Travelling & conveyance	276,740.00	450,457.71
Audit fee	26,550.00	26,550.00
Insurance	65,960.00	22,304.00
TOTAL	1,371,343.96	1,942,746.48



CENTURION SCIENCE AND TECHNOLOGY ENTREPRENEURSHIP FACILITATION CENTRE
Notes to financial statement

NOTE : 6

S.No	PARTICULARS	GROSS BLOCK			DEPRECIATION			NET BLOCK			
		Balance as on 01.04.2018 (₹)	Additions (₹)	Sale Transfer (₹)	Balance as on 31.03.2019 (₹)	Upto 31.03.2018 (₹)	depreciation during the year (₹)	Sale Transfer (₹)	depreciation up to Mar 2019 (₹)	Closing balance (₹)	Closing balance (₹)
	A. TANGIBLE ASSETS										
1	Building	1,348,633.00	-	-	1,348,633.00	244,588.57	104,884.22	-	349,472.79	999,160.21	31,03,2018
2	Computer	348,249.00	7,150.00	-	355,399.00	80,326.74	170,741.51	-	251,068.25	104,330.75	1,104,044.00
3	Electrical Installation	346,783.00	39,000.00	-	385,783.00	167,628.86	54,387.45	-	222,016.31	163,766.69	267,922.00
4	Furniture & Fixture	553,410.00	30,001.00	-	583,411.00	64,459.99	133,356.25	-	197,816.24	385,594.76	179,154.00
5	vehicle	95,200.00	144,088.00	-	239,288.00	81.45	30,568.51	-	30,649.96	208,638.04	488,950.00
6	Machine & Equipment	1,380,279.00	485,193.00	-	1,865,472.00	516,737.00	190,962.56	-	707,699.56	1,157,772.44	95,119.00
7	Office Equipment	840,467.00	103,310.00	-	943,777.00	206,444.27	320,747.85	-	527,192.12	416,584.88	863,542.00
	Category	4,913,021.00	808,742.00	-	5,721,763.00	1,280,266.90	1,005,648.35	-	2,285,915.25	3,435,847.75	3,632,754.00
	B. INTANGIBLE ASSETS										
	Intangible Asset	130,500.00	41,300.00	-	171,800.00	60,669.52	26,901.66	-	87,571.00	84,229.00	69,830.00
		5,043,521.00	850,042.00	-	5,893,563.00	1,340,936.41	1,032,550.01	-	2,373,486.25	3,520,076.75	3,702,584.00

ASSETS ACQUIRED OUT OF CAPITAL GRANT

S.No	PARTICULARS	GROSS BLOCK			DEPRECIATION			NET BLOCK			
		Balance as on 01.04.2018 (₹)	Additions (₹)	Sale Transfer (₹)	Balance as on 31.03.2019 (₹)	Upto 31.03.2018 (₹)	depreciation during the year (₹)	Sale Transfer (₹)	depreciation up to Mar 2019 (₹)	Closing balance (₹)	Closing balance (₹)
	TANGIBLE ASSETS										
1	Building	6,623,805.50	-	-	6,623,805.50	2,233,642.38	425,277.96	-	2,658,920.34	3,964,885.16	31,03,2018
2	Computer	281,865.00	-	-	281,865.00	281,080.93	-	-	281,080.93	784.07	4,390,163.50
3	Furniture & Fixture	86,601.00	-	-	86,601.00	52,098.97	8,932.58	-	61,031.54	25,569.46	784.00
4	Machine & Equipment	469,413.00	-	-	469,413.00	284,398.56	33,487.61	-	317,886.17	151,526.83	34,502.00
5	Vehicle	86,000.00	-	-	86,000.00	73,468.01	2,268.29	-	75,736.30	10,263.70	185,014.00
		7,547,684.50	-	-	7,547,684.50	2,924,688.85	469,966.44	-	3,394,655.29	4,153,029.21	12,532.00
											4,622,995.50



CENTURION SCIENCE AND TECHNOLOGY ENTREPRENEURSHIP FACILITATION CENTRE
Paralakhemundi

ASSESSMENT YEAR, 2018- 2019
PREVIOUS YEAR ENDED 31.03.2018

NOTE REGARDING COMPLIANCE OF SEC.11 OF THE INCOME TAX ACT.,1961

<u>INCOME</u>	<u>Amount (₹)</u>
As per Statement of Income	20,235,129
Add:- Capital Grant received during the year	-
Un utilised Grant	-
TOTAL	<u>20,235,129</u>
<u>Amount to be applied for Charitable purposes in India</u>	
85% of the Income	17,199,860
Amount not exceeding 15% of the Income,	<u>3,035,269</u>
	<u>20,235,129</u>
<u>Amount actually applied for Charitable purposes</u>	
As per Statement of Application of Income	20,235,129
Add:- Addition to Fixed Assets & Capital Work In Progress	850,042
Deficit as per Income & Expenditure Account	-
Less:- Surplus as per Income & Expenditure Account	(5,956,889)
Depreciation	1,502,516
	<u>25,539,544</u>
Amount accumulated U/s.11(2) for specific purpose	NIL
Amount not exceeding 15% of the Income, accumulated U/s.11 (1) (a)	-
TOTAL	<u>-</u>

Note: As more than 85% of the Income has been applied for charitable purpose provisions of **Sec 11** have been complied with.Hence the institute is entitled to exemption form tax U/S 11.



CENTURION SCIENCE AND TECHNOLOGY ENTREPRENEURSHIP FACILITATION CENTRE
Paralakhemundi

ASSESSMENT YEAR, 2019-20
PREVIOUS YEAR ENDED 31.03.2019

NOTE REGARDING COMPLIANCE OF SEC.11 OF THE INCOME TAX ACT.,1961

INCOME

	<u>Amount (Rs.)</u>	
Total Income as per Income & Expenditure Account	20,235,129.24	
add : Capital Grant Received	-	
add : Un utilised grant received	-	
		20,235,129.24

EXPENDITURE

Total expenditure as per income & Expenditure Account	26,192,017.97		
Adjustment (Less)			
1 Outstanding Expenses	521,528.00		
2 Provision for doubtful loans	-		
3 Prepaid expenses last years	22,147.00		
4 Depreciation	1,032,550.01		
5 Interest on term loan payable	-		
6 TDS payable	-		
	<hr/>	1,576,225.01	
Adjustment (ADD)			
Opening outstanding Expenses	659,467.00		
Adjustment (ADD)		659,467.00	
			25,275,259.96
1 Prepaid expenses	-		
2 Fixed Asset	<hr/>	850,042.00	850,042.00
			26,125,301.96

Income		20,235,129.24
	85%	17,199,859.85
Expenditure		26,125,301.96
up to 15%		-
U/S11(2) Accumulation		0.00



PURCHASE ORDER

ORIGINAL COPY



CENTRAL TOOL ROOM & TRAINING CENTRE

(A Government of India Society, Ministry of MSME)

B-36, CHANDKA INDUSTRIAL AREA, BHUBANESWAR - 751 024, ODISHA

Phone : Direct (0674) 3011710 (Purchase)

Fax : 91-674-2743061, Email : cttc@cttc.gov.in, Website : www.cttcbsr.co.in

ISO-9001, ISO-14001
OHSAS-18001
ISO-29990

M/s Gram Tarang Employability Training Services Private Limited
J.I.T.M Campus, Aluri Nagar, R.Sitapur
Paralakhemundi - 761211
Ph No: +91 891 6587657, 09437619974

Purchase/Work Order No.: - 1803040
Date: - 18.08.2018
Our Tender Enquiry No.: - As per N.S Approval
Date: - 06.08.2018
Your Ref. No.: - Nil
Date: - Nil
Indentor: - ARD

The undersigned is pleased to order the followings/accepts your tender mentioned above for supplies/services as detailed in the schedule below subject to terms and conditions mentioned under and over leaf herewith.

Sl. No.	Articles/Services to be supplied	Quantity	Unit	Unit Price		Amount	
				Rs.	P.	Rs.	P.
	Machining of Components						
1	Pressure Port 151510PD060 (TU/ML)	850	Ncs.	530.00		450500.00	
2	Clamping Ring (ADAPTOR) 120112PD090 (Milling)	26	Ncs.	860.00		22360.00	
3	Mounting Head 150910PD020 (TU/ML)	200	Ncs.	550.00		110000.00	
<p>Material shall be supplied By CTTC, Bhubaneswar Other Terms & Condition as per Enclosed Annex-I & Attached Checklist for the Supplier.</p> <p>Criteria of Acceptance: Approval of Sample & CTTC Inspection Report.</p> <p>OUR GST No: 21AAABC0056G1ZI As per GST rule two copies of invoice is to be furnished for release of payment.</p>							

Total in Words : (Rupees Five lakh eighty two thousand eight hundred and eighty) **582860.00**

TERMS & CONDITIONS

- | | |
|--------------------------------------|---|
| 1. Sales Tax : | GST : Extra as applicable |
| 2. Excise Duty : | nil |
| 3. Octroi Duty : | nil |
| 4. Any other Taxes / Duties if any : | nil |
| 5. Insurance : | nil |
| 6. Packing / Forwarding : | nil |
| 7. Mode of Transport and Charges : | nil |
| 8. Delivery Schedule | Delivery : As per Mutually agreed delivery schedule. |
| 9. Terms of Payment | Payment : Within 30 days of delivery & acceptance of items. |

Date -

Managing Director/
Authorised Official

PURCHASE ORDER

ORIGINAL COPY



CENTRAL TOOL ROOM & TRAINING CENTRE

(A Government of India Society, Ministry of MSME)

B-36, CHANDKA INDUSTRIAL AREA, BHUBANESWAR - 751 024, ODISHA

Phone : Direct (0674) 3011710 (Purchase)

Fax : 91-674-2743061, Email : cttc@cttc.gov.in, Website : www.cttcbsr.co.in

ISO-9001, ISO-14001
OHSAS-18001
ISO-29990

M/s Gram Tarang Employability Training Services Private Limited
J.I.T.M Campus, Aluri Nagar, R.Sitapur
Paralakhemundi - 761211
Ph No: +91 891 6587657, 09437619974

Purchase/Work Order No.: - 1803055
Date :- 24.09.2018
Our Tender Enquiry No.: - Enq by Prod. Committee (ST)
Date :- 09.09.2018
Your Ref. No.: - nil
Date :- 09.09.2018
Indenter :- SMP

The undersigned is pleased to order the followings/accepts your tender mentioned above for supplies/services as detailed in the schedule below subject to terms and conditions mentioned under and over leaf herewith.

Sl. No.	Articles/Services to be supplied	Quantity	Unit	Unit Price		Amount	
				Rs.	P.	Rs.	P.
<u>Machining of Components:-</u>							
1	Top Cover (DRG No-FIL-03-5051 , C)	100	Nos	450.00		45000.00	
2	Bottom Cover (DRG No-FIL-03-5052-C)	100	Nos	200.00		20000.00	
3	Top Cover (DRG No-FIL-04-5051,C)	100	Nos	450.00		45000.00	
4	Bottom Cover (DRG No-FIL-04-5052,C)	100	Nos	200.00		20000.00	
5	Top Cover (DRG No-FIL-05-5051,C)	100	Nos	450.00		45000.00	
6	Bottom Cover (DRG No-FIL-05-5052,C)	100	Nos	200.00		20000.00	
Other terms & condition as per enclosed Annex-II & attached Checklist for the supplier.							
<u>Criteria of Acceptance:</u>							
Approval of Sample & CTTC Inspection Report.							
Material shall be supplied by CTTC BBSR.							

Total in Words : (Rupees One lakh ninety five thousand Only)

In Figures : 195000.00

TERMS & CONDITIONS

- Sales Tax : Price Inclusive of GST (GST To be should be shown separately)
- Excise Duty : nil
- Octroi Duty : nil
- Any other Taxes / Duties if any : nil
- Insurance : nil
- Packing / Forwarding : nil
- Mode of Transport and Charges : nil
- Delivery Schedule : nil
- Terms of Payment : Delivery - Within 30 Days of receipt of material.
Payment - Within 30 days of delivery and acceptance of items.

Date -

Managing Director/
Authorised Official

PURCHASE ORDER

ORIGINAL COPY



CENTRAL TOOL ROOM & TRAINING CENTRE

(A Government of India Society, Ministry of MSME)

B-36, CHANDKA INDUSTRIAL AREA, BHUBANESWAR - 751 024, ODISHA

Phone : Direct (0674) 3011710 (Purchase)

Fax : 91-674-2743061, Email : cttc@cttc.gov.in, Website : www.cttcbbbsr.co.in

ISO-9001, ISO-14001
OHSAS-18001
ISO-29990

M/s Gram Tarang Employability Training Services Private Limited
J.I.T.M Campus, Aluri Nagar, R.Sitapur
Paralakhemundi - 761211
Ph No: +91 891 6587657, 09437619974

Purchase/Work Order No.: - 1703007

Date: - 01.05.2017

Our Tender Enquiry No. Enq by Prod. Committee (LT)

Date: - 25.04.2017

Your Ref. No.: - nil

Date: - 18.04.2017

Indentor: - ANP

The undersigned is pleased to order the followings/accepts your tender mentioned above for supplies/services as detailed in the schedule below subject to terms and conditions mentioned under and over leaf herewith.

Sl. No.	Articles/Services to be supplied	Quantity	Unit	Unit Price		Amount	
				Rs.	P.	Rs.	P.
Machining of Components:-							
1	Top Cover (FIL-01-5051/FIL-03-0003)	20	Nos	450.00		9000.00	
2	Bottom Cover (FIL-01-5052/FIL-03-0003)	20	Nos	200.00		4000.00	
3	Top Cover (FIL-01-5051/FIL-04-0004)	20	Nos	450.00		9000.00	
4	Bottom Cover (FIL-01-5052/FIL-04-0004)	20	Nos	200.00		4000.00	
<p>Other terms & condition as per enclosed Annex-II & attached Checklist for the supplier.</p> <p>Criteria of Acceptance: Approval of Sample & CTTC Inspection Report.</p> <p>Material shall be supplied by CTTC BBSR.</p>							

(Rupees Twenty Six Thousand Only)

26000.00

Total in Words :

In Figures :

TERMS & CONDITIONS

Price Inclusive of All Taxes (Taxes should be shown separately)

- Sales Tax : nil
- Excise Duty : nil
- Octroi Duty : nil
- Any other Taxes / Duties if any : nil
- Insurance : nil
- Packing / Forwarding : nil
- Mode of Transport and Charges : nil
- Delivery Schedule
- Terms of Payment

Delivery - Within 30 Days of receipt of material.

Payment - Within 30 days of delivery and acceptance of items.

Managing Director /
Authorised Official

Date -

PURCHASE ORDER

ORIGINAL COPY



CENTRAL TOOL ROOM & TRAINING CENTRE

(A Government of India Society, Ministry of MSME)

B-36, CHANDKA INDUSTRIAL AREA, BHUBANESWAR - 751 024, ODISHA

Phone : Direct (0674) 3011710 (Purchase)

Fax : 91-674-2743061, Email : cttc@cttc.gov.in, Website : www.cttcbbbsr.co.in

ISO-9001, ISO-14001
OHSAS-18001
ISO-29990
1703022

M/s Gram Tarang Employability Training Services Private Limited
J.I.T.M Campus, Aluri Nagar, R.Sitapur
Paralakhemundi - 761211
Ph No: +91 891 6587657, 09437619974

Purchase/Work Order No.: -

07.06.2017

Date :-

Repeat Order (LT)

Our Tender Enquiry No.:-

1703007/01.05.2017

Date :-

Your Ref. No.:-

nil

Date :-

18.04.2017

Indentor :-

ANP

The undersigned is pleased to order the followings/accepts your tender mentioned above for supplies/services as detailed in the schedule below subject to terms and conditions mentioned under and over leaf herewith.

Sl. No.	Articles/Services to be supplied	Quantity	Unit	Unit Price		Amount	
				Rs.	P.	Rs.	P.
Machining of Components:-							
1	Top Cover (FIL-01-5051/FIL-04-0004)	20	Nos	450.00		9000.00	
2	Bottom Cover (FIL-01-5052/FIL-04-0004)	20	Nos	200.00		4000.00	
<p>Other terms & condition as per enclosed Annex-II & attached Checklist for the supplier.</p> <p>Criteria of Acceptance: Approval of Sample & CTTC Inspection Report.</p> <p>Material shall be supplied by CTTC BBSR.</p>							
Total in Words : (Rupees Thirteen Thousand Only)						13000.00	
Total in Words :				In Figures :			

TERMS & CONDITIONS

- Sales Tax :
- Excise Duty :
- Octroi Duty :
- Any other Taxes / Duties if any :
- Insurance :
- Packing / Forwarding :
- Mode of Transport and Charges :
- Delivery Schedule
- Terms of Payment

Price Inclusive of All Taxes (Taxes should be shown separately)

nil

nil

nil

nil

nil

nil

Delivery - Within 30 Days of receipt of material.

Payment - Within 30 days of delivery and acceptance of items.

Managing Director/
Authorised Official

Date -

PURCHASE ORDER

.. ORIGINAL COPY



सूक्ष्म लघु एवं मध्यम उद्यम
MICRO, SMALL & MEDIUM ENTERPRISES

CENTRAL TOOL ROOM & TRAINING CENTRE

(A Government of India Society, Ministry of MSME)

B-36, CHANDKA INDUSTRIAL AREA, BHUBANESWAR - 751 024, ODISHA

Phone : Direct (0674) 3011710 (Purchase)

Fax : 91-674-2743061, Email : cttc@cttc.gov.in, Website : www.cttcbsr.co.in



ISO-9001, ISO-14001
OHSAS-18001
ISO-29990

M/s Gram Tarang Employability Training Services Private Limited
J.I.T.M Campus, Aluri Nagar, R.Sitapur
Paralakhemundi - 761211
Ph No: +91 891 6587657, 09437619974

Purchase/Work Order No.: - 1603080
Date: - 20.12.2016
Our Tender Enquiry No.: - Committee Recommended
Date :- nil
Your Ref. No.: - nil
Date :- 06.12.2016
Indentor :- AKP

The undersigned is pleased to order the followings/accepts your tender mentioned above for supplies/services as detailed in the schedule below subject to terms and conditions mentioned under and over leaf herewith.

Sl. No.	Articles/Services to be supplied	Quantity	Unit	Unit Price		Amount	
				Rs.	P.	Rs.	P.
1	Housing(B)	64	Nos	340.00		21760.00	
2	C.Ring(B&S)	96	Nos	355.00		34080.00	
3	Housing(V)	8	Nos	345.00		2760.00	
4	C.Ring(V)	8	Nos	165.00		1320.00	
5	Housing(S)	32	Nos	340.00		10880.00	
6	Cover(CRC)	32	Nos	1100.00		35200.00	

Other terms & condition as per enclosed Annex-I & attached Checklist for the supplier.
Criteria of Acceptance:
Approval of Sample & CTTC Inspection Report.

Material shall be supplied by CTTC, BBSR.

Total in Words : (Rupees One lakhs Six Thousand Only)

In Figures :

106000.00

TERMS & CONDITIONS

- | | |
|--------------------------------------|---|
| 1. Sales Tax : | Service Tax - Extra. |
| 2. Excise Duty : | nil |
| 3. Octroi Duty : | nil |
| 4. Any other Taxes / Duties if any : | nil |
| 5. Insurance : | nil |
| 6. Packing / Forwarding : | nil |
| 7. Mode of Transport and Charges : | nil |
| 8. Delivery Schedule | Delivery - Within 30 Days of receipt of material. |
| 9. Terms of Payment | Payment - Within 30 days of delivery and acceptance of items. |

Date -

General Manager/
Authorised Official

PURCHASE ORDER

ORIGINAL COPY



सूक्ष्म लघु एवं मध्यम उद्यम
MICRO, SMALL & MEDIUM ENTERPRISES

CENTRAL TOOL ROOM & TRAINING CENTRE

(A Government of India Society, Ministry of MSME)

B-36, CHANDKA INDUSTRIAL AREA, BHUBANESWAR - 751 024, ODISHA

Phone : Direct (0674) 3011710 (Purchase)

Fax : 91-674-2743061, Email : ctcc@ctcc.gov.in, Website : www.ctccbbsr.co.in



ISO-9001, ISO-14001
OHSAS-18001
ISO-29990

M/s Gram Tarang Employability Training Services Private Limited
J.I.T.M Campus, Aluri Nagar, R.Sitapur
Paralakhemundi - 761211
Ph No: +91 891 6587657, 09437619974

Purchase/Work Order No.: - 1603046
Date: 08.09.2016
Our Tender Enquiry No.: Enq. By Prod. Committee (LT)
Date :- 01.09.2016
Your Ref. No.: - GTET/PKD/008
Date :- 01.09.2016
Indentor :- A.Rashid

The undersigned is pleased to order the followings/accepts your tender mentioned above for supplies/services as detailed in the schedule below subject to terms and conditions mentioned under and over leaf herewith.

Sl. No.	Articles/Services to be supplied	Quantity	Unit	Unit Price		Amount		
				Rs.	P.	Rs.	P.	
1	Machining of Components Punch as per our Drg. No: V5/PT/0064	300	Nos	125.00		37500.00		
2	Housing Lower Half as per our Drg No: 1001204-A	65	Nos	1500.00		97500.00		
Other terms & condition as per enclosed Annex-I & attached Checklist for the supplier . <u>Criteria of Acceptance:</u> Approval of Sample and CTTC Inspection								

Total in Words : (Rupees One Lakh Thirty Five Thousand Only) In Figures : 135000.00

TERMS & CONDITIONS

- Sales Tax :
- Excise Duty :
- Octroi Duty :
- Any other Taxes / Duties if any :
- Insurance :
- Packing / Forwarding :
- Mode of Transport and Charges :
- Delivery Schedule
- Terms of Payment

Price inclusive of all taxes (Taxes should be shown separately)

nil

nil

nil

nil

nil

FOR CTTC BBSR

Delivery: Within 30 days of receipt of material.

Payment : Within 15 days of delivery and acceptance of items.

Date -

General Manager
Authorized Official

Central Tool Room & Training Centre
Bhubaneswar

PURCHASE ORDER

INDENT COPY



CENTRAL TOOL ROOM & TRAINING CENTRE

(A Government of India Society, Ministry of MSME)
B-36, CHANDKA INDUSTRIAL AREA, BHUBANESWAR - 751 024, ODISHA
Phone : Direct (0674) 3297116 (Purchase)
Fax : 91-674- 2743061, Email : cttc@satyam.net.in, Website : www.cttcbsr.co.in



M/s Gram Tarang Employability Training Services Private Limited
J.I.T.M. Campus, Aluri Nagar
R.Sitapur, Paralakhemundi - 761211
Ph No: +91 891 6587657 / 09437619974

Purchase/Work Order No.: - 1603009
Date: - 29.04.2016
Our Tender Enquiry No: - Enq by Prod. Committee(LT)
Date :- 27.04.2016
Your Ref. No.: - GTET/PKD/004
Date :- 23.04.2016
Indentor :- KVK

The undersigned is pleased to order the followings/accepts your tender mentioned above for supplies/services as detailed in the schedule below subject to terms and conditions mentioned under and over leaf herewith.

Sl. No.	Articles/Services to be supplied	Quantity	Unit	Unit Price Rs. P.	Amount Rs. P.
1	Bellow Support As per Our Enclosed Drawing - I Drawing No : 15 12 28 PD 02 01 Other terms & condition as per enclosed Annex-I & attached Checklist for the supplier. Criteria of Acceptance: Sample to be Approved & CTTC Inspection Report	650	Nos	150.00	97500.00

Total in Words: (Rupees Ninety Seven Thousand Five Hundred Only) In Figures : 97,500.00

TERMS & CONDITIONS

- Sales Tax : Price inclusive of All Taxes (VAT should be shown separately)
- Excise Duty : nil
- Octroi Duty : nil
- Any other Taxes / Duties if any : nil
- Insurance : nil
- Packing / Forwarding : nil
- Mode of Transport and Charges : nil
- Delivery Schedule : Delivery - Within 30 Days of receipt of material.
- Terms of Payment : Payment - Within 15 days of acceptance of items

General Manager/
Authorised Official

Date -

Indentor's Signature
Date.....

PURCHASE ORDER

ORIGINAL COPY



CENTRAL TOOL ROOM & TRAINING CENTRE

(A Government of India Society, Ministry of MSME)

B-36, CHANDKA INDUSTRIAL AREA, BHUBANESWAR - 751 024, ODISHA

Phone : Direct (0674) 3011710 (Purchase)

Fax : 91-674-2743061, Email : cttc@cttc.gov.in, Website : www.cttcbsr.co.in

ISO-9001, ISO-14001
OHSAS-18001
ISO-29990

M/s Gram Tarang Employability Training Services Private Limited
J.I.T.M Campus, Aluri Nagar, R.Sitapur
Paralakhemundi - 761211
Ph No: +91 891 6587657, 09437619974

Purchase/Work Order No.: - 1603075
Date 16.12.2016
Our Tender Enquiry No.: - TE-55 (LT)
Date :- 29.06.2016
Your Ref. No.: - nil
Date :- nil
Indentor :- A.Rashid

The undersigned is pleased to order the followings/accepts your tender mentioned above for supplies/services as detailed in the schedule below subject to terms and conditions mentioned under and over leaf herewith.

Sl. No.	Articles/Services to be supplied	Quantity	Unit	Unit Price		Amount	
				Rs.	P.	Rs.	P.
1	Machining of Components as per Enclosed annexure-I						226095.00
<p>Other terms & condition as per enclosed Annex-II & attached Checklist for the supplier</p> <p>Criteria of Acceptance: Approval of Sample & CTTC Inspection Report.</p> <p>Material shall be supplied by CTTC BBSR.</p>							

Total in Words : (Rupees Two Lakh Twenty Six Thousand Ninety Five Only)

226095.00

TERMS & CONDITIONS

- Sales Tax :
- Excise Duty :
- Octroi Duty :
- Any other Taxes / Duties if any :
- Insurance :
- Packing / Forwarding :
- Mode of Transport and Charges :
- Delivery Schedule
- Terms of Payment

Price Inclusive of All Taxes (Taxes should be shown separately)

nil

nil

nil

nil

nil

nil

Delivery - Within 30 Days of receipt of material.

Payment - Within 30 days of delivery and acceptance of items.

General Manager/
Authorised Official

Date -

PURCHASE ORDER

ORIGINAL COPY



CENTRAL TOOL ROOM & TRAINING CENTRE

(A Government of India Society, Ministry of MSME)

B-36, CHANDKA INDUSTRIAL AREA, BHUBANESWAR - 751 024, ODISHA

Phone : Direct (0674) 3011710 (Purchase)

Fax : 91-674-2743061, Email : cttc@cttc.gov.in, Website : www.cttcbbbsr.co.in

ISO-9001, ISO-14001
OHSAS-18001
ISO-29990

M/s Gram Tarang Employability Training Services Private Limited
J.I.T.M Campus, Aluri Nagar, R.Sitapur
Paralakhemundi - 761211
Ph No: +91 891 6587657, 09437619974

Purchase/Work Order No.: - 1703074
Date :- 07.08.2017
Our Tender Enquiry No.: - As per N.S. Approval
Date :- 06.12.2017
Your Ref. No.: - Nil
Date :- Nil
Indentor :- KVK

The undersigned is pleased to order the followings/accepts your tender mentioned above for supplies/services as detailed in the schedule below subject to terms and conditions mentioned under and over leaf herewith.

Sl. No.	Articles/Services to be supplied	Quantity	Unit	Unit Price		Amount	
				Rs.	P.	Rs.	P.
1	Machining of components as per enclosed annexure-I Material shall be supplied by CTTC BBSR. Other terms & condition as per enclosed Annex-II & attached Checklist for the supplier. Criteria of Acceptance: Approval of Sample & CTTC Inspection Report. OUR GST No: 21AAABC0056G1ZI As per GST rule two copies of invoice is to be furnished for release of payment.						578990.00

Total in Words (Rupees Five Lakh Seventy Eight Thousand Nine Hundred Ninety Only)

578990.00

TERMS & CONDITIONS

- Sales Tax : GST: As mentioned in annexure (GST to be shown separately)
- Excise Duty : nil
- Octroi Duty : nil
- Any other Taxes / Duties if any : nil
- Insurance : nil
- Packing / Forwarding : nil
- Mode of Transport and Charges : nil
- Delivery Schedule : nil
- Terms of Payment : Delivery - Within 30 Days of receipt of material.
Payment - Within 30 days of delivery and acceptance of items.

Date -

Managing Director/
Authorised Official



HINDUSTAN AERONAUTICS LIMITED
ENGINE DIVISION, KORAPUT
PO: SUNABEDA, DIST: KORAPUT
ODISHA - 763002
INDIA

PHONE : 06853-221908
 FAX : 06853-22004
 E-MAIL : subcontract-ed.korapat@h

M/s.
GRAM TARANG EMPLOYABILITY TRAINING SERVICES PVT
 CUTM- CIT CAMPUS
 RAMACHANDRAPUR, JATNI, DISTT. KHURDA
 BHUBANESWAR 752 050
 INDIA
 Fax : 0674-2352 433 Phone : 0674-2352 667
 Email : shashikant.fewary@gramtarang.in

P.O Number : **HBK/ 14G4I-1069 - 99**
 P.O DATE : **07/01/2015**
 Proj. Code : Bgt. Code :
 Sup. Code :
 Budget Ref :

YOUR OFFER REF.: Eng No.HBK/14GU-1076/1-99 dt. 11/10/2014, Offer ref: GTET/HBK/14GU-1076/1-99 Dated 06/11/2014
 RTGS/CORE REF : 04951131001588

Sirs,
 Please supply the following material(s) in accordance with the terms and conditions of contract enclosed.

SI No	Part No/Nomenclature	Qty/ UnitDes	Unit Rate In INR	Item Dis In %	Unit Rate After Disc.	Total In INR
Subcontract Items As Per Enclosure, 6 Item(s)						
TOTAL						144817.43
NET VALUE						INR 144,817.43

Rupees :One lakh Forty-Four Thousand Eight Hundred Seventeen and Forty-Three Paise Only

PRICES : FOR HAL SUNABEDA (P & F Charges nil)
 TAXES : Ref point no 29 of this purchase order
 PAYMENT : 100% payment by RTGS/ NEFT/ CORE BANKING against proof of receipt and acceptance of the finished components/items at our works, not later than 45 days from the date of receipt of material at HAL. Bank charges to your account.

DELIVERY : Sample part of qty. 10 (maximum) with in 26 weeks from the date of receipt of raw material at your end/last written technical input, whichever is later. Productionized parts within 24 weeks from the date of receipt of raw material at your end/date of acceptance of sample part by HAL Quality Department/as per HAL written production plan/last written technical input, whichever is later. The date of receipt of raw-material at your end will be taken 2 weeks from the date of despatch from our works. Staggered delivery are allowed.

DESPATCH INSTRUCTION : Refer Point No 33 of this Purchase Order

INSURANCE : To your account.

FINAL INSPECTION & ACCEPTANCE : At our works for quality / test by our Inspector Furnish Test Certificate wherever applicable.
 [NOTE : NO PAYMENT EITHER DIRECT OR THROUGH BANK WILL BE MADE UNLESS TWO COPIES INVOICE RECEIVED BY THE SR. MANAGER(OUTSOURCING) IN ADVANCE]

Yours faithfully
 For HINDUSTAN AERONAUTICS LIMITED,
 ENGINE DIVISION - KORAPUT

DY. GENERAL MANAGER (OUTSOURCING)

जी.के. उपाध्याय/G.K.Upadhyay
 स.स. महाप्रबंधक (बाह्य स्रोत)
 Dy. General Manager (OS)



HINDUSTAN AERONAUTICS LIMITED

FORMAT NO : 551014

ENGINE DIVISION - KORAPUT
PO: SUNABEDA, DIST: KORAPUT
ODISHA - 763002
INDIA

PHONE : 06853-221908
FAX : 06853-22004
E-MAIL : subcontract-ed.koraput@hal-india.com

PURCHASE ORDER - OUTSOURCING

M/s. **GRAM TARANG EMPLOYABILITY TRAINING SERVICES PVT**
CUTM - CIT CAMPUS
RAMACHANDRAPUR, JATNI, DISTT.KHURDA
INDIA
BHUBANESWAR 752 050
INDIA
Fax : 0674-2352 433 Phone : 0674-2352 667
Email : shashkant.tewary@gramtarang.in

P.O Number : **HBK/ 14K4I-1062 - 99**
P.O DATE : **28/01/2015**

Proj. Code :
Sup. Code :
Budget Ref :

YOUR OFFER REF : Enq No.HBK/14KU-1063/1-99 dt: 23/11/2014; Offer ref: GTET/HBK/14KU-1063/1 Dated 01/01/2015
RTGS/CORE REF : 04951131001588

Dear Vendor/Supplier,
In accordance with terms and conditions of above cited tender enquiry we are pleased to place this purchase order on you.
Kindly Supply the following material(s) in strict compliance to terms and conditions herein.

Sl No	Part No/Nomenclature	Qty/ UnitDes	Unit Rate In INR	Item Dis In %	Unit Rate After Disc.	Total In INR
Subcontract Items As Per Enclosure, 9 Item(s)						
TOTAL						47708.30
NET VALUE						INR 47,708.30

Rupees :Forty-Seven Thousand Seven Hundred Eight and Thirty Paise Only

PRICES : FOR HAL SUNABEDA (including P & F Charges)

TAXES : Ref point no 29 of this purchase order

PAYMENT : 100% payment by RTGS/ NEFT/ CORE BANKING against proof of receipt and acceptance of the finished components/items at our works, not later than 45 days from the date of receipt of material at HAL. Bank charges to your account.

DELIVERY : Sample part of qty:10 (maximum) with in 26 weeks from the date of receipt of raw material at your end/last written technical input, whichever is later.Productionized Parts within 24 weeks from the date of receipt of raw material at your end/date of acceptance of sample part by HAL Quality Department/as per HAL written production plan/last written technical input, whichever is later.The date of receipt of raw-material at your end will be taken 2 weeks from the date of despatch from our works.Staggered delivery are allowed.

DESPATCH INSTRUCTION : Refer Point No. 33 of this Purchase Order.

INSURANCE : To your account.

SPECIAL INSTRUCTIONS: Final acceptance of Supplied parts / Materials shall be done at our works.

1. It is mandatory for the Vendor to submit the Inspection record sheet along with Supplied part(s) / Material(s).

2. No payment against this PO shall be processed by HAL unless 02 copies of Invoice are received in advance by Sr.Manager (Outsourcing

Yours faithfully
For HINDUSTAN AERONAUTICS LIMITED,
ENGINE DIVISION - KORAPUT

जी. के. उपाध्याय/G.K.Upadhyay
उप महाप्रबंधक (बाह्य खोल)
Dy. General Manager(OS)

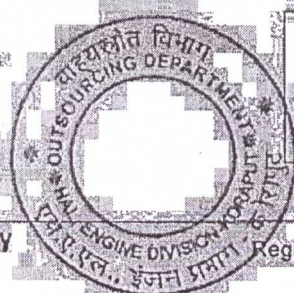

**Please expedite
Acceptance of the Order
at the earliest**

Registered Office : 15/1, Cubbon Road, Bangalore-56000



HINDUSTAN AERONAUTICS LIMITED
ENGINE DIVISION, KORAPUT
PO: SUNABEDA, DIST: KORAPUT
ODISHA - 763002
INDIA

PHONE : 06853-221908

FAX : 06853-22004

E-MAIL : subcontract-ed.koraput@hal.com

M/s.
GRAM TARANG EMPLOYABILITY TRAINING SERVICES PVT
CUTM-CIT CAMPUS
RAMACHANDRAPUR, JATNI, DISTT.KHURDA
BHUBANESWAR 752 050
INDIA
Fax : 0674-2352 433 Phone: 0674-2352 667
Email : shashikant.tewary@gramtarang.in

P.O Number : HBK/ 14G4I-1056 - 99
P.O DATE : 20/01/2015

Proj. Code : Bgt. Code:
Sup. Code :
Budget Ref :

YOUR OFFER REF : Eng No.HBK/14GU-1061/1-99 dt. 06/08/2014, Offer ref: GTET/HBK/14GU-1061/1 Dated 04/09/2014
RTGS/CORE REF :- 04951131001588

Sirs,
 Please supply the following material(s) in accordance with the terms and conditions of contract enclosed

SI No	Part No/Nomenclature	Qty/ UnitDes	Unit Rate In INR	Item Dis In %	Unit Rate After Disc.	Total In INR
-------	----------------------	-----------------	---------------------	------------------	--------------------------	-----------------

Subcontract Items

As Per Enclosure, 5 Item(s)

TOTAL 53630.37
NET VALUE INR 53,630.37

Rupees :Fifty-Three Thousand Six Hundred Thirty and Thirty-Seven Paise Only

PRICES : FOR HAL SUNABEDA (including P & F Chrages)

TAXES : Ref point no 29 of this purchase order

PAYMENT : 100% payment by RTGS/ NEFT/ CORE BANKING against proof of receipt and acceptance of the finished components/items at our works, not later than 45 days from the date of receipt of material at HAL. Bank charges to your account.

DELIVERY : Sample part of qty: 5 (maximum) with in 10 weeks from the date of receipt of raw material at your end/last written technical input, whichever is later. Bulk part within 20 weeks from the date of receipt of raw material at your end/date of acceptance of sample part by HAL Quality Department/as per HAL written production plan/last written technical input, whichever is later. The date of receipt of raw-material at your end will be taken 2 weeks from the date of despatch from our works. Staggered delivery are allowed.

DESPATCH INSTRUCTION : Refer Point No. 33 of this Purchase Order

INSURANCE : To your account.

FINAL INSPECTION & ACCEPTANCE : At our works for quality / test by our Inspector Furnish Test Certificate wherever applicable.
[NOTE : NO PAYMENT EITHER DIRECT OR THROUGH BANK WILL BE MADE UNLESS TWO COPIES INVOICE RECIEVED BY THE SR. MANAGER(OUTSOURCING) IN ADVANCE]

Yours faithfully
 For HINDUSTAN AERONAUTICS LIMITED,
 ENGINE DIVISION - KORAPUT

DY. GENERAL MANAGER (OUTSOURCING)

Registered Office : 15/1, Cubbon Road, Bangalore-56000



PURCHASE ORDER

Ref No: CO/MKTG/E-CART/18/3/01

To : M/S. GRAM TARANG EMP. TRAINING SERVICES (P) PLOT NO. 17, FOREST PARK, BHUBANESWAR-9	P.O. No. :	AD196
	Date :	12/07/2018
	Your Ref :	TENDER
	Ref Dt. :	
GST No. :		27AABT10220G2Z2

Please supply the following item(s) subject to General Terms & condition attached / printed overleaf in all Correspondence, challans, Invoices etc. Please quote our order No. to avoid delay in settlement of bills. PLEASE SUBMIT THE BILL IN TRIPLICATE WITH DELIVERY CHALLAN.

SL. NO.	MATERIAL DESCRIPTION	QTY.	UNIT	RATE	TOTAL AMOUNT
---------	----------------------	------	------	------	--------------

1	E-CART BATTERY OPERATED E-CART SPECIFICATION AS PER TENDER DOCUMENT. REGISTRATION OF VEHICLE AT LOCAL RTO, BBSR. CUSTOMIZATION & BRANDING AS PER OMFED SPECIFICATION.	40.000	NOS	150000.00	6000000.00
---	---	--------	-----	-----------	------------

6000000.00

Add : GOODS & SERVICES TAX-EXTRA	12.00%	720000.00
Add : FREIGHT-INCLUSIVE		
Add : INSURANCE CHARGES-INCLUSIVE		
Add : WARRANTY-1 YEAR ON BATTERY SET.		
Add : WARRANTY-2YR ON METAL BODY.		
Add : WARRANTY-2 YR ON MECHANICAL PARTS.		
Add : WARRANTY-1 YR ON DEEP FREEZER & BOTTLE CHIL		
Add : WARRANTY-2 YR ON MUSIC SYSTEM.		
Add : WARRANTY-1 YR ON LIGHTS.		

Rupees Rs. 6720000.00
Sixty seven lac twenty thousand only

Price basis F.O.R BASIS	Consignee : DY.GENERAL MANAGER(MKTG) OMFED, D/2, SAHIDNAGAR, BHUBANESWAR-7	Payment Terms : 90% PAYMENT & 100 % TAXES WITHIN 30 DAYS OF SUCCESSFUL DELIVERY OF THE E-CART & BALANCE 10% AFTER COMPLETION OF 2 YRS.
E.D. Delivery IMMEDIATE	Accepted the order unconditionally	FOR OMFED
Signature and Seal of the Supplier.	 (AUTHORISED SIGNATORY)	
Copies : 1) Dy. Gen. Manager (Finance) 2) Internal Auditor	3) 4)	INCHARGE (MM).



P.T.O.



Terms & Conditions of Purchase Order

1	Acknowledgment	The duplicate copy must be sent duly signed & sealed as a token of acceptance within 7 days from the date of issue through e-mail, fax, speed post or courier. In case of non-acceptance of the order by you, the Security Deposit / EMD will be forfeited and your offer will not be considered in future.
2	Reference	The purchase order no & date to be quoted in all correspondence including despatch document & invoice.
3	Sales Tax & Duties	CST as applicable extra against Form-C. Please do not ask "C" Form through Bank. TIN No. 21881106527. The supplier should take initiation within 03 months from the supply date of materials to collect the C-Form from the authority. Delay in making the request may not fetch C Form to the supplier from the tax authorities.
4	Mode of Despatch	Will be arranged by the supplier/ us by Rail/Road within 10 days of receipt of order on freight paid/ To pay/ To be billed basis.
5	Delivery	As per Schedules as mentioned overleaf. For outside state transaction, the Invoice copy may be sent through e-mail in advance to forward the online waybill through e-mail. In case of part supply proportionate Security Deposit will be forfeited.
6	Billing	Bills should be raised in triplicate in favour of the OMFED
7	Claims of Carrier/	Unless otherwise specified transit insurance shall be arranged by the supplier
8	Inspection	All materials after being received at site will be inspected by inspector (s) nominated by OMFED. Material supplied if found defective, substandard, not up to the specification or otherwise unsuitable will be rejected & will be sent back to the supplier at his cost. The supplier shall replace the material so rejected within 15 days from the receipt of such rejected material. Weighment recorded at our plant is final.
9	Pre-despatch inspection	The undersigned reserves the right to inspect the material prior to despatch from the Supplier's Godown.
10	Variation of quantity	The undersigned reserves the right to increase or decrease the quantities mentioned in the purchase order without any notice. Allowed quantity variation +/- 10% of the Order.
11	Cancellation	The undersigned reserves the right to cancel the order at any time without assigning any reason.
12	Earnest Money	Earnest Money if any is liable to be forfeited if the supplier fails supply material in time or in accordance with the terms of the purchase order / Tender.
13	Security Deposit	EMD will be adjusted towards security deposit as per rules of Federation/Tender terms.
14	Legal Jurisdiction	Legal dispute if any arising out of this purchase, shall be subjected to such courts exercising civil jurisdiction over Bhubaneswar
15	Penalty	Delivery period is the essence of contract and the material should be despatched in time. In case of failure to supply in time 1/2% value of delayed delivered quantity for week will be deducted.
16	Guarantee	Equipments supplied against this order must be guaranteed for a period as mentioned overleaf for any manufacturing defects.
17	Issue of Sales Tax Declaration from	Will be issued only after request from the seller with copies of bills once in a quarter covering all the bills during the quarter.



Gram Tarang Employability Training Services PVT.LTD

Corporate Office: 17 | Forest Park | Bhubaneswar | Odisha 751009

Workshop Address: CUTM Campus | Ramachandrapur | Jatni | Khordha | Odisha | 752050

Phone : +91-674-2596228 | 9861754207 |

E-mail: info@gramtarang.in

GSTIN - 21AABCC9406C1ZB

An ISO 9001 : 2008 Certified Company

TRIPLICATE FOR SUPPLIER

TAX INVOICE

BILLING TO	
OMFED, D-2, SAHID NAGAR, BHUBANESWAR, KHORDA, ODISHA - 751007 GST NO : 21AABTT3220G2Z2	

INVOICE NO..	DATE :
801 801	04/01/2019
ORDER NO..	DATE :

SL. NO.	PRODUCT DESCRIPTION	HSN CODE	UOM	QTY	UNIT PRICE	AMOUNT
01	E-CART (TAURUS)	8703	PCS	10	91,911.00	9,19,110.00
	Music System, Wind shield, Charger					
	Chassis Number - M7VGECLBKDH000071					
	M7VGECLBKDH000072, M7VGECLBKDH000076,					
	M7VGECLBKDH000077, M7VGECLBKDH000080,					
	M7VGECLBKDH000086, M7VGECLBKDH000087,					
	M7VGECLBKDH000088, M7VGECLBKDH000089,					
	M7VGECLBKDH000090					
02	GFR 250ET	84183090	NOS	10	26,700.00	2,67,000.00
	Deep freezer 250 ltr (Rockwell)					
03	IC 432ET	84185000	NOS	10	22,300.00	2,23,000.00
	Bottle chiller 260 ltr (Rockwell)					
SUB-TOTAL						14,09,110.00
CGST 6 %						84,546.60
SGST 6 %						84,546.60
IGST %						
TOTAL						15,78,203.20
03	Insurance & Registration			10 units	10,180.00	1,01,800.00
	Others					
IN WORDS :						G . TOTAL
SIXTEEN LAKH EIGHTY THOUSAND ONLY						ROUND OFF
						16,80,003.20
						16,80,000.00

TERMS & CONDITIONS :

- Goods once sold can not be return back.
- All matters subject to Bhubaneswar jurisdiction.

BANK DETAILS :

NAME : GRAM TARANG EMPLOYABILITY TRAINING SERVICES PVT.LTD.
A/C NUMBER : 14261131000892
IFSC CODE : ORBC0101426
A/C TYPE : CURRENT

RECEIVER'S SIGNATRE :

AUTHORISED SIGNATORY :



The Orissa State Co-operative Milk Producers Federation Ltd.,
D-2, Sahid Nagar, Bhubaneswar-7



Gram Tarang Employability Training Services PVT.LTD

Corporate Office: 17 | Forest Park | Bhubaneswar | Odisha 751009

Workshop Address: CUTM Campus | Ramachandrapur | Jatni | Khordha | Odisha | 752050

Phone : +91-674-2596228 | 9861754207 |

E-mail: info@gramtarang.in

An ISO 9001 : 2008 Certified Company

GSTIN - 21AABCC9406C1ZB

ORIGINAL FOR RECIPIENT

TAX INVOICE

BILLING TO

OMFED,
D-2, SAHID NAGAR, BHUBANESWAR,
KHORDA, ODISHA - 751007
GST NO : 21AABTT3220G222

INVOICE NO..	DATE :
803	10/01/2019

ORDER NO..	DATE :

SL. NO.	PRODUCT DESCRIPTION	HSN CODE	UOM	QTY	UNIT PRICE	AMOUNT
01	E-CART (TAURUS)	8703	PCS	10	91,911.00	9,19,110.00
	Music System, Wind shield, Charger					
	Chassis Number - M7VGECLBHDH000051					
	M7VGECLBHDH000052,M7VGECLBHDH000053,					
	M7VGECLBHDH000054,M7VGECLBHDH000055,					
	M7VGECLBHDH000056,M7VGECLBHDH000057,					
	M7VGECLBHDH000058,M7VGECLBHDH000059,					
	M7VGECLBHDH000060					
02	GFR 250ET	84183090	NOS	10	26,700.00	2,67,000.00
	Deep freezer 250 ltr (Rockwell)					
03	IC 432ET	84185000	NOS	10	22,300.00	2,23,000.00
	Bottle chiller 260 ltr (Rockwell)					
SUB-TOTAL						14,09,110.00
CGST 6 %						84,546.60
SGST 6 %						84,546.60
IGST %						
TOTAL						15,78,203.20
03	Insurance & Registration		10 units		10,180.00	1,01,800.00
	Others					
IN WORDS :				G . TOTAL		16,80,003.20
SIXTEEN LAKH EIGHTY THOUSAND ONLY				ROUND OFF		16,80,000.00

TERMS & CONDITIONS :

- Goods once sold can not be return back.
- All matters subject to Bhubaneswar jurisdiction.

BANK DETAILS :

NAME : GRAM TARANG EMPLOYABILITY TRAINING SERVICES PVT.LTD.
A/C NUMBER : 14261131000892
IFSC CODE : ORBC0101426
A/C TYPE : CURRENT

RECEIVER'S SIGNATRE :

AUTHORISED SIGNATORY





Gram Tarang Employability Training Services PVT.LTD

Corporate Office: 17 | Forest Park | Bhubaneswar | Odisha 751009

Workshop Address: CUTM Campus | Ramachandrapur | Jatni | Khordha | Odisha | 752050

Phone : +91-674-2596228 | 9861754207 |

E-mail: info@gramtarang.in

GSTIN - 21AABCC9406C1ZB

An ISO 9001 : 2008 Certified Company

ORIGINAL FOR RECIPIENT

TAX INVOICE

BILLING TO

OMFED,
D-2, SAHID NAGAR, BHUBANESWAR,
KHORDA, ODISHA - 751007
GST NO : 21AABTT3220G2Z2

INVOICE NO..	DATE :
805	15/01/2019
ORDER NO..	DATE :

SL. NO.	PRODUCT DESCRIPTION	HSN CODE	UOM	QTY	UNIT PRICE	AMOUNT
01	E-CART (TAURUS)	8703	PCS	10	91,911.00	9,19,110.00
	Music System, Wind shield, Charger					
	Chassis Number - M7VGECLBHDH000061					
	M7VGECLBJDH000062, M7VGECLBJDH000063,					
	M7VGECLBJDH000064, M7VGECLBJDH000065,					
	M7VGECLBJDH000066, M7VGECLBJDH000067,					
	M7VGECLBJDH000068, M7VGECLBJDH000069,					
	M7VGECLBJDH000070					
02	GFR 250ET	84183090	NOS	10	26,700.00	2,67,000.00
	Deep freezer 250 ltr (Rockwell)					
03	IC 432ET	84185000	NOS	10	22,300.00	2,23,000.00
	Bottle chiller 260 ltr (Rockwell)					
SUB-TOTAL						14,09,110.00
CGST 6 %						84,546.60
SGST 6 %						84,546.60
IGST %						
TOTAL						15,78,203.20
03	Insurance & Registration			10 units	10,180.00	1,01,800.00
	Others					
G . TOTAL						16,80,003.20
ROUND OFF						16,80,000.00
IN WORDS :						
SIXTEEN LAKH EIGHTY THOUSAND ONLY						

TERMS & CONDITIONS :

- Goods once sold can not be return back.
- All matters subject to Bhubaneswar jurisdiction.

BANK DETAILS :

NAME : GRAM TARANG EMPLOYABILITY TRAINING SERVICES PVT.LTD.

A/C NUMBER : 14261131000892

IFSC CODE : ORBC0101426

A/C TYPE : CURRENT

RECEIVER'S SIGNATRE :

AUTHORISED SIGNATORY :





Gram Tarang Employability Training Services PVT.LTD

Corporate Office: 17 | Forest Park | Bhubaneswar | Odisha 751009

Workshop Address: CUTM Campus | Ramachandrapur | Jatni | Khordha | Odisha | 752050

Phone : +91-674-2596228 | 9861754207 |

E-mail: info@gramtarang.in

GSTIN - 21AABCC9406G1ZB

An ISO 9001 : 2008 Certified Company

ORIGINAL FOR RECIPIENT

TAX INVOICE

BILLING TO

OMFED,
D-2, SAHID NAGAR, BHUBANESWAR,
KHORDA, ODISHA - 751007
GST NO : 21AABTT3220G2Z2

INVOICE NO..	DATE :
811	16/01/2019

ORDER NO..	DATE :

SL. NO.	PRODUCT DESCRIPTION	HSN CODE	UOM	QTY	UNIT PRICE	AMOUNT
01	E-CART (TAURUS)	8703	PCS	10	91,911.00	9,19,110.00
	Music System, Wind shield, Charger					
	Chassis Number - M7VGECLBKDH000073					
	M7VGECLBKDH000074, M7VGECLBKDH000075,					
	M7VGECLBKDH000078, M7VGECLBKDH000079,					
	M7VGECLBKDH000081, M7VGECLBKDH000082,					
	M7VGECLBKDH000083, M7VGECLBKDH000084,					
	M7VGECLBKDH000085					
02	GFR 250ET	84183090	NOS	10	26,700.00	2,67,000.00
	Deep freezer 250 ltr (Rockwell)					
03	IC 432ET	84185000	NOS	10	22,300.00	2,23,000.00
	Bottle chiller 260 ltr (Rockwell)					
SUB-TOTAL						14,09,110.00
CGST 6 %						84,546.60
SGST 6 %						84,546.60
IGST %						
TOTAL						15,78,203.20
03	Insurance & Registration		10 units		10,180.00	1,01,800.00
	Others					
IN WORDS :				G . TOTAL		16,80,003.20
SIXTEEN LAKH EIGHTY THOUSAND ONLY				ROUND OFF		16,80,000.00

TERMS & CONDITIONS :

- Goods once sold can not be return back.
- All matters subject to Bhubaneswar jurisdiction.

BANK DETAILS :

NAME : GRAM TARANG EMPLOYABILITY TRAINING SERVICES PVT.LTD.
A/C NUMBER : 14261131000892
IFSC CODE : ORBC0101426
A/C TYPE : CURRENT

RECEIVER'S SIGNATRE :

AUTHORISED SIGNATORY





Account Statement for Account Number 14261131000892

Acc. Statement Date: 07/02/2019 1.20 PM

Branch Details

Branch Name :ARAGUL-JATANI

Bank Address : ORIENTAL BANK OF COMMERCE

B/O ARAGUL RAMCHANDRAP

UR,MAA DAMUNEI MANDIR

City :ARAGUL

Pin :752050

IFSC Code:ORBC0101426

Customer DetailsCustomer Name :GRAM TARANG
EMPLOYABILITY TRAINING SERVICES PVT.
LTD.Joint Holder Name :BINAYA KUMAR
BOSE,MUKTI KANTA MISHRACustomer Address :HIG-5, PHASE-1, BDA
DUPLEX, POKHARIPUT,

BHUBANESWAR

City :BHUBANESHWAR

Pin :751001

Nominee :

Customer ID :25077640

Statement Period:From Date:01/04/2017 To Date:31/03/2018

Sl. No.	Transaction Date	Value Date	Instrument ID	Narration	Debit	Credit	Account Balance	Remarks
1	31/03/2018	31/03/2018		Loan Recovery For 14266515002745	9,880.16		94,949.99	Loan Recovery
2	29/03/2018	29/03/2018		By Inst.160045/AXISBANK/		12,000.00	1,04,830.15	
3	29/03/2018	29/03/2018	22282	ASPER LIST	2,18,850.00		92,830.15	
4	29/03/2018	29/03/2018	22283	SELF	30,000.00		3,11,680.15	
5	28/03/2018	28/03/2018		NEFT-CARE INSTITUTE OF HEALTH		28,800.00	3,41,680.15	NEFT- KKBKH18087840 151
6	28/03/2018	28/03/2018		NEFT-HANON CLIMATE SYSTEMS IND		40,841.81	3,12,880.15	NEFT- 27032018016882
7	28/03/2018	28/03/2018	22281	ASPER LIST	1,28,000.00		2,72,038.34	
8	28/03/2018	28/03/2018		04951131001588		3,00,000.00	4,00,038.34	
9	27/03/2018	27/03/2018	22280	ASPER LIST	10,500.00		1,00,038.34	
10	27/03/2018	27/03/2018		NEFT-NETTUR TECHNICAL TRAINING		6,000.00	1,10,538.34	NEFT- SBIN9180861744 25
11	26/03/2018	26/03/2018		NEFT-BEST FIRST STEP EDUCATION		6,000.00	1,04,538.34	NEFT- AXSK180850003 388
12	23/03/2018	23/03/2018	22279	ASPER LIST	10,951.00		98,538.34	
13	23/03/2018	23/03/2018		VISHA-CASH DEPOSIT		3,500.00	1,09,489.34	
14	22/03/2018	22/03/2018	22277	ASPER LIST	1,57,000.00		1,05,989.34	

Account Statement for Account Number 14261131000892

15	21/03/2018	21/03/2018		Charges for NEFT Customer Payment :SAA54252213	29.00		2,62,989.34	
16	21/03/2018	21/03/2018	022276	NEFT-OW/SAA54252213/GRAM TARANG EMPLOYABILITY	6,00,000.00		2,63,018.34	
17	21/03/2018	21/03/2018		04951131001588		5,50,000.00	8,63,018.34	
18	20/03/2018	20/03/2018		Charges for NEFT Customer Payment :SAA54217269	29.00		3,13,018.34	
19	20/03/2018	20/03/2018	022274	NEFT-OW/SAA54217269/GRAM TARANG EMPLOYABILITY	12,00,000.00		3,13,047.34	
20	20/03/2018	20/03/2018		04951131001588		14,00,000.00	15,13,047.34	
21	20/03/2018	20/03/2018	22275	ASPER LIST	3,06,500.00		1,13,047.34	
22	20/03/2018	20/03/2018		NEFT-GRAM TARANG-AS-DDU-G		9,000.00	4,19,547.34	NEFT-P18032056586466
23	20/03/2018	20/03/2018		NEFT-GRAM TARANG-AS-DDU-G		6,000.00	4,10,547.34	NEFT-P18032056586456
24	20/03/2018	20/03/2018		SGST ON CASH HANDLING CHRGS	3.00		4,04,547.34	
25	20/03/2018	20/03/2018		CGST ON CASH HANDLING CHRGS	3.00		4,04,550.34	
26	20/03/2018	20/03/2018		CASH HANDLING CHRGS for 19-03-2018	33.00		4,04,553.34	
27	19/03/2018	19/03/2018		LUDHI-CASH DEPOSIT		1,65,500.00	4,04,586.34	
28	17/03/2018	17/03/2018		Chrgs for RTGS Cust Pymnt:ORBCH18076097467	60.00		2,39,086.34	RTGS
29	17/03/2018	17/03/2018	022273	RTGS-OW/ORBCH18076097467/G RAM TARANG EMPLOYABILITY	7,00,000.00		2,39,146.34	RTGS
30	17/03/2018	17/03/2018	22272	AS PER LIST	1,02,093.00		9,39,146.34	
31	16/03/2018	16/03/2018		BY 04951131001588		2,00,000.00	10,41,239.34	
32	16/03/2018	16/03/2018		Charges for NEFT Customer Payment :SAA54068950	12.00		8,41,239.34	NEFT
33	16/03/2018	16/03/2018	022271	NEFT-OW/SAA54068950/BINAY KUMAR SINGH	7,000.00		8,41,251.34	NEFT
34	16/03/2018	16/03/2018	22268	CENTURION SCIENCE AND TECHNOLOGY ENTERPRENEUSHIP F	25,587.00		8,48,251.34	
35	16/03/2018	16/03/2018	22267	TRF TO 04951131001953	2,10,000.00		8,73,838.34	
36	16/03/2018	16/03/2018	22269	TRF TO 14261131001448	2,02,017.00		10,83,838.34	
37	16/03/2018	16/03/2018	22270	TRF TO 04951131001953	50,392.00		12,85,855.34	
38	16/03/2018	16/03/2018		RTGSCENTURION UNIVERSITY OF TE		10,82,237.00	13,36,247.34	RTGSUTIBR52018031600355075
39	16/03/2018	16/03/2018		By Inst.94319/CITIBANK/		21,486.00	2,54,010.34	
40	16/03/2018	16/03/2018		By Inst.192042/CANARA/		52,500.00	2,32,524.34	
41	16/03/2018	16/03/2018		By Inst.72/HDFCBANK/		46,502.00	1,80,024.34	

Account Statement for Account Number 14261131000892

42	15/03/2018	15/03/2018		Chrgs for RTGS Cust Pymnt:ORBCH18074004324	60.00		1,33,522.34	RTGS
43	15/03/2018	15/03/2018	022265	RTGS- OW/ORBCH18074004324/G RAM TARANG EMPLOYABILITY	8,00,000.00		1,33,582.34	RTGS
44	14/03/2018	14/03/2018		TRF FROM 04951131001588		4,80,000.00	9,33,582.34	
45	12/03/2018	12/03/2018	22264	ASPER LIST	28,722.00		4,53,582.34	
46	12/03/2018	12/03/2018		04951131001588		2,00,000.00	4,82,304.34	
47	09/03/2018	09/03/2018	22263	ASPER LIST	6,421.00		2,82,304.34	
48	08/03/2018	08/03/2018	22262	AS PER LIST	76,000.00		2,88,725.34	
49	08/03/2018	08/03/2018		NEFT-CENTURI		1,85,986.00	3,64,725.34	NEFT- AXTB180676618 902
50	07/03/2018	07/03/2018	22261	ASPER LIST	4,67,000.00		1,78,739.34	
51	06/03/2018	06/03/2018	22260	ASPER LIST	1,06,626.00		6,45,739.34	
52	06/03/2018	06/03/2018	22257	AP TRADING	75,375.00		7,52,365.34	Zone Serial [80]
53	05/03/2018	05/03/2018	22259	ASPER LIST	2,75,854.00		8,27,740.34	
54	05/03/2018	05/03/2018		04951131001588		2,00,000.00	11,03,594.34	
55	05/03/2018	05/03/2018		NEFT-POTENTIAL HUMAN RESOURCES		19,295.00	9,03,594.34	NEFT- 20448756451DC
56	02/03/2018	02/03/2018	22255	LCCCMS POOL ACNONUTI	17,690.00		8,84,299.34	Zone Serial [34]
57	01/03/2018	01/03/2018		Charges for NEFT Customer Payment :SAA53522631	29.00		9,01,989.34	
58	01/03/2018	01/03/2018	022258	NEFT- OW/SAA53522631/GRAM TARANG EMPLOYABILITY	20,00,000.00		9,02,018.34	
59	01/03/2018	01/03/2018	22256	ASPER LIST	1,37,159.00		29,02,018.34	
60	01/03/2018	01/03/2018		04951131001588		20,00,000.00	30,39,177.34	
61	01/03/2018	01/03/2018		RTGSFEEDBACK ENERGY DISTRIBUTI		3,77,372.00	10,39,177.34	RTGSSBINR1201 8030100013427
62	01/03/2018	01/03/2018		SGST ON CASH HANDLING CHRGs	1.00		6,61,805.34	
63	01/03/2018	01/03/2018		CGST ON CASH HANDLING CHRGs	1.00		6,61,806.34	
64	01/03/2018	01/03/2018		CASH HANDLING CHRGs for 28-02-2018	6.00		6,61,807.34	
65	28/02/2018	28/02/2018		Loan Recovery For 14266515002745	9,880.27		6,61,813.34	Loan Recovery
66	28/02/2018	28/02/2018		NEFT-HANON CLIMATE SYSTEMS IND		56,247.37	6,71,693.61	NEFT- BD180228605048 93
67	28/02/2018	28/02/2018		CASH DEPOSIT		1,50,000.00	6,15,446.24	
68	27/02/2018	27/02/2018		04951131001588		3,00,000.00	4,65,446.24	
69	26/02/2018	26/02/2018	022254	NEFT- OW/SAA53366086/CESU KED KHURDA	678.00		1,65,446.24	

F Account Statement for Account Number 14261131000892

70	26/02/2018	26/02/2018		Charges for NEFT Customer Payment :SAA53365297	12.00		1,66,124.24	
71	26/02/2018	26/02/2018	022253	NEFT-OW/SAA53365297/CESU KED KHURDA	4,104.00		1,66,136.24	
72	23/02/2018	23/02/2018	22252	ASPER LIST	1,52,000.00		1,70,240.24	
73	22/02/2018	22/02/2018	22251	ASPER LIST	1,05,190.00		3,22,240.24	
74	21/02/2018	21/02/2018		Charges for NEFT Customer Payment :SAA53223677	29.00		4,27,430.24	
75	21/02/2018	21/02/2018	019250	NEFT-OW/SAA53223677/GRAM TARANG EMPLOYABILITY	17,00,000.00		4,27,459.24	
76	21/02/2018	21/02/2018		04951131001588		17,00,000.00	21,27,459.24	
77	21/02/2018	21/02/2018		By Inst.67/HDFCBANK/		37,502.00	4,27,459.24	
78	20/02/2018	20/02/2018	19249	ASPER LIST	2,17,353.00		3,89,957.24	
79	19/02/2018	19/02/2018		04951131001588		3,50,000.00	6,07,310.24	
80	16/02/2018	16/02/2018	19248	ASPER LIST	3,80,995.00		2,57,310.24	
81	16/02/2018	16/02/2018		NEFT-HANON CLIMATE SYSTEMS IND		57,037.12	6,38,305.24	NEFT-BD18021659966120
82	16/02/2018	16/02/2018		By Inst.11408/HDFCBANK/		1,11,156.00	5,81,268.12	
83	16/02/2018	16/02/2018		By Inst.3534/UNION/		11,450.00	4,70,112.12	
84	15/02/2018	15/02/2018		14265015002678		1,30,000.00	4,58,662.12	
85	15/02/2018	15/02/2018		COIMB-K G CENTURION		41,500.00	3,28,662.12	
86	15/02/2018	15/02/2018		COIMB-K G CENTURION		27,500.00	2,87,162.12	
87	13/02/2018	13/02/2018		NEFT-BHAWANI PRASAD DWIVEDI SO		66,400.00	2,59,662.12	NEFT-BARBQ18044593308
88	12/02/2018	12/02/2018	19247	ASPER LIST	5,65,773.00		1,93,262.12	
89	09/02/2018	09/02/2018	19246	ASPER LIST	2,03,590.00		7,59,035.12	
90	09/02/2018	09/02/2018		NEFT-POTENTIAL HUMAN RESOURCES		19,030.00	9,62,625.12	NEFT-20423741331DC
91	09/02/2018	09/02/2018		RANGA-CASH DEPOSIT	BILL NO 8	41,000.00	9,43,595.12	PROJECT
92	08/02/2018	08/02/2018		NEFT-GYAN GURU CONSULTANCY		50,000.00	9,02,595.12	NEFT-20422843611DC
93	08/02/2018	08/02/2018		LUDHI-By Inst.315/ICICIBANK/		4,13,575.00	8,52,595.12	
94	07/02/2018	07/02/2018		NEFT-GRAM TARANG EMPLOYABILITY		13,275.00	4,39,020.12	NEFT-IBKL180207014463
95	07/02/2018	07/02/2018		SGST ON CASH HANDLING CHRGS	1.00		4,25,745.12	
96	07/02/2018	07/02/2018		CGST ON CASH HANDLING CHRGS	1.00		4,25,746.12	
97	07/02/2018	07/02/2018		CASH HANDLING CHRGS for 06-02-2018	10.00		4,25,747.12	
98	06/02/2018	06/02/2018		Chrgs for RTGS Cust Pymnt:ORBCH18037040510	60.00		4,25,757.12	

Account Statement for Account Number 14261131000892

99	06/02/2018	06/02/2018	019245	RTGS- OW/ORBCH18037040510/G RAM TARANG EMPLOYABILITY	10,00,000.00		4,25,817.12	
100	06/02/2018	06/02/2018		CASH DEPOSIT		1,50,000.00	14,25,817.12	
101	06/02/2018	06/02/2018		CASH HANDLING CHRGS for 05-02-2018	1.00		12,75,817.12	
102	05/02/2018	05/02/2018		04951131001588		3,50,000.00	12,75,818.12	
103	05/02/2018	05/02/2018	19244	ASPER LIST	47,310.00		9,25,818.12	
104	05/02/2018	05/02/2018		LUDHI-CASH DEPOSIT		1,01,000.00	9,73,128.12	
105	05/02/2018	05/02/2018		14261131001271		34,188.00	8,72,128.12	
106	05/02/2018	05/02/2018		LUDHI-By Inst.311/ICIBANK/		4,33,441.00	8,37,940.12	
107	05/02/2018	05/02/2018		LUDHI-By Inst.331/ICIBANK/		1,64,552.00	4,04,499.12	
108	03/02/2018	03/02/2018		CHQ ISS CHRGS 17651	472.00		2,39,947.12	
109	03/02/2018	03/02/2018		CHQ ISS CHRGS 15276	472.00		2,40,419.12	
110	03/02/2018	03/02/2018		By Inst.80/HDFCBANK/		75,000.00	2,40,891.12	
111	02/02/2018	02/02/2018		ASSET AUTHOR PVT LTD		960.00	1,65,891.12	
112	02/02/2018	02/02/2018	19243	ASPER LIST	17,714.00		1,64,931.12	
113	02/02/2018	02/02/2018		14261131001677		1,23,827.00	1,82,645.12	
114	02/02/2018	02/02/2018		CHQ ISS CHRGS 17001	472.00		58,818.12	
115	02/02/2018	02/02/2018		CHQ ISS CHRGS 18951	472.00		59,290.12	
116	01/02/2018	01/02/2018	19242	ASPER LIST	19,830.00		59,762.12	
117	31/01/2018	31/01/2018		Loan Recovery For 14266515002745	9,880.76		79,592.12	Loan Recovery
118	30/01/2018	30/01/2018	19241	AS PER LIST	18,738.00		89,472.88	
119	30/01/2018	30/01/2018		COIMB-KG CENTURION		42,500.00	1,08,210.88	
120	29/01/2018	29/01/2018	19240	ASPER LIST	50,369.00		65,710.88	
121	29/01/2018	29/01/2018		CASH DEPOSIT		50,000.00	1,16,079.88	
122	23/01/2018	23/01/2018	19239	AS PER LIST	44,000.00		66,079.88	
123	23/01/2018	23/01/2018		NEFT-POTENTIAL HUMAN RESOURCES		48,000.00	1,10,079.88	NEFT- 20405701461DC
124	20/01/2018	20/01/2018	19238	ASPER LIST	25,000.00		62,079.88	
125	19/01/2018	19/01/2018	19237	ASPER LIST	50,000.00		87,079.88	
126	18/01/2018	18/01/2018		PURNA CHANDRA MAHAKHUDA		7,000.00	1,37,079.88	
127	18/01/2018	18/01/2018	19235	ASPER LIST	1,67,334.00		1,30,079.88	
128	18/01/2018	18/01/2018		By Inst.65/HDFCBANK/		23,307.00	2,97,413.88	
129	17/01/2018	17/01/2018		COIMB-KG CENTURION TRAINING DIVISION OF SRI KANNAP		43,000.00	2,74,106.88	
130	16/01/2018	16/01/2018	19234	ASPER LIST	6,07,870.00		2,31,106.88	
131	16/01/2018	16/01/2018		NEFT-HANON CLIMATE SYSTEMS IND		1,34,635.62	8,38,976.88	NEFT- 16012018016848
132	15/01/2018	15/01/2018		NEFT-OSDA		1,32,300.00	7,04,341.26	NEFT- SBIN3180159563 24
133	15/01/2018	15/01/2018		CASH DEPOSIT		1,00,000.00	5,72,041.26	
134	15/01/2018	15/01/2018		By Inst.64/HDFCBANK/		5,000.00	4,72,041.26	

Account Statement for Account Number 14261131000892

135	15/01/2018	15/01/2018		By Inst.352/STANDARD/		19,400.00	4,67,041.26	
136	15/01/2018	15/01/2018		CHQ ISS CHRGS 22251	472.00		4,47,641.26	
137	15/01/2018	15/01/2018		SGST ON CASH HANDLING CHRGS	5.00		4,48,113.26	
138	15/01/2018	15/01/2018		CGST ON CASH HANDLING CHRGS	5.00		4,48,118.26	
139	15/01/2018	15/01/2018		CASH HANDLING CHRGS for 12-01-2018	52.00		4,48,123.26	
140	12/01/2018	12/01/2018	19233	YOURSELF	2,06,000.00		4,48,175.26	
141	12/01/2018	12/01/2018		LUDHI-CASH DEPOSIT		2,33,500.00	6,54,175.26	
142	11/01/2018	11/01/2018		NEFT-ODISHA SKILL DEVELOPMENT		61,740.00	4,20,675.26	NEFT-SBIN1180117253 54
143	11/01/2018	11/01/2018		NEFT-ODISHA SKILL DEVELOPMENT		30,870.00	3,58,935.26	NEFT-SBIN1180117227 30
144	11/01/2018	11/01/2018		NEFT-ODISHA SKILL DEVELOPMENT		71,221.00	3,28,065.26	NEFT-SBIN1180117207 86
145	11/01/2018	11/01/2018		NEFT-ODISHA SKILL DEVELOPMENT		13,230.00	2,56,844.26	NEFT-SBIN1180117275 54
146	11/01/2018	11/01/2018		NEFT-ODISHA SKILL DEVELOPMENT		43,659.00	2,43,614.26	NEFT-SBIN1180117297 27
147	11/01/2018	11/01/2018		NEFT-ODISHA SKILL DEVELOPMENT		79,380.00	1,99,955.26	NEFT-SBIN1180117323 14
148	11/01/2018	11/01/2018		Charges for NEFT Customer Payment :SAA51820080	29.00		1,20,575.26	
149	11/01/2018	11/01/2018	019232	NEFT-OW/SAA51820080/GRAM TARANG EMPLOYABILITY	5,00,000.00		1,20,604.26	
150	11/01/2018	11/01/2018		SGST TAX	1.00		6,20,604.26	
151	11/01/2018	11/01/2018		CGST TAX	1.00		6,20,605.26	
152	11/01/2018	11/01/2018		SMS CHARGES from 01-10-2017 to 31-12-2017	15.00		6,20,606.26	
153	09/01/2018	09/01/2018	19230	ASPER LIST	1,29,979.00		6,20,621.26	
154	09/01/2018	09/01/2018		Charges for NEFT Customer Payment :SAA51728321	17.00		7,50,600.26	
155	09/01/2018	09/01/2018	019231	NEFT-OW/SAA51728321/SRB AND ASSOCIATES	1,62,000.00		7,50,617.26	
156	09/01/2018	09/01/2018		SGST ON CASH HANDLING CHRGS	3.00		9,12,617.26	
157	09/01/2018	09/01/2018		CGST ON CASH HANDLING CHRGS	3.00		9,12,620.26	
158	09/01/2018	09/01/2018		CASH HANDLING CHRGS for 08-01-2018	36.00		9,12,623.26	
159	08/01/2018	08/01/2018		CASH DEPOSIT		2,00,000.00	9,12,659.26	
160	08/01/2018	08/01/2018		Charges for NEFT Customer Payment :SAA51674011	29.00		7,12,659.26	
161	08/01/2018	08/01/2018	019229	NEFT-OW/SAA51674011/GRAM TARANG EMPLOYABILITY	20,00,000.00		7,12,688.26	

Account Statement for Account Number 14261131000892

162	08/01/2018	08/01/2018	19228	ASPER LIST	2,06,205.00		27,12,688.26	
163	08/01/2018	08/01/2018		By Inst.422144/CITIBANK/		84,016.00	29,18,893.26	
164	08/01/2018	08/01/2018		RTGSOIL INDIA LIMITEDKKBKR2201		25,78,212.01	28,34,877.26	RTGSKKBKR220 18010800024972
165	05/01/2018	05/01/2018		By Inst.315983/UNION/		1,51,280.00	2,56,665.25	
166	04/01/2018	04/01/2018	19227	ASPER LIST	57,106.00		1,05,385.25	
167	04/01/2018	04/01/2018		CASH DEPOSIT		80,000.00	1,62,491.25	
168	03/01/2018	03/01/2018	19226	ASPER LIST	22,000.00		82,491.25	
169	03/01/2018	03/01/2018		HARIBANDHU PANDA		6,628.00	1,04,491.25	
170	02/01/2018	02/01/2018		IMPSINP2A/800214465057/9 355594011/9016355/INET		12,500.00	97,863.25	GYAN PEETH EDUCATION/Gra m Tran
171	30/12/2017	31/12/2017		Loan Recovery For 14266515002745	9,880.67		85,363.25	Loan Recovery
172	30/12/2017	30/12/2017	19225	14265015002678	10,00,000.00		95,243.92	
173	30/12/2017	30/12/2017		CASH HANDLING CHRGS for 29-12-2017	4.00		10,95,243.92	
174	29/12/2017	29/12/2017		04951131001588		7,00,000.00	10,95,247.92	
175	29/12/2017	29/12/2017		Charges for NEFT Customer Payment :SAA51341402	17.00		3,95,247.92	
176	29/12/2017	29/12/2017	019224	NEFT- OW/SAA51341402/MJR SPORTS CONSULTANCIES	1,31,072.00		3,95,264.92	
177	29/12/2017	29/12/2017		CASH DEPOSIT		1,20,000.00	5,26,336.92	
178	29/12/2017	29/12/2017	19223	SUSANTA KUMAR HATI	8,000.00		4,06,336.92	
179	29/12/2017	29/12/2017		CD- CASH/019601000061/29-12- 2017 10:28		1,100.00	4,14,336.92	14261131000892
180	29/12/2017	29/12/2017		CD- CASH/019601000060/29-12- 2017 10:24		13,900.00	4,13,236.92	14261131000892
181	29/12/2017	29/12/2017		RTGSOIL INDIA LIMITEDKKBKR2201		2,40,954.08	3,99,336.92	RTGSKKBKR220 17122900585182
182	28/12/2017	28/12/2017	19222	ASPER LIST	35,000.00		1,58,382.84	
183	28/12/2017	28/12/2017		Charges for NEFT Customer Payment :SAA51298655	17.00		1,93,382.84	
184	28/12/2017	28/12/2017	019221	NEFT- OW/SAA51298655/GRAM TARANG EMPLOYABILITY	2,00,000.00		1,93,399.84	
185	27/12/2017	27/12/2017		Charges for NEFT Customer Payment :SAA51254886	29.00		3,93,399.84	
186	27/12/2017	27/12/2017	019220	NEFT- OW/SAA51254886/GRAM TARANG EMPLOYABILITY	10,00,000.00		3,93,428.84	
187	27/12/2017	27/12/2017		14261131000663		7,00,000.00	13,93,428.84	
188	26/12/2017	26/12/2017		04951131001588		4,50,000.00	6,93,428.84	
189	26/12/2017	26/12/2017		Charges for NEFT Customer Payment :SAA51205981	29.00		2,43,428.84	
190	26/12/2017	26/12/2017	019219	NEFT- OW/SAA51205981/GRAM TARANG EMPLOYABILITY	5,00,000.00		2,43,457.84	

Account Statement for Account Number 14261131000892

191	26/12/2017	26/12/2017		BANGA-CASH DEPOSIT		1,850.00	7,43,457.84	
192	26/12/2017	26/12/2017		NEWDL-BY INST 192038 : CTS ZONE NO 1		2,25,000.00	7,41,607.84	
193	26/12/2017	26/12/2017		SGST ON CASH HANDLING CHRGs	4.00		5,16,607.84	
194	26/12/2017	26/12/2017		CGST ON CASH HANDLING CHRGs	4.00		5,16,611.84	
195	26/12/2017	26/12/2017		CASH HANDLING CHRGs for 22-12-2017	41.00		5,16,615.84	
196	22/12/2017	22/12/2017		By Inst.162702/SBI/CTS8/SET		20,000.00	5,16,656.84	
197	22/12/2017	22/12/2017	19218	ASPER LIST	1,03,638.00		4,96,656.84	
198	22/12/2017	22/12/2017		CASH DEPOSIT		2,50,000.00	6,00,294.84	
199	21/12/2017	21/12/2017		NEFT-SELCO FOUNDATION		12,420.00	3,50,294.84	NEFT- P1712215897727 8
200	21/12/2017	21/12/2017	19217	ASHA RAM YADAV	20,000.00		3,37,874.84	
201	21/12/2017	21/12/2017		Chrgs for RTGS Cust Pymnt:ORBCH17355085234	60.00		3,57,874.84	
202	21/12/2017	21/12/2017	019216	RTGS- OW/ORBCH17355085234/G RAM TARANG EMPLOYABILITY	10,00,000.00		3,57,934.84	
203	21/12/2017	21/12/2017		04951131001588		4,40,000.00	13,57,934.84	
204	21/12/2017	21/12/2017		SGST ON CASH HANDLING CHRGs	5.00		9,17,934.84	
205	21/12/2017	21/12/2017		CGST ON CASH HANDLING CHRGs	5.00		9,17,939.84	
206	21/12/2017	21/12/2017		CASH HANDLING CHRGs for 20-12-2017	50.00		9,17,944.84	
207	20/12/2017	20/12/2017	19215	ASPER LIST	11,171.00		9,17,994.84	
208	20/12/2017	20/12/2017		CASH DEPOSIT		3,00,000.00	9,29,165.84	
209	20/12/2017	20/12/2017		NEFT-Mr. SANJAY SHUKLA		1,00,000.00	6,29,165.84	NEFT- CBINH17354118 936
210	20/12/2017	20/12/2017		SGST ON CASH HANDLING CHRGs	7.00		5,29,165.84	
211	20/12/2017	20/12/2017		CGST ON CASH HANDLING CHRGs	7.00		5,29,172.84	
212	20/12/2017	20/12/2017		CASH HANDLING CHRGs for 19-12-2017	77.00		5,29,179.84	
213	19/12/2017	19/12/2017	19213	AS PER LIST	28,014.00		5,29,256.84	
214	19/12/2017	19/12/2017		CASH DEPOSIT		4,00,000.00	5,57,270.84	
215	19/12/2017	19/12/2017		Charges for NEFT Customer Payment :SAA51015269	17.00		1,57,270.84	NEFT
216	19/12/2017	19/12/2017	019212	NEFT- OW/SAA51015269/GRAM TARANG EMPLOYABILITY	2,00,000.00		1,57,287.84	NEFT
217	19/12/2017	19/12/2017		Charges for NEFT Customer Payment :SAA51015710	12.00		3,57,287.84	NEFT
218	19/12/2017	19/12/2017	019214	NEFT- OW/SAA51015710/DINESH KUMAR SINGH	15,165.00		3,57,299.84	NEFT

Account Statement for Account Number 14261131000892

219	19/12/2017	19/12/2017		NEFT-BALAJI TRADING		7,400.00	3,72,464.84	NEFT- P1712190458352 3
220	18/12/2017	18/12/2017	19210	ASPER LIST	16,000.00		3,65,064.84	
221	18/12/2017	18/12/2017	19211	ASPER LIST	50,000.00		3,81,064.84	
222	18/12/2017	18/12/2017		NEFT-OIL INDIA LIMITED		59,033.98	4,31,064.84	NEFT- KKBK173526202 369
223	18/12/2017	18/12/2017		SGST ON CASH HANDLING CHRGs	3.00		3,72,030.86	
224	18/12/2017	18/12/2017		CGST ON CASH HANDLING CHRGs	3.00		3,72,033.86	
225	18/12/2017	18/12/2017		CASH HANDLING CHRGs for 16-12-2017	28.00		3,72,036.86	
226	16/12/2017	16/12/2017		NEFT-ADARSH PARAMEDICAL WELFAR		30,000.00	3,72,064.86	NEFT- PUNBH17350053 637
227	16/12/2017	16/12/2017		NEFT-SAGARIKA NANDA		21,400.00	3,42,064.86	NEFT- SBIN2173506260 80
228	16/12/2017	16/12/2017	19208	ASPER LIST	37,512.00		3,20,664.86	
229	16/12/2017	16/12/2017	19209	ASPER LIST	20,000.00		3,58,176.86	
230	16/12/2017	16/12/2017		CASH DEPOSIT		2,00,000.00	3,78,176.86	
231	15/12/2017	15/12/2017	19207	ASPER LIST	2,70,028.00		1,78,176.86	
232	14/12/2017	14/12/2017		Charges for NEFT Customer Payment :SAA50846394	12.00		4,48,204.86	
233	14/12/2017	14/12/2017	019206	NEFT- OW/SAA50846394/MAHEND RA SINGH	3,000.00		4,48,216.86	
234	14/12/2017	14/12/2017	19205	ASPER LIST	88,027.00		4,51,216.86	
235	13/12/2017	13/12/2017		Charges for NEFT Customer Payment :SAA50808049	29.00		5,39,243.86	
236	13/12/2017	13/12/2017	019204	NEFT- OW/SAA50808049/GRAM TARANG EMPLOYABILITY	20,00,000.00		5,39,272.86	
237	13/12/2017	13/12/2017	19203	ASPER LIST	13,27,115.00		25,39,272.86	
238	13/12/2017	13/12/2017		TUNDL-CASH DEPOSIT		10,000.00	38,66,387.86	
239	13/12/2017	13/12/2017		SGST ON CASH HANDLING CHRGs	1.00		38,56,387.86	
240	13/12/2017	13/12/2017		CGST ON CASH HANDLING CHRGs	1.00		38,56,388.86	
241	13/12/2017	13/12/2017		CASH HANDLING CHRGs for 12-12-2017	9.00		38,56,389.86	
242	12/12/2017	12/12/2017		NEFT-WESTERN REFRIGERATION PVT		36,54,778.00	38,56,398.86	NEFT- BTOM173460246 274
243	12/12/2017	12/12/2017		BHOPA-DEEKESH SHARMA		7,800.00	2,01,620.86	
244	12/12/2017	12/12/2017	19202	ASPER LIST	18,878.00		1,93,820.86	
245	12/12/2017	12/12/2017		LUDHI-CASH DEPOSIT		1,47,500.00	2,12,698.86	
246	11/12/2017	11/12/2017	19201	ASPER LIST	17,000.00		65,198.86	
247	11/12/2017	11/12/2017		GTET		50,000.00	82,198.86	
248	08/12/2017	08/12/2017		By Inst.1231/HDFCBANK/CTS8/ SET 12		2,014.00	32,198.86	

Account Statement for Account Number 14261131000892

249	08/12/2017	08/12/2017	19192	NEW GLASS CENTRE	10,270.00		30,184.86	Zone Serial [80]
250	08/12/2017	08/12/2017	19197	RATNAKAR DAS HARDWARE STO	22,570.00		40,454.86	Zone Serial [78]
251	07/12/2017	07/12/2017	19200	AS PER LIST	2,11,000.00		63,024.86	
252	07/12/2017	07/12/2017		Charges for NEFT Customer Payment :SAA50599483	12.00		2,74,024.86	NEFT
253	07/12/2017	07/12/2017	019198	NEFT- OW/SAA50599483/ANANTA KUMAR RAY	40,200.00		2,74,036.86	NEFT
254	07/12/2017	07/12/2017		Charges for NEFT Customer Payment :SAA50599921	12.00		3,14,236.86	NEFT
255	07/12/2017	07/12/2017	019199	NEFT- OW/SAA50599921/GRAM TARANG EMPLOYABILITY	1,00,000.00		3,14,248.86	NEFT
256	07/12/2017	07/12/2017		BHOPA-DEEKESH SHARMA		13,000.00	4,14,248.86	
257	06/12/2017	06/12/2017	19195	AS PER LIST	8,400.00		4,01,248.86	
258	06/12/2017	06/12/2017		BY GTET		3,50,000.00	4,09,648.86	
259	06/12/2017	06/12/2017		Charges for NEFT Customer Payment :SAA50547300	12.00		59,648.86	NEFT
260	06/12/2017	06/12/2017	019196	NEFT- OW/SAA50547300/MOHANT Y MANPOWER SERVICES	1,00,000.00		59,660.86	NEFT
261	05/12/2017	05/12/2017		Charges for NEFT Customer Payment :SAA50509658	12.00		1,59,660.86	
262	05/12/2017	05/12/2017	019193	NEFT- OW/SAA50509658/AJAY KUMAR ROUT	64,108.00		1,59,672.86	
263	05/12/2017	05/12/2017	19194	ASPER LIST	40,000.00		2,23,780.86	
264	04/12/2017	04/12/2017		NEFT-GRAM TARANG EMPLOYABILITY		2,00,000.00	2,63,780.86	NEFT- IBKL1712044116 93
265	04/12/2017	04/12/2017		Charges for NEFT Customer Payment :SAA50455724	12.00		63,780.86	
266	04/12/2017	04/12/2017	019191	NEFT- OW/SAA50455724/DEEPAK GUPTA	25,000.00		63,792.86	
267	04/12/2017	04/12/2017	19190	ASPER LIST	1,07,000.00		88,792.86	
268	02/12/2017	02/12/2017	19189	ASPER LIST	60,000.00		1,95,792.86	
269	02/12/2017	02/12/2017		Chrgs for RTGS Cust Pymnt:ORBCH17336098103	60.00		2,55,792.86	
270	02/12/2017	02/12/2017	019187	RTGS- OW/ORBCH17336098103/G RAM TARANG EMPLOYABILITY	20,00,000.00		2,55,852.86	
271	02/12/2017	02/12/2017	19188	ASPER LIST	38,882.00		22,55,852.86	
272	02/12/2017	02/12/2017		04951131001588		18,50,000.00	22,94,734.86	
273	02/12/2017	02/12/2017	19180	LCC CMS POOL A C NON UTI	1,015.00		4,44,734.86	Zone Serial [150]
274	01/12/2017	01/12/2017	19185	ASPER LIST	30,000.00		4,45,749.86	

Account Statement for Account Number 14261131000892

275	01/12/2017	01/12/2017		Charges for NEFT Customer Payment :SAA50383353	17.00		4,75,749.86	
276	01/12/2017	01/12/2017	019186	NEFT-OW/SAA50383353/GRAM TARANG EMPLOYABILITY	2,00,000.00		4,75,766.86	
277	30/11/2017	30/11/2017		Loan Recovery For 14266515002745	9,880.80		6,75,766.86	Loan Recovery
278	30/11/2017	30/11/2017	19183	ASPER LIST	2,89,891.00		6,85,647.66	
279	30/11/2017	30/11/2017		Charges for NEFT Customer Payment :SAA50340762	17.00		9,75,538.66	
280	30/11/2017	30/11/2017	019182	NEFT-OW/SAA50340762/DHARME SH BHANDARI	1,23,374.00		9,75,555.66	
281	30/11/2017	30/11/2017		Charges for NEFT Customer Payment :SAA50341456	17.00		10,98,929.66	
282	30/11/2017	30/11/2017	019181	NEFT-OW/SAA50341456/MJR SPORTS CONSULTANCIES	1,73,685.00		10,98,946.66	
283	30/11/2017	30/11/2017		CASH DEPOSIT		1,00,000.00	12,72,631.66	
284	30/11/2017	30/11/2017		NEFT-OSDA		1,15,718.00	11,72,631.66	NEFT-SBIN717334312368
285	30/11/2017	30/11/2017		NEFT-OSDA		1,30,183.00	10,56,913.66	NEFT-SBIN717334310769
286	30/11/2017	30/11/2017		NEFT-OSDA		50,627.00	9,26,730.66	NEFT-SBIN717334307937
287	30/11/2017	30/11/2017		NEFT-OSDA		1,22,951.00	8,76,103.66	NEFT-SBIN717334307068
288	30/11/2017	30/11/2017		NEFT-OSDA		1,22,951.00	7,53,152.66	NEFT-SBIN717334306209
289	30/11/2017	30/11/2017		NEFT-AKSHAY KUMAR SHARMA		20,800.00	6,30,201.66	NEFT-SAA314438379
290	29/11/2017	29/11/2017		NEFT-RETURN-SAA50301599		1,73,685.00	6,09,401.66	CITIN17857900037-R01-
291	29/11/2017	29/11/2017		Charges for NEFT Customer Payment :SAA50301921	17.00		4,35,716.66	
292	29/11/2017	29/11/2017	019179	NEFT-OW/SAA50301921/MS IMC OF ITI JAMSHEDPUR	1,30,000.00		4,35,733.66	
293	29/11/2017	29/11/2017		Charges for NEFT Customer Payment :SAA50301599	17.00		5,65,733.66	
294	29/11/2017	29/11/2017	019178	NEFT-OW/SAA50301599/MJR SPORTS CONSULTANCIES	1,73,685.00		5,65,750.66	
295	29/11/2017	29/11/2017		14261131001400		6,00,000.00	7,39,435.66	
296	28/11/2017	28/11/2017	19177	ASPER LIST	57,500.00		1,39,435.66	
297	28/11/2017	28/11/2017		CASH DEPOSIT		1,00,000.00	1,96,935.66	
298	27/11/2017	27/11/2017	19176	ASPER LIST	2,03,693.00		96,935.66	

Account Statement for Account Number 14261131000892

299	27/11/2017	27/11/2017		Charges for NEFT Customer Payment :SAA50212967	17.00		3,00,628.66	
300	27/11/2017	27/11/2017	019175	NEFT-OW/SAA50212967/PRADEE P KUMAR SARANGI	1,49,569.00		3,00,645.66	
301	27/11/2017	27/11/2017		NEFT-AKSHAY KUMAR SHARMA		17,500.00	4,50,214.66	NEFT-SAA313424969
302	24/11/2017	24/11/2017	19174	ASPER LIST	13,622.00		4,32,714.66	
303	24/11/2017	24/11/2017		BALGA-CASH DEPOSIT		2,500.00	4,46,336.66	
304	23/11/2017	23/11/2017		Charges for NEFT Customer Payment :SAA50121399	12.00		4,43,836.66	
305	23/11/2017	23/11/2017	019172	NEFT-OW/SAA50121399/CESU KED KHURDA	9,544.00		4,43,848.66	
306	23/11/2017	23/11/2017		Charges for NEFT Customer Payment :SAA50120426	12.00		4,53,392.66	
307	23/11/2017	23/11/2017	019170	NEFT-OW/SAA50120426/NIHAR RANJAN PANDA	16,317.00		4,53,404.66	
308	23/11/2017	23/11/2017		Charges for NEFT Customer Payment :SAA50120916	12.00		4,69,721.66	
309	23/11/2017	23/11/2017	019173	NEFT-OW/SAA50120916/CESU KED KHURDA	2,905.00		4,69,733.66	
310	23/11/2017	23/11/2017	19171	ASPER LIST	52,131.00		4,72,638.66	
311	23/11/2017	23/11/2017		NEFT-M/s. RSM SKILL DEVELOPMEN		7,500.00	5,24,769.66	NEFT-ALLAH17327441332
312	23/11/2017	23/11/2017		COIMB-K G CENTURION		42,500.00	5,17,269.66	
313	22/11/2017	22/11/2017	19168	ASPER LIST	1,42,000.00		4,74,769.66	
314	22/11/2017	22/11/2017		Charges for NEFT Customer Payment :SAA50085551	17.00		6,16,769.66	
315	22/11/2017	22/11/2017	019166	NEFT-OW/SAA50085551/JAWAHAR ALI KHAN PATHAN	1,12,500.00		6,16,786.66	
316	22/11/2017	22/11/2017		Charges for NEFT Customer Payment :SAA50085756	17.00		7,29,286.66	
317	22/11/2017	22/11/2017	019167	NEFT-OW/SAA50085756/VENKAT ASHAA	1,03,500.00		7,29,303.66	
318	22/11/2017	22/11/2017		Charges for NEFT Customer Payment :SAA50086233	17.00		8,32,803.66	
319	22/11/2017	22/11/2017	019165	NEFT-OW/SAA50086233/USHA JYOTI MEKA	1,35,000.00		8,32,820.66	
320	22/11/2017	22/11/2017	19169	RANJEET YADAV	20,000.00		9,67,820.66	
321	21/11/2017	21/11/2017		NEFT-DE OSDA		3,57,012.00	9,87,820.66	NEFT-SBIN117325014563
322	21/11/2017	21/11/2017		NEFT-DE OSDA		3,02,553.00	6,30,808.66	NEFT-SBIN117325012051

Account Statement for Account Number 14261131000892

323	21/11/2017	21/11/2017		NEFT-DE OSDA		2,86,325.00	3,28,255.66	NEFT-SBIN17325007609
324	20/11/2017	20/11/2017	19164	ASPER LIST	1,43,210.00		41,930.66	
325	18/11/2017	18/11/2017	19163	ASPER LIST	20,695.00		1,85,140.66	
326	18/11/2017	18/11/2017		NEFT-FEEDBACK ENERGY DISTRIBUT		1,79,356.00	2,05,835.66	NEFT-SBIN817321365710
327	17/11/2017	17/11/2017	19162	ASPER LIST	4,04,915.00		26,479.66	
328	17/11/2017	17/11/2017		IMPSINP2A/732116196444/9213221221/9240000/INET		2,500.00	4,31,394.66	RNG INSTITUTE OF MGM/Deepak Is
329	16/11/2017	16/11/2017		NEFT-DE OSDA		1,01,430.00	4,28,894.66	NEFT-SBIN717320244018
330	16/11/2017	16/11/2017		NEFT-DE OSDA		20,580.00	3,27,464.66	NEFT-SBIN717320241912
331	16/11/2017	16/11/2017		NEFT-DE OSDA		98,784.00	3,06,884.66	NEFT-SBIN717320246783
332	16/11/2017	16/11/2017		NEFT-DE OSDA		21,168.00	2,08,100.66	NEFT-SBIN717320247665
333	16/11/2017	16/11/2017		NEFT-DE OSDA		94,080.00	1,86,932.66	NEFT-SBIN717320245711
334	16/11/2017	16/11/2017		NEFT-DE OSDA		16,537.00	92,852.66	NEFT-SBIN717320242723
335	16/11/2017	16/11/2017		Chrgs for RTGS Cust Pymnt:ORBCH17320044912	29.00		76,315.66	
336	16/11/2017	16/11/2017	019160	RTGS-OW/ORBCH17320044912/COUNCIL OF ANALITICAL TRI	4,30,830.00		76,344.66	
337	16/11/2017	16/11/2017		Chrgs for RTGS Cust Pymnt:ORBCH17320045406	60.00		5,07,174.66	
338	16/11/2017	16/11/2017	019161	RTGS-OW/ORBCH17320045406/G RAM TARANG EMPLOYABILITY	5,50,000.00		5,07,234.66	
339	15/11/2017	15/11/2017		NEFT-RAM SINGH COLLEGE OF ENGI		5,40,000.00	10,57,234.66	NEFT-PUNBH17319452109
340	15/11/2017	15/11/2017		NEFT-MAYA ENGINEERING WOR		2,32,500.00	5,17,234.66	NEFT-P17111535173589
341	15/11/2017	15/11/2017		Charges for NEFT Customer Payment :SAA49833158	17.00		2,84,734.66	
342	15/11/2017	15/11/2017	019158	NEFT-OW/SAA49833158/GRAM TARANG EMPLOYABILITY	1,50,000.00		2,84,751.66	
343	15/11/2017	15/11/2017	19157	ASPER LIST	58,000.00		4,34,751.66	
344	15/11/2017	15/11/2017	19159	14265015002678	5,00,000.00		4,92,751.66	

Account Statement for Account Number 14261131000892

345	15/11/2017	15/11/2017		NEFT-GYAN SHAKTI PRIVATE		13,000.00	9,92,751.66	NEFT-N319170061706482
346	15/11/2017	15/11/2017		NEFT-SHREE JAGANNATH PRIVATE I		36,400.00	9,79,751.66	NEFT-N319170410718426
347	14/11/2017	14/11/2017		NEFT-INDRAPRASTHA AUTOMOBILES		26,000.00	9,43,351.66	NEFT-N318170410201973
348	14/11/2017	14/11/2017		NEFT-WORLD WORKERS PVT ITI		83,200.00	9,17,351.66	NEFT-VJBBH17318032438
349	14/11/2017	14/11/2017		RTGSOIL INDIA LIMITEDKKBKR2201		7,22,863.80	8,34,151.66	RTGSKKBKR22017111400366491
350	13/11/2017	13/11/2017	19156	ASPER LISTTRANSFER TXN	27,64,000.00		1,11,287.86	
351	10/11/2017	10/11/2017		NEFT-WESTERN REFRIGERATION PVT		27,23,278.00	28,75,287.86	NEFT-BTOM173140182118
352	10/11/2017	10/11/2017		COIMB-K G CENTURION		44,500.00	1,52,009.86	
353	10/11/2017	10/11/2017	19155	RANJEET YADAV	35,400.00		1,07,509.86	
354	10/11/2017	10/11/2017	19154	ASPER LIST	45,000.00		1,42,909.86	
355	09/11/2017	09/11/2017		BY 04951131001588		1,00,000.00	1,87,909.86	
356	09/11/2017	09/11/2017		BHUBA-BY CENTURION SCIENCE & TECHNOLOGY ENTERPRENE		36,472.00	87,909.86	
357	08/11/2017	08/11/2017		Charges for NEFT Customer Payment :SAA49586059	29.00		51,437.86	
358	08/11/2017	08/11/2017	019153	NEFT-OW/SAA49586059/GRAM TARANG EMPLOYABILITY	11,00,000.00		51,466.86	
359	08/11/2017	08/11/2017	19152	ASPER LIST	2,30,000.00		11,51,466.86	
360	08/11/2017	08/11/2017		14261131000892 GTET		12,90,000.00	13,81,466.86	
361	04/11/2017	04/11/2017	19151	ASPER LIST	8,000.00		91,466.86	
362	04/11/2017	04/11/2017	19049	ASPER LIST	25,950.00		99,466.86	
363	03/11/2017	03/11/2017	19048	ASPER LIST	38,291.00		1,25,416.86	
364	03/11/2017	03/11/2017		Charges for NEFT Customer Payment :SAA49416612	12.00		1,63,707.86	
365	03/11/2017	03/11/2017	019050	NEFT-OW/SAA49416612/DEEPAK KUMAR DIWAKAR	7,000.00		1,63,719.86	
366	02/11/2017	02/11/2017		PURNA CHANDRA MOHAKHUD		10,000.00	1,70,719.86	
367	31/10/2017	31/10/2017		Loan Recovery For 14266515002745	9,880.11		1,60,719.86	Loan Recovery
368	31/10/2017	31/10/2017	19046	ASPER LIST	90,952.00		1,70,599.97	
369	31/10/2017	31/10/2017	19047	ASPER LIST	16,929.00		2,61,551.97	
370	31/10/2017	31/10/2017		SGST ON CASH HANDLING CHRGS	2.00		2,78,480.97	
371	31/10/2017	31/10/2017		CGST ON CASH HANDLING CHRGS	2.00		2,78,482.97	
372	31/10/2017	31/10/2017		CASH HANDLING CHRGS for 30-10-2017	24.00		2,78,484.97	

Account Statement for Account Number 14261131000892

373	30/10/2017	30/10/2017		NEFT-HANON CLIMATE SYSTEMS IND		60,332.74	2,78,508.97	NEFT-28102017016924
374	30/10/2017	30/10/2017		CASH DEPOSIT		1,13,000.00	2,18,176.23	
375	30/10/2017	30/10/2017		LUDHI-CASH DEPOSIT		73,500.00	1,05,176.23	
376	26/10/2017	26/10/2017	19045	ASPER	31,332.00		31,676.23	
377	25/10/2017	25/10/2017	19042	BULK NEFT	7,38,910.00		63,008.23	
378	25/10/2017	25/10/2017		GTET 14261131000663		90,000.00	8,01,918.23	
379	25/10/2017	25/10/2017	19041	ASPER LIST	19,648.00		7,11,918.23	
380	25/10/2017	25/10/2017		Charges for NEFT Customer Payment :SAA49118859	12.00		7,31,566.23	
381	25/10/2017	25/10/2017	019044	NEFT-OW/SAA49118859/BRIGHT STEEL	73,285.00		7,31,578.23	
382	24/10/2017	24/10/2017		By Inst.22163/BOI/CTS8/SET 5		1,00,000.00	8,04,863.23	
383	24/10/2017	24/10/2017		By Inst.22164/BOI/CTS8/SET 4		55,400.00	7,04,863.23	
384	24/10/2017	24/10/2017		GTET 14265015002678		30,000.00	6,49,463.23	
385	23/10/2017	23/10/2017		Charges for NEFT Customer Payment :SAA49034967	17.00		6,19,463.23	
386	23/10/2017	23/10/2017	019040	NEFT-OW/SAA49034967/AJAY KUMAR ROUT	1,38,181.00		6,19,480.23	
387	23/10/2017	23/10/2017		Charges for NEFT Customer Payment :SAA49031259	12.00		7,57,661.23	
388	23/10/2017	23/10/2017	019038	NEFT-OW/SAA49031259/CESU KED KHURDA	10,574.00		7,57,673.23	
389	23/10/2017	23/10/2017		Charges for NEFT Customer Payment :SAA49031759	12.00		7,68,247.23	
390	23/10/2017	23/10/2017	019039	NEFT-OW/SAA49031759/CESU KED KHURDA	3,370.00		7,68,259.23	
391	23/10/2017	23/10/2017	19037	ASPR LIST	2,36,016.00		7,71,629.23	
392	23/10/2017	23/10/2017		RTGSGRAM TARANG EMPLOYABILITY		9,00,000.00	10,07,645.23	RTGSUTIBR52017102300356732
393	23/10/2017	23/10/2017		By Inst.46980/CITIBANK/CTS8/SET 2		1,03,521.00	1,07,645.23	
394	21/10/2017	21/10/2017		Charges for NEFT Customer Payment :SAA48993793	12.00		4,124.23	
395	21/10/2017	21/10/2017	019036	NEFT-OW/SAA48993793/MUKESH ARYA	5,000.00		4,136.23	
396	18/10/2017	18/10/2017		Charges for NEFT Customer Payment :SAA48961544	29.00		9,136.23	
397	18/10/2017	18/10/2017	019034	NEFT-OW/SAA48961544/RBI	7,50,643.00		9,165.23	
398	18/10/2017	18/10/2017	19035	LABANYA PRESS	40,000.00		7,59,808.23	

Account Statement for Account Number 14261131000892

399	18/10/2017	18/10/2017		Charges for NEFT Customer Payment :SAA48930167	12.00		7,99,808.23	
400	18/10/2017	18/10/2017	019031	NEFT-OW/SAA48930167/MAHENDRA SINGH	30,000.00		7,99,820.23	
401	18/10/2017	18/10/2017		Charges for NEFT Customer Payment :SAA48930594	12.00		8,29,820.23	
402	18/10/2017	18/10/2017	019032	NEFT-OW/SAA48930594/TANIYA MUKHARJEE	15,527.00		8,29,832.23	
403	17/10/2017	17/10/2017		Charges for NEFT Customer Payment :SAA48902482	17.00		8,45,359.23	
404	17/10/2017	17/10/2017	019033	NEFT-OW/SAA48902482/KELU CHARAN PRADHAN	1,17,000.00		8,45,376.23	
405	17/10/2017	17/10/2017	19029	ASPER LIST	76,321.00		9,62,376.23	
406	17/10/2017	17/10/2017		Charges for NEFT Customer Payment :SAA48901996	12.00		10,38,697.23	
407	17/10/2017	17/10/2017	019030	NEFT-OW/SAA48901996/ANANTA KUMAR RAY	30,000.00		10,38,709.23	
408	16/10/2017	16/10/2017		KAMRU-20161131000346		9,00,000.00	10,68,709.23	
409	16/10/2017	16/10/2017		Charges for NEFT Customer Payment :SAA48838776	29.00		1,68,709.23	
410	16/10/2017	16/10/2017	019027	NEFT-OW/SAA48838776/GRAM TARANG EMPLOYABILITY	4,00,000.00		1,68,738.23	
411	16/10/2017	16/10/2017	19028	ASPER LIST	58,140.00		5,68,738.23	
412	16/10/2017	16/10/2017		NEFT-BALAJI TRADING		10,000.00	6,26,878.23	NEFT-P17101685876548
413	16/10/2017	16/10/2017		GTET 04951131001588		4,00,000.00	6,16,878.23	
414	13/10/2017	13/10/2017		NEFT-HANON CLIMATE SYSTEMS IND		80,989.35	2,16,878.23	NEFT-13102017016852
415	13/10/2017	13/10/2017	19026	DEBENDRA KUMAR SAHOO	10,000.00		1,35,888.88	
416	13/10/2017	13/10/2017		SGST TAX	1.00		1,45,888.88	
417	13/10/2017	13/10/2017		CGST TAX	1.00		1,45,889.88	
418	13/10/2017	13/10/2017		SMS CHARGES from 01-07-2017 to 30-09-2017	15.00		1,45,890.88	
419	12/10/2017	12/10/2017	19025	BULK NEFT	91,266.00		1,45,905.88	
420	12/10/2017	12/10/2017	19024	ASPER LIST	29,560.00		2,37,171.88	
421	11/10/2017	11/10/2017		NEFT-GRAM TARANG EMPLOYABILITY		13,064.00	2,66,731.88	NEFT-IBKL171011370180
422	11/10/2017	11/10/2017		NEFT-GRAM TARANG EMPLOYABILITY		13,064.00	2,53,667.88	NEFT-IBKL171011370151
423	11/10/2017	11/10/2017		NEFT-GRAM TARANG EMPLOYABILITY		13,500.00	2,40,603.88	NEFT-IBKL171011370119

Account Statement for Account Number 14261131000892

424	11/10/2017	11/10/2017		NEFT-INDIAMART		5,000.00	2,27,103.88	NEFT- N2841700535940 95
425	10/10/2017	10/10/2017	19023	ASPER LIST	71,000.00		2,22,103.88	
426	10/10/2017	10/10/2017		GTET 04951131001588		1,00,000.00	2,93,103.88	
427	09/10/2017	09/10/2017		Charges for NEFT Customer Payment :SAA48587943	29.00		1,93,103.88	
428	09/10/2017	09/10/2017	019018	NEFT- OW/SAA48587943/GRAM TARANG EMPLOYABILITY	19,00,000.00		1,93,132.88	
429	09/10/2017	09/10/2017		Charges for NEFT Customer Payment :SAA48588395	29.00		20,93,132.88	
430	09/10/2017	09/10/2017	019020	NEFT- OW/SAA48588395/GRAM TARANG EMPLOYABILITY	2,50,000.00		20,93,161.88	
431	09/10/2017	09/10/2017	19021	ASPER LIST	1,65,768.00		23,43,161.88	
432	09/10/2017	09/10/2017		Charges for NEFT Customer Payment :SAA48586694	29.00		25,08,929.88	
433	09/10/2017	09/10/2017	019017	NEFT- OW/SAA48586694/GRAM TARANG EMPLOYABILITY	3,50,000.00		25,08,958.88	
434	09/10/2017	09/10/2017		Charges for NEFT Customer Payment :SAA48587228	12.00		28,58,958.88	
435	09/10/2017	09/10/2017	019019	NEFT- OW/SAA48587228/GRAM TARANG EMPLOYABILITY	63,000.00		28,58,970.88	
436	09/10/2017	09/10/2017		CHQ NO-226206 RETURN DUE TO PAYMENT STOPPED BY DRA	97,400.00		29,21,970.88	
437	09/10/2017	09/10/2017		By Inst.226206/CORPN/CTS8/S ET 4		97,400.00	30,19,370.88	
438	07/10/2017	07/10/2017		NEFT-WESTERN REFRIGERATION PVT		28,51,849.00	29,21,970.88	NEFT- BTOM172800107 426
439	07/10/2017	07/10/2017		Charges for NEFT Customer Payment :SAA48542241	12.00		70,121.88	
440	07/10/2017	07/10/2017	019015	NEFT- OW/SAA48542241/HEMANT HIRALAL BHANDARI	50,000.00		70,133.88	
441	07/10/2017	07/10/2017		Charges for NEFT Customer Payment :SAA48541985	12.00		1,20,133.88	
442	07/10/2017	07/10/2017	019013	NEFT-OW/SAA48541985/MS MOHANTY MANPOWER SERVI	50,000.00		1,20,145.88	
443	07/10/2017	07/10/2017		Charges for NEFT Customer Payment :SAA48541857	29.00		1,70,145.88	
444	07/10/2017	07/10/2017	019016	NEFT- OW/SAA48541857/GRAM TARANG EMPLOYABILITY	11,00,000.00		1,70,174.88	
445	07/10/2017	07/10/2017		GTET 04951131001588		11,00,000.00	12,70,174.88	
446	07/10/2017	07/10/2017	19014	ANANDA PRADHAN	20,000.00		1,70,174.88	

Account Statement for Account Number 14261131000892

447	06/10/2017	06/10/2017		LUDHI-CASH DEPOSIT		80,000.00	1,90,174.88	
448	04/10/2017	04/10/2017	19012	ASPER LIST	33,000.00		1,10,174.88	
449	03/10/2017	03/10/2017	19011	ASPER LIST	2,66,938.00		1,43,174.88	
450	30/09/2017	30/09/2017		Loan Recovery For 14266515002745	9,880.76		4,10,112.88	Loan Recovery
451	29/09/2017	29/09/2017		Charges for NEFT Customer Payment :SAA48292345	12.00		4,19,993.64	
452	29/09/2017	29/09/2017	19009	NEFT- OW/SAA48292345/MAHEND RA SINGH	34,800.00		4,20,005.64	
453	27/09/2017	27/09/2017		By Inst.185432/SBI/CTS8/SET		6,360.00	4,54,805.64	
454	27/09/2017	27/09/2017		By Inst.226205/CORPN/CTS8/S ET 4		1,00,000.00	4,48,445.64	
455	27/09/2017	27/09/2017	19010	ASPER LIST	28,000.00		3,48,445.64	
456	27/09/2017	27/09/2017		Charges for NEFT Customer Payment :SAA48222335	12.00		3,76,445.64	
457	27/09/2017	27/09/2017	019007	NEFT- OW/SAA48222335/SUGYAN RANJAN DALAI	48,374.00		3,76,457.64	
458	27/09/2017	27/09/2017		14261131000892 GTET		3,00,000.00	4,24,831.64	
459	27/09/2017	27/09/2017	19008	SELF	70,000.00		1,24,831.64	
460	26/09/2017	26/09/2017	19006	BULK NEFT	4,72,991.00		1,94,831.64	
461	26/09/2017	26/09/2017		14265015002678		6,00,000.00	6,67,822.64	
462	26/09/2017	26/09/2017	19005	SALARYSEPT17	2,66,596.00		67,822.64	
463	26/09/2017	26/09/2017		Charges for NEFT Customer Payment :SAA48184467	12.00		3,34,418.64	
464	26/09/2017	26/09/2017	019004	NEFT- OW/SAA48184467/UDHAV KARMAKAR	54,500.00		3,34,430.64	
465	26/09/2017	26/09/2017		14265015002678		2,00,000.00	3,88,930.64	
466	25/09/2017	25/09/2017		Charges for NEFT Customer Payment :SAA48148509	29.00		1,88,930.64	
467	25/09/2017	25/09/2017	019002	NEFT- OW/SAA48148509/GRAM TARANG EMPLOYABILITY	5,00,000.00		1,88,959.64	
468	25/09/2017	25/09/2017		04951131001588		5,40,000.00	6,88,959.64	
469	25/09/2017	25/09/2017	19003	SELF	50,000.00		1,48,959.64	
470	22/09/2017	22/09/2017	19000	ASPER LIST	1,10,000.00		1,98,959.64	
471	22/09/2017	22/09/2017	18999	BULK NEFT	1,26,453.00		3,08,959.64	
472	22/09/2017	22/09/2017		Charges for NEFT Customer Payment :SAA48094822	29.00		4,35,412.64	
473	22/09/2017	22/09/2017	19001	NEFT- OW/SAA48094822/GRAM TARANG EMPLOYABILITY	5,00,000.00		4,35,441.64	
474	21/09/2017	21/09/2017		BY GTET 04951131001588		70,000.00	9,35,441.64	
475	21/09/2017	21/09/2017		RTGSODISHA SKILL DEVELOPMENT A		3,75,821.00	8,65,441.64	RTGSSBINR5201 7092100056041

Account Statement for Account Number 14261131000892

476	21/09/2017	21/09/2017		Charges for NEFT Customer Payment :SAA48047470	12.00		4,89,620.64	
477	21/09/2017	21/09/2017	18998	NEFT-OW/SAA48047470/UTTAR PRADESH SKILL DEVEL	10,000.00		4,89,632.64	
478	21/09/2017	21/09/2017		RTGSODISHA SKILL DEVELOPMENT A		3,89,476.00	4,99,632.64	RTGSSBINR52017092100055924
479	20/09/2017	20/09/2017	18993	AS PER LIST	1,22,169.00		1,10,156.64	
480	20/09/2017	20/09/2017		04951131001588		1,00,000.00	2,32,325.64	
481	20/09/2017	20/09/2017		Charges for NEFT Customer Payment :SAA48004617	17.00		1,32,325.64	
482	20/09/2017	20/09/2017	18996	NEFT-OW/SAA48004617/INDIA SKILLS PVT LTD	1,59,418.00		1,32,342.64	
483	20/09/2017	20/09/2017		Charges for NEFT Customer Payment :SAA48003800	12.00		2,91,760.64	
484	20/09/2017	20/09/2017	18997	NEFT-OW/SAA48003800/RAJNEE SH GUPTA	10,000.00		2,91,772.64	
485	20/09/2017	20/09/2017		Charges for NEFT Customer Payment :SAA48001707	12.00		3,01,772.64	
486	20/09/2017	20/09/2017	18995	NEFT-OW/SAA48001707/MJR SPORTS CONSULTANCIES	85,112.00		3,01,784.64	
487	20/09/2017	20/09/2017		Charges for NEFT Customer Payment :SAA48000983	12.00		3,86,896.64	
488	20/09/2017	20/09/2017	18992	NEFT-OW/SAA48000983/GRAM TARANG EMPLOYABILITY	25,000.00		3,86,908.64	
489	20/09/2017	20/09/2017		Chrgs for RTGS Cust Pymnt:ORBCH17263085549	29.00		4,11,908.64	
490	20/09/2017	20/09/2017	18994	RTGS-OW/ORBCH17263085549/G RAM TARANG EMPLOYABILITY	2,00,000.00		4,11,937.64	
491	18/09/2017	18/09/2017		NEFT-DE OSDA		20,580.00	6,11,937.64	NEFT-SBIN617261892013
492	18/09/2017	18/09/2017		NEFT-DE OSDA		47,040.00	5,91,357.64	NEFT-SBIN617261890683
493	18/09/2017	18/09/2017		NEFT-DE OSDA		26,460.00	5,44,317.64	NEFT-SBIN617261889865
494	18/09/2017	18/09/2017		NEFT-DE OSDA		1,24,950.00	5,17,857.64	NEFT-SBIN617261887940
495	18/09/2017	18/09/2017		NEFT-DE OSDA		20,580.00	3,92,907.64	NEFT-SBIN617261886277
496	18/09/2017	18/09/2017		By Inst.51/HDFCBANK/CTS8/SE T 6		1,00,000.00	3,72,327.64	

Account Statement for Account Number 14261131000892

497	18/09/2017	18/09/2017		CASH HANDLING CHRGS for 16-09-2017	3.00		2,72,327.64	
498	16/09/2017	16/09/2017	18989	AS PER LIST	97,000.00		2,72,330.64	
499	16/09/2017	16/09/2017	18991	AS PER LIST	7,912.00		3,69,330.64	
500	16/09/2017	16/09/2017	18990	AS PER LIST	12,830.00		3,77,242.64	
501	16/09/2017	16/09/2017		LUDHI-CASH DEPOSIT		1,03,500.00	3,90,072.64	
502	15/09/2017	15/09/2017		RSITA-GTET		2,00,000.00	2,86,572.64	
503	15/09/2017	15/09/2017	18988	AS PER LIST	39,885.00		86,572.64	
504	15/09/2017	15/09/2017		By Inst.119969/CORPN/CTS8/ ET 8		60,000.00	1,26,457.64	
505	15/09/2017	15/09/2017		By Inst.186115/CANARA/CTS8/ SET 6		10,000.00	66,457.64	
506	14/09/2017	14/09/2017		Charges for NEFT Customer Payment :SAA47816336	12.00		56,457.64	
507	14/09/2017	14/09/2017	18986	NEFT- OW/SAA47816336/GRAM TARANG EMPLOYABILITY	16,500.00		56,469.64	
508	14/09/2017	14/09/2017		Charges for NEFT Customer Payment :SAA47816581	29.00		72,969.64	
509	14/09/2017	14/09/2017	18985	NEFT- OW/SAA47816581/NIRANJA N DASH	5,27,288.00		72,998.64	
510	14/09/2017	14/09/2017		Charges for NEFT Customer Payment :SAA47813263	12.00		6,00,286.64	
511	14/09/2017	14/09/2017	18987	NEFT- OW/SAA47813263/KOVAI ENGINEERING WORKS P	16,800.00		6,00,298.64	
512	14/09/2017	14/09/2017		BY GTET		1,50,000.00	6,17,098.64	
513	13/09/2017	13/09/2017		NEFT-Feedback Energy Distribut		1,67,994.00	4,67,098.64	NEFT- 20170913NOC00 524
514	13/09/2017	13/09/2017	18983	AS PER LIST	66,685.00		2,99,104.64	
515	13/09/2017	13/09/2017		Charges for NEFT Customer Payment :SAA47776949	29.00		3,65,789.64	
516	13/09/2017	13/09/2017	18982	NEFT- OW/SAA47776949/GRAM TARANG EMPLOYABILITY	7,00,000.00		3,65,818.64	
517	13/09/2017	13/09/2017		Charges for NEFT Customer Payment :SAA47776242	12.00		10,65,818.64	
518	13/09/2017	13/09/2017	18984	NEFT- OW/SAA47776242/ANNAPU RNA DEVI	11,378.00		10,65,830.64	
519	13/09/2017	13/09/2017		NEFT-NAVRETI TECHNOLOGIES PRIV		1,360.00	10,77,208.64	NEFT- 03410613917001 22
520	12/09/2017	12/09/2017	18977	SALARYAUG17	2,26,876.00		10,75,848.64	
521	12/09/2017	12/09/2017	18981	AS PER LIST	15,000.00		13,02,724.64	
522	12/09/2017	12/09/2017	18976	NEFT UPLD	4,29,900.00		13,17,724.64	
523	12/09/2017	12/09/2017	18961	THE NEW INIDA	21,500.00		17,47,624.64	Zone Serial [610]

Account Statement for Account Number 14261131000892

524	12/09/2017	12/09/2017	18967	THE NEW INIDA	12,016.00		17,69,124.64	Zone Serial [609]
525	12/09/2017	12/09/2017	18965	SHREE RAGHUNATH STORE	20,000.00		17,81,140.64	Zone Serial [192]
526	12/09/2017	12/09/2017	18978	AS PER LIST	23,579.00		18,01,140.64	
527	11/09/2017	11/09/2017	18974	NEFT BULK UPLD	3,31,663.00		18,24,719.64	
528	11/09/2017	11/09/2017	18975	SRIKANTA CHOUDHARY	5,000.00		21,56,382.64	
529	11/09/2017	11/09/2017	18973	AS PER LIST	15,000.00		21,61,382.64	
530	11/09/2017	11/09/2017		BY GTET		17,60,000.00	21,76,382.64	
531	11/09/2017	11/09/2017		COIMB-KG CENTURION		43,500.00	4,16,382.64	
532	11/09/2017	11/09/2017		Charges for NEFT Customer Payment :SAA47658938	12.00		3,72,882.64	
533	11/09/2017	11/09/2017	18972	NEFT-OW/SAA47658938/SURYA KANTA LENKA	10,000.00		3,72,894.64	
534	08/09/2017	08/09/2017	18971	AS PER LIST	9,216.00		3,82,894.64	
535	08/09/2017	08/09/2017		Charges for NEFT Customer Payment :SAA47626650	12.00		3,92,110.64	
536	08/09/2017	08/09/2017	18970	NEFT-OW/SAA47626650/TRIP SHOPPERS DOT COM	50,000.00		3,92,122.64	
537	08/09/2017	08/09/2017		Chrgs for RTGS Cust Pymnt:ORBCH17251097229	60.00		4,42,122.64	
538	08/09/2017	08/09/2017	18968	RTGS-OW/ORBCH17251097229/G RAM TARANG EMPLOYABILITY	7,00,000.00		4,42,182.64	
539	08/09/2017	08/09/2017	18969	AS PER LIST	40,000.00		11,42,182.64	
540	08/09/2017	08/09/2017		BY GTET		4,00,000.00	11,82,182.64	
541	07/09/2017	07/09/2017		Charges for NEFT Customer Payment :SAA47581205	12.00		7,82,182.64	
542	07/09/2017	07/09/2017	18964	NEFT-OW/SAA47581205/ANURAG DAS	60,000.00		7,82,194.64	
543	07/09/2017	07/09/2017	18962	AS PER LIST	1,67,862.00		8,42,194.64	
544	07/09/2017	07/09/2017		Chrgs for RTGS Cust Pymnt:ORBCH17250060153	60.00		10,10,056.64	
545	07/09/2017	07/09/2017	18963	RTGS-OW/ORBCH17250060153/G RAM TARANG EMPLOYABILITY	15,00,000.00		10,10,116.64	
546	06/09/2017	06/09/2017		NEFT-Mrs. SAGARIKA NANDA		20,000.00	25,10,116.64	NEFT-CBINH17249136 527
547	06/09/2017	06/09/2017	18959	NEFT BULK UPLD	4,59,665.00		24,90,116.64	
548	06/09/2017	06/09/2017	18958	AS PER LIST	28,811.00		29,49,781.64	
549	06/09/2017	06/09/2017	18960	AS PER LIST	15,500.00		29,78,592.64	
550	06/09/2017	06/09/2017		By Inst.291886/SBI/CTS8/SET		20,000.00	29,94,092.64	
551	05/09/2017	05/09/2017		NEFT-WESTERN REFRIGERATION PVT		27,32,414.00	29,74,092.64	NEFT-BTOM172480039 060

Account Statement for Account Number 14261131000892

552	05/09/2017	05/09/2017	18957	AS PER LIST	31,233.00		2,41,678.64	
553	05/09/2017	05/09/2017		BY GTET		2,50,000.00	2,72,911.64	
554	05/09/2017	05/09/2017		Charges for NEFT Customer Payment :SAA47490228	12.00		22,911.64	
555	05/09/2017	05/09/2017	18956	NEFT-OW/SAA47490228/MAHENDAR SINGH	15,000.00		22,923.64	
556	04/09/2017	04/09/2017	18955	AS PER LIST	67,744.00		37,923.64	
557	01/09/2017	01/09/2017	18954	AS PER LIST	11,000.00		1,05,667.64	
558	01/09/2017	01/09/2017	18953	NEFT BULK UPLD	32,000.00		1,16,667.64	
559	31/08/2017	31/08/2017		Loan Recovery For 14266515002745	9,880.13		1,48,667.64	Loan Recovery
560	31/08/2017	31/08/2017		BY GTET		50,000.00	1,58,547.77	
561	31/08/2017	31/08/2017		BY GTET		1,00,000.00	1,08,547.77	
562	30/08/2017	30/08/2017	17100	AS PER LIST	1,12,060.00		8,547.77	
563	30/08/2017	30/08/2017		BY GTET/04951131001588		20,000.00	1,20,607.77	
564	30/08/2017	30/08/2017	18952	BULK NEFT	49,965.00		1,00,607.77	
565	30/08/2017	30/08/2017		Charges for NEFT Customer Payment :SAA47317925	12.00		1,50,572.77	NEFT
566	30/08/2017	30/08/2017	018951	NEFT-OW/SAA47317925/THE INDIAN EXPRESS PVT LT	85,500.00		1,50,584.77	NEFT
567	30/08/2017	30/08/2017		SGST ON CASH HANDLING CHRGS	1.00		2,36,084.77	
568	30/08/2017	30/08/2017		CGST ON CASH HANDLING CHRGS	1.00		2,36,085.77	
569	30/08/2017	30/08/2017		CASH HANDLING CHRGS for 29-08-2017	12.00		2,36,086.77	
570	29/08/2017	29/08/2017	17099	AS PER LIST	1,11,627.00		2,36,098.77	
571	29/08/2017	29/08/2017		BY GTET		2,30,000.00	3,47,725.77	
572	29/08/2017	29/08/2017		Charges for NEFT Customer Payment :SAA47283726	12.00		1,17,725.77	
573	29/08/2017	29/08/2017	17097	NEFT-OW/SAA47283726/GLOBAL ENTERPRISES	62,508.00		1,17,737.77	
574	29/08/2017	29/08/2017		Charges for NEFT Customer Payment :SAA47272877	12.00		1,80,245.77	
575	29/08/2017	29/08/2017	17098	NEFT-OW/SAA47272877/CAPITAL GOODS SKILLS COUN	45,000.00		1,80,257.77	
576	29/08/2017	29/08/2017		LUDHI-CASH DEPOSIT		1,56,977.00	2,25,257.77	
577	29/08/2017	29/08/2017		By Inst.412/ANDHRA/CTS8/SET 4		16,800.00	68,280.77	
578	24/08/2017	24/08/2017		Charges for NEFT Customer Payment :SAA47166922	12.00		51,480.77	
579	24/08/2017	24/08/2017	017094	NEFT-OW/SAA47166922/PREMA NANDA SWAIN	12,000.00		51,492.77	
580	24/08/2017	24/08/2017	17092	ASPER LIST	30,400.00		63,492.77	

Account Statement for Account Number 14261131000892

581	24/08/2017	24/08/2017	17095	ASPER LIST	9,500.00		93,892.77	
582	24/08/2017	24/08/2017		14265015002678		1,00,000.00	1,03,392.77	
583	24/08/2017	24/08/2017	17093	ASPER LIST	26,500.00		3,392.77	
584	24/08/2017	24/08/2017		Charges for NEFT Customer Payment :SAA47167892	12.00		29,892.77	
585	24/08/2017	24/08/2017	017096	NEFT-OW/SAA47167892/BIDWAN ENTERPRISES	8,112.00		29,904.77	
586	24/08/2017	24/08/2017		Chrgs for RTGS Cust Pymnt:ORBCH17236034928	29.00		38,016.77	
587	24/08/2017	24/08/2017	017091	RTGS-OW/ORBCH17236034928/NI RANJAN DASH	2,33,700.00		38,045.77	
588	24/08/2017	24/08/2017		SGST ON CASH HANDLING CHRGS	2.00		2,71,745.77	
589	24/08/2017	24/08/2017		CGST ON CASH HANDLING CHRGS	2.00		2,71,747.77	
590	24/08/2017	24/08/2017		CASH HANDLING CHRGS for 23-08-2017	20.00		2,71,749.77	
591	23/08/2017	23/08/2017		GTET 14265015002678		1,00,000.00	2,71,769.77	
592	23/08/2017	23/08/2017		CASH DEPOSIT		1,20,000.00	1,71,769.77	
593	23/08/2017	23/08/2017		Charges for NEFT Customer Payment :SAA47123014	12.00		51,769.77	
594	23/08/2017	23/08/2017	017089	NEFT-OW/SAA47123014/CESU KED KHURDA	5,106.00		51,781.77	
595	23/08/2017	23/08/2017		Charges for NEFT Customer Payment :SAA47123742	12.00		56,887.77	
596	23/08/2017	23/08/2017	017090	NEFT-OW/SAA47123742/CESUKE D KHURDA	12,465.00		56,899.77	
597	22/08/2017	22/08/2017		NEFT-URBAN LADDER HOME DECOR S		25,505.66	69,364.77	NEFT-CITIN17817582145
598	19/08/2017	19/08/2017		Charges for NEFT Customer Payment :SAA47038946	12.00		43,859.11	
599	19/08/2017	19/08/2017	017087	NEFT-OW/SAA47038946/CAPITAL MARBLE AND GRANIT	27,376.00		43,871.11	
600	19/08/2017	19/08/2017		Charges for NEFT Customer Payment :SAA47038595	12.00		71,247.11	
601	19/08/2017	19/08/2017	017086	NEFT-OW/SAA47038595/MAHEND RA SINGH	34,800.00		71,259.11	
602	19/08/2017	19/08/2017	17088	SURENDRA NAYAK	30,000.00		1,06,059.11	
603	19/08/2017	19/08/2017		Charges for NEFT Customer Payment :SAA47028936	12.00		1,36,059.11	
604	19/08/2017	19/08/2017	017085	NEFT-OW/SAA47028936/NIRANJA N DASH	33,033.00		1,36,071.11	

Account Statement for Account Number 14261131000892

605	19/08/2017	19/08/2017		Charges for NEFT Customer Payment :SAA47030218	12.00		1,69,104.11	
606	19/08/2017	19/08/2017	017084	NEFT-OW/SAA47030218/BABULA L YADAV	18,850.00		1,69,116.11	
607	19/08/2017	19/08/2017		NEFT-URBAN LADDER HOME DECOR S		19,233.00	1,87,966.11	NEFT-CITIN17816718704
608	18/08/2017	18/08/2017	17083	20161131000346	20,000.00		1,68,733.11	
609	18/08/2017	18/08/2017	17077	JASMINE PARIDA	14,400.00		1,88,733.11	Zone Serial [158]
610	18/08/2017	18/08/2017		By Inst.408300/SBI/CTS8/SET		96,139.00	2,03,133.11	
611	17/08/2017	17/08/2017	17082	ASPER LIST	14,850.00		1,06,994.11	
612	17/08/2017	17/08/2017		THANS-CASH DEPOSIT		10,400.00	1,21,844.11	
613	11/08/2017	11/08/2017		Charges for NEFT Customer Payment :SAA46844090	12.00		1,11,444.11	
614	11/08/2017	11/08/2017	017081	NEFT-OW/SAA46844090/BISIKES AN SUNANI	10,000.00		1,11,456.11	
615	11/08/2017	11/08/2017	17078	SALARYJULY17	2,55,740.00		1,21,456.11	
616	11/08/2017	11/08/2017		BY GTET		3,00,000.00	3,77,196.11	
617	11/08/2017	11/08/2017	17079	AS PER LIST	26,831.00		77,196.11	
618	11/08/2017	11/08/2017	17080	BULK NEFT	2,29,731.00		1,04,027.11	
619	09/08/2017	09/08/2017	17076	ASPER LIST	25,22,246.00		3,33,758.11	
620	09/08/2017	09/08/2017		NEFT-AMARJEET SINGH		4,300.00	28,56,004.11	NEFT-1269251920
621	08/08/2017	08/08/2017	17075	ASPER LIST	1,23,915.00		28,51,704.11	
622	08/08/2017	08/08/2017		NEFT-WESTERN REFRIGERATION PVT		25,68,723.00	29,75,619.11	NEFT-6121722066726-1
623	04/08/2017	04/08/2017		NEWDL-By Inst.192031/CANARA/		1,25,000.00	4,06,896.11	
624	04/08/2017	04/08/2017		BULK NEFT RETURN,CHQ 17074		4,000.00	2,81,896.11	
625	03/08/2017	03/08/2017	17074	BULK NEFT	1,08,757.00		2,77,896.11	
626	03/08/2017	03/08/2017		SGST ON CASH HANDLING CHRGS	2.00		3,86,653.11	
627	03/08/2017	03/08/2017		CGST ON CASH HANDLING CHRGS	2.00		3,86,655.11	
628	03/08/2017	03/08/2017		CASH HANDLING CHRGS for 02-08-2017	25.00		3,86,657.11	
629	02/08/2017	02/08/2017		Charges for NEFT Customer Payment :SAA46528261	12.00		3,86,682.11	
630	02/08/2017	02/08/2017	017073	NEFT-OW/SAA46528261/DEBASIS H PUROHIT	75,000.00		3,86,694.11	
631	02/08/2017	02/08/2017		Charges for NEFT Customer Payment :SAA46526233	12.00		4,61,694.11	
632	02/08/2017	02/08/2017	017072	NEFT-OW/SAA46526233/GRAM TARANG EMPLOYABILITY	1,00,000.00		4,61,706.11	
633	02/08/2017	02/08/2017		LUDHI-CASH DEPOSIT		1,71,825.00	5,61,706.11	

Account Statement for Account Number 14261131000892

634	01/08/2017	01/08/2017	17071	AS PER LIST	6,794.00		3,89,881.11	
635	01/08/2017	01/08/2017		04951131001588		2,50,000.00	3,96,675.11	
636	01/08/2017	01/08/2017		Charges for NEFT Customer Payment :SAA46487030	17.00		1,46,675.11	
637	01/08/2017	01/08/2017	017070	NEFT-OW/SAA46487030/GRAM TARANG EMPLOYABILITY	1,50,000.00		1,46,692.11	
638	01/08/2017	01/08/2017	17069	SELF	50,000.00		2,96,692.11	
639	31/07/2017	31/07/2017		Loan Recovery For 14266515002745	9,880.99		3,46,692.11	Loan Recovery
640	31/07/2017	31/07/2017	17068	AS PER REQUEST	2,46,000.00		3,56,573.10	
641	31/07/2017	31/07/2017	17061	SUBHAKANTAPATTANAIK	13,000.00		6,02,573.10	Zone Serial [312]
642	29/07/2017	29/07/2017	17067	AS PER LIST	2,01,000.00		6,15,573.10	
643	29/07/2017	29/07/2017		NEFT-GYANPEETH EDUCATIONAL SOC		46,800.00	8,16,573.10	NEFT-CBINH17210130 970
644	29/07/2017	29/07/2017		IMPSINP2A/721014007927/9 830138280/9059000/INET		20,000.00	7,69,773.10	PARTHA PRATIMROY/gram tarang p
645	28/07/2017	28/07/2017	17066	AS PER LIST	95,385.00		7,49,773.10	
646	28/07/2017	28/07/2017		Charges for NEFT Customer Payment :SAA46384480	12.00		8,45,158.10	
647	28/07/2017	28/07/2017	017063	NEFT-OW/SAA46384480/RAJNEE SH GUPTA	10,000.00		8,45,170.10	
648	28/07/2017	28/07/2017		RSITA-GTET		7,00,000.00	8,55,170.10	
649	28/07/2017	28/07/2017		Charges for NEFT Customer Payment :SAA46382931	12.00		1,55,170.10	NEFT
650	28/07/2017	28/07/2017	017062	NEFT-OW/SAA46382931/ANANTA KUMAR RAY	25,048.00		1,55,182.10	NEFT
651	28/07/2017	28/07/2017		Charges for NEFT Customer Payment :SAA46383115	12.00		1,80,230.10	NEFT
652	28/07/2017	28/07/2017	017065	NEFT-OW/SAA46383115/S K RAKIBUL ISLAM	57,400.00		1,80,242.10	NEFT
653	28/07/2017	28/07/2017		Charges for NEFT Customer Payment :SAA46383296	12.00		2,37,642.10	NEFT
654	28/07/2017	28/07/2017	017064	NEFT-OW/SAA46383296/GRAM TARANG EMPLOYABILITY	60,000.00		2,37,654.10	NEFT
655	27/07/2017	27/07/2017	17060	AS PER LIST	7,800.00		2,97,654.10	
656	26/07/2017	26/07/2017		GHABA-By Inst.192028/CANARA/CTS23 /SET 20		1,50,000.00	3,05,454.10	
657	26/07/2017	26/07/2017		GHABA-spd clg chrgs	177.00		1,55,454.10	
658	25/07/2017	25/07/2017		COIMB-KG CENTURION TRAINING DIVISION SRI KANNAPIRA		28,500.00	1,55,631.10	
659	25/07/2017	25/07/2017	17058	SHREE KRISHNA TRADERS	69,297.00		1,27,131.10	Zone Serial [605]

Account Statement for Account Number 14261131000892

660	24/07/2017	24/07/2017		NEFT-CTTC BBSR		8,050.00	1,96,428.10	NEFT-SBIN217205020258
661	24/07/2017	24/07/2017		BULK NEFT RETURNED ON DT 21.07.2017/CHQ NO 17055		5,682.00	1,88,378.10	
662	24/07/2017	24/07/2017		Charges for NEFT Customer Payment :SAA46223517	12.00		1,82,696.10	
663	24/07/2017	24/07/2017	17057	NEFT-OW/SAA46223517/IRDWSI	31,500.00		1,82,708.10	
664	24/07/2017	24/07/2017		GTETS		50,000.00	2,14,208.10	
665	24/07/2017	24/07/2017	17059	AS PER LIST	22,131.00		1,64,208.10	
666	24/07/2017	24/07/2017	17053	UTKAL AGENCIES	3,179.00		1,86,339.10	Zone Serial [45]
667	21/07/2017	21/07/2017	17055	NEFT UPLD	1,29,728.00		1,89,518.10	
668	21/07/2017	21/07/2017	17056	AS PER LIST	2,00,000.00		3,19,246.10	
669	21/07/2017	21/07/2017		GTETS		70,000.00	5,19,246.10	
670	21/07/2017	21/07/2017		GTETS		50,000.00	4,49,246.10	
671	21/07/2017	21/07/2017	17054	AS PER LIST	1,10,663.00		3,99,246.10	
672	21/07/2017	21/07/2017		By Inst.190900/SBI/CTS8/SET		25,000.00	5,09,909.10	
673	19/07/2017	19/07/2017		NEFT-ODISHA STATE TREASURY WIT		1,97,400.00	4,84,909.10	NEFT-U000000245158486
674	19/07/2017	19/07/2017		Charges for NEFT Customer Payment :SAA46132039	12.00		2,87,509.10	
675	19/07/2017	19/07/2017	17052	NEFT-OW/SAA46132039/KELU CHARAN PRADHAN	50,000.00		2,87,521.10	
676	19/07/2017	19/07/2017		NEFT-FEEDBACK ENERGY DISTRIBUT		55,162.00	3,37,521.10	NEFT-SBIN717200074912
677	18/07/2017	18/07/2017		Charges for NEFT Customer Payment :SAA46101232	12.00		2,82,359.10	
678	18/07/2017	18/07/2017	17051	NEFT-OW/SAA46101232/CESU KED KHURDA	6,422.00		2,82,371.10	
679	18/07/2017	18/07/2017		Charges for NEFT Customer Payment :SAA46100441	12.00		2,88,793.10	
680	18/07/2017	18/07/2017	17050	NEFT-OW/SAA46100441/CESU KED KHURDA	7,927.00		2,88,805.10	
681	17/07/2017	17/07/2017		BY AMT OFNEFT BULK RTN DTD 15.07.17 VIA CHQ 17044		14,875.00	2,96,732.10	
682	17/07/2017	17/07/2017		Charges for NEFT Customer Payment :SAA46056284	12.00		2,81,857.10	
683	17/07/2017	17/07/2017	17048	NEFT-OW/SAA46056284/ANURAG DAS	50,000.00		2,81,869.10	
684	17/07/2017	17/07/2017		Charges for NEFT Customer Payment :SAA46057955	12.00		3,31,869.10	

Account Statement for Account Number 14261131000892

685	17/07/2017	17/07/2017	17047	NEFT- OW/SAA46057955/SRIKANT A KUMAR DASH	21,673.00		3,31,881.10	
686	17/07/2017	17/07/2017		Chrgs for RTGS Cust Pymnt:ORBCH17198045137	29.00		3,53,554.10	
687	17/07/2017	17/07/2017	17049	RTGS- OW/ORBCH17198045137/S USANT KUMAR MOHANTY	4,26,741.00		3,53,583.10	
688	17/07/2017	17/07/2017		BY GTET		3,00,000.00	7,80,324.10	
689	17/07/2017	17/07/2017		By Inst.417023/CITIBANK/CTS8/ SET 14		16,244.00	4,80,324.10	
690	17/07/2017	17/07/2017		By Inst.389/ANDHRA/CTS8/SET 7		72,000.00	4,64,080.10	
691	15/07/2017	15/07/2017	17043	TOSALARYJUNE17	2,07,836.00		3,92,080.10	
692	15/07/2017	15/07/2017		BY GTET		5,00,000.00	5,99,916.10	
693	15/07/2017	15/07/2017	17044	NEFT BULK UPLD	3,10,381.00		99,916.10	
694	15/07/2017	15/07/2017	17045	AS PER LIST	28,650.00		4,10,297.10	
695	15/07/2017	15/07/2017	17046	AS PER LIST	60,116.00		4,38,947.10	
696	14/07/2017	14/07/2017		GTETS		1,30,000.00	4,99,063.10	
697	14/07/2017	14/07/2017	17041	AS PER LIST	1,13,700.00		3,69,063.10	
698	14/07/2017	14/07/2017		Charges for NEFT Customer Payment :SAA45992074	12.00		4,82,763.10	
699	14/07/2017	14/07/2017	17042	NEFT- OW/SAA45992074/MJR SPORTS CONSULTANCIES	54,058.00		4,82,775.10	
700	14/07/2017	14/07/2017		By Inst.417032/CITIBANK/T:CT S8/13-07-20		77,338.00	5,36,833.10	
701	14/07/2017	14/07/2017		By Inst.417324/CITIBANK/T:CT S8/13-07-20		41,630.00	4,59,495.10	
702	14/07/2017	14/07/2017		By Inst.133412/IOB/CTS8/SET		14,000.00	4,17,865.10	
703	14/07/2017	14/07/2017		By Inst.203149/SBI/CTS8/SET		7,000.00	4,03,865.10	
704	13/07/2017	13/07/2017		SGST ON CASH HANDLING CHRGs	4.00		3,96,865.10	
705	13/07/2017	13/07/2017		CGST ON CASH HANDLING CHRGs	4.00		3,96,869.10	
706	13/07/2017	13/07/2017		CASH HANDLING CHRGs for 12-07-2017	42.00		3,96,873.10	
707	12/07/2017	12/07/2017		NEFT-SELCO FOUNDATION		12,824.00	3,96,915.10	NEFT- P1707128402768 4
708	12/07/2017	12/07/2017	17040	CHANDRAKANTA MISHRA	7,200.00		3,84,091.10	
709	12/07/2017	12/07/2017		CASH DEPOSIT		1,50,000.00	3,91,291.10	
710	12/07/2017	12/07/2017		IB-TPT/31300469/From ***1002837/31300469		11,000.00	2,41,291.10	Urban Ladder em
711	11/07/2017	11/07/2017		BULK NEFT RETURNED ON DT 10.07.2017		4,124.00	2,30,291.10	
712	11/07/2017	11/07/2017	17039	AS PER LIST	30,000.00		2,26,167.10	

Account Statement for Account Number 14261131000892

713	11/07/2017	11/07/2017	17038	AS PER LIST	33,535.00		2,56,167.10	
714	11/07/2017	11/07/2017		SGST ON CASH HANDLING CHRGs	4.00		2,89,702.10	
715	11/07/2017	11/07/2017		CGST ON CASH HANDLING CHRGs	4.00		2,89,706.10	
716	11/07/2017	11/07/2017		CASH HANDLING CHRGs for 10-07-2017	49.00		2,89,710.10	
717	10/07/2017	10/07/2017	17026	AS PER LIST	46,968.00		2,89,759.10	
718	10/07/2017	10/07/2017	17034	NEFT UPLD	19,70,354.00		3,36,727.10	
719	10/07/2017	10/07/2017		CASH DEPOSIT		1,90,000.00	23,07,081.10	
720	10/07/2017	10/07/2017		Charges for NEFT Customer Payment :SAA45847700	29.00		21,17,081.10	
721	10/07/2017	10/07/2017	17036	NEFT- OW/SAA45847700/RAJANI RANI MISHRA	5,40,669.00		21,17,110.10	
722	10/07/2017	10/07/2017	17035	AS PER LIST	19,000.00		26,57,779.10	
723	10/07/2017	10/07/2017	17019	NEELAX GROUPS	4,380.00		26,76,779.10	Zone Serial [105]
724	07/07/2017	07/07/2017		NEFT-OIL INDIA LIMITED		1,74,150.00	26,81,159.10	NEFT- KKBK171883535 861
725	07/07/2017	07/07/2017	17033	AS PER LIST	43,142.00		25,07,009.10	
726	07/07/2017	07/07/2017	17027	NEFT UPLD	3,86,776.00		25,50,151.10	
727	07/07/2017	07/07/2017		Chrgs for RTGS Cust Pymnt:ORBCH17188067776	59.00		29,36,927.10	
728	07/07/2017	07/07/2017	17031	RTGS- OW/ORBCH17188067776/G RAM TARANG EMPLOYABILITY	9,00,000.00		29,36,986.10	
729	07/07/2017	07/07/2017		Chrgs for RTGS Cust Pymnt:ORBCH17188068154	30.00		38,36,986.10	
730	07/07/2017	07/07/2017	17032	RTGS- OW/ORBCH17188068154/G RAM TARANG EMPLOYABILITY	2,00,000.00		38,37,016.10	
731	07/07/2017	07/07/2017		Chrgs for RTGS Cust Pymnt:ORBCH17188068407	30.00		40,37,016.10	
732	07/07/2017	07/07/2017	17030	RTGS- OW/ORBCH17188068407/G RAM TARANG EMPLOYABILITY	2,00,000.00		40,37,046.10	
733	07/07/2017	07/07/2017		Charges for NEFT Customer Payment :SAA45784146	12.00		42,37,046.10	
734	07/07/2017	07/07/2017	17029	NEFT- OW/SAA45784146/IMC OF ITI JAMSHEDPUR	50,000.00		42,37,058.10	
735	07/07/2017	07/07/2017		Charges for NEFT Customer Payment :SAA45784358	12.00		42,87,058.10	
736	07/07/2017	07/07/2017	17028	NEFT- OW/SAA45784358/KOLKAT A PRINTING INK	20,473.00		42,87,070.10	

Account Statement for Account Number 14261131000892

737	07/07/2017	07/07/2017		RTGSOIL INDIA LIMITEDKKBKR2201		14,21,631.00	43,07,543.10	RTGSKKBKR220 17070700424201
738	07/07/2017	07/07/2017		By Inst.876511/SBI/CTS8/SET		19,800.00	28,85,912.10	
739	06/07/2017	06/07/2017		RTGSWESTERN REFRIGERATION PVT		26,51,020.00	28,66,112.10	RTGSBOTMH171 87241810
740	06/07/2017	06/07/2017		Chrgs for RTGS Cust Pymnt:ORBCH17187033601	59.00		2,15,092.10	
741	06/07/2017	06/07/2017	17025	RTGS- OW/ORBCH17187033601/G RAM TARANG EMPLOYABILITY	19,00,000.00		2,15,151.10	
742	06/07/2017	06/07/2017		Chrgs for RTGS Cust Pymnt:ORBCH17187033123	59.00		21,15,151.10	
743	06/07/2017	06/07/2017	17024	RTGS- OW/ORBCH17187033123/G RAM TARANG EMPLOYABILITY	20,00,000.00		21,15,210.10	
744	06/07/2017	06/07/2017	17023	AS PER LIST	26,515.00		41,15,210.10	
745	06/07/2017	06/07/2017		14261131001271		39,20,000.00	41,41,725.10	
746	05/07/2017	05/07/2017		Charges for NEFT Customer Payment :SAA45721210	30.00		2,21,725.10	
747	05/07/2017	05/07/2017	17021	NEFT- OW/SAA45721210/GRAM TARANG EMPLOYABILITY	7,00,000.00		2,21,755.10	
748	05/07/2017	05/07/2017		GTETS		6,00,000.00	9,21,755.10	
749	05/07/2017	05/07/2017	17022	AS PER LIST	2,34,192.00		3,21,755.10	
750	05/07/2017	05/07/2017		Charges for NEFT Customer Payment :SAA45719264	12.00		5,55,947.10	
751	05/07/2017	05/07/2017		SERVICE TAX ON CASH HANDLING CHRGS	10.00		5,55,959.10	
752	05/07/2017	05/07/2017		CASH HANDLING CHRGS for 04-07-2017	58.00		5,55,969.10	
753	04/07/2017	04/07/2017		NEFT-RAM SINGH COLLEGE OF ENGI		1,75,000.00	5,56,027.10	NEFT- PUNBH17185171 265
754	04/07/2017	04/07/2017		CASH DEPOSIT		3,00,000.00	3,81,027.10	
755	04/07/2017	04/07/2017	17020	AS PER LIST	34,702.00		81,027.10	
756	01/07/2017	01/07/2017		DHARANIDHAR NAYAK		15,000.00	1,15,729.10	
757	01/07/2017	01/07/2017	17018	AS PER LIST	28,000.00		1,00,729.10	
758	01/07/2017	01/07/2017		Charges for NEFT Customer Payment :SAA45610732	30.00		1,28,729.10	
759	01/07/2017	01/07/2017	17016	NEFT- OW/SAA45610732/GRAM TARANG EMPLOYABILITY	3,00,000.00		1,28,759.10	
760	01/07/2017	01/07/2017		Chrgs for RTGS Cust Pymnt:ORBCH17182087601	29.00		4,28,759.10	
761	01/07/2017	01/07/2017	017015	RTGS- OW/ORBCH17182087601/M ARUTI LIFTS	2,50,000.00		4,28,788.10	

Account Statement for Account Number 14261131000892

762	01/07/2017	01/07/2017	17008	santosh	6,932.00		6,78,788.10	Zone Serial [169]
763	01/07/2017	01/07/2017		SERVICE TAX ON CASH HANDLING CHRGS	11.00		6,85,720.10	
764	01/07/2017	01/07/2017		CASH HANDLING CHRGS for 30-06-2017	60.00		6,85,731.10	
765	30/06/2017	30/06/2017		Loan Recovery For 14266515002745	9,880.58		6,85,791.10	Loan Recovery
766	30/06/2017	30/06/2017		Charges for NEFT Customer Payment :SAA45581926	29.00		6,95,671.68	
767	30/06/2017	30/06/2017	017013	NEFT-OW/SAA45581926/GRAM TARANG EMPLOYABILITY	5,00,000.00		6,95,700.68	
768	30/06/2017	30/06/2017		04951131001588		3,00,000.00	11,95,700.68	
769	30/06/2017	30/06/2017	17014	ASPER LIST	1,18,100.00		8,95,700.68	
770	30/06/2017	30/06/2017		CASH DEPOSIT		2,40,000.00	10,13,800.68	
771	30/06/2017	30/06/2017		By Inst.340/STANDARD/CTS8/S ET 1		25,200.00	7,73,800.68	
772	30/06/2017	30/06/2017		SERVICE TAX ON CASH HANDLING CHRGS	8.00		7,48,600.68	
773	30/06/2017	30/06/2017		CASH HANDLING CHRGS for 29-06-2017	51.00		7,48,608.68	
774	29/06/2017	29/06/2017		Charges for NEFT Customer Payment :SAA45544676	29.00		7,48,659.68	
775	29/06/2017	29/06/2017	017012	NEFT-OW/SAA45544676/GRAM TARANG EMPLOYABILITY	20,00,000.00		7,48,688.68	
776	29/06/2017	29/06/2017		04951131001588		23,00,000.00	27,48,688.68	
777	29/06/2017	29/06/2017		CASH DEPOSIT		2,20,000.00	4,48,688.68	
778	29/06/2017	29/06/2017		NEFT-Mrs. SAGARIKA NANDA		25,000.00	2,28,688.68	NEFT-CBINH17180117 345
779	29/06/2017	29/06/2017	17006	NEW INDIA	6,311.00		2,03,688.68	Zone Serial [572]
780	28/06/2017	28/06/2017		NEFT-DISHA		9,370.00	2,09,999.68	NEFT-SBIN2171798536 02
781	28/06/2017	28/06/2017	17011	ASPER LIST	16,000.00		2,00,629.68	
782	28/06/2017	28/06/2017	17007	nizam	25,215.00		2,16,629.68	Zone Serial [272]
783	28/06/2017	28/06/2017		COIMB-KG CENTURION		37,000.00	2,41,844.68	
784	28/06/2017	28/06/2017		By Inst.1618/ICIBANK/CTS8/S ET 5		61,000.00	2,04,844.68	
785	27/06/2017	27/06/2017		Charges for NEFT Customer Payment :SAA45467936	12.00		1,43,844.68	
786	27/06/2017	27/06/2017	017010	NEFT-OW/SAA45467936/BHAI BHAI SHOP	14,820.00		1,43,856.68	
787	27/06/2017	27/06/2017	17009	AS PER LIST	19,97,464.00		1,58,676.68	
788	27/06/2017	27/06/2017		DHARANIDHAR NAYAK		21,700.00	21,56,140.68	
789	27/06/2017	27/06/2017	17748	RAJDHANI MOTORS	5,800.00		21,34,440.68	Zone Serial [136]

Account Statement for Account Number 14261131000892

790	23/06/2017	23/06/2017		NEFT-ODISHA SKILL DEVELOPMENT		57,330.00	21,40,240.68	NEFT-SBIN817174822988
791	23/06/2017	23/06/2017		NEFT-ODISHA SKILL DEVELOPMENT		68,266.00	20,82,910.68	NEFT-SBIN817174821232
792	23/06/2017	23/06/2017		NEFT-ODISHA SKILL DEVELOPMENT		1,19,952.00	20,14,644.68	NEFT-SBIN817174814501
793	23/06/2017	23/06/2017		NEFT-ODISHA SKILL DEVELOPMENT		64,077.00	18,94,692.68	NEFT-SBIN817174813617
794	23/06/2017	23/06/2017		NEFT-ODISHA SKILL DEVELOPMENT		77,610.00	18,30,615.68	NEFT-SBIN817174812535
795	23/06/2017	23/06/2017		NEFT-ODISHA SKILL DEVELOPMENT		72,796.00	17,53,005.68	NEFT-SBIN817174811348
796	23/06/2017	23/06/2017		NEFT-ODISHA SKILL DEVELOPMENT		1,01,528.00	16,80,209.68	NEFT-SBIN817174795042
797	23/06/2017	23/06/2017	17005	ASPER LIST	46,049.00		15,78,681.68	
798	23/06/2017	23/06/2017		NEFT-ODISHA SKILL DEVELOPMENT		57,330.00	16,24,730.68	NEFT-SBIN817174794209
799	23/06/2017	23/06/2017		NEFT-ODISHA SKILL DEVELOPMENT		1,15,640.00	15,67,400.68	NEFT-SBIN817174810086
800	23/06/2017	23/06/2017		NEFT-ODISHA SKILL DEVELOPMENT		45,570.00	14,51,760.68	NEFT-SBIN817174793484
801	23/06/2017	23/06/2017		NEFT-ODISHA SKILL DEVELOPMENT		62,842.00	14,06,190.68	NEFT-SBIN817174793053
802	23/06/2017	23/06/2017		NEFT-ODISHA SKILL DEVELOPMENT		33,736.00	13,43,348.68	NEFT-SBIN817174788122
803	23/06/2017	23/06/2017		NEFT-ODISHA SKILL DEVELOPMENT		22,050.00	13,09,612.68	NEFT-SBIN817174796257
804	23/06/2017	23/06/2017		NEFT-ODISHA SKILL DEVELOPMENT		35,502.00	12,87,562.68	NEFT-SBIN817174786557
805	23/06/2017	23/06/2017		NEFT-ODISHA SKILL DEVELOPMENT		28,224.00	12,52,060.68	NEFT-SBIN817174786031
806	23/06/2017	23/06/2017		CHENN-CHQ RET CHARGES	58.00		12,23,836.68	OW CHQ RET CHARGES
807	23/06/2017	23/06/2017		REJECT:338308:Funds insufficient	20,000.00		12,23,894.68	Zone Serial [321]
808	23/06/2017	23/06/2017		By Inst.338308/IOB/CTS8/SET		20,000.00	12,43,894.68	
809	22/06/2017	22/06/2017	17742	NIKUNJA CAR FILL	32,865.00		12,23,894.68	Zone Serial [512]
810	22/06/2017	22/06/2017	17743	MAHAPATRA FILLING STAT	16,523.00		12,56,759.68	Zone Serial [247]
811	21/06/2017	21/06/2017		Charges for NEFT Customer Payment :SAA45344465	12.00		12,73,282.68	

Account Statement for Account Number 14261131000892

812	21/06/2017	21/06/2017	017004	NEFT- OW/SAA45344465/SOMANA TH PATNAIK	17,218.00		12,73,294.68	
813	21/06/2017	21/06/2017		Charges for NEFT Customer Payment :SAA45344345	12.00		12,90,512.68	
814	21/06/2017	21/06/2017	017003	NEFT- OW/SAA45344345/WRITUR AJ KAUSHIK	93,800.00		12,90,524.68	
815	21/06/2017	21/06/2017		By Inst.853035/SBI/CTS8/SET		98,700.00	13,84,324.68	
816	21/06/2017	21/06/2017	17001	ASPER LIST	20,50,000.00		12,85,624.68	
817	21/06/2017	21/06/2017		Charges for NEFT Customer Payment :SAA45327257	12.00		33,35,624.68	
818	21/06/2017	21/06/2017	017750	NEFT- OW/SAA45327257/CHAMPA NATH ITC	22,050.00		33,35,636.68	
819	21/06/2017	21/06/2017		Charges for NEFT Customer Payment :SAA45324556	12.00		33,57,686.68	
820	21/06/2017	21/06/2017	017749	NEFT- OW/SAA45324556/PAINTS AND COATINGS SKIL	22,000.00		33,57,698.68	
821	21/06/2017	21/06/2017		Charges for NEFT Customer Payment :SAA45324174	12.00		33,79,698.68	
822	21/06/2017	21/06/2017	017002	NEFT- OW/SAA45324174/AJAY KUMAR ROU	95,191.00		33,79,710.68	
823	21/06/2017	21/06/2017		DHARANIDHAR NAYAK		10,000.00	34,74,901.68	
824	21/06/2017	21/06/2017		NEFT-M S A B CORPORATION		1,00,000.00	34,64,901.68	NEFT- IDIBH171723904 66
825	21/06/2017	21/06/2017		SERVICE TAX ON CASH HANDLING CHRGS	1.00		33,64,901.68	
826	21/06/2017	21/06/2017		CASH HANDLING CHRGS for 20-06-2017	8.00		33,64,902.68	
827	20/06/2017	20/06/2017	17746	ASPER LIST	40,500.00		33,64,910.68	
828	20/06/2017	20/06/2017		Charges for NEFT Customer Payment :SAA45309227	12.00		34,05,410.68	
829	20/06/2017	20/06/2017	17747	NEFT- OW/SAA45309227/JAGABA NDHU PATRA	16,640.00		34,05,422.68	
830	20/06/2017	20/06/2017		Charges for NEFT Customer Payment :SAA45309355	12.00		34,22,062.68	
831	20/06/2017	20/06/2017	17744	NEFT- OW/SAA45309355/CESU KED KHURDA	8,478.00		34,22,074.68	
832	20/06/2017	20/06/2017		Charges for NEFT Customer Payment :SAA45309486	12.00		34,30,552.68	
833	20/06/2017	20/06/2017	17745	NEFT- OW/SAA45309486/CESU KED KHURDA	7,627.00		34,30,564.68	
834	20/06/2017	20/06/2017		CASH DEPOSIT		1,80,000.00	34,38,191.68	

Account Statement for Account Number 14261131000892

835	20/06/2017	20/06/2017		RTGSWESTERN REFRIGERATION PVT		24,63,479.00	32,58,191.68	RTGSBOTMH171 71238323
836	19/06/2017	19/06/2017		Charges for NEFT Customer Payment :SAA45275635	12.00		7,94,712.68	
837	19/06/2017	19/06/2017	017739	NEFT- OW/SAA45275635/RAJEND RA PRASAD NANDA	10,000.00		7,94,724.68	
838	19/06/2017	19/06/2017		Charges for NEFT Customer Payment :SAA45275872	12.00		8,04,724.68	
839	19/06/2017	19/06/2017	017741	NEFT- OW/SAA45275872/PURARA MA PRADHAN	2,300.00		8,04,736.68	
840	19/06/2017	19/06/2017	17740	SK AFJAL	3,280.00		8,07,036.68	
841	19/06/2017	19/06/2017		By Inst.33790/KOTAK/CTS8/SE T 7		3,31,790.00	8,10,316.68	
842	19/06/2017	19/06/2017		By Inst.656361/SBI/CTS8/SET		10,000.00	4,78,526.68	
843	17/06/2017	17/06/2017		CASH DEPOSIT		10,000.00	4,68,526.68	
844	17/06/2017	17/06/2017		SERVICE TAX ON CASH HANDLING CHRGS	5.00		4,58,526.68	
845	17/06/2017	17/06/2017		CASH HANDLING CHRGS for 16-06-2017	32.00		4,58,531.68	
846	16/06/2017	16/06/2017	17737	ASPER LIST	9,125.00		4,58,563.68	
847	16/06/2017	16/06/2017		CASH DEPOSIT		2,10,000.00	4,67,688.68	
848	14/06/2017	14/06/2017		BULK NEFT RETURN ON DATED 13.06.2017		14,875.00	2,57,688.68	
849	14/06/2017	14/06/2017	17736	ISSUE OF DRAFT SCHEME AND COMMN	10,561.00		2,42,813.68	
850	13/06/2017	13/06/2017	16074	SALARYMAY17	2,25,112.00		2,53,374.68	
851	13/06/2017	13/06/2017	16075	ASPER LIST	38,906.00		4,78,486.68	
852	13/06/2017	13/06/2017	16073	BULK NEFT	3,99,679.00		5,17,392.68	
853	13/06/2017	13/06/2017		GTET		7,00,000.00	9,17,071.68	
854	09/06/2017	09/06/2017	17734	ASPER LIST	20,000.00		2,17,071.68	
855	09/06/2017	09/06/2017		Charges for NEFT Customer Payment :SAA45009136	12.00		2,37,071.68	
856	09/06/2017	09/06/2017	17733	NEFT- OW/SAA45009136/ADMINIS TRATOR NESCO UTILI	32,612.00		2,37,083.68	
857	09/06/2017	09/06/2017		Charges for NEFT Customer Payment :SAA45009268	12.00		2,69,695.68	
858	09/06/2017	09/06/2017	017732	NEFT- OW/SAA45009268/SOMNAT H PATNAIK	8,951.00		2,69,707.68	
859	09/06/2017	09/06/2017		Charges for NEFT Customer Payment :SAA45007499	12.00		2,78,658.68	
860	09/06/2017	09/06/2017	017735	NEFT- OW/SAA45007499/ANANTA KUMAR RAY	35,000.00		2,78,670.68	
861	09/06/2017	09/06/2017		Charges for NEFT Customer Payment :SAA44983691	12.00		3,13,670.68	

Account Statement for Account Number 14261131000892

862	09/06/2017	09/06/2017	017731	NEFT-OW/SAA44983691/ANANTA KUMAR RAY	21,100.00		3,13,682.68	
863	09/06/2017	09/06/2017		Charges for NEFT Customer Payment :SAA44984077	12.00		3,34,782.68	
864	09/06/2017	09/06/2017	017728	NEFT-OW/SAA44984077/NIRANJA N DASH	69,188.00		3,34,794.68	
865	09/06/2017	09/06/2017		Charges for NEFT Customer Payment :SAA44985804	12.00		4,03,982.68	
866	09/06/2017	09/06/2017	017729	NEFT-OW/SAA44985804/MS IMC OF ITI JAMSHED PUR	45,000.00		4,03,994.68	
867	09/06/2017	09/06/2017	17724	NEELAX GROUPS	8,130.00		4,48,994.68	Zone Serial [380]
868	08/06/2017	08/06/2017	17730	ASPER LIST	1,10,366.00		4,57,124.68	
869	08/06/2017	08/06/2017		BHOPA-CASH DEPOSIT		26,000.00	5,67,490.68	
870	07/06/2017	07/06/2017	17727	ASPER LIST	1,40,330.00		5,41,490.68	
871	07/06/2017	07/06/2017		Charges for NEFT Customer Payment :SAA44928981	12.00		6,81,820.68	
872	07/06/2017	07/06/2017	017725	NEFT-OW/SAA44928981/MADHUS UDAN DAS	5,000.00		6,81,832.68	
873	07/06/2017	07/06/2017		Charges for NEFT Customer Payment :SAA44928563	29.00		6,86,832.68	
874	07/06/2017	07/06/2017	017726	NEFT-OW/SAA44928563/GRAM TARANG EMPLOYABILITY	20,00,000.00		6,86,861.68	
875	06/06/2017	06/06/2017	17722	ASPER LIST	33,937.00		26,86,861.68	
876	06/06/2017	06/06/2017	17723	BULK NEFT	4,93,548.00		27,20,798.68	
877	06/06/2017	06/06/2017	17721	14261131001271	21,75,828.00		32,14,346.68	
878	06/06/2017	06/06/2017		JAGANNATH INSTITUTE OF TECHNOLOGY/1426101100 0226		50,82,139.00	53,90,174.68	
879	05/06/2017	05/06/2017	17720	AS PER LIST	91,280.00		3,08,035.68	
880	05/06/2017	05/06/2017		Charges for NEFT Customer Payment :SAA44852540	12.00		3,99,315.68	
881	05/06/2017	05/06/2017	17719	NEFT-OW/SAA44852540/MANAS RANJAN SAMAL	6,155.00		3,99,327.68	
882	02/06/2017	02/06/2017		NEFT-PRINCIPAL ADARSH MEDICAL		30,000.00	4,05,482.68	NEFT-PUNBH17153951 430
883	02/06/2017	02/06/2017		04951131001953		2,939.00	3,75,482.68	
884	02/06/2017	02/06/2017		14261131001448		31,745.00	3,72,543.68	
885	02/06/2017	02/06/2017	17716	ASPER LIST	26,179.00		3,40,798.68	
886	02/06/2017	02/06/2017		Charges for NEFT Customer Payment :SAA44775533	12.00		3,66,977.68	
887	02/06/2017	02/06/2017	017717	NEFT-OW/SAA44775533/SUMITR A MOHANTY	77,297.00		3,66,989.68	
888	02/06/2017	02/06/2017	17718	14262041007018	92,200.00		4,44,286.68	

Account Statement for Account Number 14261131000892

889	01/06/2017	01/06/2017		04951131001953		45,050.00	5,36,486.68	
890	01/06/2017	01/06/2017	17715	ASPER LIST	40,193.00		4,91,436.68	
891	01/06/2017	01/06/2017		Charges for NEFT Customer Payment :SAA44738274	12.00		5,31,629.68	
892	01/06/2017	01/06/2017	017714	NEFT-OW/SAA44738274/MS MOHANTY MANPOWER SERVI	13,000.00		5,31,641.68	
893	01/06/2017	01/06/2017		Charges for NEFT Customer Payment :SAA44735811	12.00		5,44,641.68	
894	01/06/2017	01/06/2017	017713	NEFT-OW/SAA44735811/ASHOK KUMAR SINGH	5,800.00		5,44,653.68	
895	01/06/2017	01/06/2017		CASH DEPOSIT		40,000.00	5,50,453.68	
896	31/05/2017	31/05/2017		Loan Recovery For 14266515002745	9,880.43		5,10,453.68	Loan Recovery
897	31/05/2017	31/05/2017		Charges for NEFT Customer Payment :SAA44698543	29.00		5,20,334.11	
898	31/05/2017	31/05/2017	17712	NEFT-OW/SAA44698543/GRAM TARANG EMPLOYABILITY	10,00,000.00		5,20,363.11	
899	31/05/2017	31/05/2017		GTETS		10,50,000.00	15,20,363.11	
900	30/05/2017	30/05/2017	17709	AS PER LIST	21,643.00		4,70,363.11	
901	30/05/2017	30/05/2017		CUTM		55,253.00	4,92,006.11	
902	30/05/2017	30/05/2017		Charges for NEFT Customer Payment :SAA44658988	12.00		4,36,753.11	
903	30/05/2017	30/05/2017	17710	NEFT-OW/SAA44658988/ANANTA KUMAR RAY	8,000.00		4,36,765.11	
904	30/05/2017	30/05/2017		NEFT-AMARJEET SINGH		87,000.00	4,44,765.11	NEFT-1219333483
905	29/05/2017	29/05/2017	17706	AS PER LIST	27,531.00		3,57,765.11	
906	29/05/2017	29/05/2017	17708	SAROJ KU BISWAL	14,000.00		3,85,296.11	
907	29/05/2017	29/05/2017	17707	PURNA CH SWAIN	5,000.00		3,99,296.11	
908	29/05/2017	29/05/2017		CUTM		5,514.00	4,04,296.11	
909	29/05/2017	29/05/2017		Charges for NEFT Customer Payment :SAA44595155	12.00		3,98,782.11	
910	29/05/2017	29/05/2017	17705	NEFT-OW/SAA44595155/LINGARA J PATI	11,047.00		3,98,794.11	
911	29/05/2017	29/05/2017	17704	14261131001448	6,20,517.00		4,09,841.11	
912	29/05/2017	29/05/2017		14261131001677		9,76,374.00	10,30,358.11	
913	26/05/2017	26/05/2017		BULK NEFT RETURN DUE TO WRONG IFSC CODE		2,272.00	53,984.11	
914	26/05/2017	26/05/2017	17702	AS PER LIST	25,253.00		51,712.11	
915	26/05/2017	26/05/2017		CASH DEPOSIT		50,000.00	76,965.11	
916	26/05/2017	26/05/2017		Charges for NEFT Customer Payment :SAA44578507	12.00		26,965.11	

Account Statement for Account Number 14261131000892

917	26/05/2017	26/05/2017	17701	NEFT- OW/SAA44578507/PAL AUTO ELECTRICALS	85,848.00		26,977.11	
918	26/05/2017	26/05/2017	16072	NEFT UPLD	1,27,812.00		1,12,825.11	
919	25/05/2017	25/05/2017	17700	AS PER LIST	83,470.00		2,40,637.11	
920	25/05/2017	25/05/2017		COIMB-K G CENTURION		16,000.00	3,24,107.11	
921	24/05/2017	24/05/2017		Charges for NEFT Customer Payment :SAA44510912	18.00		3,08,107.11	
922	24/05/2017	24/05/2017	16071	NEFT- OW/SAA44510912/MJR SPORTS CONSULTANCIES	1,14,577.00		3,08,125.11	
923	23/05/2017	23/05/2017	17699	AS PER LIST	34,416.00		4,22,702.11	
924	23/05/2017	23/05/2017		RTGSGODREJ CONSUMER PRODUCTS L		3,00,000.00	4,57,118.11	RTGSHSBCR220 17052303739518
925	22/05/2017	22/05/2017		Charges for NEFT Customer Payment :SAA44434021	12.00		1,57,118.11	
926	22/05/2017	22/05/2017	17698	NEFT- OW/SAA44434021/SANGITA BISWAL	12,361.00		1,57,130.11	
927	22/05/2017	22/05/2017	17696	AS PER LIST	1,31,616.00		1,69,491.11	
928	22/05/2017	22/05/2017		Charges for NEFT Customer Payment :SAA44428727	12.00		3,01,107.11	
929	22/05/2017	22/05/2017	17695	NEFT- OW/SAA44428727/GANESH MOHARANA	15,000.00		3,01,119.11	
930	22/05/2017	22/05/2017		Charges for NEFT Customer Payment :SAA44430382	18.00		3,16,119.11	
931	22/05/2017	22/05/2017	17697	NEFT- OW/SAA44430382/HARISH KARA AND ASSOCIATE	1,83,750.00		3,16,137.11	
932	20/05/2017	20/05/2017	17693	AS PER LIST	14,769.00		4,99,887.11	
933	20/05/2017	20/05/2017		Charges for NEFT Customer Payment :SAA44397900	12.00		5,14,656.11	
934	20/05/2017	20/05/2017	17694	NEFT- OW/SAA44397900/AJAY KUMAR	10,462.00		5,14,668.11	
935	19/05/2017	19/05/2017	17692	GTETS	1,00,000.00		5,25,130.11	
936	19/05/2017	19/05/2017		CASH DEPOSIT		1,00,000.00	6,25,130.11	
937	19/05/2017	19/05/2017		Charges for NEFT Customer Payment :SAA44366262	12.00		5,25,130.11	
938	19/05/2017	19/05/2017	17690	NEFT- OW/SAA44366262/CESU KED KHURDA	7,186.00		5,25,142.11	
939	19/05/2017	19/05/2017		Charges for NEFT Customer Payment :SAA44365403	12.00		5,32,328.11	
940	19/05/2017	19/05/2017	17691	NEFT- OW/SAA44365403/CESU KED KHURDA	6,387.00		5,32,340.11	
941	18/05/2017	18/05/2017	17688	AS PER LIST	11,533.00		5,38,727.11	

Account Statement for Account Number 14261131000892

942	18/05/2017	18/05/2017		Charges for NEFT Customer Payment :SAA44331714	12.00		5,50,260.11	
943	18/05/2017	18/05/2017	17689	NEFT-OW/SAA44331714/ANANTA KUMAR RAY	5,000.00		5,50,272.11	
944	17/05/2017	17/05/2017		CHENN-CHQ RET CHARGES	58.00		5,55,272.11	OW CHQ RET CHARGES
945	17/05/2017	17/05/2017		REJECT:553288:Funds insufficient	50,000.00		5,55,330.11	Zone Serial [217]
946	17/05/2017	17/05/2017		GTETS		2,00,000.00	6,05,330.11	
947	17/05/2017	17/05/2017		RTGSSAI SITARAM CONSTRUCTIONSB		2,50,000.00	4,05,330.11	RTGSSBINR5201 7051700048254
948	17/05/2017	17/05/2017	17687	AS PER LIST	64,619.00		1,55,330.11	
949	17/05/2017	17/05/2017		NEFT-G B M C L-PAYMENT TO SUPP		39,085.00	2,19,949.11	NEFT-CITIN177800122 17
950	17/05/2017	17/05/2017		By Inst.553288/BARODA/CTS8/ SET 1		50,000.00	1,80,864.11	
951	17/05/2017	17/05/2017		NEFT-APPAREL MAD HOM FURN SEC		45,000.00	1,30,864.11	NEFT-N1371702954267 14
952	16/05/2017	16/05/2017	17686	AS PER LIST	3,00,778.00		85,864.11	
953	16/05/2017	16/05/2017		CASH DEPOSIT		80,000.00	3,86,642.11	
954	15/05/2017	15/05/2017		DHRUB CHARAN SAHOO		2,555.00	3,06,642.11	
955	15/05/2017	15/05/2017	17685	AS PER LIST	69,676.00		3,04,087.11	
956	12/05/2017	12/05/2017	17683	SALARYAPR17	1,98,764.00		3,73,763.11	
957	12/05/2017	12/05/2017	17682	NEFT BULK UPLD	2,89,515.00		5,72,527.11	
958	12/05/2017	12/05/2017	17684	AS PER LIST	25,648.00		8,62,042.11	
959	12/05/2017	12/05/2017		14265015002678		6,00,000.00	8,87,690.11	
960	12/05/2017	12/05/2017		Charges for NEFT Customer Payment :SAA44165139	12.00		2,87,690.11	
961	12/05/2017	12/05/2017	17681	NEFT-OW/SAA44165139/KARTIKA KUMAR SAHOO	5,499.00		2,87,702.11	
962	12/05/2017	12/05/2017		LUDHI-By Inst.149996/ICICIBANK/		62,856.00	2,93,201.11	
963	11/05/2017	11/05/2017	17678	AS PER LIST	3,55,000.00		2,30,345.11	
964	11/05/2017	11/05/2017		NEFT-GRAM TARANG EMPLOYABILITY		4,00,000.00	5,85,345.11	NEFT-AXSK171310018 425
965	11/05/2017	11/05/2017		Charges for NEFT Customer Payment :SAA44119633	12.00		1,85,345.11	
966	11/05/2017	11/05/2017	17679	NEFT-OW/SAA44119633/RAJNAN DAN SINGH	15,000.00		1,85,357.11	
967	11/05/2017	11/05/2017		Charges for NEFT Customer Payment :SAA44119338	12.00		2,00,357.11	
968	11/05/2017	11/05/2017	17680	NEFT-OW/SAA44119338/BALIJEET LOHIA	7,500.00		2,00,369.11	
969	11/05/2017	11/05/2017		CASH DEPOSIT		90,000.00	2,07,869.11	

Account Statement for Account Number 14261131000892

970	10/05/2017	10/05/2017		Charges for NEFT Customer Payment :SAA44079751	12.00		1,17,869.11	
971	10/05/2017	10/05/2017	17671	NEFT-OW/SAA44079751/M PREM SRIDHAR	22,500.00		1,17,881.11	
972	10/05/2017	10/05/2017		Charges for NEFT Customer Payment :SAA44080884	12.00		1,40,381.11	
973	10/05/2017	10/05/2017	17672	NEFT-OW/SAA44080884/ANANTA KUMAR RAY	7,500.00		1,40,393.11	
974	10/05/2017	10/05/2017		Charges for NEFT Customer Payment :SAA44080565	12.00		1,47,893.11	
975	10/05/2017	10/05/2017	17675	NEFT-OW/SAA44080565/DINESH KUMAR SINGH	50,000.00		1,47,905.11	
976	10/05/2017	10/05/2017		Charges for NEFT Customer Payment :SAA44080759	12.00		1,97,905.11	
977	10/05/2017	10/05/2017	17673	NEFT-OW/SAA44080759/ANUARA G	50,000.00		1,97,917.11	
978	10/05/2017	10/05/2017		Charges for NEFT Customer Payment :SAA44080367	12.00		2,47,917.11	
979	10/05/2017	10/05/2017	17674	NEFT-OW/SAA44080367/NEHUL PATEL	50,000.00		2,47,929.11	
980	10/05/2017	10/05/2017		Charges for NEFT Customer Payment :SAA44080125	12.00		2,97,929.11	
981	10/05/2017	10/05/2017	17677	NEFT-OW/SAA44080125/SHASHIK ANT MORE	50,000.00		2,97,941.11	
982	10/05/2017	10/05/2017		Charges for NEFT Customer Payment :SAA44079984	12.00		3,47,941.11	
983	10/05/2017	10/05/2017	17676	NEFT-OW/SAA44079984/SAURAB H TIWARI	50,000.00		3,47,953.11	
984	10/05/2017	10/05/2017		Charges for NEFT Customer Payment :SAA44074095	18.00		3,97,953.11	
985	10/05/2017	10/05/2017	17668	NEFT-OW/SAA44074095/AJAY KU DWIBEDI	1,69,386.00		3,97,971.11	
986	10/05/2017	10/05/2017		Charges for NEFT Customer Payment :SAA44072886	12.00		5,67,357.11	
987	10/05/2017	10/05/2017	17667	NEFT-OW/SAA44072886/RAJAT KUMAR MOHAPATRA	6,875.00		5,67,369.11	
988	10/05/2017	10/05/2017		Chrgs for RTGS Cust Pymnt:ORBCH17130059797	57.00		5,74,244.11	
989	10/05/2017	10/05/2017	17669	RTGS-OW/ORBCH17130059797/G RAM TARANG EMPLOYABILITY	10,00,000.00		5,74,301.11	

Account Statement for Account Number 14261131000892

990	10/05/2017	10/05/2017	17670	AS PER LIST	22,834.00		15,74,301.11	
991	09/05/2017	09/05/2017		NEFT-RETURN- X090517142615303		1,604.00	15,97,135.11	SBINP171293152 82-R03-
992	09/05/2017	09/05/2017	17666	AS PER LIST	12,30,000.00		15,95,531.11	
993	09/05/2017	09/05/2017	17665	NEFT BULK	23,504.00		28,25,531.11	
994	09/05/2017	09/05/2017	17664	AS PER LIST	75,000.00		28,49,035.11	
995	09/05/2017	09/05/2017		RTGSWESTERN REFRIGERATION PVT		25,84,664.00	29,24,035.11	RTGSBOTMH171 29231665
996	09/05/2017	09/05/2017		NEFT-RETURN- X080517142620977		11,255.00	3,39,371.11	SBINP171282952 65-R11-
997	09/05/2017	09/05/2017		NEFT-RETURN- X080517142620993		5,667.00	3,28,116.11	UCBAG17128019 175-R03-
998	09/05/2017	09/05/2017		NEFT-RETURN- X080517142621091		5,271.00	3,22,449.11	SBINP171282951 93-R03-
999	08/05/2017	08/05/2017		NEFT-RETURN- X080517142621008		9,041.00	3,17,178.11	RETD170508649 906-R03-
1000	08/05/2017	08/05/2017	17663	BULK NEFT	85,668.00		3,08,137.11	
1001	08/05/2017	08/05/2017	17662	BULK NEFT	8,13,658.00		3,93,805.11	
1002	08/05/2017	08/05/2017	17661	AS PER LIST	50,778.00		12,07,463.11	
1003	08/05/2017	08/05/2017		BY 14265015002678		8,00,000.00	12,58,241.11	
1004	08/05/2017	08/05/2017		Charges for NEFT Customer Payment :SAA44014603	12.00		4,58,241.11	NEFT
1005	08/05/2017	08/05/2017	017660	NEFT- OW/SAA44014603/ANANTA KUMAR RAY	5,000.00		4,58,253.11	NEFT
1006	08/05/2017	08/05/2017		Charges for NEFT Customer Payment :SAA44015341	12.00		4,63,253.11	NEFT
1007	08/05/2017	08/05/2017	017659	NEFT- OW/SAA44015341/MADAN RAM PORTE	10,000.00		4,63,265.11	NEFT
1008	08/05/2017	08/05/2017	17657	TRF AS PER LIST	2,04,000.00		4,73,265.11	
1009	08/05/2017	08/05/2017		Charges for NEFT Customer Payment :SAA44007005	12.00		6,77,265.11	NEFT
1010	08/05/2017	08/05/2017	017658	NEFT-OW/SAA44007005/MS IMC OF ITI JAMSHEDPUR	45,000.00		6,77,277.11	NEFT
1011	08/05/2017	08/05/2017		MUMBA-CHQ RET CHARGES	173.00		7,22,277.11	IW CHQ RET CHARGES
1012	06/05/2017	06/05/2017		NEFT-GRAMTARANG EMPLOYABI		5,00,000.00	7,22,450.11	NEFT- P1705066713074 1
1013	06/05/2017	06/05/2017		GTETS		2,00,000.00	2,22,450.11	
1014	06/05/2017	06/05/2017	17656	AS PER LIST	2,18,968.00		22,450.11	
1015	06/05/2017	06/05/2017		Charges for NEFT Customer Payment :SAA43966774	12.00		2,41,418.11	
1016	06/05/2017	06/05/2017	17655	NEFT- OW/SAA43966774/TRIP SHOPPERS COM	6,180.00		2,41,430.11	
1017	05/05/2017	05/05/2017	17654	AS PER LIST	5,738.00		2,47,610.11	
1018	05/05/2017	05/05/2017		NEFT-BALAJI TRADING		7,000.00	2,53,348.11	NEFT- P1705054324701 4

Account Statement for Account Number 14261131000892

1019	05/05/2017	05/05/2017	17651	AS PER LIST	85,522.00		2,46,348.11	
1020	05/05/2017	05/05/2017		GTETS		2,50,000.00	3,31,870.11	
1021	04/05/2017	04/05/2017		NEFT-SELCO FOUNDATION		12,359.00	81,870.11	NEFT- P1705045263867 8
1022	04/05/2017	04/05/2017	17653	AS PER LIST	28,000.00		69,511.11	
1023	04/05/2017	04/05/2017		CASH DEPOSIT		50,000.00	97,511.11	
1024	04/05/2017	04/05/2017		Charges for NEFT Customer Payment :SAA43885334	12.00		47,511.11	
1025	04/05/2017	04/05/2017	17652	NEFT- OW/SAA43885334/POWER SECTOR SKILL COUNCI	25,000.00		47,523.11	
1026	03/05/2017	03/05/2017	15375	AS PER LIST	21,000.00		72,523.11	
1027	03/05/2017	03/05/2017	15374	AJAY KU ROUT	20,000.00		93,523.11	
1028	02/05/2017	02/05/2017	16070	AS PER LIST	30,870.00		1,13,523.11	
1029	01/05/2017	01/05/2017		Charges for NEFT Customer Payment :SAA43766927	12.00		1,44,393.11	
1030	01/05/2017	01/05/2017	16069	NEFT- OW/SAA43766927/LINGARA J PATI	10,000.00		1,44,405.11	
1031	01/05/2017	01/05/2017		NEFT-MVSN		8,250.00	1,54,405.11	NEFT- SBIN8171212410 04
1032	01/05/2017	01/05/2017	16068	AS PER LIST	13,000.00		1,46,155.11	
1033	01/05/2017	01/05/2017	16061	SHREE RAGHUNATH STORE	11,190.00		1,59,155.11	Zone Serial [104]
1034	29/04/2017	30/04/2017		Loan Recovery For 14266515002745	9,879.67		1,70,345.11	Loan Recovery
1035	29/04/2017	29/04/2017	16065	AS PER LIST	2,50,995.00		1,80,224.78	
1036	29/04/2017	29/04/2017	16067	AMLAN BARIK	8,000.00		4,31,219.78	
1037	29/04/2017	29/04/2017		Charges for NEFT Customer Payment :SAA43738499	12.00		4,39,219.78	
1038	29/04/2017	29/04/2017	16066	NEFT- OW/SAA43738499/GANESH MAHARANA	7,000.00		4,39,231.78	
1039	29/04/2017	29/04/2017	16064	AS PER LIST	1,05,066.00		4,46,231.78	
1040	28/04/2017	28/04/2017	16063	AS PER LIST	17,757.00		5,51,297.78	
1041	28/04/2017	28/04/2017		Charges for NEFT Customer Payment :SAA43702533	12.00		5,69,054.78	
1042	28/04/2017	28/04/2017	016062	NEFT- OW/SAA43702533/NIRANJA N DASH	19,950.00		5,69,066.78	
1043	28/04/2017	28/04/2017	16049	NEELAX GROUPS	3,885.00		5,89,016.78	Zone Serial [376]
1044	27/04/2017	27/04/2017	16060	AS PER LIST	13,530.00		5,92,901.78	
1045	27/04/2017	27/04/2017		By Inst.302274/ANDHRA/CTS8/ SET 2		12,000.00	6,06,431.78	
1046	27/04/2017	27/04/2017		By Inst.302275/ANDHRA/CTS8/ SET 2		13,000.00	5,94,431.78	
1047	27/04/2017	27/04/2017	16054	rab	63,359.00		5,81,431.78	Zone Serial [205]

Account Statement for Account Number 14261131000892

1048	27/04/2017	27/04/2017	16053	MANGALA ENTERPRISERS	53,704.00		6,44,790.78	Zone Serial [137]
1049	26/04/2017	26/04/2017	16058	AS PER LIST	75,020.00		6,98,494.78	
1050	26/04/2017	26/04/2017		Charges for NEFT Customer Payment :SAA43621854	12.00		7,73,514.78	
1051	26/04/2017	26/04/2017	16057	NEFT-OW/SAA43621854/CENTRAL TOOL ROOM AND TRA	5,000.00		7,73,526.78	
1052	26/04/2017	26/04/2017		Charges for NEFT Customer Payment :SAA43621285	12.00		7,78,526.78	
1053	26/04/2017	26/04/2017	16059	NEFT-OW/SAA43621285/ALOK PARASHAR	70,081.00		7,78,538.78	
1054	25/04/2017	25/04/2017		NEFT-Mrs. ANITA SINGH		58,689.00	8,48,619.78	NEFT-CBINH17115151591
1055	25/04/2017	25/04/2017	16056	AS PER LIST	23,563.00		7,89,930.78	
1056	25/04/2017	25/04/2017		JITM.CSREM TRUST.		85,719.00	8,13,493.78	
1057	25/04/2017	25/04/2017		NEFT-DEEPAK KUMAR SAHOO		50,000.00	7,27,774.78	NEFT-SBIN317115591641
1058	25/04/2017	25/04/2017		GTETS		6,00,000.00	6,77,774.78	
1059	25/04/2017	25/04/2017		Chrgs for RTGS Cust Pymnt:ORBCH17115073026	57.00		77,774.78	
1060	25/04/2017	25/04/2017	16055	RTGS-OW/ORBCH17115073026/G RAM TARANG EMPLOYABILITY	6,00,000.00		77,831.78	
1061	24/04/2017	24/04/2017	16051	AS PER LIST	24,560.00		6,77,831.78	
1062	24/04/2017	24/04/2017		Charges for NEFT Customer Payment :SAA43548115	12.00		7,02,391.78	
1063	24/04/2017	24/04/2017	016050	NEFT-OW/SAA43548115/AJAY KUMAR ROUT	62,688.00		7,02,403.78	
1064	24/04/2017	24/04/2017		Charges for NEFT Customer Payment :SAA43540371	12.00		7,65,091.78	
1065	24/04/2017	24/04/2017	016052	NEFT-OW/SAA43540371/ANANTA KUMAR RAY	5,000.00		7,65,103.78	
1066	21/04/2017	21/04/2017		COIMB-KG CENTURION		21,500.00	7,70,103.78	
1067	21/04/2017	21/04/2017		Charges for NEFT Customer Payment :SAA43502213	12.00		7,48,603.78	
1068	21/04/2017	21/04/2017	16045	NEFT-OW/SAA43502213/CESU KED KHURDA	4,105.00		7,48,615.78	
1069	21/04/2017	21/04/2017	16044	AS PER LIST	15,070.00		7,52,720.78	
1070	21/04/2017	21/04/2017		Charges for NEFT Customer Payment :SAA43500105	12.00		7,67,790.78	
1071	21/04/2017	21/04/2017	16047	NEFT-OW/SAA43500105/NIRANJAN DASH	55,868.00		7,67,802.78	

Account Statement for Account Number 14261131000892

1072	21/04/2017	21/04/2017		Charges for NEFT Customer Payment :SAA43500305	12.00		8,23,670.78	
1073	21/04/2017	21/04/2017	16048	NEFT-OW/SAA43500305/ITISHRE E SAHOO	3,500.00		8,23,682.78	
1074	21/04/2017	21/04/2017		Charges for NEFT Customer Payment :SAA43500636	12.00		8,27,182.78	
1075	21/04/2017	21/04/2017	16046	NEFT-OW/SAA43500636/CESU KED KHURDA	14,546.00		8,27,194.78	
1076	20/04/2017	20/04/2017		BY GTET		6,00,000.00	8,41,740.78	
1077	20/04/2017	20/04/2017	16041	AS PER LIST	55,470.00		2,41,740.78	
1078	20/04/2017	20/04/2017		Charges for NEFT Customer Payment :SAA43459500	12.00		2,97,210.78	
1079	20/04/2017	20/04/2017	16039	NEFT-OW/SAA43459500/NIRANJA N DASH	46,377.00		2,97,222.78	
1080	20/04/2017	20/04/2017		REJECT:419906:Present in proper zone	6,700.00		3,43,599.78	Zone Serial [410]
1081	20/04/2017	20/04/2017		Charges for NEFT Customer Payment :SAA43459215	12.00		3,50,299.78	
1082	20/04/2017	20/04/2017	16040	NEFT-OW/SAA43459215/ASTRON AUTS SERVICES PVT L	17,360.00		3,50,311.78	
1083	20/04/2017	20/04/2017		Charges for NEFT Customer Payment :SAA43458913	18.00		3,67,671.78	
1084	20/04/2017	20/04/2017	16043	NEFT-OW/SAA43458913/AJAY KU DWIBEDI	1,07,772.00		3,67,689.78	
1085	20/04/2017	20/04/2017		Chrgs for RTGS Cust Pymnt:ORBCH17110047324	57.00		4,75,461.78	
1086	20/04/2017	20/04/2017	016037	RTGS-OW/ORBCH17110047324/G RAM TARANG EMPLOYABILITY	20,00,000.00		4,75,518.78	
1087	20/04/2017	20/04/2017		Chrgs for RTGS Cust Pymnt:ORBCH17110046098	57.00		24,75,518.78	
1088	20/04/2017	20/04/2017	16038	RTGS-OW/ORBCH17110046098/G RAM TARANG EMPLOYABILITY	20,00,000.00		24,75,575.78	
1089	20/04/2017	20/04/2017		By Inst.237613/SBI/CTS8/SET		5,900.00	44,75,575.78	
1090	20/04/2017	20/04/2017		By Inst.419906/SBI/CTS8/SET		6,700.00	44,69,675.78	
1091	20/04/2017	20/04/2017		NEFT-G B M C L-PAYMENT TO SUPP		16,841.00	44,62,975.78	NEFT-CITIN177696969 81
1092	20/04/2017	20/04/2017	6879	SANJAY KUMAR MAURYA	1,016.00		44,46,134.78	Zone Serial [539]
1093	19/04/2017	19/04/2017	16036	AS PER LIST	31,864.00		44,47,150.78	

Account Statement for Account Number 14261131000892

1094	19/04/2017	19/04/2017		NEFT-NEW INDIA ASSURANCE CO LT		26,800.00	44,79,014.78	NEFT-AXTB171093116 228
1095	19/04/2017	19/04/2017	16035	AS PER LIST	19,000.00		44,52,214.78	
1096	18/04/2017	18/04/2017	16034	AS PER LIST	25,694.00		44,71,214.78	
1097	18/04/2017	18/04/2017		CASH DEPOSIT		80,000.00	44,96,908.78	
1098	18/04/2017	18/04/2017	6870	RANKIT.	6,625.00		44,16,908.78	Zone Serial [671]
1099	18/04/2017	18/04/2017		JAMSH-By Inst.789023/ALLAHABAD/CT S1/SET 18		26,69,932.00	44,23,533.78	
1100	17/04/2017	17/04/2017		NEFT-DISHA		3,00,000.00	17,53,601.78	NEFT-SBIN8171073361 51
1101	17/04/2017	17/04/2017		NEFT-DISHA		2,23,750.00	14,53,601.78	NEFT-SBIN8171073369 04
1102	17/04/2017	17/04/2017	16033	AS PER LIST	14,240.00		12,29,851.78	
1103	17/04/2017	17/04/2017		By Inst.302195/ANDHRA/CTS8/ SET 11		2,000.00	12,44,091.78	
1104	15/04/2017	15/04/2017	16029	AS PER LIST	1,46,272.00		12,42,091.78	
1105	15/04/2017	15/04/2017	16031	RABI NARAYAN SAHOO	10,000.00		13,88,363.78	
1106	15/04/2017	15/04/2017		Charges for NEFT Customer Payment :SAA43308272	12.00		13,98,363.78	
1107	15/04/2017	15/04/2017	016028	NEFT-OW/SAA43308272/SATYAB RATA PARIDA	19,372.00		13,98,375.78	
1108	15/04/2017	15/04/2017		Charges for NEFT Customer Payment :SAA43307448	12.00		14,17,747.78	
1109	15/04/2017	15/04/2017	16030	NEFT-OW/SAA43307448/AJAY KUMAR ROUT	15,291.00		14,17,759.78	
1110	15/04/2017	15/04/2017	16027	AS PER LIST	13,555.00		14,33,050.78	
1111	13/04/2017	13/04/2017		DEBENDRA KU SAHOO		2,000.00	14,46,605.78	
1112	13/04/2017	13/04/2017		Charges for NEFT Customer Payment :SAA43265750	12.00		14,44,605.78	NEFT
1113	13/04/2017	13/04/2017	016025	NEFT-OW/SAA43265750/SUNIL KUMAR	9,373.00		14,44,617.78	NEFT
1114	13/04/2017	13/04/2017		Charges for NEFT Customer Payment :SAA43264896	29.00		14,53,990.78	NEFT
1115	13/04/2017	13/04/2017	016026	NEFT-OW/SAA43264896/NIRANJA N DASH	3,87,337.00		14,54,019.78	NEFT
1116	13/04/2017	13/04/2017		NEFT-RETURN-SAA43242833		1,793.00	18,41,356.78	CBINH17103900 712-R01-
1117	13/04/2017	13/04/2017		Charges for NEFT Customer Payment :SAA43244261	12.00		18,39,563.78	
1118	13/04/2017	13/04/2017	16023	NEFT-OW/SAA43244261/SUDARS AN MAHAPATRA	2,100.00		18,39,575.78	
1119	13/04/2017	13/04/2017	16024	AS PER LIST	18,489.00		18,41,675.78	

Account Statement for Account Number 14261131000892

1120	13/04/2017	13/04/2017	16022	NEFT- OW/SAA43242833/OMM SAI SAHA AND ASSOCIAT	1,793.00		18,60,164.78	
1121	13/04/2017	13/04/2017	16020	NEFT BULK UPLD	33,611.00		18,61,957.78	
1122	13/04/2017	13/04/2017		BY GTET		9,50,000.00	18,95,568.78	
1123	13/04/2017	13/04/2017		SERVICE TAX ON CASH HANDLING CHRGS	11.00		9,45,568.78	
1124	13/04/2017	13/04/2017		CASH HANDLING CHRGS for 12-04-2017	70.00		9,45,579.78	
1125	12/04/2017	12/04/2017	16019	AS PER LIST	40,713.00		9,45,649.78	
1126	12/04/2017	12/04/2017	16021	AS PER LIST	24,128.00		9,86,362.78	
1127	12/04/2017	12/04/2017		CASH DEPOSIT		1,70,000.00	10,10,490.78	
1128	12/04/2017	12/04/2017		BY GTET		2,00,000.00	8,40,490.78	
1129	12/04/2017	12/04/2017	16017	ASPER LIST	6,50,500.00		6,40,490.78	
1130	12/04/2017	12/04/2017		Chrgs for RTGS Cust Pymnt:ORBCH17102098172	57.00		12,90,990.78	
1131	12/04/2017	12/04/2017	016018	RTGS- OW/ORBCH17102098172/G RAM TARANG EMPLOYABILITY	10,00,000.00		12,91,047.78	
1132	12/04/2017	12/04/2017		By Inst.302194/ANDHRA/CTS8/ SET 9		3,000.00	22,91,047.78	
1133	12/04/2017	12/04/2017		By Inst.302193/ANDHRA/CTS8/ SET 9		24,000.00	22,88,047.78	
1134	12/04/2017	12/04/2017		By Inst.302192/ANDHRA/CTS8/ SET 9		3,000.00	22,64,047.78	
1135	12/04/2017	12/04/2017		By Inst.205027/UCO/CTS8/SET		24,000.00	22,61,047.78	
1136	12/04/2017	12/04/2017		By Inst.832935/ODISHA/CTS8/S ET 7		30,000.00	22,37,047.78	
1137	12/04/2017	12/04/2017		Charges for NEFT Customer Payment :SAA43211099	12.00		22,07,047.78	
1138	12/04/2017	12/04/2017	016016	NEFT- OW/SAA43211099/MUKESH ARYA	16,510.00		22,07,059.78	
1139	11/04/2017	11/04/2017	15990	AS PER LIST	1,48,685.00		22,23,569.78	
1140	11/04/2017	11/04/2017	15991	NEFT BULK UPLD	2,02,160.00		23,72,254.78	
1141	11/04/2017	11/04/2017		Charges for NEFT Customer Payment :SAA43180581	29.00		25,74,414.78	
1142	11/04/2017	11/04/2017	16015	NEFT- OW/SAA43180581/GRAM TARANG EMPLOYABILITY	6,00,000.00		25,74,443.78	
1143	11/04/2017	11/04/2017	16014	AS PER LIST	29,230.00		31,74,443.78	
1144	11/04/2017	11/04/2017	15989	SHIRDI SAI CATERING SERVICE AND FOOD PROCESSOR	33,696.00		32,03,673.78	
1145	10/04/2017	10/04/2017		NEFT-GRAMTARANG EMPLOYABI		2,00,000.00	32,37,369.78	NEFT- P1704104424050 1
1146	10/04/2017	10/04/2017	16004	AS PER LIST	47,075.00		30,37,369.78	

Account Statement for Account Number 14261131000892

1147	10/04/2017	10/04/2017		BY GTET		1,00,000.00	30,84,444.78	
1148	10/04/2017	10/04/2017	16012	AS PER LIST	1,07,195.00		29,84,444.78	
1149	10/04/2017	10/04/2017		Charges for NEFT Customer Payment :SAA43140365	12.00		30,91,639.78	
1150	10/04/2017	10/04/2017	16008	NEFT-OW/SAA43140365/TEMBUR U CHINARAO	10,721.00		30,91,651.78	
1151	10/04/2017	10/04/2017		Charges for NEFT Customer Payment :SAA43127924	12.00		31,02,372.78	
1152	10/04/2017	10/04/2017	16010	NEFT-OW/SAA43127924/CREATIVE INTERIORS	27,540.00		31,02,384.78	
1153	10/04/2017	10/04/2017		Charges for NEFT Customer Payment :SAA43128867	12.00		31,29,924.78	
1154	10/04/2017	10/04/2017	16009	NEFT-OW/SAA43128867/MS IMC OF ITI JAMSHEDPUR	45,000.00		31,29,936.78	
1155	10/04/2017	10/04/2017		Charges for NEFT Customer Payment :SAA43127447	18.00		31,74,936.78	
1156	10/04/2017	10/04/2017	16011	NEFT-OW/SAA43127447/TOPCLASS SECURITY AND ALL	1,41,270.00		31,74,954.78	
1157	10/04/2017	10/04/2017		RTGSWESTERN REFRIGERATION PVT		28,87,780.00	33,16,224.78	RTGSBOTMH17100226923
1158	10/04/2017	10/04/2017	15987	AJITESH PATTNAIK	12,302.00		4,28,444.78	
1159	10/04/2017	10/04/2017	16002	SUDARSHAN MOHAPA	1,30,060.00		4,40,746.78	Zone Serial [191]
1160	10/04/2017	10/04/2017		NEFT-RANJANRANA		805.00	5,70,806.78	NEFT-PNBH170974980219
1161	10/04/2017	10/04/2017		NEFT-RETURN-X070417142619954		5,096.00	5,70,001.78	SBINP17097853051-R11-
1162	07/04/2017	07/04/2017	16006	ASPER	27,000.00		5,64,905.78	
1163	07/04/2017	07/04/2017		14265015002678		5,50,000.00	5,91,905.78	
1164	07/04/2017	07/04/2017	16005	BULK NEFT AS PER ATTACHMENT	4,99,544.00		41,905.78	
1165	07/04/2017	07/04/2017		Charges for NEFT Customer Payment :SAA43080272	12.00		5,41,449.78	
1166	07/04/2017	07/04/2017	016007	NEFT-OW/SAA43080272/TEMBUR U CHINARAO	5,000.00		5,41,461.78	
1167	07/04/2017	07/04/2017	15982	CENTURION UNIVERSITY OF T	78,408.00		5,46,461.78	Zone Serial [387]
1168	06/04/2017	06/04/2017	16003	ASPER	35,000.00		6,24,869.78	
1169	06/04/2017	06/04/2017	15986	AMLAN BARIK	30,000.00		6,59,869.78	
1170	05/04/2017	05/04/2017		Charges for NEFT Customer Payment :SAA42994141	12.00		6,89,869.78	
1171	05/04/2017	05/04/2017	015999	NEFT-OW/SAA42994141/GUNANI DHI DAS	25,000.00		6,89,881.78	

Account Statement for Account Number 14261131000892

1172	05/04/2017	05/04/2017		Charges for NEFT Customer Payment :SAA42995505	29.00		7,14,881.78	
1173	05/04/2017	05/04/2017	015998	NEFT-OW/SAA42995505/GTETS PVT LTD	10,00,000.00		7,14,910.78	
1174	05/04/2017	05/04/2017	16001	NEFT UPLD	30,856.00		17,14,910.78	
1175	05/04/2017	05/04/2017		Charges for NEFT Customer Payment :SAA42992990	12.00		17,45,766.78	
1176	05/04/2017	05/04/2017	015983	NEFT-OW/SAA42992990/ASHISH GUPTA	9,356.00		17,45,778.78	
1177	05/04/2017	05/04/2017		Charges for NEFT Customer Payment :SAA42992522	12.00		17,55,134.78	
1178	05/04/2017	05/04/2017	015984	NEFT-OW/SAA42992522/ALOK PARASHAR	19,003.00		17,55,146.78	
1179	05/04/2017	05/04/2017	16000	AS PER LIST	22,500.00		17,74,149.78	
1180	04/04/2017	04/04/2017		RTGSOIL INDIA LIMITEDKKBKR2201		3,48,300.00	17,96,649.78	RTGSKKBKR22017040400418354
1181	03/04/2017	03/04/2017		NEFT-DISHA		4,00,000.00	14,48,349.78	NEFT-SBIN917093088361
1182	03/04/2017	03/04/2017		NEFT-DISHA		1,00,000.00	10,48,349.78	NEFT-SBIN917093089000
1183	03/04/2017	03/04/2017		Charges for NEFT Customer Payment :SAA42918153	12.00		9,48,349.78	
1184	03/04/2017	03/04/2017	015995	NEFT-OW/SAA42918153/STALIN MALLIK	4,935.00		9,48,361.78	
1185	03/04/2017	03/04/2017	15994	AS PER LIST	19,935.00		9,53,296.78	
1186	03/04/2017	03/04/2017		Charges for NEFT Customer Payment :SAA42920877	12.00		9,73,231.78	
1187	03/04/2017	03/04/2017	15997	NEFT-OW/SAA42920877/BRIM INDUSTRIES	50,000.00		9,73,243.78	
1188	03/04/2017	03/04/2017		Charges for NEFT Customer Payment :SAA42921362	12.00		10,23,243.78	
1189	03/04/2017	03/04/2017	015993	NEFT-OW/SAA42921362/MUKESH ARYA	15,000.00		10,23,255.78	
1190	03/04/2017	03/04/2017	15992	AS PER LIST	29,000.00		10,38,255.78	
1191	03/04/2017	03/04/2017		Charges for NEFT Customer Payment :SAA42915132	12.00		10,67,255.78	
1192	03/04/2017	03/04/2017	015996	NEFT-OW/SAA42915132/SUDARS AN MAHAPATRA	50,000.00		10,67,267.78	
1193	03/04/2017	03/04/2017		Chrgs for RTGS Cust Pymnt:ORBCH17093073271	29.00		11,17,267.78	

Account Statement for Account Number 14261131000892

1194	03/04/2017	03/04/2017	15373	RTGS- OW/ORBCH17093073271/G RAM TARANG EMPLOYABILITY	2,00,000.00		11,17,296.78	
------	------------	------------	-------	---	-------------	--	--------------	--

NOTE:

1. Computer generated entries shown in the Statement of Account do not require authentication/initial from the Bank Official. Please do not accept any manual entry in your computer generated Statement of Account.
2. Any discrepancy in the Account Statement should be brought to the notice of Branch immediately.

OFFICE OF THE DIRECTOR CAPITAL HOSPITAL BHUBANESWAR

Letter No 4368

Date 3/6/17

To

M/s Gram Tarang Employability Training
Services Pvt Ltd
Forest Park, Bhubaneswar

Sub.: Supply of E- Rickshaw to Capital Hospital, Bhubaneswar.

Dear Sir,

Please supply the following item to Capital Hospital, Bhubaneswar and submit the bills in triplicate along with Bank details for payment. The supply should be completed within 30 days from the date of issue of the order failing of which the order will be treated as cancelled.

Sl.No.	Name of the Item	Qty.	Rate	Amount
1	E-RICKSHAW Specification and terms & condition will be applicable as approved..	1 Nos	98,700.00	98,700.00
Total-				<u>98,700.00</u>

(Rupees Ninety eight thousand seven hundred)Only

Yours faithfully

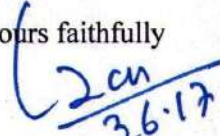
Director,

Capital Hospital, Bhubaneswar

Memo No. 4369 /CH, Bhubaneswar the 3/6/2017

Copy to Auditor In-charge, H&FW Deptt. / Accountant Capital Hospital, Bhubaneswar for information.

Director,

Capital Hospital, Bhubaneswar

OFFICE OF THE DIRECTOR, CAPITAL HOSPITAL, BHUBANESWAR

Email: substorechb@gmail.com / director.chb@gmail.com

Order No. 717 /

Date 20/1/18

File No. DCH/STORE/10-2016

To

Gram Tarang Employability Training Services Pvt.ltd
Forest Park,Bhubaneswar.

Sub: Supply of the item(s) to Capital Hospital, Bhubaneswar.

Ref- C H B/e-vehicle/17-18/013

Sir / Madam,

Please supply the following item(s) to Capital Hospital, Bhubaneswar and submit the bills in triplicate along with bank details for payment. The supply should be started immediately and completed within 15 days from the date of issue of the order failing of which the order will be treated as cancelled.

Sl. No.	Name of the Item, strength, specification etc. details	Qty.	Unit Cost (Rs.)	Total Cost (Rs.)
1	Batttery operated Patient Transporting Vehicle(Model-STAG-100AH)+Charger 48V+Delivery cost	2 Nos.	113,864.00	227,728.00

Total: 227,728.00

(Rupees Two lakh twenty seven thousand seven hundred twenty eight) only
(Including Taxes and all charges)

Supplier is requested to submit invoice in triplicate against each item mentioning "M.P LAD PURCHASE" along with copy of purchase order ,other terms & condition will be followed as laid down in the tender

Yours faithfully

2m
Director

Capital Hospital, Bhubaneswar

Memo No. 718 Date 20/1/18

Copy to Auditor In-charge, H&FW Deptt. / Accountant Capital Hospital, Bhubaneswar for information and necessary action.

2m
Director

Capital Hospital, Bhubaneswar

10
20/1/18

PURCHASE ORDER

ORIGINAL COPY



CENTRAL TOOL ROOM & TRAINING CENTRE

(A Government of India Society, Ministry of MSME)

B-36, CHANDKA INDUSTRIAL AREA, BHUBANESWAR - 751 024, ODISHA

Phone : Direct (0674) 3011710 (Purchase)

Fax : 91-674-2743061, Email : cttc@cttc.gov.in, Website : www.cttcbsr.co.in

ISO-9001, ISO-14001
OHSAS-18001
ISO-29990

M/s Gram Tarang Employability Training Services Private Limited
J.I.T.M Campus, Aluri Nagar, R.Sitapur
Paralakhemundi - 761211
Ph No: +91 891 6587657, 09437619974

Purchase/Work Order No.: - 1803040
Date: - 18.08.2018
Our Tender Enquiry No.: - As per N.S Approval
Date: - 06.08.2018
Your Ref. No.: - Nil
Date: - Nil
Indentor: - ARD

The undersigned is pleased to order the followings/accepts your tender mentioned above for supplies/services as detailed in the schedule below subject to terms and conditions mentioned under and over leaf herewith.

Sl. No.	Articles/Services to be supplied	Quantity	Unit	Unit Price		Amount	
				Rs.	P.	Rs.	P.
	Machining of Components						
1	Pressure Port 151510PD060 (TU/ML)	850	Ncs.	530.00		450500.00	
2	Clamping Ring (ADAPTOR) 120112PD090 (Milling)	26	Ncs.	860.00		22360.00	
3	Mounting Head 150910PD020 (TU/ML)	200	Ncs.	550.00		110000.00	
<p>Material shall be supplied By CTTC, Bhubaneswar Other Terms & Condition as per Enclosed Annex-I & Attached Checklist for the Supplier.</p> <p>Criteria of Acceptance: Approval of Sample & CTTC Inspection Report.</p> <p>OUR GST No: 21AAABC0056G1ZI As per GST rule two copies of invoice is to be furnished for release of payment.</p>							

Total in Words : (Rupees Five lakh eighty two thousand eight hundred and eighty) **582860.00**

TERMS & CONDITIONS

- | | |
|--------------------------------------|---|
| 1. Sales Tax : | GST : Extra as applicable |
| 2. Excise Duty : | nil |
| 3. Octroi Duty : | nil |
| 4. Any other Taxes / Duties if any : | nil |
| 5. Insurance : | nil |
| 6. Packing / Forwarding : | nil |
| 7. Mode of Transport and Charges : | nil |
| 8. Delivery Schedule | Delivery : As per Mutually agreed delivery schedule. |
| 9. Terms of Payment | Payment : Within 30 days of delivery & acceptance of items. |

Date -

Managing Director/
Authorised Official

PURCHASE ORDER

ORIGINAL COPY

**CENTRAL TOOL ROOM & TRAINING CENTRE**

(A Government of India Society, Ministry of MSME)

B-36, CHANDKA INDUSTRIAL AREA, BHUBANESWAR - 751 024, ODISHA

Phone : Direct (0674) 3011710 (Purchase)

Fax : 91-674-2743061, Email : cttc@cttc.gov.in, Website : www.cttcbsr.co.in

ISO-9001, ISO-14001
OHSAS-18001
ISO-29990

M/s Gram Tarang Employability Training Services Private Limited
J.I.T.M Campus, Aluri Nagar, R.Sitapur
Paralakhemundi - 761211
Ph No: +91 891 6587657, 09437619974

Purchase/Work Order No.: - 1803055
Date :- 24.09.2018
Our Tender Enquiry No.: - Enq by Prod. Committee (ST)
Date :- 09.09.2018
Your Ref. No.: - nil
Date :- 09.09.2018
Indentor :- SMP

The undersigned is pleased to order the followings/accepts your tender mentioned above for supplies/services as detailed in the schedule below subject to terms and conditions mentioned under and over leaf herewith.

Sl. No.	Articles/Services to be supplied	Quantity	Unit	Unit Price		Amount	
				Rs.	P.	Rs.	P.
<u>Machining of Components:-</u>							
1	Top Cover (DRG No-FIL-03-5051 , C)	100	Nos	450.00		45000.00	
2	Bottom Cover (DRG No-FIL-03-5052-C)	100	Nos	200.00		20000.00	
3	Top Cover (DRG No-FIL-04-5051,C)	100	Nos	450.00		45000.00	
4	Bottom Cover (DRG No-FIL-04-5052,C)	100	Nos	200.00		20000.00	
5	Top Cover (DRG No-FIL-05-5051,C)	100	Nos	450.00		45000.00	
6	Bottom Cover (DRG No-FIL-05-5052,C)	100	Nos	200.00		20000.00	
Other terms & condition as per enclosed Annex-II & attached Checklist for the supplier.							
<u>Criteria of Acceptance:</u> Approval of Sample & CTTC Inspection Report.							
Material shall be supplied by CTTC BBSR.							

Total in Words : (Rupees One lakh ninety five thousand Only)

In Figures : 195000.00

TERMS & CONDITIONS

- Sales Tax : Price Inclusive of GST (GST To be should be shown separately)
- Excise Duty : nil
- Octroi Duty : nil
- Any other Taxes / Duties if any : nil
- Insurance : nil
- Packing / Forwarding : nil
- Mode of Transport and Charges : nil
- Delivery Schedule : nil
- Terms of Payment : Delivery - Within 30 Days of receipt of material.
Payment - Within 30 days of delivery and acceptance of items.

Date -

Managing Director/
Authorised Official

PURCHASE ORDER

ORIGINAL COPY



CENTRAL TOOL ROOM & TRAINING CENTRE

(A Government of India Society, Ministry of MSME)

B-36, CHANDKA INDUSTRIAL AREA, BHUBANESWAR - 751 024, ODISHA

Phone : Direct (0674) 3011710 (Purchase)

Fax : 91-674-2743061, Email : cttc@cttc.gov.in, Website : www.cttcbbbsr.co.in

ISO-9001, ISO-14001
OHSAS-18001
ISO-29990

M/s Gram Tarang Employability Training Services Private Limited
J.I.T.M Campus, Aluri Nagar, R.Sitapur
Paralakhemundi - 761211
Ph No: +91 891 6587657, 09437619974

Purchase/Work Order No.: - 1703007

Date: - 01.05.2017

Our Tender Enquiry No. Enq by Prod. Committee (LT)

Date: - 25.04.2017

Your Ref. No.: - nil

Date: - 18.04.2017

Indentor: - ANP

The undersigned is pleased to order the followings/accepts your tender mentioned above for supplies/services as detailed in the schedule below subject to terms and conditions mentioned under and over leaf herewith.

Sl. No.	Articles/Services to be supplied	Quantity	Unit	Unit Price		Amount	
				Rs.	P.	Rs.	P.
Machining of Components:-							
1	Top Cover (FIL-01-5051/FIL-03-0003)	20	Nos	450.00		9000.00	
2	Bottom Cover (FIL-01-5052/FIL-03-0003)	20	Nos	200.00		4000.00	
3	Top Cover (FIL-01-5051/FIL-04-0004)	20	Nos	450.00		9000.00	
4	Bottom Cover (FIL-01-5052/FIL-04-0004)	20	Nos	200.00		4000.00	
<p>Other terms & condition as per enclosed Annex-II & attached Checklist for the supplier.</p> <p>Criteria of Acceptance: Approval of Sample & CTTC Inspection Report.</p> <p>Material shall be supplied by CTTC BBSR.</p>							

(Rupees Twenty Six Thousand Only)

Total in Words :

In Figures :

26000.00

TERMS & CONDITIONS

Price Inclusive of All Taxes (Taxes should be shown separately)

- Sales Tax : nil
- Excise Duty : nil
- Octroi Duty : nil
- Any other Taxes / Duties if any : nil
- Insurance : nil
- Packing / Forwarding : nil
- Mode of Transport and Charges : nil
- Delivery Schedule
- Terms of Payment

Delivery - Within 30 Days of receipt of material.

Payment - Within 30 days of delivery and acceptance of items.

Managing Director /
Authorised Official

Date -

PURCHASE ORDER

ORIGINAL COPY



CENTRAL TOOL ROOM & TRAINING CENTRE

(A Government of India Society, Ministry of MSME)

B-36, CHANDKA INDUSTRIAL AREA, BHUBANESWAR - 751 024, ODISHA

Phone : Direct (0674) 3011710 (Purchase)

Fax : 91-674-2743061, Email : cttc@cttc.gov.in, Website : www.cttcbbbsr.co.in

ISO-9001, ISO-14001
OHSAS-18001
ISO-29990
1703022

M/s Gram Tarang Employability Training Services Private Limited
J.I.T.M Campus, Aluri Nagar, R.Sitapur
Paralakhemundi - 761211
Ph No: +91 891 6587657, 09437619974

Purchase/Work Order No.: -

07.06.2017

Date :-

Repeat Order (LT)

Our Tender Enquiry No.:-

1703007/01.05.2017

Date :-

Your Ref. No.:-

nil

Date :-

18.04.2017

Indentor :-

ANP

The undersigned is pleased to order the followings/accepts your tender mentioned above for supplies/services as detailed in the schedule below subject to terms and conditions mentioned under and over leaf herewith.

Sl. No.	Articles/Services to be supplied	Quantity	Unit	Unit Price		Amount	
				Rs.	P.	Rs.	P.
	<u>Machining of Components:-</u>						
1	Top Cover (FIL-01-5051/FIL-04-0004)	20	Nos	450.00		9000.00	
2	Bottom Cover (FIL-01-5052/FIL-04-0004)	20	Nos	200.00		4000.00	
<p>Other terms & condition as per enclosed Annex-II & attached Checklist for the supplier. <u>Criteria of Acceptance:</u> Approval of Sample & CTTC Inspection Report. Material shall be supplied by CTTC BBSR.</p>							
Total in Words : (Rupees Thirteen Thousand Only)						13000.00	
Total in Words :				In Figures :			

TERMS & CONDITIONS

- Sales Tax :
- Excise Duty :
- Octroi Duty :
- Any other Taxes / Duties if any :
- Insurance :
- Packing / Forwarding :
- Mode of Transport and Charges :
- Delivery Schedule
- Terms of Payment

Price Inclusive of All Taxes (Taxes should be shown separately)

nil

nil

nil

nil

nil

nil

Delivery - Within 30 Days of receipt of material.

Payment - Within 30 days of delivery and acceptance of items.

Managing Director/
Authorised Official

Date -

PURCHASE ORDER

.. ORIGINAL COPY



सूक्ष्म लघु एवं मध्यम उद्यम
MICRO, SMALL & MEDIUM ENTERPRISES

CENTRAL TOOL ROOM & TRAINING CENTRE

(A Government of India Society, Ministry of MSME)

B-36, CHANDKA INDUSTRIAL AREA, BHUBANESWAR - 751 024, ODISHA

Phone : Direct (0674) 3011710 (Purchase)

Fax : 91-674-2743061, Email : cttc@cttc.gov.in, Website : www.cttcbsr.co.in



ISO-9001, ISO-14001
OHSAS-18001
ISO-29990

M/s Gram Tarang Employability Training Services Private Limited
J.I.T.M Campus, Aluri Nagar, R.Sitapur
Paralakhemundi - 761211
Ph No: +91 891 6587657, 09437619974

Purchase/Work Order No.: - 1603080
Date: - 20.12.2016
Our Tender Enquiry No.: - Committee Recommended
Date :- nil
Your Ref. No.: - nil
Date :- 06.12.2016
Indentor :- AKP

The undersigned is pleased to order the followings/accepts your tender mentioned above for supplies/services as detailed in the schedule below subject to terms and conditions mentioned under and over leaf herewith.

Sl. No.	Articles/Services to be supplied	Quantity	Unit	Unit Price		Amount	
				Rs.	P.	Rs.	P.
1	Housing(B)	64	Nos	340.00		21760.00	
2	C.Ring(B&S)	96	Nos	355.00		34080.00	
3	Housing(V)	8	Nos	345.00		2760.00	
4	C.Ring(V)	8	Nos	165.00		1320.00	
5	Housing(S)	32	Nos	340.00		10880.00	
6	Cover(CRC)	32	Nos	1100.00		35200.00	

Other terms & condition as per enclosed Annex-I & attached Checklist for the supplier.
Criteria of Acceptance:
Approval of Sample & CTTC Inspection Report.

Material shall be supplied by CTTC, BBSR.

Total in Words : (Rupees One lakhs Six Thousand Only)

In Figures :

106000.00

TERMS & CONDITIONS

- | | |
|--------------------------------------|---|
| 1. Sales Tax : | Service Tax - Extra. |
| 2. Excise Duty : | nil |
| 3. Octroi Duty : | nil |
| 4. Any other Taxes / Duties if any : | nil |
| 5. Insurance : | nil |
| 6. Packing / Forwarding : | nil |
| 7. Mode of Transport and Charges : | nil |
| 8. Delivery Schedule | Delivery - Within 30 Days of receipt of material. |
| 9. Terms of Payment | Payment - Within 30 days of delivery and acceptance of items. |

Date -

General Manager/
Authorised Official

PURCHASE ORDER

ORIGINAL COPY



सूक्ष्म लघु एवं मध्यम उद्यम
MICRO, SMALL & MEDIUM ENTERPRISES

CENTRAL TOOL ROOM & TRAINING CENTRE

(A Government of India Society, Ministry of MSME)

B-36, CHANDKA INDUSTRIAL AREA, BHUBANESWAR - 751 024, ODISHA

Phone : Direct (0674) 3011710 (Purchase)

Fax : 91-674-2743061, Email : ctcc@cttc.gov.in, Website : www.cttcbsr.co.in



ISO-9001, ISO-14001
OHSAS-18001
ISO-29990

M/s Gram Tarang Employability Training Services Private Limited J.I.T.M Campus, Aluri Nagar, R.Sitapur Paralakhemundi - 761211 Ph No: +91 891 6587657, 09437619974	Purchase/Work Order No.:-	1603046
	Date :-	08.09.2016
	Our Tender Enquiry No.:-	Enq. By Prod. Committee (LT)
	Date :-	01.09.2016
	Your Ref. No.:-	GTET/PKD/008
	Date :-	01.09.2016
	Indentor :-	A.Rashid

The undersigned is pleased to order the followings/accepts your tender mentioned above for supplies/services as detailed in the schedule below subject to terms and conditions mentioned under and over leaf herewith.

Sl. No.	Articles/Services to be supplied	Quantity	Unit	Unit Price		Amount		
				Rs.	P.	Rs.	P.	
1	Machining of Components Punch as per our Drg. No: V5/PT/0064	300	Nos	125.00		37500.00		
2	Housing Lower Half as per our Drg No: 1001204-A	65	Nos	1500.00		97500.00		
Other terms & condition as per enclosed Annex-I & attached Checklist for the supplier . <u>Criteria of Acceptance:</u> Approval of Sample and CTTC Inspection								

Total in Words : (Rupees One Lakh Thirty Five Thousand Only) In Figures : 135000.00

TERMS & CONDITIONS

- Price inclusive of all taxes (Taxes should be shown separately)
- Sales Tax : nil
 - Excise Duty : nil
 - Octroi Duty : nil
 - Any other Taxes / Duties if any : nil
 - Insurance : nil
 - Packing / Forwarding : nil
 - Mode of Transport and Charges : FOR CTTC BBSR
 - Delivery Schedule : Delivery: Within 30 days of receipt of material.
 - Terms of Payment : Payment : Within 15 days of delivery and acceptance of items.

Date -

General Manager
Authorized Official

Central Tool Room & Training Centre
Bhubaneswar

PURCHASE ORDER

INDENT COPY



CENTRAL TOOL ROOM & TRAINING CENTRE

(A Government of India Society, Ministry of MSME)
B-36, CHANDKA INDUSTRIAL AREA, BHUBANESWAR - 751 024, ODISHA
Phone : Direct (0674) 3297116 (Purchase)
Fax : 91-674- 2743061, Email : cttc@satyam.net.in, Website : www.cttcbsr.co.in



M/s Gram Tarang Employability Training Services Private Limited
J.I.T.M. Campus, Aluri Nagar
R.Sitapur, Paralakhemundi - 761211
Ph No: +91 891 6587657 / 09437619974

Purchase/Work Order No.: - 1603009
Date: - 29.04.2016
Our Tender Enquiry No: - Enq by Prod. Committee(LT)
Date :- 27.04.2016
Your Ref. No.: - GTET/PKD/004
Date :- 23.04.2016
Indentor :- KVK

The undersigned is pleased to order the followings/accepts your tender mentioned above for supplies/services as detailed in the schedule below subject to terms and conditions mentioned under and over leaf herewith.

Sl. No.	Articles/Services to be supplied	Quantity	Unit	Unit Price Rs. P.	Amount Rs. P.
1	Bellow Support As per Our Enclosed Drawing - I Drawing No : 15 12 28 PD 02 01 Other terms & condition as per enclosed Annex-I & attached Checklist for the supplier. Criteria of Acceptance: Sample to be Approved & CTTC Inspection Report	650	Nos	150.00	97500.00

Total in Words: (Rupees Ninety Seven Thousand Five Hundred Only) In Figures : 97,500.00

TERMS & CONDITIONS

- Sales Tax : Price inclusive of All Taxes (VAT should be shown separately)
- Excise Duty : nil
- Octroi Duty : nil
- Any other Taxes / Duties if any : nil
- Insurance : nil
- Packing / Forwarding : nil
- Mode of Transport and Charges : nil
- Delivery Schedule : Delivery - Within 30 Days of receipt of material.
- Terms of Payment : Payment - Within 15 days of acceptance of items

General Manager/
Authorised Official

Date -

Indentor's Signature
Date.....

PURCHASE ORDER

ORIGINAL COPY



CENTRAL TOOL ROOM & TRAINING CENTRE

(A Government of India Society, Ministry of MSME)

B-36, CHANDKA INDUSTRIAL AREA, BHUBANESWAR - 751 024, ODISHA

Phone : Direct (0674) 3011710 (Purchase)

Fax : 91-674-2743061, Email : cttc@cttc.gov.in, Website : www.cttcbsr.co.in

ISO-9001, ISO-14001
OHSAS-18001
ISO-29990

M/s Gram Tarang Employability Training Services Private Limited
J.I.T.M Campus, Aluri Nagar, R.Sitapur
Paralakhemundi - 761211
Ph No: +91 891 6587657, 09437619974

Purchase/Work Order No.: - 1603075
Date 16.12.2016
Our Tender Enquiry No.: - TE-55 (LT)
Date :- 29.06.2016
Your Ref. No.: - nil
Date :- nil
Indentor :- A.Rashid

The undersigned is pleased to order the followings/accepts your tender mentioned above for supplies/services as detailed in the schedule below subject to terms and conditions mentioned under and over leaf herewith.

Sl. No.	Articles/Services to be supplied	Quantity	Unit	Unit Price		Amount	
				Rs.	P.	Rs.	P.
1	Machining of Components as per Enclosed annexure-I						226095.00
<p>Other terms & condition as per enclosed Annex-II & attached Checklist for the supplier</p> <p>Criteria of Acceptance: Approval of Sample & CTTC Inspection Report.</p> <p>Material shall be supplied by CTTC BBSR.</p>							

Total in Words : (Rupees Two Lakh Twenty Six Thousand Ninety Five Only)

226095.00

TERMS & CONDITIONS

- Sales Tax :
- Excise Duty :
- Octroi Duty :
- Any other Taxes / Duties if any :
- Insurance :
- Packing / Forwarding :
- Mode of Transport and Charges :
- Delivery Schedule
- Terms of Payment

Price Inclusive of All Taxes (Taxes should be shown separately)

nil

nil

nil

nil

nil

nil

Delivery - Within 30 Days of receipt of material.

Payment - Within 30 days of delivery and acceptance of items.

General Manager/
Authorised Official

Date -

PURCHASE ORDER

ORIGINAL COPY



CENTRAL TOOL ROOM & TRAINING CENTRE

(A Government of India Society, Ministry of MSME)

B-36, CHANDKA INDUSTRIAL AREA, BHUBANESWAR - 751 024, ODISHA

Phone : Direct (0674) 3011710 (Purchase)

Fax : 91-674-2743061, Email : cttc@cttc.gov.in, Website : www.cttcbbbsr.co.in

ISO-9001, ISO-14001
OHSAS-18001
ISO-29990

M/s Gram Tarang Employability Training Services Private Limited
J.I.T.M Campus, Aluri Nagar, R.Sitapur
Paralakhemundi - 761211
Ph No: +91 891 6587657, 09437619974

Purchase/Work Order No.:-

1703074

Date :-

07.08.2017

Our Tender Enquiry No.:-

As per N.S. Approva

Date :-

06.12.2017

Your Ref. No.:-

Nil

Date :-

Nil

Indentor :-

KVK

The undersigned is pleased to order the followings/accepts your tender mentioned above for supplies/services as detailed in the schedule below subject to terms and conditions mentioned under and over leaf herewith.

Sl. No.	Articles/Services to be supplied	Quantity	Unit	Unit Price		Amount	
				Rs.	P.	Rs.	P.
1	<p>Machining of components as per enclosed annexure-I</p> <p>Material shall be supplied by CTTC BBSR.</p> <p>Other terms & condition as per enclosed Annex-II & attached Checklist for the supplier.</p> <p>Criteria of Acceptance: Approval of Sample & CTTC Inspection Report.</p> <p>OUR GST No: 21AAABC0056G1ZI As per GST rule two copies of invoice is to be furnished for release of payment.</p>						578990.00

Total in Words (Rupees Five Lakh Seventy Eight Thousand Nine Hundred Ninety Only)

578990.00

TERMS & CONDITIONS

- Sales Tax : GST: As mentioned in annexure (GST to be shown separately)
- Excise Duty : nil
- Octroi Duty : nil
- Any other Taxes / Duties if any : nil
- Insurance : nil
- Packing / Forwarding : nil
- Mode of Transport and Charges : nil
- Delivery Schedule : nil
- Terms of Payment : Delivery - Within 30 Days of receipt of material.
Payment - Within 30 days of delivery and acceptance of items.

Date -

Managing Director/
Authorised Official



Journal Voucher

No. : JV/06/78

Dated : 30-Jun-2017

Particulars		Amount
Organisation for Develop Integration & Social Action	<i>Dr</i> 1,20,000.00	
To Grant in Aid (ODISA) ODISA - Strategy	1,04,350.00 <i>Cr</i>	1,04,350.00
To Service Tax Payable (Output)		15,650.00
On Account of : Being amount provisioned towards project cost		
		Rs. 1,20,000.00
		Rs. 1,20,000.00

Authorised Signatory

**Training for the Development of
Strategic Plan for Organisation for Development
Integration and Social Action (ODISA), Berhampur
Odisha**

Submitted to

**Development Integration and Social Action (ODISA)
Berhampur, Odisha**

By

**Prof. Haribandhu Panda, Ph.D.
Vice Chancellor**



**Centurion
UNIVERSITY**

**Ramchandrapur, Jatni, Khurda, 752050, Odisha
<http://www.cutm.ac.in>**

March 2017

Training for the Development of Strategic Plan for Development Integration and Social Action (ODISA), Berhampur, Odisha

1. Introduction

Development Integration and Social Action (ODISA) is interested to undertake a training program for its employees for developing a strategic plan for the organization. This document indicates the process that is to be followed for the task.

2. Objectives

The broad objective of the task is to develop a strategic plan for the organization after undertaking a thorough analysis of the environment in which the organization works, understanding the resources in its disposal and assessing the stakeholders. The specific objectives of the task include

- i. Developing a shared mission and vision of the organisation
- ii. Identify the key drivers of change, opportunities and threats in organisations' environment
- iii. Strength and weaknesses of the resources of the organization;
- iv. Power and interest of its stakeholders in influencing the decisions
- v. Generating alternative strategies and choosing an appropriate one, and
- vi. Developing an implementable strategic plan.

3. Methodology

The study will use tools such as SWOT Analysis, Stakeholder Analysis, Value Chain Analysis and strategy management framework. Adult learning approach of action-reflection-action mode will be used. Training will be in two phases. In Phase I, for 3 days, concepts/frameworks will be explained and participants will be led to develop a preliminary strategic plan based on the information available with them. Then, after six weeks, in a 2 days' program, participants will present the plan developed by them, taking note of the comments given in the first phase and continuous feedback received in the intervening period. The program will be held outside their office in workshop mode.

4. Fee

- i. Resource persons: At the rate of Rs 15,000/day for 5 days workshop and 3 days preparation/feedback and handholding = Rs 120,000
- ii. Transportation cost: Actual
- iii. Lodging and Boarding: Actual

Payment schedule: Fees to be paid to the Centurion University of Technology and Management. 50% advance along with the award of the project. Balance 50% after the submission of commented Strategic Plan.

5. Resource Person

Prof. Haribandhu Panda will be Principal Resource person. He will be supported by a team of faculty members with expertise in institution development and strategic planning.



SCHEDULE OF JAN 2018

1 message

Krishnamurari Prasad <krishnamurari.prasad@rsbglobal.com>
 Reply-To: krishnamurari.prasad@rsbglobal.com
 To: Aurobindo Sahu <aurobindosahu@gmail.com>
 Cc: muraripsd001@gmail.com

Sun, Dec 31, 2017 at 3:26 PM

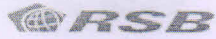

RSB Transmissions (I) Ltd.

Schedule No. :-

PLOT NO. 184 & 189 Belur Industrial Area

Schedule Month :-jan 2018

Dharwad

To

GramTarang Employability Trng

orriisa

Kind Atten. Mr. arvindo shahu

Sl.No.	PO Number	Description	Quantity Open	Quantity Open	Confirm Zone		Tentative Zone		
					Qty	Delivery Date	FEB'18	MAR'18	april'18
1		21320190091P12P	SEAT SCREW 4337930	4,800	400.00	01.01.18	400	400	400
2		21320190086P12P	SEAT SCREW 4190634	3,360	300.00	01.01.18	200	200	200
3		21320190087P00P	SEAT SCREW 4190636	1,680	150.00	01.01.18	100	100	100
4		21320190088P00P	SEAT SCREW 4190635	840	150.00	01.01.18	100	100	100
5		21320190008P00P	SEAT SCREW TE05275	24,480	2,000.00	01.01.18	2040	2040	2040
6		21320190094P00P	SEAT SCREW 4195689	48,000	6,000.00	01.01.18	4000	4000	4000

Kindly Despatch The Materials as per above Schedule . If There Is any changes we will Inform accordingly.

Thanking You

For RSB Transmission (I) Ltd.- Dharwad

FORMAT NO. RSB-D/PUR/10

REV NO & DATE :
00/01.08.09

Krishan murariprasad

schudule of may 2017

1 message

Krishnamurari Prasad <krishnamurari.prasad@rsbglobal.com>
 Reply-To: krishnamurari.prasad@rsbglobal.com
 To: Aurobindo Sahu <aurobindosahu@gmail.com>

Tue, May 9, 2017 at 5:52 PM



RSB Transmissions (I) Ltd.

Schedule No. :-

PLOT NO. 184 & 189 Belur Industrial Area

Schedule Month :-MAY 2017

Dharwad

To

GramTarang Employability Trng

orisa

Kind Atten. Mr. arvindo shahu

Sl.No.	PO Number	Description	Quantity Open	Quantity Open	Confirm Zone		Tentative Zone		
					Qnty	Delivery Date	JUN,17	JULY,17	AUG'17
1		21320190091P12P	SEAT SCREW 4337930	4,800	500.00	06.05.17	400	400	400
2		21320190086P12P	SEAT SCREW 4190634	3,360	200.00	06.05.17	280	280	280
3		21320190087P00P	SEAT SCREW 4190636	1,680	100.00	06.05.17	140	140	140
4		21320190088P00P	SEAT SCREW 4190635	840	100.00	06.05.17	140	140	140
5		21320190008P00P	SEAT SCREW TE05275	24,480	2,000.00	06.05.17	2040	2040	2040
6		21320190094P00P	SEAT SCREW 4195689	48,000	6,000.00	06.05.17	4000	4000	4000

Kindly Despatch The Materials as per above Schedule . If There Is any changes we will Inform accordingly.

Thanking You

For RSB Transmission (I) Ltd.- Dharwad

FORMAT NO. RSB-D/PUR/10

REV NO & DATE :
00/01.08.09

Krishan murari Prasad

RSB TRANSMISSIONS (I) LTD

BELUR IND AREA

RSB Transmissions (I) Ltd.
 PLOT NO. 184 & 189 Belur Industrial Area
 Dhanwad

Schedule No. :-
 Schedule Month :- April 2016

To
 Gram Tarang Employability Trng
 orrisa

Kind Atten. Mr. arvindo shahu

Sl.No.	PO Number	Description	Quantity Open	Quantity Open	Confirm Zone		Tentative Zone		
					Qty	Delivery Date	MAY'16	JUNE'16	JULY'16
1		21320190091P12P	SEAT SCREW 4337930	4,800	400.00	01.04.16	400	400	400
2		21320190086P12P	SEAT SCREW 4190634	3,360	300.00	01.04.16	200	200	200
3		21320190087P00P	SEAT SCREW 4190636	1,680	150.00	01.04.16	100	100	100
4		21320190088P00P	SEAT SCREW 4190635	840	150.00	01.04.16	100	100	100
5		21320190008P00P	SEAT SCREW TE05275	12000	1,000.00	01.04.16	1000	1000	1000
6		21320190094P00P	SEAT SCREW 4195689	32,000	4,000.00	01.04.16	4000	4000	4000

Kindly Despatch The Materials as per above Schedule . If There is any changes we will Inform accordingly.

Thanking You
 For RSB Transmission (I) Ltd. - Dhanwad

REV NO & DATE :
 04/01.04.16

Krishan murariprasad
 RSB
 TRANSMISSIONS(I)LTD
 DHARWD

PURCHASE ORDER

ORIGINAL COPY



CENTRAL TOOL ROOM & TRAINING CENTRE

(A Government of India Society, Ministry of MSME)

B-36, CHANDKA INDUSTRIAL AREA, BHUBANESWAR - 751 024, ODISHA

Phone : Direct (0674) 3011710 (Purchase)

Fax : 91-674-2743061, Email : cttc@cttc.gov.in, Website : www.cttcbsr.co.in

ISO-9001, ISO-14001
OHSAS-18001
ISO-29990

M/s Gram Tarang Employability Training Services Private Limited
J.I.T.M Campus, Aluri Nagar, R.Sitapur
Paralakhemundi - 761211
Ph No: +91 891 6587657, 09437619974

Purchase/Work Order No.: - 1803040
Date: - 18.08.2018
Our Tender Enquiry No.: - As per N.S Approval
Date: - 06.08.2018
Your Ref. No.: - Nil
Date: - Nil
Indentor: - ARD

The undersigned is pleased to order the followings/accepts your tender mentioned above for supplies/services as detailed in the schedule below subject to terms and conditions mentioned under and over leaf herewith.

Sl. No.	Articles/Services to be supplied	Quantity	Unit	Unit Price		Amount	
				Rs.	P.	Rs.	P.
	Machining of Components						
1	Pressure Port 151510PD060 (TU/ML)	850	Ncs.	530.00		450500.00	
2	Clamping Ring (ADAPTOR) 120112PD090 (Milling)	26	Ncs.	860.00		22360.00	
3	Mounting Head 150910PD020 (TU/ML)	200	Ncs.	550.00		110000.00	
<p>Material shall be supplied By CTTC, Bhubaneswar Other Terms & Condition as per Enclosed Annex-I & Attached Checklist for the Supplier.</p> <p>Criteria of Acceptance: Approval of Sample & CTTC Inspection Report.</p> <p>OUR GST No: 21AAABC0056G1ZI As per GST rule two copies of invoice is to be furnished for release of payment.</p>							

Total in Words : (Rupees Five lakh eighty two thousand eight hundred and eighty) **582860.00**

TERMS & CONDITIONS

- | | |
|--------------------------------------|---|
| 1. Sales Tax : | GST : Extra as applicable |
| 2. Excise Duty : | nil |
| 3. Octroi Duty : | nil |
| 4. Any other Taxes / Duties if any : | nil |
| 5. Insurance : | nil |
| 6. Packing / Forwarding : | nil |
| 7. Mode of Transport and Charges : | nil |
| 8. Delivery Schedule | Delivery : As per Mutually agreed delivery schedule. |
| 9. Terms of Payment | Payment : Within 30 days of delivery & acceptance of items. |

Date -

Managing Director/
Authorised Official

PURCHASE ORDER

ORIGINAL COPY



CENTRAL TOOL ROOM & TRAINING CENTRE

(A Government of India Society, Ministry of MSME)

B-36, CHANDKA INDUSTRIAL AREA, BHUBANESWAR - 751 024, ODISHA

Phone : Direct (0674) 3011710 (Purchase)

Fax : 91-674-2743061, Email : cttc@cttc.gov.in, Website : www.cttcbsr.co.in

ISO-9001, ISO-14001
OHSAS-18001
ISO-29990

M/s Gram Tarang Employability Training Services Private Limited
J.I.T.M Campus, Aluri Nagar, R.Sitapur
Paralakhemundi - 761211
Ph No: +91 891 6587657, 09437619974

Purchase/Work Order No.: - 1803055
Date :- 24.09.2018
Our Tender Enquiry No.: - Enq by Prod. Committee (ST)
Date :- 09.09.2018
Your Ref. No.: - nil
Date :- 09.09.2018
Indenter :- SMP

The undersigned is pleased to order the followings/accepts your tender mentioned above for supplies/services as detailed in the schedule below subject to terms and conditions mentioned under and over leaf herewith.

Sl. No.	Articles/Services to be supplied	Quantity	Unit	Unit Price		Amount	
				Rs.	P.	Rs.	P.
<u>Machining of Components:-</u>							
1	Top Cover (DRG No-FIL-03-5051 , C)	100	Nos	450.00		45000.00	
2	Bottom Cover (DRG No-FIL-03-5052-C)	100	Nos	200.00		20000.00	
3	Top Cover (DRG No-FIL-04-5051,C)	100	Nos	450.00		45000.00	
4	Bottom Cover (DRG No-FIL-04-5052,C)	100	Nos	200.00		20000.00	
5	Top Cover (DRG No-FIL-05-5051,C)	100	Nos	450.00		45000.00	
6	Bottom Cover (DRG No-FIL-05-5052,C)	100	Nos	200.00		20000.00	
Other terms & condition as per enclosed Annex-II & attached Checklist for the supplier.							
<u>Criteria of Acceptance:</u>							
Approval of Sample & CTTC Inspection Report.							
Material shall be supplied by CTTC BBSR.							

Total in Words : (Rupees One lakh ninety five thousand Only)

In Figures : 195000.00

TERMS & CONDITIONS

- Sales Tax : Price Inclusive of GST (GST To be should be shown separately)
- Excise Duty : nil
- Octroi Duty : nil
- Any other Taxes / Duties if any : nil
- Insurance : nil
- Packing / Forwarding : nil
- Mode of Transport and Charges : nil
- Delivery Schedule : nil
- Terms of Payment : Delivery - Within 30 Days of receipt of material.
Payment - Within 30 days of delivery and acceptance of items.

Date -

Managing Director/
Authorised Official

PURCHASE ORDER

ORIGINAL COPY



CENTRAL TOOL ROOM & TRAINING CENTRE

(A Government of India Society, Ministry of MSME)

B-36, CHANDKA INDUSTRIAL AREA, BHUBANESWAR - 751 024, ODISHA

Phone : Direct (0674) 3011710 (Purchase)

Fax : 91-674-2743061, Email : cttc@cttc.gov.in, Website : www.cttcbbbsr.co.in

ISO-9001, ISO-14001
OHSAS-18001
ISO-29990

M/s Gram Tarang Employability Training Services Private Limited
J.I.T.M Campus, Aluri Nagar, R.Sitapur
Paralakhemundi - 761211
Ph No: +91 891 6587657, 09437619974

Purchase/Work Order No.: - 1703007

Date: - 01.05.2017

Our Tender Enquiry No. Enq by Prod. Committee (LT)

Date: - 25.04.2017

Your Ref. No.: - nil

Date: - 18.04.2017

Indentor: - ANP

The undersigned is pleased to order the followings/accepts your tender mentioned above for supplies/services as detailed in the schedule below subject to terms and conditions mentioned under and over leaf herewith.

Sl. No.	Articles/Services to be supplied	Quantity	Unit	Unit Price		Amount	
				Rs.	P.	Rs.	P.
Machining of Components:-							
1	Top Cover (FIL-01-5051/FIL-03-0003)	20	Nos	450.00		9000.00	
2	Bottom Cover (FIL-01-5052/FIL-03-0003)	20	Nos	200.00		4000.00	
3	Top Cover (FIL-01-5051/FIL-04-0004)	20	Nos	450.00		9000.00	
4	Bottom Cover (FIL-01-5052/FIL-04-0004)	20	Nos	200.00		4000.00	
<p>Other terms & condition as per enclosed Annex-II & attached Checklist for the supplier.</p> <p>Criteria of Acceptance: Approval of Sample & CTTC Inspection Report.</p> <p>Material shall be supplied by CTTC BBSR.</p>							

(Rupees Twenty Six Thousand Only)

Total in Words :

In Figures :

26000.00

TERMS & CONDITIONS

Price Inclusive of All Taxes (Taxes should be shown separately)

- Sales Tax : nil
- Excise Duty : nil
- Octroi Duty : nil
- Any other Taxes / Duties if any : nil
- Insurance : nil
- Packing / Forwarding : nil
- Mode of Transport and Charges : nil
- Delivery Schedule
- Terms of Payment

Delivery - Within 30 Days of receipt of material.

Payment - Within 30 days of delivery and acceptance of items.

Managing Director /
Authorised Official

Date -

PURCHASE ORDER

ORIGINAL COPY



CENTRAL TOOL ROOM & TRAINING CENTRE

(A Government of India Society, Ministry of MSME)

B-36, CHANDKA INDUSTRIAL AREA, BHUBANESWAR - 751 024, ODISHA

Phone : Direct (0674) 3011710 (Purchase)

Fax : 91-674-2743061, Email : cttc@cttc.gov.in, Website : www.cttcbbbsr.co.in

ISO-9001, ISO-14001
OHSAS-18001
ISO-29990
1703022

M/s Gram Tarang Employability Training Services Private Limited
J.I.T.M Campus, Aluri Nagar, R.Sitapur
Paralakhemundi - 761211
Ph No: +91 891 6587657, 09437619974

Purchase/Work Order No.: -

07.06.2017

Date :-

Repeat Order (LT)

Our Tender Enquiry No.:-

1703007/01.05.2017

Date :-

Your Ref. No.:-

nil

Date :-

18.04.2017

Indentor :-

ANP

The undersigned is pleased to order the followings/accepts your tender mentioned above for supplies/services as detailed in the schedule below subject to terms and conditions mentioned under and over leaf herewith.

Sl. No.	Articles/Services to be supplied	Quantity	Unit	Unit Price		Amount	
				Rs.	P.	Rs.	P.
<u>Machining of Components:-</u>							
1	Top Cover (FIL-01-5051/FIL-04-0004)	20	Nos	450.00		9000.00	
2	Bottom Cover (FIL-01-5052/FIL-04-0004)	20	Nos	200.00		4000.00	
<p>Other terms & condition as per enclosed Annex-II & attached Checklist for the supplier.</p> <p><u>Criteria of Acceptance:</u> Approval of Sample & CTTC Inspection Report.</p> <p>Material shall be supplied by CTTC BBSR.</p>							
Total in Words : (Rupees Thirteen Thousand Only)						13000.00	
Total in Words :				In Figures :			

TERMS & CONDITIONS

- Sales Tax :
- Excise Duty :
- Octroi Duty :
- Any other Taxes / Duties if any :
- Insurance :
- Packing / Forwarding :
- Mode of Transport and Charges :
- Delivery Schedule
- Terms of Payment

Price Inclusive of All Taxes (Taxes should be shown separately)

nil

nil

nil

nil

nil

nil

Delivery - Within 30 Days of receipt of material.

Payment - Within 30 days of delivery and acceptance of items.

Managing Director/
Authorised Official

Date -

PURCHASE ORDER

.. ORIGINAL COPY



सूक्ष्म लघु एवं मध्यम उद्यम
MICRO, SMALL & MEDIUM ENTERPRISES

CENTRAL TOOL ROOM & TRAINING CENTRE

(A Government of India Society, Ministry of MSME)

B-36, CHANDKA INDUSTRIAL AREA, BHUBANESWAR - 751 024, ODISHA

Phone : Direct (0674) 3011710 (Purchase)

Fax : 91-674-2743061, Email : cttc@cttc.gov.in, Website : www.cttcbsr.co.in



ISO-9001, ISO-14001
OHSAS-18001
ISO-29990

M/s Gram Tarang Employability Training Services Private Limited
J.I.T.M Campus, Aluri Nagar, R.Sitapur
Paralakhemundi - 761211
Ph No: +91 891 6587657, 09437619974

Purchase/Work Order No.: - 1603080
Date: - 20.12.2016
Our Tender Enquiry No.: - Committee Recommended
Date :- nil
Your Ref. No.: - nil
Date :- 06.12.2016
Indentor :- AKP

The undersigned is pleased to order the followings/accepts your tender mentioned above for supplies/services as detailed in the schedule below subject to terms and conditions mentioned under and over leaf herewith.

Sl. No.	Articles/Services to be supplied	Quantity	Unit	Unit Price		Amount	
				Rs.	P.	Rs.	P.
1	Housing(B)	64	Nos	340.00		21760.00	
2	C.Ring(B&S)	96	Nos	355.00		34080.00	
3	Housing(V)	8	Nos	345.00		2760.00	
4	C.Ring(V)	8	Nos	165.00		1320.00	
5	Housing(S)	32	Nos	340.00		10880.00	
6	Cover(CRC)	32	Nos	1100.00		35200.00	

Other terms & condition as per enclosed Annex-I & attached Checklist for the supplier.
Criteria of Acceptance:
Approval of Sample & CTTC Inspection Report.

Material shall be supplied by CTTC, BBSR.

Total in Words : (Rupees One lakhs Six Thousand Only)

In Figures :

106000.00

TERMS & CONDITIONS

- | | |
|--------------------------------------|---|
| 1. Sales Tax : | Service Tax - Extra. |
| 2. Excise Duty : | nil |
| 3. Octroi Duty : | nil |
| 4. Any other Taxes / Duties if any : | nil |
| 5. Insurance : | nil |
| 6. Packing / Forwarding : | nil |
| 7. Mode of Transport and Charges : | nil |
| 8. Delivery Schedule | Delivery - Within 30 Days of receipt of material. |
| 9. Terms of Payment | Payment - Within 30 days of delivery and acceptance of items. |

Date -

General Manager/
Authorised Official

PURCHASE ORDER

ORIGINAL COPY



सूक्ष्म लघु एवं मध्यम उद्यम
MICRO, SMALL & MEDIUM ENTERPRISES

CENTRAL TOOL ROOM & TRAINING CENTRE

(A Government of India Society, Ministry of MSME)

B-36, CHANDKA INDUSTRIAL AREA, BHUBANESWAR - 751 024, ODISHA

Phone : Direct (0674) 3011710 (Purchase)

Fax : 91-674-2743061, Email : ctcc@cttc.gov.in, Website : www.cttcbsr.co.in



ISO-9001, ISO-14001
OHSAS-18001
ISO-29990

M/s Gram Tarang Employability Training Services Private Limited J.I.T.M Campus, Aluri Nagar, R.Sitapur Paralakhemundi - 761211 Ph No: +91 891 6587657, 09437619974	Purchase/Work Order No.:-	1603046
	Date :-	08.09.2016
	Our Tender Enquiry No.:-	Enq. By Prod. Committee (LT)
	Date :-	01.09.2016
	Your Ref. No.:-	GTET/PKD/008
	Date :-	01.09.2016
	Indentor :-	A.Rashid

The undersigned is pleased to order the followings/accepts your tender mentioned above for supplies/services as detailed in the schedule below subject to terms and conditions mentioned under and over leaf herewith.

Sl. No.	Articles/Services to be supplied	Quantity	Unit	Unit Price		Amount		
				Rs.	P.	Rs.	P.	
1	Machining of Components Punch as per our Drg. No: V5/PT/0064	300	Nos	125.00		37500.00		
2	Housing Lower Half as per our Drg No: 1001204-A	65	Nos	1500.00		97500.00		
Other terms & condition as per enclosed Annex-I & attached Checklist for the supplier . <u>Criteria of Acceptance:</u> Approval of Sample and CTTC Inspection								

Total in Words : (Rupees One Lakh Thirty Five Thousand Only) In Figures : 135000.00

TERMS & CONDITIONS

- Price inclusive of all taxes (Taxes should be shown separately)
- Sales Tax : nil
 - Excise Duty : nil
 - Octroi Duty : nil
 - Any other Taxes / Duties if any : nil
 - Insurance : nil
 - Packing / Forwarding : nil
 - Mode of Transport and Charges : FOR CTTC BBSR
 - Delivery Schedule : Delivery: Within 30 days of receipt of material.
 - Terms of Payment : Payment : Within 15 days of delivery and acceptance of items.

Date -

General Manager
Authorised Official

Central Tool Room & Training Centre
Bhubaneswar

PURCHASE ORDER

INDENT COPY



CENTRAL TOOL ROOM & TRAINING CENTRE

(A Government of India Society, Ministry of MSME)
B-36, CHANDKA INDUSTRIAL AREA, BHUBANESWAR - 751 024, ODISHA
Phone : Direct (0674) 3297116 (Purchase)
Fax : 91-674- 2743061, Email : cttc@satyam.net.in, Website : www.cttcbsr.co.in



M/s Gram Tarang Employability Training Services Private Limited
J.I.T.M. Campus, Aluri Nagar
R.Sitapur, Paralakhemundi - 761211
Ph No: +91 891 6587657 / 09437619974

Purchase/Work Order No.: - 1603009
Date: - 29.04.2016
Our Tender Enquiry No: - Enq by Prod. Committee(LT)
Date :- 27.04.2016
Your Ref. No.: - GTET/PKD/004
Date :- 23.04.2016
Indentor :- KVK

The undersigned is pleased to order the followings/accepts your tender mentioned above for supplies/services as detailed in the schedule below subject to terms and conditions mentioned under and over leaf herewith.

Sl. No.	Articles/Services to be supplied	Quantity	Unit	Unit Price Rs.	Amount Rs.
1	Bellow Support As per Our Enclosed Drawing - I Drawing No : 15 12 28 PD 02 01	650	Nos	150.00	97500.00
Other terms & condition as per enclosed Annex-I & attached Checklist for the supplier .					
Criteria of Acceptance: Sample to be Approved & CTTC Inspection Report					

Total in Words: (Rupees Ninety Seven Thousand Five Hundred Only) In Figures : 97,500.00

TERMS & CONDITIONS

- Sales Tax : Price inclusive of All Taxes (VAT should be shown separately)
- Excise Duty : nil
- Octroi Duty : nil
- Any other Taxes / Duties if any : nil
- Insurance : nil
- Packing / Forwarding : nil
- Mode of Transport and Charges : nil
- Delivery Schedule : Delivery - Within 30 Days of receipt of material.
- Terms of Payment : Payment - Within 15 days of acceptance of items

General Manager/
Authorised Official

Date -

Indentor's Signature
Date.....

PURCHASE ORDER

ORIGINAL COPY



CENTRAL TOOL ROOM & TRAINING CENTRE

(A Government of India Society, Ministry of MSME)

B-36, CHANDKA INDUSTRIAL AREA, BHUBANESWAR - 751 024, ODISHA

Phone : Direct (0674) 3011710 (Purchase)

Fax : 91-674-2743061, Email : ctcc@ctcc.gov.in, Website : www.ctccbbsr.co.in

ISO-9001, ISO-14001
OHSAS-18001
ISO-29990

M/s Gram Tarang Employability Training Services Private Limited
J.I.T.M Campus, Aluri Nagar, R.Sitapur
Paralakhemundi - 761211
Ph No: +91 891 6587657, 09437619974

Purchase/Work Order No.: - 1603075
Date 16.12.2016
Our Tender Enquiry No.: - TE-55 (LT)
Date :- 29.06.2016
Your Ref. No.: - nil
Date :- nil
Indentor :- A.Rashid

The undersigned is pleased to order the followings/accepts your tender mentioned above for supplies/services as detailed in the schedule below subject to terms and conditions mentioned under and over leaf herewith.

Sl. No.	Articles/Services to be supplied	Quantity	Unit	Unit Price		Amount	
				Rs.	P.	Rs.	P.
1	Machining of Components as per Enclosed annexure-I						226095.00
<p>Other terms & condition as per enclosed Annex-II & attached Checklist for the supplier</p> <p>Criteria of Acceptance: Approval of Sample & CTTC Inspection Report.</p> <p>Material shall be supplied by CTTC BBSR.</p>							

Total in Words : (Rupees Two Lakh Twenty Six Thousand Ninety Five Only)

226095.00

TERMS & CONDITIONS

1. Sales Tax :
2. Excise Duty :
3. Octroi Duty :
4. Any other Taxes / Duties if any :
5. Insurance :
6. Packing / Forwarding :
7. Mode of Transport and Charges :
8. Delivery Schedule
9. Terms of Payment

Price Inclusive of All Taxes (Taxes should be shown separately)

nil

nil

nil

nil

nil

nil

Delivery - Within 30 Days of receipt of material.

Payment - Within 30 days of delivery and acceptance of items

General Manager/
Authorised Official

Date -

PURCHASE ORDER

ORIGINAL COPY



CENTRAL TOOL ROOM & TRAINING CENTRE

(A Government of India Society, Ministry of MSME)

B-36, CHANDKA INDUSTRIAL AREA, BHUBANESWAR - 751 024, ODISHA

Phone : Direct (0674) 3011710 (Purchase)

Fax : 91-674-2743061, Email : cttc@cttc.gov.in, Website : www.cttcbbbsr.co.in

ISO-9001, ISO-14001
OHSAS-18001
ISO-29990

M/s Gram Tarang Employability Training Services Private Limited
J.I.T.M Campus, Aluri Nagar, R.Sitapur
Paralakhemundi - 761211
Ph No: +91 891 6587657, 09437619974

Purchase/Work Order No.: - 1703074
Date :- 07.08.2017
Our Tender Enquiry No.: - As per N.S. Approval
Date :- 06.12.2017
Your Ref. No.: - Nil
Date :- Nil
Indentor :- KVK

The undersigned is pleased to order the followings/accepts your tender mentioned above for supplies/services as detailed in the schedule below subject to terms and conditions mentioned under and over leaf herewith.

Sl. No.	Articles/Services to be supplied	Quantity	Unit	Unit Price		Amount	
				Rs.	P.	Rs.	P.
1	Machining of components as per enclosed annexure-I Material shall be supplied by CTTC BBSR. Other terms & condition as per enclosed Annex-II & attached Checklist for the supplier. Criteria of Acceptance: Approval of Sample & CTTC Inspection Report. OUR GST No: 21AAABC0056G1ZI As per GST rule two copies of invoice is to be furnished for release of payment.						578990.00

Total in Words (Rupees Five Lakh Seventy Eight Thousand Nine Hundred Ninety Only)

578990.00

TERMS & CONDITIONS

- Sales Tax : GST: As mentioned in annexure (GST to be shown separately)
- Excise Duty : nil
- Octroi Duty : nil
- Any other Taxes / Duties if any : nil
- Insurance : nil
- Packing / Forwarding : nil
- Mode of Transport and Charges : nil
- Delivery Schedule : nil
- Terms of Payment : Delivery - Within 30 Days of receipt of material.
Payment - Within 30 days of delivery and acceptance of items.

Date -

Managing Director/
Authorised Official

IRD IIT Delhi
IIT CAMPUS,HAUZ KHAS

PAYMENT ADVICE

To
Centurion University Of Technology And Management

Dear Sir/Madam,

Details of the transactions initiated through SBI CMP in favour of you are

PAYMENT_INVOICE_FIELDS	VALUES
UTR_NO	SBIN318211473835
AMOUNT	50,000.00
DATE	30-07-2018
LINKAGE_FIELD	
AMOUNT	50000
TAX DEDUCTED	
PROJECT NO	
OUT REF NO	
DATE	
GROSS AMOUNT	50000
TOWARDS	Participating Instt.
BANK NAME	Oriental Bank Of Commerce
ACCOUNT NO	16681131000056
IFSC CODE	ORBC0101668

Your Bank Account No: 16681131000056

Your Bank IFSC Code: ORBC0101668

Please acknowledge receipt of the payment
For IRD IIT Delhi

Authorised Signatory

This is Computer generated advice and does not require any Signature



Journal Voucher

No. : JV/01/91

Dated : 31-Jan-2018

Particulars		Amount	
	Organisation for Develop <i>Dr</i>	50,000.00	
	Integration & Social Action		
	<i>To</i> Grant in Aid (ODISA)		50,000.00
	ODISA- Impact Assessment 50,000.00 <i>Cr</i>		
On Account of :			
being the project cost reimbursement towards impact assessment for 2 projects is now accounted			
		Rs. 50,000.00	Rs. 50,000.00

Authorised Signatory

TERMS OF REFERENCE (ToR)

Impact Analysis Study of Project Structural Poverty Alleviation and Building up of Local Civil Bodies In Ganjam and Gajapati Districts, Odisha, India of Odisha State in India

I. Background

ODISA (Organization for Development Integration and Social Action) is the Social wing of the Vincentians, fathers and brothers of the North Indian Province of the Congregation of the Missions working in the South west of Odisha, the heartland of the Vincentians missionaries ever since their arrival from Spain in 1922. With formation of O.D.I.S.A in 1991 our role in addressing the basic needs of the poor shifted from a traditional "provider" to "facilitator". For the last 21 years O.D.I.S.A in collaboration with the different funding partners including MISEREOR intervened to bring the marginalized and deprived people into the mainstream development through different programs of income generation, capacity building and empowerment. In this process O.D.I.S.A learnt that the human power local bodies are basic to development activities.

There were also mission centres with essential infrastructure. ODISA used both, the contact and the infrastructural facilities as springboards for developmental activities. Although the project activities pivoted on Vincentian catholic missions, ODISA was inclusive in approach proper of its vision and mission addressing the needy irrespective of any religious affiliations. This was an added strength for ODISA sharing the credibility achieved by the Vincentians who are acclaimed as people always on the side of the poor throughout the project area. This is still being continued with all the area directors of the present project who are Vincentians.

This project under review is the 17th in the series of O.D.I.S.A –MISEREOR/KZE partnership. The project aimed to improve the life quality of Tribals, Dalits and women. These are groups of men and women marginalized, unorganized and living in poverty. The core mechanism of the project is a process in empowerment comprising all spheres of life, educational, social, economic and political.

ODISA assumes that poverty is attributable to the structures and its aggravation or alleviation depends on the existing structural functioning. Basically the structures are good and needed. What is important is their efficient and corruption-free functioning. Therefore ODISA wants to introduce a system forming community based organizations to serve as a watching and facilitating structure that ensures a free flow of the various development and welfare schemes to the ground reality of the poor. This way the poverty can be arrested and the life quality can be improved. This is workable because the Government has made policies and introduced programs to do away with poverty and bridge the gap between the rich and the poor. The development tools that ODISA employs are animation, awareness building and organization.

About Project "Structural Poverty Alleviation and Building up of Local Civil Bodies In Ganjam and Gajapati Districts, Odisha, India of Odisha State in India

II. "

a. Why we initiated this project?

The project aimed to improve the life quality of Tribals, Dalits and women. These are groups of men and women marginalized, unorganized and living in poverty. The core mechanism of the project is a process in empowerment comprising all spheres of life, educational, social, economic and political.

ODISA assumes that poverty is attributable to the structures and its aggravation or alleviation depends on the existing structural functioning. Basically the structures are good and needed. What is important is their efficient and corruption-free functioning. Therefore ODISA wants to introduce a system forming community based organizations to serve as a watching and facilitating structure that ensures a free flow of the various development and welfare schemes to the ground reality of the poor. This way the poverty can be arrested and the life quality can be improved. This is workable because the Government has made policies and introduced programs to do away with poverty and bridge the gap between the rich and the poor. The development tools that ODISA employs are animation, awareness building and organization.

Partners of this Project

O.D.I.S.A (Organization for Development Integration and Social Action), Ambapua Main Road, Berhampur Odisha, India is implementing partner of this project. MISEREOR/ KZE, as funding partner is providing the financial support for this project for effective implementation of this project.

Key Stakeholders

The Tribals, Dalits and women and these are groups of men and women marginalized, unorganized and living in poverty are the primary stakeholders in this project, whereas the Government duty bearers/officials – Including Block Development Officers, Rural Development Agencies and Odisha Livelihood Mission are considered as the secondary stakeholders.

III. Key Strategic focus and Specific objectives of the project :

This project aimed to achieve the following objectives

- 1) Marginalized people of 245 villages access to government programmes
- 2) 100% Dalit and Tribals receive and enjoy land entitlements and produce more crops by adopting organic and scientific agricultural process at the end of 3 years.
- 3) 50% Dalit, Tribal and women leaders participate in the electoral process and 75% women leaders contribute in the decision process within project period.
- 4) 269 leaders are strengthened on PRI and 466 local CBO leaders to demonstrate their roles and responsibility for systemic change of the local governance.

Specific objectives of this Project

The primary aim of "Structural Poverty Alleviation and Building up of Local Civil Bodies" project aimed to improve the life quality of Tribals, Dalits and women. These are groups of men and women marginalized, unorganized and living in poverty. The core mechanism of the project is a process in empowerment comprising all spheres of life, educational, social, economic and political.

IV. The main objectives of this Impact assessment study are to assess

- The Implementation processes and strategic interventions adopted
- The results, achievements and key changes that the project has brought about
- Consolidate and document the learning, challenges, strategies that have worked and good practices emerging out of the implementation experience of O.D.I.S.A

- Document the new opportunities for future programme intervention issues that may build a need base case for the continuity of this work.
- Review and document the status and impact on the Dalits, Tribals and Women and community level through the project intervention
- Assess the impact of the association with MISEREOR- KZE partnership strengthening, leveraging and visibility of O.D.I.S.A and vice-e-versa.
- Integration of all thematic areas in the project approach

These will be analyzed within the impact evaluation study, whether implementation of the project was effective and efficient and whether strengths of the implementing partners was utilized to the maximum level in strategic planning and effective implementation of the project.

This project has been a collaborative effort and has multiple stake holders. The impact evaluation will identify key challenges, successes, best practice and lessons learnt, to inform future collaborative interventions. It will consist of an evaluation of the effectiveness, efficiency and impact of project activities. Key lessons learnt can be used to shape the implementation strategy in the future for the implementing agency i.e. O.D.I.S.A

Scope of the assignment

The approach should examine the change and impact with respect to the short-term and long-term goals of holistic development of Vulnerable at different levels such as (1) Change in the life of Dalits, Tribals (2) Change at the Household level, (3) Change at the community and duty bearer level; specifically:

- 1) Before the project or the situation in year 2015
- 2) After the intervention of this **Structural Poverty Alleviation and Building up of Local Civil Bodies** project, or the situation during the intervention of this project.

Key Questions of the Impact Evaluation Study

Relevance

- To what extent **Structural Poverty Alleviation and Building up of Local Civil Bodies** project has taken in to account Dalits, Tribals and women different needs based on their socio-economic status and type of other vulnerabilities.
- How project was designed to meet the different needs of Dalits, Tribals and Women at large?
- Whether the most-vulnerable Dalits, Tribals and Women were targeted and reached through this project?
- To what extent were different stakeholders involved in needs assessment, design and implementation of project?
- Was the methodology used for the beneficiary selection relevant and done in participation of different stakeholders?
- What processes had been established in the project to address the issues of day-to-day project related issues and to what extent were they used?
- Are the Dalits, Tribals and Women active participants in social life?

Effectiveness

- Effectiveness in terms of appropriateness of the intervention, O.D.I.S.A's effectiveness in meeting the implementation timelines as per the project design and overall coordination
- Adaptability of the project in dealing with key challenges
- Effectiveness of accountability mechanisms including a review at different levels and different intervals of the immersing issues and information sharing with the appropriate authorities.
- Processes, Quality and cohesiveness of implementation of each activity at each stage (targeting distribution, monitoring, etc.)
- Whether any new/innovative methodologies/approaches were tried during implementation of the project, if yes what were those and what were the results? What lessons were learned and what recommendations made?
- Were legal entitlements and schemes met and laws and policies discussed and followed in the project?
- How well **Structural Poverty Alleviation and Building up of Local Civil Bodies** project has responded on mainstream/ensure inclusion of gender, equality, protection etc.
- Were the needs assessments, monitoring, evaluation systems and associated indicators appropriate to measure it?

Efficiency

- How value-for-money was this project and how could it have been made more cost-efficient?
- How has this knowledge and information on various components of this project utilized among different agencies working in this similar areas and how efficiently was it done during the one year of the project.

Impact

- What were intended and unintended impacts of the project?
- To what extent did this project contribute towards positive impacts on lives of Dalits, Tribals and Women and their families with respect to :
 - Impact on the exiting support they are getting
 - Impact on the future expected activities to be organized
 - Impact of the participation in the local self government.
- What were the key strategic areas which contributed towards a positive impact in the lives of targeted Dalits, Tribals and Women including their family members?
- Overall Impact of Intervention on Dalits, Tribals and Women, Peer groups as well as neighborhood communities
 - Quantitative analysis of interventions
 - Qualitative analysis of outcomes and expected impact

Other Issues

The impact evaluation study will assess the effectiveness of the following in meeting their aims/targets:

- Strategy design and expected outcomes
- Implementation of project monitoring functions
- Relevance and effect of other disability cross-cutting issues on implementation

O.D.I.S.A is having set of documents, data and information related to the project such as project proposal, Inception survey data, report, weekly, monthly and quarterly progress reports, Project MIS and other documents, since beginning of the project. It is expected to review, analyse and develop a thorough understanding of the project based on these documents before commencing the assessment process, which enable the assessors to determine what further information will be required. Desk research will be a foundation of whole process and it is expected that O.D.I.S.A is able to extract all key information through the process for facilitating and developing the report.

Preparation of Evaluation Tools and Approach

The assessors will work in coordination with the Director O.D.I.S.A prepare the necessary tools, finalise the approach and schedule the assessment. Detailed methodology, sample plan, tools and action plan will be submitted as inception report

Data Collection and Consultation with Key Informants

The evaluators will coordinate with the Director O.D.I.S.A undertake interviews and gathering data at a field level. The assessors will work with the other project staffs like Project manager and team leaders to synthesise and access this information, as well undertaking additional interviews and data gathering, based on the instruction of the Director O.D.I.S.A .

VII. Deliverables

The assignment is expected to be completed within 8 days of its initiation, including the submission of the final report. Following are the key deliverables for the assignment with its expected timelines.

Kindly refer the attached template for submitting the report. (Will share it by 20th January 2018)

Following deliverables are expected

- a. Detailed inception report ((will include the complete evaluation design including the scope, evaluation approach, methodology, indicators, survey design, interview protocols, timeline, budget and any other relevant factors.)
- b. Report of preliminary findings
- c. Draft report with analysis of data
- d. Final impact assessment report and knowledge product and entire data set
- e. Final presentation

VIII. Time line:

Initiation of study – 13th January, 2018

Draft report –18th January , 2018

Final report –20th January, 2018

IX. Key Documents:

- a. Project Proposal and Annexes;
- b. Baseline Survey data
- c. Weekly, monthly and quarterly quantitative and qualitative report
- d. Annual narrative report

- Project
- a. Detailed inception report ((will include the complete evaluation design including the scope, evaluation approach, methodology, indicators, survey design, interview protocols, timeline, budget and any other relevant factors.))
 - b. Report of preliminary findings
 - c. Draft report with analysis of data
 - d. Final impact assessment report and knowledge product and entire data set
 - e. Final presentation

VIII. Time line:

Initiation of study – 13th January, 2018

Draft report – 18th January, 2018

Final report – 20th January, 2018

IX. Key Documents:

- a. Project Proposal and Annexes;
- b. Weekly, monthly and quarterly quantitative and qualitative report
- c. Annual narrative report
- d. All the event/specific activity based reports
- e. Newspaper clippings

X. Eligibility criteria for the assessor

O.D.I.S.A is looking for an experienced consultant to carry out this assignment. The following are the key eligibility criteria:

- Consultant must have thorough understanding of social development issues reflected through high quality documentation of interventions of social development programs.
- A minimum of five years of experience of various documentation activities for various social development programs and organizations, exclusively focus on impact assessment.
- A proven track record in ensuring preparation of different impact stories, reports and other documents on various developmental.
- Excellent language proficiency in English and Odiya

Reporting & Coordination

The consultant will report to Fr. Subhasish Mandal, Director, O.D.I.S.A or any person designated by him for the task on all deliverables at agreed timelines.

Tentative Budget

The total consolidated budget should not exceed Rs. 25,000/- for this impact assessment study.

IRD IIT Delhi
IIT CAMPUS,HAUZ KHAS

PAYMENT ADVICE

To
Centurion University Of Technology And Management

Dear Sir/Madam,

Details of the transactions initiated through SBI CMP in favour of you are

PAYMENT_INVOICE_FIELDS	VALUES
UTR_NO	SBIN318211473835
AMOUNT	50,000.00
DATE	30-07-2018
LINKAGE_FIELD	
AMOUNT	50000
TAX DEDUCTED	
PROJECT NO	
OUT REF NO	
DATE	
GROSS AMOUNT	50000
TOWARDS	Participating Instt.
BANK NAME	Oriental Bank Of Commerce
ACCOUNT NO	16681131000056
IFSC CODE	ORBC0101668

Your Bank Account No: 16681131000056

Your Bank IFSC Code: ORBC0101668

Please acknowledge receipt of the payment
For IRD IIT Delhi

Authorised Signatory

This is Computer generated advice and does not require any Signature



Receipt Voucher

No. : m

Dated : 21-Apr-2016

Particulars	Amount
Account :	
Capital Grant (NSDC)	56,66,666.00
NSDC (Loan)	3,83,33,334.00
Grant in Aid (NSDC)	39,16,667.00
NSDC 39,16,667.00 Cr	
Through :	
OBC-14261131001547-(NSDC)	
On Account of :	
RTGS-NSDC India SBINR52016042 received from NSDC through RTGS towards Grant -in-Aid.	
Amount (in words) :	
INR Four Crore Seventy Nine Lakh Sixteen Thousand Six Hundred Sixty Seven Only	
	Rs. 4,79,16,667.00

Authorised Signatory



ଓଡ଼ିଶା ओडिशा ODISHA

G 550064

Undertaking on behalf of Centurion University of Technology and Management

I, Ashok Mishra, Registrar and authorised signatory and acting on behalf of Centurion University of Technology and Management ("Borrower"), a Private University constituted vide Centurion University of Technology and Management, Orissa Act, 2010 (Orissa Act 4 of 2010) vide Orissa Gazette (Extraordinary) Notification bearing No. 1355 dated August 27, 2010 and further came into force vide the Orissa Gazette (Extraordinary) Notification bearing No. 2161 dated December 23, 2010 and the Orissa Gazette (Extraordinary) Notification bearing No. 338 dated February 11, 2011, having its registered office at Village Alluri Nagar, PO: R Sitapur, Via: Uppalada, Paralakhemundi, Gajapati, Odisha, 761211 state and undertake as below.

That the Borrower will avail an assistance for an amount of Rs. 4,00,00,000 (Rupees Four Crores Only) as Loan ("Loan Amount") from National Skill Development Corporation ("NSDC"), a not for profit company, registered under the Companies Act, 1956 and licensed under section 25 of the Companies Act, 1956 having its registered office at A-Block, Clarion Collection, Shaheed Jeet Singh Marg, New Delhi-110016, India, on such terms and conditions as mentioned in the Loan Agreement dated March 03, 2016 ("Loan Agreement") executed between NSDC and the Borrower. That the said Assistance will be availed by the Borrower for the execution of the "Project" as described in detail in the Loan Agreement.

Conted..P/2

A Mishra

That based on the obligations arising upon the Borrower, I, on behalf of the Borrower do hereby further confirm, assure, declare and irrevocably undertake the following:

- (i) That the Borrower shall give notice along with agenda of all its meetings of the Board of Governors ("Board") to NSDC in the same manner as it is given to other members of the Board.
- (ii) That NSDC shall have the right to nominate any person to attend all the meetings of the Board.

Any failure by Borrower under this undertaking shall be termed as an Event of Default under the Loan Agreement and all consequent actions by NSDC as per terms of Loan Agreement accordingly shall follow. This undertaking shall be binding on the Borrower at all times.

For Centurion University of Technology and Management

A Mishra

Ashok Mishra
Registrar



Date: 30 March 2016

Place: Bhubaneswar

Witnessed by:

Name: Gunanidhi Das

Address: 21 Keshari Villa, Pokhariput
Bhubaneswar 751020

Signatures Gunanidhi Das

Witnessed by:

Name: Bijaya laxmi Behera

Address: Plot 11, Second Phase, Indraprastha
Pokhariput, Bhubaneswar 751020

Signatures Bijaya laxmi

TERM SHEET

Centurion University of Technology and Management (CUTM)
(Innovation)

November 25th, 2015



N · S · D · C
National
Skill Development
Corporation

Block A, Clarion Collection (Qutab Hotel),
Shaheed Jeet Singh Marg
New Delhi – 110016

1. Brief about the Project

Particular	Remarks			
Name of the Project	Centurion University of Technology and Management (CUTM)			
Proposing Organization	Centurion University of Technology and Management (CUTM) through a SBU			
Implementing Organization	Centurion University of Technology and Management (CUTM)			
Funding Details				
Total Project Cost	Rs. 6.00 Crores			
Promoter's contribution	Rs. 1.00 Crore			
NSDC Funding	Loan - Rs. 4.00 Crores, Grant- Rs 1.00 Crore			
NSDC investment per trainee	INR 2972			
Cost per trade per center	The project is to be executed through community resource persons with practical trainings at the farm level in naxalite effected areas; hence this is not applicable			
Project Details				
Project Duration	10 years			
Number of people to be trained	13,460			
Targeted Sectors	The training will be provided in Agriculture			
Target Trainee Segment	The project's target group includes the local youth and farmers with special focus on SC, ST and women.			
Target Trades: The applicant has proposed to promote organic agriculture along with training over the period of 10 year. The targeted sector & trades thereunder is given below:				
#	Sector	Trades	Average Fees (INR)	Average Course Duration
1	Agriculture	<ul style="list-style-type: none"> • Certificate course in Natural resource Management • Certificate course in Crop production • Certificate course in Crop Protection • Certificate course in harvesting and post-harvesting • Certificate course in community mobilisation • Certificate course in farmers' organisation formation • Certificate course in governance of community based organisation • Certificate course in project management 	<ul style="list-style-type: none"> • CRP Training- INR 8000 per trainee • Field Training- INR 5000 per trainee 	<ul style="list-style-type: none"> • 2 harvest cycles (2 months to 2 years)
2	Agribusiness	<ul style="list-style-type: none"> • Certificate course in agri-processing • Certificate course in input supply chain (fertiliser, pesticide, seed, irrigation, etc.) • Certificate course in agri-marketing 	<ul style="list-style-type: none"> • CRP Training- INR 8000 per trainee • Field Training- INR 5000 per trainee 	<ul style="list-style-type: none"> • 2 harvest cycles (2 months to 2 years)
3	Banking and Finance	<ul style="list-style-type: none"> • Certificate course in financial inclusion and financing 	<ul style="list-style-type: none"> • CRP Training- INR 8000 per 	<ul style="list-style-type: none"> • 2 harvest cycles (2

M.V. Mishra

Particular	Remarks
	trainee months to 2 years) • Field Training- INR 5000 per trainee
#The proposed courses are for improvement of the supply chain management and to economically uplift the marginal farmers in naxalite affected areas. The courses are yet to be QP mapped. The applicant has proposed that on approval of the project the courses will be aligned to NSQF.	
Revenue Model	Revenue would be generated from the following 3 heads, namely: <ul style="list-style-type: none"> • Training income • Sale of products • Contract manufacturing
Target Locations of the Project over 10 years	The project is proposed to cover the states of Odisha, Andhra Pradesh, Jharkhand, Bihar, West Bengal & Assam.
Target locations of the project for 1 st and 2 nd year	The applicant has proposed to start the project in Rayagada district of Odisha and Vizianagaram district of Andhra Pradesh in the first year & to scale up in other districts of South Odisha and North Coastal Andhra Pradesh in 2 nd year.
Number of centers	The plan has been designed for setting up training centres in 9 districts of East (South Odisha) and 3 Districts of South (North Coastal Andhra Pradesh) State. Also, it has been proposed to run satellite centres and provide practical trainings at the farm level.
Increase in income	Economic upliftment of the marginal farmers

M.V. Mishra

President
University of
Centurion Management

2. Operating Model

Particular	Details (key highlights only)
Structure (e.g.: Hub/Spoke, franchisee etc)	<p>The business model of the company include training of Community Resource Persons as Master Trainers who in turn will further train the farmers for making them practise sustainable agriculture.</p> <p>The applicant has proposed to target South Odisha and North Coastal Andhra Pradesh. The plan will be scaled up to 12 districts (9 in South Odisha and 3 in AP) from the initial 2 districts in the first year. The satellite centres will be setup in collaboration with our institutional partners</p> <p>The business model of society includes following stages of innovation for encouraging sustainable agriculture amongst farmers:</p> <ul style="list-style-type: none"> • Training and certification of CRP's • Training of farmers • Creation and development of supply chain and input and output services • Local production and consumption of organic nutrients and bio-pesticides • Development of market linked value added agriculture products. <p>The applicant has proposed to form and organize clusters in order to increase the bargaining power of farmers through long term contracts with suppliers and buyers. The society has also proposed to have a centralized lab facility for testing and continuous product and process development.</p>
Sourcing of trainees	<ul style="list-style-type: none"> • The society has provided that the trainees will be sourced from NGOs working in the area, partner organisations (BREDS and Harsha Trust), CSR initiatives of the companies working in the area, and Government sponsored development programs such Integrated Tribal development Program (ITDA), Odisha Tribal Empowerment and Livelihood Program (OTELP), National Rural Livelihood Mission (NRLM), Watershed Programs, etc.
Infrastructure	<ul style="list-style-type: none"> • The applicant has provided that the training will be imparted both at Head Office and Regional Centres. Training infrastructure will include agricultural implements, small scale bio-fertiliser and bio-pesticide production demonstration facilities, and portable equipment for GIS mapping etc. These facilities will be used for training of farmers at Regional Centres.
Type of training Delivery (e.g.: ILT, web based, VSAT etc)	<ul style="list-style-type: none"> • Training of CRPs (selected from progressive farmers). The content development for training the CRP's will be undertaken by CUTM's school of agriculture and school of management. There will be combination of class room learning and experiential learning in the farm field. The CRPs will be trained at the HO in the University • Training of Farmers - Training by CRPs about right package of practices. Field training would be conducted by CRPs for the farmers
Trainers	<ul style="list-style-type: none"> • As per the applicant, the company has proposed to hire trainers who are expert in their fields and have experience and intent to render remote training. For the trainers of CRP, the faculty members of the School of Agriculture Sciences, School of Management of the University, School of Engineering and Technology, School of Vocational Studies, School of Basic Sciences and School Social Sciences; experts from partner institutions (Gram Tarang, BREDS, Harsha Trust and Sri Sai Agri-bio labs) will be involved. Each of the trainers will be domain experts with long years of field level experience, besides mastery over theory and their education

M.V. Mishra

President

Particular	Details (key highlights only)
	qualifications, often, will be Master or PhD.
Content Development, updation and accreditation	<ul style="list-style-type: none"> The Content Development has been undertaken by CUTM's School of Agriculture and School of Management. This initial content will undergo further improvements and additions to reflect newer technologies, applications, products, etc. Appropriate faculty members from the various resources of the University will be used. Additionally, resource persons from the partner organisations will be part of the Content Development process.
Assessment & Certification	<ul style="list-style-type: none"> The Certification of CRPs and Farmers will follow the standard University protocol, including National Skill Qualification Framework (NSQF).
Placements	<ul style="list-style-type: none"> The trainees will be self-employed. Farmers can enhance their income through contract farming. CRPs can earn adequate revenue as a share from the CRP-induced savings of farmers. It will be from the input (purchase of bio-fertiliser, bio-pesticide, seed, irrigation, etc.) and output (sale of farm produce) services of farmers.
Competition	<ul style="list-style-type: none"> The applicant has provided that, bio-pesticides and bio-fertilizers have a short shelf-life, hence local manufacturers will have an edge over far away competitors and the proposal will not face any extreme competition in the market

M.V. Wiston

President
Centurion University of

3. About Promoter Group and Proposing/implementing entity

- Centurion University of Technology and Management (CUTM) was incorporated in 2010. CUTM has been created by an act of Odisha State Legislative Assembly and is a statutory Body.
- CUTM and its partners has long-years of experience in skill development in different parts of the country which includes curriculum development, master trainer development, training of trainers and training of end users. CUTM has also worked under various skill development schemes run by Govt. of India and has trained 14489 candidates under non-fee based model and 23540 candidates under fee-based model in last 7 years.

The Promoters of CUTM are as follows:-

- o Prof. Mukti Kanta Mishra – President
- o Prof. D N Rao - Vice President
- o Prof. D Nageswar Rao - Vice Chancellor
- o Prof. Ashok Mishra - Registrar

M. K. Mishra

President
Centurion University of
Technology & Management

4. Shareholding Structure – Centurion University of Technology and Management (CUTM)

Since CUTM is a private university formed under the State Act, hence shareholding is not applicable.

M.V. Mishra

President
Centurion University of
Technology & Management

5. Previous and Relevant Experience

SKILLING/TRAINING EXPERIENCE

No of Trainees	2014-15	2013-14	2012-13	2011-12	2010-11	2009-10	2008-09
CUTM Fee Based	5,292	4,497	3,965	3,638	2,450	1,972	1,726
Diploma	575	0	0	0	0	0	0
B Tech	3,828	3,686	3,535	3,272	2,323	1,897	1,655
MBA	170	199	210	151	51	75	71
Others	719	612	220	215	76	0	0
CUTM Non Fee Based	500	335	4,896	3,157	1,654	2,694	1,253
Gram Tarang Fee Based	4,004	1,566	2,315	2,459	1,542	377	343
Gram Tarang Non Fee Based	10,988	8,598	2,968	3,257	2,297		
No of Trainees (fee based)	9,296	6,063	6,280	6,097	3,992	2,349	2,069
No of Trainees (non - fee based)	11,488	8,933	7,864	6,414	3,951	2,694	1,253
No of Trainees Placed	11,619	7,874	7,634	6,211	3,570	1,996	1,037

M.V.C. Mishra
Centurion University of
Technology & Management

6. Promoters and management team

Name	Designation	Educational Qualification & Institute	Past Experience—Area and years
Prof. Mukti Kanta Mishra	President	PhD	More than 20 years in corporate, teaching and development.
Prof. D N Rao	Vice President	MBA	More than 20 years in corporate, teaching and development
Prof. D Nageswar Rao	Vice Chancellor	PhD	More than 35 years in corporate, teaching, research and training
Prof. Ashok Mishra	Registrar	PhD	More than 15 years in Teaching and research

M. C. Mishra
President of
Centurion University of
Technology & Management

7. Terms and Conditions of NSDC's Funding Assistance

Details of the NSDC Funding Assistance	Rs 400.00 Lakh as loan & 100.00 Lakh Grant from NSDC		
Promoters Contribution	Rs 100 Lakh only in the form of equity		
Moratorium & Repayment	Principal Moratorium Period: Two (2) years from the date of 1st disbursement Repayment Period: Ten (10) Years (including Moratorium Period) from the date of 1st disbursement		
Interest Rate	Nil		
Repayment Schedule	In 32 equal quarterly installments starting from Q1 Yr 3		
Collateral	<p>Mandatory Collateral</p> <ul style="list-style-type: none"> • First charge on assets of the project. • <u>First charge on cash flows of the project.</u> • Charge on IP of the project. <p>Additional Collateral</p> <ul style="list-style-type: none"> • Nil 		
Promoters Contribution	<p>Capital Infusion by promoters would be in the form of capital contribution (Rs)</p> <table border="1"> <tr> <td>Year 1</td> <td>10,000,000</td> </tr> </table>	Year 1	10,000,000
Year 1	10,000,000		
Project Specific Conditions	<ul style="list-style-type: none"> • Separate books of account shall be maintained for the proposed NSDC proposal. • Equipment and machinery cost funded from the project cannot be used for any commercial purpose either by CUTM or any of its associate or related firms/trusts/companies or such firms/trusts/companies (associate or related as defined by various statutes). If utilized for such purpose other than the project, NSDC shall have the right to recall the money and/or take any suitable action which NSDC may deem fit. • The disbursement for content development up gradation shall not be disbursed in a single tranche, but will be disbursed based on expenditure of earlier tranche. NSDC will conduct suitable audit/inspection of the same. • The promoter's contribution will be on matching basis in compliance with NSDC's funding guidelines and shall not be in kind. • Milestones will include the training of CRPs and Farmers and revenue from the sale of the products. NSDC reserves the right to audit / do inspection of the impact of the proposed project on economic conditions of the targeted group. In case the targeted objectives are not met or evidenced, NSDC reserves the right to take necessary action. <p>All NSDC mandatory collateral will be applicable</p>		
Pre Disbursement Conditions	Standard Pre-disbursement conditions apply.		
NDU	NA since it's a society.		
Note: NSDC's Standard Pre-Disbursement Conditions will be applicable			

M.V. Mishra
 President
 Cuttack University of
 Technology & Management

8. Milestones

Year on Year Social Milestones

Particulars	Yr 1	Yr 2	Yr 3	Yr 4	Yr 5	Yr 6	Yr 7	Yr 8	Yr 9	Yr 10
CRPs	20	40	40	40	120	120	120	120	120	120
Field Trainee	100	1,000	1,000	1,500	1,500	1,500	1,500	1,500	1,500	1,500

Target Geographies		The applicant targets the local youth and farmers with special focus on SC, ST and women.
Target Training Segment	Socio Economic background of candidates	
	Educational Background	
	Any special populations targeted	
	Gender Inclusion	

Pt. J. S. University of
 Nutrition & Management
 Technology
 M. V. Wistha

9. Disbursement and Utilization Schedule

(In Rs Lakhs)

Particulars	Yr 1
NSDC Loan	400
NSDC Grant	100
Promoter Contribution	100
Total Source of Funds	600
Capital Expenditure	540
Content Development Cost	50
Loss Funding	0
Working capital	10
Total Uses of funds	600

Location and Capital Expenditure of centres

Location Details

The project is proposed to cover the states of Odisha, Andhra Pradesh, Jharkhand, Bihar, West Bengal & Assam.

Capital expenditure on the setting up of centres:

(In Rs Lakhs)

Particulars	Year 1
Agricultural equipment and instruments	215
Harvest, postharvest and processing equipment	140
Bio fertiliser production equipment	175
Furniture and fixtures	5
IT Equipment	5
Content Development	50

M.V. Mishra

10. Repayment Schedule

(In Rs Lakhs)

		Principal Balance	Principal Repayment	Closing Balance	Interest Due	Interest Repayment	Total Repayment	Outstanding Interest
Year 1	Apr-Jun	400	0	400	0	0	0	
	July-Sep	400	0	400	0	0	0	
	Oct-Dec	400	0	400	0	0	0	
	Jan-Mar	400	0	400	0	0	0	
Year 2	Apr-Jun	400	0	400	0	0	0	
	July-Sep	400	0	400	0	0	0	
	Oct-Dec	400	0	400	0	0	0	
	Jan-Mar	400	0	400	0	0	0	
Year 3	Apr-Jun	400	12.5	387.5	0	0	12.5	
	July-Sep	387.5	12.5	375	0	0	12.5	
	Oct-Dec	375	12.5	362.5	0	0	12.5	
	Jan-Mar	362.5	12.5	350	0	0	12.5	
Year 4	Apr-Jun	350	12.5	337.5	0	0	12.5	
	July-Sep	337.5	12.5	325	0	0	12.5	
	Oct-Dec	325	12.5	312.5	0	0	12.5	
	Jan-Mar	312.5	12.5	300	0	0	12.5	
Year 5	Apr-Jun	300	12.5	287.5	0	0	12.5	
	July-Sep	287.5	12.5	275	0	0	12.5	
	Oct-Dec	275	12.5	262.5	0	0	12.5	
	Jan-Mar	262.5	12.5	250	0	0	12.5	
Year 6	Apr-Jun	250	12.5	237.5	0	0	12.5	
	July-Sep	237.5	12.5	225	0	0	12.5	
	Oct-Dec	225	12.5	212.5	0	0	12.5	
	Jan-Mar	212.5	12.5	200	0	0	12.5	
Year 7	Apr-Jun	200	12.5	187.5	0	0	12.5	
	July-Sep	187.5	12.5	175	0	0	12.5	
	Oct-Dec	175	12.5	162.5	0	0	12.5	
	Jan-Mar	162.5	12.5	150	0	0	12.5	
Year 8	Apr-Jun	150	12.5	137.5	0	0	12.5	
	July-Sep	137.5	12.5	125	0	0	12.5	
	Oct-Dec	125	12.5	112.5	0	0	12.5	
	Jan-Mar	112.5	12.5	100	0	0	12.5	
Year 9	Apr-Jun	100	12.5	87.5	0	0	12.5	
	July-Sep	87.5	12.5	75	0	0	12.5	
	Oct-Dec	75	12.5	62.5	0	0	12.5	
	Jan-Mar	62.5	12.5	50	0	0	12.5	
Year 10	Apr-Jun	50	12.5	37.5	0	0	12.5	
	July-Sep	37.5	12.5	25	0	0	12.5	
	Oct-Dec	25	12.5	12.5	0	0	12.5	
	Jan-Mar	12.5	12.5	0	0	0	12.5	
Total		0	400	-	0	0	400	-

COTM Other Bank File

ORIENTAL BANK OF COMMERCE

PAGE: 1
PP312602 1668

16.17

BRAGUL-JATAMI

Phone Nos: 98742491962

IFSC CODE:ORXC0101426 MICR CODE:751022000

TO:

DATE: 02-05-2016 15:56:59

M/S. CENTURION UNIVERSITY OF TECHNOLOGY AND MANAGEMENT NSDC

NOMINATION REGD WITH BANK: No

CUSTOMER ADDRESS:

H16-V PHASE-I BDR DUPLEX

POKHARIPUT

BHUBANESHWAR - 751020

ORISSA

INDIA

cfo@cotm.ac.in

ACCOUNT ADDRESS:

PLOT NO 136137 RAMCHANDRAPUR

POPS JATMI DISTT KHURDA

JATAMI-KHURDA - 752050

ORISSA

INDIA

2016-17
01 April 2016
To
31 May 2016

PRAGATI CURRENT A/C A/C NO ~~XXXXXXXXXX~~ INR STATEMENT OF ACCOUNT FOR THE PERIOD OF : 01-04-2016 to 31-05-2016

DATE	PARTICULARS	CHK. NO.	Dr. Amount (INR)	Cr. Amount (INR)	BALANCE
01-APR-2016	B/F				99,99,311.
02-Apr-2016	NEFT-OW/SAR33099429/UTKAL SEEDS AND NURSER	966751	1,50,000.00		98,49,311.
02-Apr-2016	Charges for NEFT Customer Payment :SAR3309		11.00		98,49,300.
06-Apr-2016	SANTOSH KUMAR BEHERA	966752	99,000.00		97,50,300.
09-Apr-2016	NEFT-OW/SAR33270206/AGARAM INDUSTRIES	966753	3,70,000.00		93,80,300.
09-Apr-2016	Charges for NEFT Customer Payment :SAR3327		29.00		93,80,271.
09-Apr-2016	NEFT-OW/SAR33270135/DAS AND KUMARS	966754	1,94,000.00		91,86,271.
09-Apr-2016	Charges for NEFT Customer Payment :SAR3327		11.00		91,86,260.
16-Apr-2016	NEFT-OW/SAR33409971/LAXMIDHAR SWAIN	966755	20,000.00		91,66,260.
21-Apr-2016	RTGSNSDC INDIASBINAS2016042128			1,79,16,667.00	5,70,82,322.
04-May-2016	NEFT-OW/SAR33811600/MAHAPATRA ENTERPRISES	966756	9,45,262.00		5,61,37,060.
04-May-2016	Charges for NEFT Customer Payment :SAR3381		29.00		5,61,37,031.
05-May-2016	NEFT-OW/SAR33860394/DHARU BIOTECH PVT LTD	966758	4,05,625.00		5,56,52,011.
05-May-2016	Charges for NEFT Customer Payment :SAR3386		29.00		5,56,51,982.
05-May-2016	NEFT-OW/SAR33867063/ENGINEERING MODELS AND	966757	31,492.00		5,56,20,490.
07-May-2016	NEFT-OW/SAR33897061/3 S ENTERPRISE	966759	2,53,978.00		5,53,56,512.
07-May-2016	Charges for NEFT Customer Payment :SAR3389		29.00		5,53,56,483.
09-May-2016	NEFT-OW/SAR33928810/PATRO AND CO	966760	50,000.00		5,53,06,483.
13-May-2016	NEFT BULK UPLD	966761	4,30,000.00		5,48,76,483.
16-May-2016	NEFT-OW/SAR34081610/LAXMIDHAR SWAIN	966762	40,000.00		5,48,36,483.
16-May-2016	BULK NEFT DATED 13-05-2016 RETURNED			4,30,000.00	5,52,66,483.
17-May-2016	DHARMA BEHERA	966765	1,70,000.00		5,50,96,483.
17-May-2016	NEFT-OW/SAR34109903/VAUGHAN MAHESWARA RAO	966763	1,30,000.00		5,49,66,483.
17-May-2016	Charges for NEFT Customer Payment :SAR3410		11.00		5,49,66,472.
17-May-2016	NEFT-OW/SAR34109951/RMIL KUMAR PADHE	966764	1,30,000.00		5,48,36,472.
17-May-2016	Charges for NEFT Customer Payment :SAR3410		11.00		5,48,36,461.
18-May-2016	DR. SAURAV JURNAN	966767	20,500.00		5,48,07,961.
18-May-2016	NEFT-OW/SAR34132090/ENGINEERING MODELS AND	966768	4,973.00		5,48,02,988.
18-May-2016	NEFT-OW/SAR34132562/RAND WINGS PRIVATE LIM	966766	1,00,000.00		5,47,02,988.
19-May-2016	NEFT-OW/SAR34160408/PATRO AND CO	966769	83,000.00		5,46,19,988.
20-May-2016	NEFT-OW/SAR34182427/MAHAPATRA ENTERPRISES	966770	34,810.00		5,45,85,978.
20-May-2016	NEFT-OW/SAR34182576/GLOBAL AGRI SYSTEM PVT	966771	90,000.00		5,44,95,978.
21-May-2016	AS PER LIST	966773	52,000.00		5,44,44,978.
24-May-2016	NEFT-OW/SAR34254632/SANTOSH KUMAR VARMA MU	966776	18,000.00		5,44,26,978.
24-May-2016	NEFT-OW/SAR34254445/S MOHAN RAO	966777	97,500.00		5,43,29,478.
27-May-2016	NEFT-OW/SAR34334538/PATRO AND CO	966778	30,000.00		5,43,09,478.
31-May-2016	RTGS-OW/ORBCH16152085539/GITA TRADING COMP	966902	3,70,125.00		5,39,29,353.
31-May-2016	Chrgs for RTGS Cust Pymnt:ORBCH16152085539		29.00		5,39,29,324.
Page Totals:			44,16,554.00	4,83,66,667.00	