



GRAM TARANG FOODS
PRIVATE LIMITED

CIN: U15549AP2009PTC064398
FY 2017-18



B-107, KSR Green Valley,
Madhavadhara, Visakhapatnam
Andhra Pradesh

GRAM TARANG FOODS PRIVATE LIMITED
NINTH ANNUAL REPORT
2017-18

BOARD OF DIRECTORS

Shashikant Tewary	-	Managing Director
D.N.Rao	-	Director

REGISTERED OFFICE

D-206, KSR Green Valley,
Madhavadhara, Visakhapatnam
Andhra Pradesh.

BANKERS

Andhra Bank

AUDITORS

SPC&Associates
Chartered Accountants

CONTENTS

- A G M Notice
- Directors' Report
- Auditors' Report
- Balance Sheet and Statement of Profit & Loss
- Notes forming part of Balance Sheet and Statement of Profit & Loss

NOTICE – SHAREHOLDERS
NINTH ANNUAL GENERAL MEETING

AGM Date	29 th September, 2018
Time	10.30 A.M.
Venue	Registered Office of the Company
	D-107, KSR Green Valley, Madhavadhara, Visakhapatnam Andhra Pradesh

ORDINARY BUSINESS:

1. To receive, consider and adopt the accounts of the company for the year ended 31st March, 2018 and the reports of the Directors and Auditors thereon.
2. To consider and if thought fit to pass the following resolution with or without modification as an ordinary resolution.

“RESOLVED THAT pursuant to the provision of section 139, 142 and other applicable provisions, if any, of the Companies Act, 2013 read with the underlying rules viz. Companies (Audit and auditors) Rules, 2014 as may be applicable and pursuant to the resolution passed by the members in the Annual General Meeting held on 29th September, 2018, the appointment of SPC & Associates, Chartered Accountants (FRN:005685S) as the auditors of the Company to hold office till the conclusion of the next AGM be and is hereby ratified and that the Board be and hereby authorized to fix the remuneration payable to them for the financial year ending March 31, 2019”

NOTES:

1. A member entitled to attend and vote at the meeting is also entitled to appoint a proxy to attend and vote instead of himself. A proxy need not be a member.
2. The proxy form duly completed and signed should be deposited at the Registered Office of the Company at least 48 hours before the commencement of the meeting.
3. Members are requested to notify immediately change of address, if any, to the Company’s registered office quoting their Registered Folio Number.

By Order of the Board

For **GRAM TARANG FOODS PRIVATE LIMITED**



Shashikant Tewary
Director (DIN: 06453360)

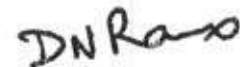

D.N.Rao
Director(DIN: 00939956)

Place: Vishakhapatnam
Date: 17th August, 2018

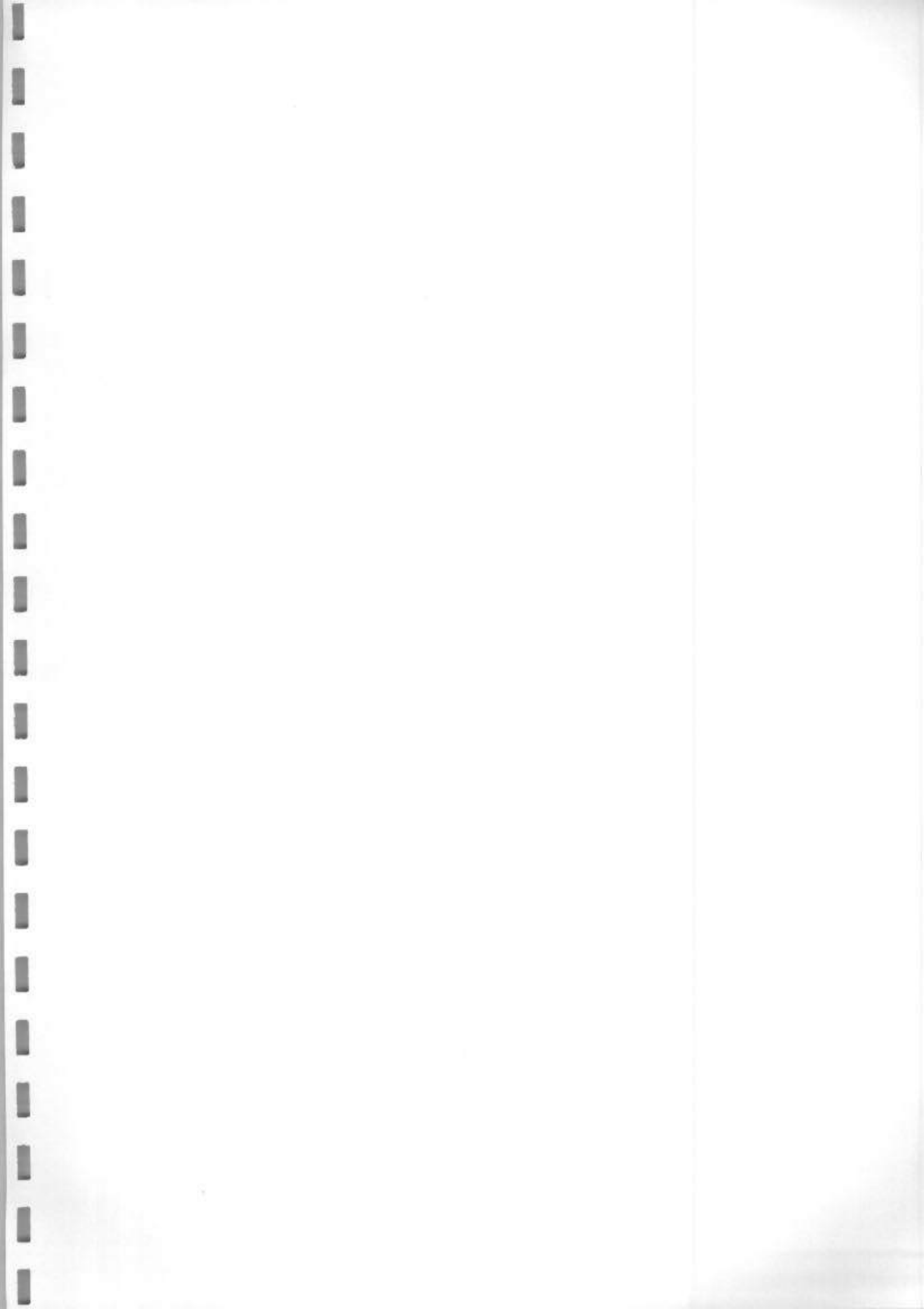

DIRECTORS' REPORT

To

**The Members,
Gram Tarang Foods Private Limited**

Your directors have pleasure in presenting their Ninth Annual Report on the business and operations of the company together with the Audited Statement of Accounts for the year ended 31st March, 2018.

A. Financial Highlights

During the year under review, performance of the company is as under:

(Amount in `)

Particulars	Year ended 31st March 2018	Year ended 31st March 2017
Total Income	1,70,10,746	1,58,92,177
Profit/(Loss) before taxation	17,84,570	31,25,088
<i>Less</i> : Tax Expense		
Current Tax :	33,052	5,95,458
Deferred Tax(Asset)/Liability :	(1,36,954)	(2,46,599)
Profit/(Loss) after tax	19,06,787	27,76,202
<i>Add</i> : Balance B/F from the previous year	(1,66,56,098)	(2,00,27,785)
Balance Profit / (Loss) C/F to the next year	(1,47,49,311)	(1,66,56,098)

B. State of Company's Affairs and Future Outlook

The Company deals in the business of manufacturing and processing of food products. However, due to lack of market potential, it has been incurring losses.

C. Change in nature of business, if any

There is no change in the nature of business of the company.

D. Dividend

The directors of the company have not recommended any dividend for the year ended 31st March, 2018.

E. Amounts Transferred to Reserves

There are no transfers made to the reserves during the year.

F. Changes in Share Capital, if any

There is no change in share capital during the year.

Disclosure regarding Issue of Equity Shares with Differential Rights

Not Applicable.

Disclosure regarding issue of Employee Stock Options

Not Applicable.

Disclosure regarding issue of Sweat Equity Shares

Not Applicable.

G. Extract of Annual Return

The extract of Annual Return, in format MGT-9, for the Financial Year 2017-18 has been enclosed with this report.

H. Number of Board Meetings

During the Financial Year 2017-18, 4 meetings of the Board of Directors of the company were held.

Particulars	Date of the Board meeting
Review the Financial Performance	16 th June, 2017
Approval of Financials of FY 2016-17	30 th August, 2017
Review the Business Operations	26 th November, 2017
Review the Financial Performance	12 th February, 2018

I. Particulars of Loan, Guarantees and Investments under Section 186

The Company does not have any loans, guarantees and investments covered under section 186 of the Companies Act, 2013.

J. Particulars of Contracts or Arrangements with Related Parties

The particulars referred above as per section 188 of the Act in accordance with the Rule 8 of the Companies (Accounts) Rules, 2014 is attached to this report.

K. Explanation to Auditor's Remarks

The Auditors' Report to the Members does not contain any qualifications, reservations or adverse remarks.

L. Material Changes Affecting the Financial Position of the Company

There are no material changes and commitments, affecting the financial position of the Company between the end of the financial year and the date of this report.

M. Conservation of Energy, Technology, Absorption, Foreign Exchange Earnings and Outgo

a) Conservation of Energy : N.A.

b) Technology Absorption

A) Research and Development (R&D) : Nil

B) Technology Absorption and Innovation : Nil

c) Foreign Exchange Earnings and Out go

Earnings : Nil

Out go : Nil

N. Details of Subsidiary, Joint Venture or Associates

During the year, no companies have become or ceased to be its subsidiaries, joint ventures or associate companies

O. Risk Management Policy

The board has not identified any such risk which may threaten the existence of the company.

P. Details of Directors and Key Managerial Personnel

No Directors have been appointed or resigned during the year.

Q. Details of significant & material orders passed by the regulators or courts or tribunal

There are no such orders passed during the current financial years.

R. Voluntary Revision of Financial Statements or Board's Report

No voluntary revision of Financial Statements or Board's Report in respect of any of the 3 preceding financial years has been made.

S. Re-appointment of Independent Auditor

Pursuant to Section 139 and other applicable provisions, if any, of the Companies Act, 2013, SPC&Associates, Chartered Accountants, are proposed to be ratified as the Statutory Auditors in the ensuing Annual General Meeting.

T. Disclosures under Sexual Harassment of Women at Workplace (Prevention, Prohibition & Redressal) Act, 2013

There are no such cases filed during the Financial Year.

U. Fraud Reporting (Required by Companies Amendment Bill, 2014)

The board has not identified any frauds.

V. Statutory Auditors

Pursuant to Section 139 and other applicable provisions, if any, of the Companies Act, 2013, SPC&Associates, Chartered Accountants, are proposed to be re-appointed as the Statutory Auditors in the ensuing Annual General Meeting.

W. Directors Responsibility Statement

In accordance with the provisions of Section 134(5) of the Companies Act 2013, your directors confirm that:

- a) in the preparation of the annual accounts for the financial year ended 31st March, 2018, the applicable accounting standards had been followed along with proper explanation relating to material departures;
- b) the directors had selected such accounting policies and applied them consistently and made judgments and estimates that are reasonable and prudent so as to give a true and fair view of the state of affairs of the Company as at 31st March, 2018 and of the profit of the Company for that period;

c) the directors had taken proper and sufficient care for the maintenance of adequate accounting records in accordance with the provisions of the Companies Act 2013 for safeguarding the assets of the company and for preventing and detecting fraud and other irregularities;

d) the directors had prepared the annual accounts on a going concern basis;

e) the directors had devised proper systems to ensure compliance with the provisions of all applicable laws and that such systems were adequate and operating effectively.

X. Acknowledgment

The Directors express their sincere appreciation to the valued shareholders, bankers and clients for their support.

For and on behalf of the Board of Directors
Gram Tarang Foods Private Limited



Shashikant Tewary
Managing Director (DIN: 06453360)

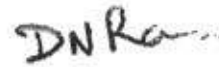

D.N.Rao
Director (DIN: 00939956)

Place: Vishakhapatnam
Date: 17th August, 2018

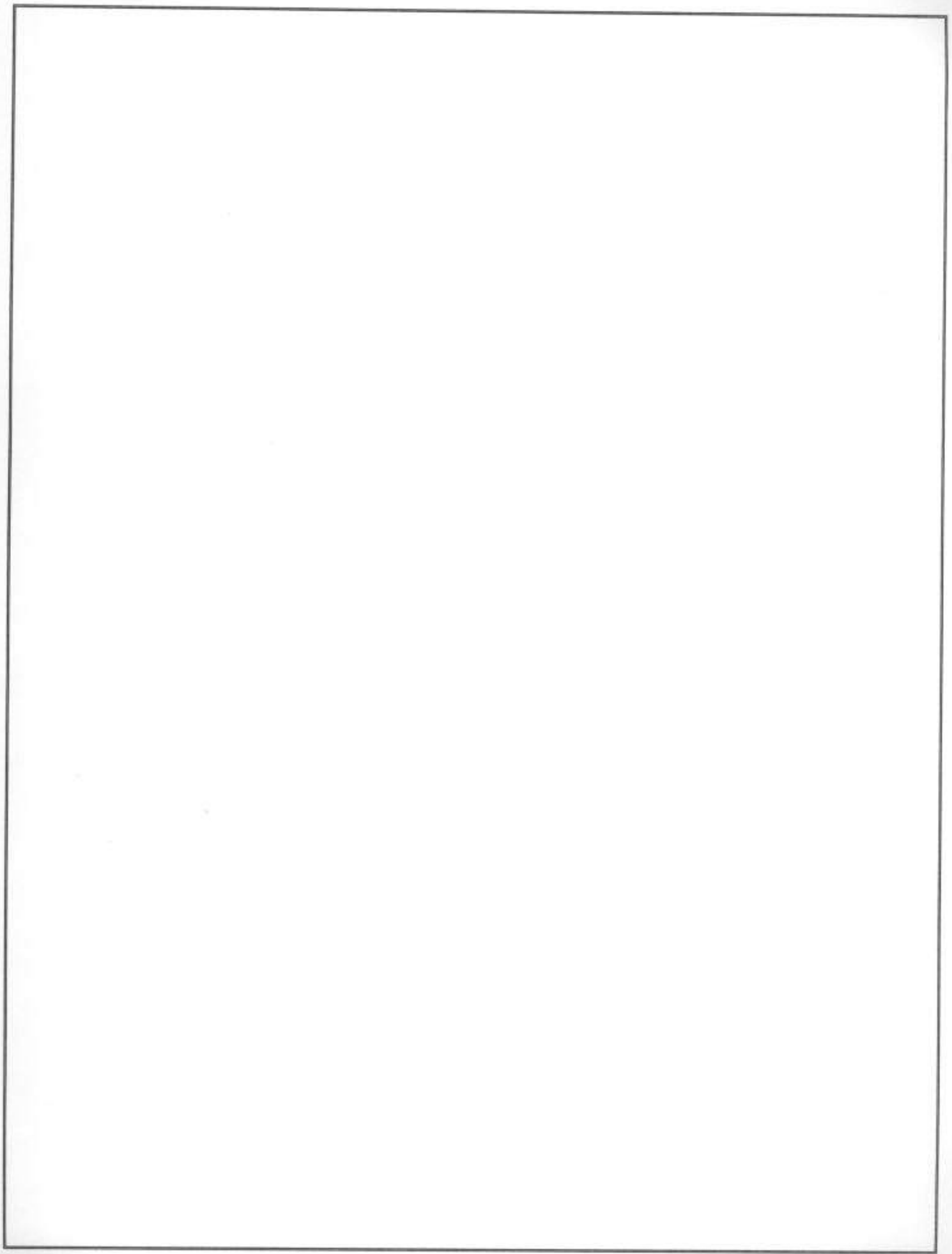

NOTES TO ACCOUNTS

NOTE: 28

SIGNIFICANT ACCOUNTING POLICIES:

A. Basis of Accounting

The accounts of the company are prepared & maintained consistently on accrual basis and under the historic cost convention and in accordance with the generally accepted accounting principles in India and in compliance with the applicable Accounting Standards issued by the Institute of Chartered Accountants of India as per Section 133 and relevant provisions of the Companies Act, 2013, except otherwise stated.

All assets and liabilities have been classified as current or non-current as per the Company's normal operating cycle and other criteria set out in the Schedule III to the Companies Act, 2013.

B. Fixed Assets

Fixed Assets are stated at cost (cost includes acquisition cost, freight, installation cost, finance cost, duties and taxes and other incidental expenses incurred during the construction/installation).

C. Depreciation

Depreciation on Fixed Assets is provided on the Written Down Value Method, as per the useful life of the assets given in the Schedule II to the Companies Act, 2013; and in the opinion of the management these rates reflect the estimated useful life of those assets. The Company estimates the scrap value of the assets to be 5% of the cost.

D. Revenue Recognition

Income is accounted for on the basis of products sold and billed to customers.

E. Earnings per share:

Basic earnings per share is computed by dividing the profit/ (loss) after tax (including the post-tax effect of extraordinary items, if any) by the weighted average number of equity shares outstanding during the year.

F. Provisions and Contingencies

A provision is recognized when the Company has a present obligation as a result of past events and it is probable that an outflow of resources will be required to settle the obligation in respect of which a reliable estimate can be made. Provisions are not discounted to their present value and are determined based on the best estimate required to settle the obligation at the Balance Sheet

date. These are reviewed at each Balance Sheet date and adjusted to reflect the current best estimates. Contingent liabilities are disclosed in the Notes.

G. Income Tax

The Company provides for and determines the current tax as the amount of tax payable in respect of the total income for the period. The Company recognizes and provides for the deferred tax on timing differences between total income and accounting income subject to the concept of prudence.

H. Cash and Cash equivalents

Cash comprises cash on hand and demand deposits with banks. Cash equivalents are short-term balances (with an original maturity of three months or less from the date of acquisition), highly liquid investments that are readily convertible into known amounts of cash and which are subject to insignificant risk of changes in value.

For SPC&Associates
Chartered Accountants
FRN: 005685S

for and on behalf of Board of Directors
GRAM TARANG FOODS PRIVATE LIMITED



CA Shravan kumar Reddy
Partner
MRN: 241004



Shashikant Tewary
Managing Director
(DIN: 06453360)



D.N.Rao
Director
(DIN: 00939956)

Date: 17th August, 2018
Place: Vishakhapatnam

Form No. AOC-2

(Pursuant to clause (b) of sub-section (3) of section 134 of the Act and Rule 8(2) of the Companies (Accounts) Rules, 2014)

Form for disclosure of particulars of contracts/arrangements entered into by the company with related parties referred to in sub-section (1) of section 188 of the Companies Act, 2013 including certain arm's length transactions under third proviso thereto.

1. Details of contracts or arrangements or transactions not at arm's length basis

(a) Name(s) of the related party and nature of relationship	Not Applicable
(b) Nature of contracts/ arrangements/ transactions	
(c) Duration of the contracts / arrangements/transactions	
(d) Salient terms of the contracts or arrangements or transactions including the value, if any	
(e) Justification for entering into such contracts or arrangements or transactions	
(f) Date(s) of approval by the Board	
(g) Amount paid as advances, if any:	
(h) Date on which the special resolution was passed in general meeting as required under first proviso to section 188	

2. Details of material contracts or arrangement or transactions at arm's length basis

(a) Name(s) of the related party and nature of relationship	Not Applicable
(b) Nature of contracts/ arrangements/ transactions	
(c) Duration of the contracts / arrangements/transactions	
(d) Salient terms of the contracts or arrangements or transactions including the value, if any	
(e) Date(s) of approval by the Board	
(f) Amount paid as advances, if any:	

GRAM TARANG FOODS PRIVATE LIMITED

CIN :U15549AP2009PTC064398

BALANCE SHEET AS AT 31st March, 2018

Particulars	Note No.	Amount in ₹	
		Figures at the end of	
		31-Mar-18	31-Mar-17
I. EQUITY AND LIABILITIES			
(1) Shareholder's Funds			
(a) Share Capital	1	52,50,000	52,50,000
(b) Reserves and Surplus	2	(1,24,99,312)	(1,44,06,099)
(2) Non-Current Liabilities			
(a) Long-Term Borrowings	3	1,95,00,250	2,38,79,175
(b) Deferred Tax Liabilities (Net)	4	(1,44,494)	(7,540)
(3) Current Liabilities			
(a) Short-Term Borrowings			
(b) Trade Payables	5	42,49,289	22,05,243
(c) Other Current Liabilities	6	1,17,90,683	1,36,88,843
(d) Short-Term Provisions	7	51,952	6,36,885
Total Equity & Liabilities		2,81,98,368	3,12,46,507
II.ASSETS			
(1) Non-Current Assets			
(a) Fixed Assets			
(i) Tangible Assets	8	1,87,78,381	2,24,26,802
(ii) Intangible Assets		5,48,388	7,59,652
(b) Long term loans and advances	9	1,93,26,770	2,31,86,455
		9,22,166	9,03,850
(2) Current Assets			
(a) Inventories	10	43,46,962	36,77,125
(b) Trade receivables	11	27,60,820	21,32,105
(c) Cash and cash equivalents	12	2,45,754	1,10,553
(d) Short-term loans and advances	13	5,95,897	12,36,420
Total Assets		2,81,98,368	3,12,46,507
Accounting Policies and other Notes to Accounts	24-30		

As per our report of even date attached.

For SPC&Associates

Chartered Accountants

FRN : 005685S

CA Shравan Kumar Reddy

Partner

MRN:240014

Place: Vishakhapatnam

Date: 17-08-2018

GRAM TARANG FOODS PRIVATE LIMITED

Shashikant Tewary
Managing Director
DIN : 6453360

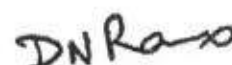
D.N.Rao
Director
DIN: 00939956

GRAM TARANG FOODS PRIVATE LIMITED
CIN :U15549AP2009PTC064398
PROFIT & LOSS STATEMENT FOR THE YEAR ENDED ON 31st March, 2018

Sr. No	Particulars	Note No.	Amount in ₹	
			Figures for the year ended	
			31-Mar-18	31-Mar-17
I	Revenue from operations	14	1,58,70,554	98,47,690
II	Other Income	15	11,40,192	60,44,487
	III. Total Revenue (I +II)		1,70,10,746	1,58,92,177
IV	Expenses:			
	Cost of materials consumed	16	53,83,650	55,72,652
	Changes in inventories of finished goods, work-in-progress and Stock-in-Trade	17	(5,44,074)	(25,28,883)
	Employee Benefit Expense	18	13,57,930	7,79,204
	Financial Costs	19	11,03,539	23,84,378
	Depreciation and Amortization Expense	20	38,65,131	47,21,132
	Other Administrative Expenses	21	40,60,000	18,38,607
	Total Expenses (IV)		1,52,26,176	1,27,67,089
V	Profit/(Loss) before exceptional and extraordinary items and tax	(III - IV)	17,84,570	31,25,088
VI	Exceptional Items		-	-
VII	Profit/(Loss) before extraordinary items and tax (V - VI)		17,84,570	31,25,088
VIII	Extraordinary Items		-	-
IX	Profit / (Loss) before tax (VII - VIII)		17,84,570	31,25,088
X	Tax expense:			
	(1) Current tax		33,052	5,95,485
	(2) Deferred tax		(1,36,954)	(2,46,599)
	(3) MAT Credit		(18,316)	(5,95,485)
XI	Profit/(Loss) from the period from continuing operations	(IX-X)	19,06,787	33,71,687
XII	Profit/(Loss) from discontinuing operations		-	-
XIII	Tax expense of discounting operations		-	-
XIV	Profit/(Loss) from Discontinuing operations (XII - XIII)		-	-
XV	Profit/(Loss) for the period (XI + XIV)		19,06,787	33,71,687
XVI	Earning per equity share:	22		
	(1) Basic		3.63	(10.27)
	(2) Diluted		3.63	(10.27)
Accounting Policies and other Notes to Accounts		24-30		

As per our report of even date attached.

For SPC&Associates
Chartered Accountants

FRN : 0056855

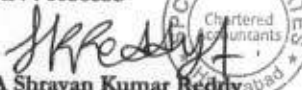
CA Shravan Kumar Reddy

Partner

MRN:240014

Place: Vishakhapatnam

Date: 17-08-2018

GRAM TARANG FOODS PRIVATE LIMITED

Shashikant Tewary
Managing Director
DIN : 6453360

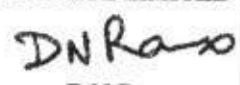

D.N.Rao
Director
DIN: 00939956

GRAM TARANG FOODS PRIVATE LIMITED
CIN :U15549AP2009PTC064398
CASH FLOW STATEMENT FOR THE YEAR ENDED 31.03.2018

Particulars	31-Mar-18	31-Mar-17
Cash Flow from Operating Activities		
Net Profit before Taxation and extraordinary items	17,84,570	31,25,088
Adjustments for:		
Depreciation and Amortisation	38,65,131	47,21,132
Interest debited to P&L	10,91,814	23,61,378
Operating Profit before Working Capital Changes	67,41,514	1,02,07,598
Working Capital Changes		
(Increase)/Decrease in Current Assets		
(Increase)/Decrease in Short term loans and advances	6,40,523	(10,17,200)
(Increase)/Decrease in Inventories	(6,69,837)	(20,86,735)
(Increase)/ Decrease in Trade Receivables	(6,28,715)	(16,91,188)
(Increase)/ Decrease in Other Current Assets	-	-
(Increase)/Decrease in Current Liabilities		
Increase/(Decrease) in Short Term Borrowings	-	(50,53,065)
Increase/ (Decrease) in Provisions	(6,17,985)	6,04,475
Increase/ (Decrease) in Other Current Liabilities	(18,98,160)	1,05,12,524
Increase/ (Decrease) in Trade Payables	20,44,046	(43,03,937)
Cash generated from operations	56,11,386	71,72,472
Net Cash Flow from Operating Activities	56,11,386	71,72,472
Cash Flow from Investing activities		
Purchase of Fixed Assets	(5,446)	-
(Increase)/ Decrease in Long term loans and advances	(18,316)	(5,95,485)
Net Cash Flow from Investing Activities	(23,762)	(5,95,485)
Cash Flow from Financing activities		
Increase in Share Capital	-	-
Security Premium received	-	-
Share Application money received	-	-
Decrease in long term borrowings	(43,60,609)	(43,37,683)
Interest Debited to P&L a/c	(10,91,814)	(23,61,378)
Net Cash Flow from Financing Activities	(54,52,423)	(66,99,061)
Net Increase or decrease in cash and cash equivalents	1,35,201	(1,22,075)
Increase or decrease in cash and cash equivalents	1,35,202	(1,22,074)
Add: Cash and cash equivalents at the beginning of the period	1,10,553	2,32,627
Cash and cash equivalents at the end of the period	2,45,754	1,10,553

As per our report of even date attached.

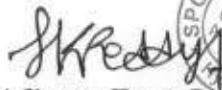
For SPC&Associates
Chartered Accountants
FRN : 005685S

CA Shravan Kumar Reddy
Partner
MRN:240014

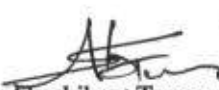

For GRAM TARANG FOODS
PRIVATE LIMITED

Shashikant Tewary
Managing Director
DIN : 6453360

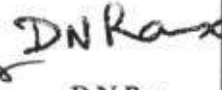
D.N.Rao
Director
DIN: 00939956

Place: Vishakhapatnam
Date: 17-08-2018

GRAM TARANG FOODS PRIVATE LIMITED
Notes Forming Integral Part of Financial Statements

Note: 1 Share Capital

S.No	Particulars	Amount in ₹	
		31-Mar-18	31-Mar-17
1	AUTHORIZED CAPITAL 10,00,00 Equity Shares of Rs. 10/- each.	1,00,00,000	1,00,00,000
2	ISSUED, SUBSCRIBED & PAID UP CAPITAL 5,25,000 Equity Shares of Rs. 10/- each Fully Paid up	52,50,000	52,50,000
	Total	52,50,000	52,50,000

a) Rights, preferences and restrictions attached to shares:

The company has one class of equity shares having a par value of ₹.10 per share. Each shareholder is eligible for one vote per share held. In the event of liquidation, the equity shareholders are eligible to receive the remaining assets of the Company after distribution of all preferential amounts, in proportion to their shareholding.

b) Details of Shares held by each shareholder holding more than 5% shares:

S.No	Name	Class of Share	Year Ended 31-Mar-18		Year Ended 31-Mar-17	
			No. of Share Holding	% of Holding	No. of Share Holding	% of Holding
1	Mukti Kanra Mishra	Equity shares fully paid up	118334	22.54%	118334	22.54%
2	DN Rao	Equity shares fully paid up	168333	32.06%	168333	32.06%
3	Shashikanth Tewary	Equity shares fully paid up	163333	31.11%	163333	31.11%
4	Supriya Patanaik	Equity shares fully paid up	50000	9.52%	50000	9.52%

c) Reconciliation of the number of shares and amount outstanding at the beginning and at the end of the period:

S.No	Particulars	Equity Shares	
		Year Ended 31-Mar-18	Year Ended 31-Mar-17
1	Opening Balance	5,25,000	5,25,000
2	Add/Less: Change During the Year	-	-
3	Closing Balance	5,25,000	5,25,000

GRAM TARANG FOODS PRIVATE LIMITED
Notes Forming Integral Part of Financial Statements

Note: 2 Reserve & Surplus

		Amount in ₹	
S No	Particulars	31-Mar-18	31-Mar-17
I	Securities Premium		
1	Premium on issue of shares	22,50,000	22,50,000
	Total(A)	22,50,000	22,50,000
II	Surplus		
1	Opening balance	(1,66,56,098)	(2,00,27,785)
2	Add: Profit / (Loss) for the year	19,06,787	33,71,687
3	Less: Depreciation written off	-	-
	Total(B)	(1,47,49,311)	(1,66,56,098)
	Total	(1,24,99,311)	(1,44,06,098)

Note: 3 Long Term Borrowings

		Amount in ₹	
S No	Particulars	31-Mar-18	31-Mar-17
1	Term Loan from Banks and Financial Institutions		
	From Bank from Andhra Bank	42,87,424	86,66,349
2	Unsecured Loans		
	Loans from Directors and relatives	1,37,12,826	1,37,12,826
3	GTET	-	-
4	GTIDS	15,00,000	15,00,000
	Total	1,95,00,250	2,38,79,175

Note: 4 Deferred Tax Liability (Net)

		Amount in ₹	
S No	Particulars	31-Mar-18	31-Mar-17
1	Deferred Tax Liability		
	Opening Balance	(7,540)	2,39,059
	Add: Current year (Asset)/Liability	(1,36,954)	(2,46,599)
	Total	(1,44,494)	(7,540)

Disclosures:

In accordance with the Accounting Standard (AS-22) on "Accounting for Taxes on Income" issued by the Institute of Chartered Accountants of India, the Company has created deferred Tax Asset arising out of the timing differences between taxable and book profits. Due to lack of reasonable certainty of taxable income in subsequent periods, the Company has not accounted for deferred tax asset arising on account of the timing difference.

GRAM TARANG FOODS PRIVATE LIMITED
Notes Forming Integral Part of Financial Statements

Note: 2 Reserve & Surplus

Amount in ₹

S No	Particulars	31-Mar-18	31-Mar-17
I	Securities Premium		
1	Premium on issue of shares	22,50,000	22,50,000
	Total(A)	22,50,000	22,50,000
II	Surplus		
1	Opening balance	(1,66,56,098)	(2,00,27,785)
2	Add: Profit /(Loss) for the year	19,06,787	33,71,687
3	Less: Depreciation written off	-	-
	Total(B)	(1,47,49,311)	(1,66,56,098)
	Total	(1,24,99,311)	(1,44,06,098)

Note: 3 Long Term Borrowings

Amount in ₹

S No	Particulars	31-Mar-18	31-Mar-17
1	Term Loan from Banks and Financial Institutions		
	From Bank from Andhra Bank	42,87,424	86,66,349
2	Unsecured Loans		
	Loans from Directors and relatives	1,37,12,826	1,37,12,826
3	GTET	-	-
4	GTIDS	15,00,000	15,00,000
	Total	1,95,00,250	2,38,79,175

Note: 4 Deferred Tax Liability (Net)

Amount in ₹

S No	Particulars	31-Mar-18	31-Mar-17
1	Deferred Tax Liability		
	Opening Balance	(7,540)	2,39,059
	Add: Current year (Asset)/Liability	(1,36,954)	(2,46,599)
	Total	(1,44,494)	(7,540)

Disclosures:

In accordance with the Accounting Standard (AS-22) on "Accounting for Taxes on Income" issued by the Institute of Chartered Accountants of India, the Company has created deferred Tax Asset arising out of the timing differences between taxable and book profits. Due to lack of reasonable certainty of taxable income in subsequent periods, the Company has not accounted for deferred tax asset arising on account of the timing difference.

GRAM TARANG FOODS PRIVATE LIMITED
Notes Forming Integral Part of Financial Statements

Note: 5 Trade Payables

Amount in ₹

S No	Particulars	31-Mar-18	31-Mar-17
1	Sundry Creditors	42,49,289	22,05,243
	Total	42,49,289	22,05,243

Note: 6 Other Current Liabilities

Amount in ₹

S No	Particulars	31-Mar-18	31-Mar-17
1	CST Payable	-	88,729
2	GST Payables	73,595	-
3	Service tax payable	-	13,71,428
4	TDS Payable	44,761	22,856
5	Advances	24,75,050	28,42,246
6	Advances to staff	800	-
7	Rent Received in Advance	78,28,572	88,80,001
8	Salary Payable	12,86,586	60,890
9	VAT Payable	0	3,74,831
10	Telephone Charges Payable	1,062	-
11	Electricity charges payable	80,257	47,862
	Total	1,17,90,683	1,36,88,843

Note: 7 Short Term Provisions

Amount in ₹

S No	Particulars	31-Mar-18	31-Mar-17
1	Provision for Income Tax	33,052	5,95,485
2	Audit Fees Payable	18,900	41,400
	Total	51,952	6,36,885

GRAM TARANG FOODS PRIVATE LIMITED
Notes Forming Part of Financial Statements

Note: 8 Fixed Assets

S No	Particulars	Gross Block				Depreciation			Net Block	
		Value at the beginning	Addition during the year	Deduction during the year	Value at the end	Value at the beginning	Addition during the year	Adjustment to Retained Earnings	Value at the end	WDV at the beginning of the year
I	Tangible Assets									
1	Land	2,55,289	-	-	2,55,289	-	-	-	2,55,289	2,55,289
2	Building	92,36,037	-	-	92,36,037	4,77,762	-	-	45,44,381	50,22,143
3	Plant and Machinery	3,80,58,866	-	-	3,80,58,866	31,67,868	-	-	1,39,67,758	1,71,35,626
4	Office Equipment	70,061	5,446	-	75,507	8,237	-	-	9,762	12,553
5	Others									
	Computers & Laptops	72,939	-	-	72,939	-	-	-	1,191	1,191
	SUB TOTAL (A)	4,76,93,192	5,446	-	4,76,98,638	36,53,867	-	-	1,87,78,381	2,24,26,802
II	Intangible Assets									
1	Technical Know How	22,86,863	-	-	22,86,863	2,11,264	-	-	5,48,388	7,59,652
	SUB TOTAL (B)	22,86,863	-	-	22,86,863	2,11,264	-	-	5,48,388	7,59,652
	Total [A + B] (Current Year)	4,99,80,055	5,446	-	4,99,85,501	38,65,131	-	-	1,93,26,770	2,31,86,455

GRAM TARANG FOODS PRIVATE LIMITED
Notes Forming Part of Financial Statements

Note : 9 Long Term Loans and Advances

Amount in ₹

S No	Particulars	31-Mar-18	31-Mar-17
1	Security Deposit Deposit - Sales TAX Dept Security Deposit - Ramsatya Agencies Security Deposit (Electricals)	15,000 50,000 2,43,365	15,000 50,000 2,43,365
2	MAT Credit Entitlement	6,13,801	5,95,485
	Total	9,22,166	9,03,850

Note : 10 Inventories

Amount in ₹

S No	Particulars	31-Mar-18	31-Mar-17
1	Inventories Raw Material	4,76,543	3,50,780
2	Stock in Trade Finished Goods	38,70,419	33,26,345
	Total	43,46,962	36,77,125

Note : 11 Trade Recievables

Amount in ₹

S No	Particulars	31-Mar-18	31-Mar-17
1	Outstanding for more than six months a) Secured, Considered Good : b) Unsecured, Considered Good : c) Doubtful	11,93,057	1,702
2	Other receivables a) Secured, Considered Good : b) Unsecured, Considered Good : c) Doubtful	15,67,763	21,30,403
	Total	27,60,820	21,32,105

Note : 12 Cash & Cash Equivalent

Amount in ₹

S No	Particulars	31-Mar-18	31-Mar-17
A	Balances with Banks With Andhra Bank A/c No. 043811100000186 With Andhra Bank -107411100000964 (Vizag)	2,19,645 4,912	4,092 4,912
	Sub Total (A)	2,24,557	9,004
B	Cash on Hand Cash Balance	21,196	1,01,550
	Sub Total (B)	21,196	1,01,550
	Total [A + B]	2,45,753	1,10,554

Note : 13 Short Term Loans and Advances

Amount in ₹

S No	Particulars	31-Mar-18	31-Mar-17
1	GST Input	1,68,353	
2	Prepaid Insurance	1,08,743	1,17,184
3	Other Advances	-	2,04,950
4	TDS Receivable	-	9,14,286
5	Income Tax Refund Due for AY 2017-18	3,18,801	
	Total	5,95,897	12,36,420

GRAM TARANG FOODS PRIVATE LIMITED
Notes Forming Part of Financial Statements

Note : 14 Revenue from Operations		Amount in ₹	
S No	Particulars	31-Mar-18	31-Mar-17
1	Local Sales and Services	1,37,09,554	32,65,344
2	Inter State Sales	21,61,000	65,82,346
	Total	1,58,70,554	98,47,690

Note : 15 Other Income		Amount in ₹	
S No	Particulars	31-Mar-18	31-Mar-17
1	Ginger Oleoresin	-	-
2	Transport Charges	13,265	27,889
3	Rental Income	10,51,429	2,62,857
4	Interest on Tds	-	133
5	Other Income	45,053	3,703
6	Sundry Creditors written off	-	57,49,905
7	Packing Charges	19,170	-
8	Insurance	11,275	-
	Total	11,40,192	60,44,487

Note : 16 Cost of Material Consumed		Amount in ₹	
S No	Particulars	31-Mar-18	31-Mar-17
1	Opening Stock	3,50,780	7,92,928
	Add: Purchases	50,64,952	50,11,250
	Add: Direct Expenses	4,44,461	1,19,254
		58,60,193	59,23,432
	Less: Closing Stocks	4,76,543	3,50,780
	Total	53,83,650	55,72,652

Note : 17 Changes in Inventories		Amount in ₹	
S No	Particulars	31-Mar-18	31-Mar-17
1	Inventories at the end of the Year		
	Finished Goods	38,70,419	33,26,345
	Total	38,70,419	33,26,345
2	Less: Inventories at the beginning of the Year		
	Finished Goods	33,26,345	7,97,462
	Total	33,26,345	7,97,462
	Net Increase/(Decrease)	5,44,074	25,28,883

Note : 18 Employee Benefit Expenses		Amount in ₹	
S No	Particulars	31-Mar-18	31-Mar-17
1	Salaries	13,22,930	7,78,654
2	Incentive	35,000	550
	Total	13,57,930	7,79,204

GRAM TARANG FOODS PRIVATE LIMITED

Notes Forming Part of Financial Statements

Note : 19 Financial Cost		Amount in ₹	
S No	Particulars	31-Mar-18	31-Mar-17
1	Interest on Term loan	10,91,814	17,41,904
2	Interest on CC	-	6,19,474
3	Processing Charges	-	23,000
4	Inspection Charges (Plant)-Andhra Bank	11,725	-
	Total	11,03,539	23,84,378

Note : 20 Depreciation & Amortised Cost		Amount in ₹	
S No	Particulars	31-Mar-18	31-Mar-17
1	Depreciation	38,65,131	47,21,132
	Total	38,65,131	47,21,132

Note : 21 Other Administrative Expenses		Amount in ₹	
S No	Particulars	31-Mar-18	31-Mar-17
1	Advertisement	27,637	8,631
2	Audit Fees	47,200	46,000
3	Bank Charges	4,409	49,296
4	Consumables for plant	73,077	32,154
5	Consultancy Fees	1,89,239	23,970
6	Commission	12,32,547	4,00,000
7	Electricity Charges	5,59,610	4,37,641
8	Fees and membership	1,55,035	5,000
9	Fooding Exp.	38,985	19,596
10	Insurance	1,43,130	96,013
11	Penal Interest	46,875	8,987
12	Input Service Tax	11,800	-
13	Laboratory Test Charges	34,811	57,005
14	Loading & Unloading Charges	48,526	-
15	Lodging & Boarding and Travelling	1,15,964	803
16	Legal Expenses	-	12,800
17	Office Expenses	46,892	19,422
18	Transportation Charges	5,31,655	2,57,840
19	Postage & Courier Charges	12,364	1,487
20	Printing and Stationery	61,093	14,500
21	Repair & Maintance	5,72,750	1,23,879
22	Telephone Expenses	14,206	9,418
23	Professional Charges	11,800	65,300
24	Rent & Rates and Taxes	72,584	1,42,225
25	Website Expenses	-	6,640
26	Roc Charges	1,200	-
27	Bad debts written off	6,612	-
	Total	40,60,000	18,38,607

GRAM TARANG FOODS PRIVATE LIMITED

Other Notes Forming Integral Part of the Financial Statements as at 31st March, 2018

Note : 22 Earnings Per Share

Amount in ₹

S.No	Particulars	31-Mar-18	31-Mar-17
1	Net Profit for the year	19,06,787	(53,92,661)
2	Net Profit for the year attributable to the equity share holders (A)	19,06,787	(53,92,661)
3	Weighted Average Number of Equity Shares (B)	5,25,000	5,25,000
4	Par Value of Share	10	10
5	Earnings Per Share – Basic (A)/(B)	3.63	(10.27)
6	Adjustment in average number of share for Diluted earnings per share	-	-
7	Diluted Earnings Per Share	3.63	(10.27)

Note : 23 Deferred Tax

Amount in ₹

S.No	Particulars	31-Mar-18	31-Mar-17
1	Depreciation as per Companies Act	38,65,131	47,21,132
2	Depreciation as per Income Tax Act	33,38,386	39,23,076
3	Timing Difference	(5,26,745)	(7,98,056)
4	Current Year Deferred Tax (Asset)/ Liability	(1,36,954)	(2,46,599)
5	Opening Balance	(7,540)	2,39,059
	Closing Balance (Asset)/Liability	(1,44,494)	(7,540)

Note : 24 Payments To Auditors

Amount in ₹

S.No	Particulars	31-Mar-18	31-Mar-17
1	Statutory Audit Fees	30,000	30,000
2	Tax Audit Fees	10,000	10,000
3	GST/Service Tax	7,200	6,000
	Total	47,200	46,000

Note : 25 Related Party Disclosure

As per the Accounting Standard-18 on 'Related party disclosures' as notified by the Companies (accounting Standards) Rules-2006 the related parties of the company are as follows.

List of related parties

1. Key management personnel
 - a) Shashikant Tewary - Managing Director
 - b) DN Rao - Director
2. Group Companies
 - a) Gram Tarang Self Help Co-Operative Ltd.

Transactions with related parties

Amount in ₹

Particulars	Key Management Personnel		Group Companies	
	31-Mar-18	31-Mar-17	31-Mar-18	31-Mar-17
Shashikant Tewary Unsecured Loan	4,58,130	4,58,130	-	-
Unsecured Loan from Gram Tarang SelfHelp Co-Operative society	1,02,54,696	1,02,54,696	1,02,54,696	1,02,54,696

GRAM TARANG FOODS PRIVATE LIMITED

Note: 26 Disclosure required under Section 22 of the Micro, Small and Medium Enterprises Development Act, 2006

S No	Particulars	31-Mar-18	31-Mar-17
1	Principal amount remaining unpaid to any supplier as at the end of the accounting year		
2	Interest due thereon remaining unpaid to any supplier as at the end of the accounting year		
3	The amount of interest paid along with the amounts of the payment made to the supplier beyond the appointed day		
4	The amount of interest due and payable for the year	NIL	NIL
5	The amount of interest accrued and remaining unpaid at the end of the accounting year		
6	The amount of further interest due and payable even in the succeeding year, until such date when the interest dues as above are actually paid		

Note 27:

Previous year's figures have been regrouped / reclassified wherever necessary to correspond with the current year's classification / disclosure.

As per our report of even date attached to the
Balance Sheet and Profit and Loss Account

For SPC & Associates
Chartered Accountants
FRN: 005685S

CA Shruvan Kumar Reddy

Partner
MRN:240014

Hyderabad
Date: 17-08-2018

For GRAM TARANG FOODS PRIVATE LIMITED

Shashikant Tewary

Managing Director
DIN : 6453360

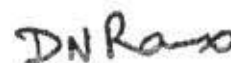

D.N.Rao
Director
DIN: 00939956

**FORM NO. MGT 9
EXTRACT OF ANNUAL RETURN**

As on financial year ended on 31.03.2018

[Pursuant to Section 92 (3) of the Companies Act, 2013 and rule 12(1) of the Company (Management & Administration) Rules, 2014.]

I. REGISTRATION & OTHER DETAILS:

1.	CIN	U15549AP2009PTC064398
2.	Registration Date	16/07/2009
3.	Name of the Company	GRAM TARANG FOODS PRIVATE LIMITED
4.	Category/Sub-category of the Company	A Non-Government Company limited by shares
5.	Address of the Registered office & contact details	B-107, KSR Pleasant Valley, Madhavadhara, Visakhapatnam, Andhra Pradesh-530018.
6.	Whether listed company	No
7.	Name, Address & contact details of the Registrar & Transfer Agent, if any.	ROC-Hyderabad.

II. PRINCIPAL BUSINESS ACTIVITIES OF THE COMPANY (All the business activities contributing 10 % or more of the total turnover of the company shall be stated)

S. No.	Name and Description of main products / services	NIC Code of the Product/service	% to total turnover of the company
1	Food Products	1040	100%

III. PARTICULARS OF HOLDING, SUBSIDIARY AND ASSOCIATE COMPANIES-

Sino	Name and Address of the Company	CIN/GLN	Holding/ Subsidiary/ Associate	% of shares held	Applicable Section
NIL					

B) Shareholding of Promoter-

SN	Shareholder's Name	Shareholding at the beginning of the year			Shareholding at the end of the year			% change in shareholding during the year
		No. of Shares	% of total Shares of the company	% of Shares Pledged / encumbered to total shares	No. of Shares	% of total Shares of the company	% of Shares Pledged / encumbered to total shares	
1	Mukti Kantha Mishra	118334	22.54%	-	118334	22.54%	-	-
2	Shashikanth Tewary	163333	31.11%	-	163333	31.11%	-	-
3	Supriya Patanaik	50000	9.52%	-	50000	9.52%	-	-
4	DN Rao	163333	31.11%	-	168333	31.11%	-	-

C) Change in Promoters' Shareholding (please specify, if there is no change)

SN	Particulars	Shareholding at the beginning of the year		Cumulative Shareholding during the year	
		No. of shares	% of total shares of the company	No. of shares	% of total shares of the company
	At the beginning of the year				
	Date wise Increase / Decrease in Promoters Shareholding during the year specifying the reasons for increase /decrease (e.g. allotment / transfer / bonus/ sweat equity etc.)				
	At the end of the year				

There is no change in shareholding during the year.

D) Shareholding Pattern of top ten Shareholders:

(Other than Directors, Promoters and Holders of GDRs and ADRs):

Sl. No	For Each of the Top 10 Shareholders	Shareholding at the beginning of the year		Cumulative Shareholding during the year	
		No. of shares	% of total shares of the company	No. of shares	% of total shares of the company
	At the beginning of the year	-	-	-	-
	Date wise Increase / Decrease in Shareholding during the year specifying the reasons for increase /decrease (e.g. allotment / transfer / bonus/ sweat equity etc):	-	-	-	-
	At the end of the year	-	-	-	-

E) Shareholding of Directors and Key Managerial Personnel:

Sl. No	Shareholding of each Directors and each Key Managerial Personnel	Shareholding at the beginning of the year		Cumulative Shareholding during the year	
		No. of shares	% of total shares of the company	No. of shares	% of total shares of the company
	At the beginning of the year	3,31,666	63.17%	3,31,666	63.17%
	Date wise Increase / Decrease in Shareholding during the year specifying the reasons for increase /decrease (e.g. allotment / transfer / bonus/ sweat equity etc.)	-	-	-	-
	At the end of the year	3,31,666	63.17%	3,31,666	63.17%

V) INDEBTEDNESS -Indebtedness of the Company including interest outstanding/accrued but not due for payment.

Particulars	Secured Loans excluding deposits	Unsecured Loans	Deposits	Total Indebtedness
Indebtedness at the beginning of the financial year				
i) Principal Amount	86,66,349	1,52,12,826	-	2,38,79,175
ii) Interest due but not paid	-	-	-	-
iii) Interest accrued but not due	-	-	-	-
Total (i+ii+iii)	86,66,349	1,52,12,826	-	2,38,79,175
Change in Indebtedness during the financial year				
* Addition	-	-	-	-
* Reduction	(43,78,925)			(43,78,925)
Net Change	(43,78,925)			(43,78,925)
Indebtedness at the end of the financial year				
i) Principal Amount	42,87,424	1,52,12,826		1,95,00,250
ii) Interest due but not paid	-	-	-	-
iii) Interest accrued but not due	-	-	-	-
Total (i+ii+iii)	42,87,424	1,52,12,826		1,95,00,250

VI. REMUNERATION OF DIRECTORS AND KEY MANAGERIAL PERSONNEL-

A. Remuneration to Managing Director, Whole-time Directors and/or Manager:

SN.	Particulars of Remuneration	Name of MD/WTD/ Manager		Total
1	Gross salary	Not Applicable		
	(a) Salary as per provisions contained in section 17(1) of the Income-tax Act, 1961			
	(b) Value of perquisites u/s 17(2) Income-tax Act, 1961			
	(c) Profits in lieu of salary under section 17(3) Income- tax Act, 1961			
2	Stock Option			
3	Sweat Equity			
4	Commission - as % of profit - others, specify...			
5	Others, please specify(TDS)			
	Total (A)			
	Ceiling as per the Act			

B. Remuneration to other directors

SN.	Particulars of Remuneration	Name of Directors	Total Amount
1	Independent Directors	NIL	
	Fee for attending board committee meetings		
	Commission		
	Others, please specify		
	Total (1)		
2	Other Non-Executive Directors		
	Fee for attending board committee meetings		
	Commission		
	Others, please specify		
	Total (2)		
	Total (B)=(1+2)		
	Total Managerial Remuneration		
	Overall Ceiling as per the Act		

C. REMUNERATION TO KEY MANAGERIAL PERSONNEL OTHER THAN MD/MANAGER/WTD

SN	Particulars of Remuneration	Key Managerial Personnel			
		CEO	CS	CFO	Total
1	Gross salary		NIL		
	(a) Salary as per provisions contained in section 17(1) of the Income-tax Act, 1961				
	(b) Value of perquisites u/s 17(2) Income-tax Act, 1961				
	(c) Profits in lieu of salary under section 17(3) Income-tax Act, 1961				
2	Stock Option				
3	Sweat Equity				
4	Commission				
	- as % of profit				
	Others, specify...				
5	Others, please specify				
	Total				

VII. PENALTIES / PUNISHMENT / COMPOUNDING OF OFFENCES:

Type	Section of the Companies Act	Brief Description	Details of Penalty / Punishment/ Compounding fees imposed	Authority [RD / NCLT/ COURT]	Appeal made, if any (give Details)
A. COMPANY					
Penalty			NIL		
Punishment					
Compounding					
B. DIRECTORS					
Penalty			NIL		
Punishment					
Compounding					
C. OTHER OFFICERS IN DEFAULT					
Penalty			NIL		
Punishment					
Compounding					

IV. SHARE HOLDING PATTERN
(Equity Share Capital Breakup as Percentage of Total Equity)

Category of Shareholders	No. of Shares held at the end of the year [As on 31-March-2016]			No. of Shares held at the end of the year [As on 31-March-2017]			% Change during the year
	Physical	Total	% of Total Shares	Physical	Total	% of Total Shares	
A. Promoters							
(1) Indian							
a) Individual/ HUF	4,50,000	4,50,000	85.71%	4,50,000	4,50,000	85.71%	0%
b) Central Govt							
c) State Govt(s)							
d) Bodies Corp.							
e) Banks / FI							
f) Any other							
Total shareholding of Promoter (A)	4,50,000	4,50,000	85.71%	4,50,000	4,50,000	85.71%	0%
B. Public Shareholding							
1. Institutions							
a) Mutual Funds							
b) Banks / FI							
c) Central Govt							
d) State Govt(s)							
e) Venture Capital Funds							
f) Insurance Companies							
g) FIIs							
h) Foreign Venture Capital Funds							

i) Others (specify)													
Sub-total (B)(1):-													
2. Non-Institutions													
a) Bodies Corp.													
i) Indian													
ii) Overseas													
b) Individuals													
i) Individual shareholders holding nominal share capital up to Rs. 1 lakh		75,000		75,000		75,000		75,000		75,000		14.29%	0.00%
ii) Individual shareholders holding nominal share capital in excess of Rs 1 lakh													
c) Others (specify)													
Overseas Corporate Bodies													
Sub-total (B)(2):-													
Total Public Shareholding (B) = (B)(1) + (B)(2)													
C. Shares held by Custodian for GDRs & ADRs													
Grand Total (A+B+C)		5,25,000		5,25,000		5,25,000		5,25,000		5,25,000		100.00%	0%



29th September, 2018

To,

M/s. SPC & Associates,
Chartered Accountants,
Plot No-252A, Lotus pond Road
Road No-12, Banjara Hills
Hyderabad- 500034.

Dear Sir,

Sub.: Appointment as Statutory Auditors for the F.Y. 2018-19– reg.
Ref.: 9th Annual General Meeting of the Company.

This has reference to the above cited subject and 9th Annual General Meeting of the Company was held on Saturday, 29th September 2018.

In this regard, we are pleased to inform you that you firm M/s. SPC & Associates Chartered Accountants be and here by appointed as statutory auditors of the company to hold office from the conclusion of this Meeting until the conclusion of the Annual General Meeting (AGM) of the company to be held in the year 2019 subject to ratification of the appointment at every AGM at a remuneration (including term of payment) to be fixed by the board of Direction of the company, plus Goods and service tax and such other taxes, as may be applicable & reimbursement of all out-of-pocket expenses in connection with the audit of the accounts of the company.

This is for your information and necessary action.

Thanking you

Yours truly,

For GRAM TARANG FOODS PRIVATE LIMITED

Shashikanth Tewary
Director
DIN – (06453360)



Date: 10th July, 2018

To
SPC & Associates,
Chartered Accountants,
Plot No #252A, 2nd Floor, MLA Colony,
Lotus Pond Road, Road #12, Banjara Hills,
Hyderabad.

Dear Sirs,

FINANCIAL STATEMENTS FOR THE PERIOD ENDED 31st MARCH, 2018

This representation letter is provided in connection with your audit of the financial statements of **Gram Tarang Foods Private Limited** for the year ended **31st March, 2018**, for the purpose of expressing an opinion as to whether the financial statements give a true and fair view of the financial position of **Gram Tarang Foods Private Limited** as of **31st March, 2018**, and of the results of its operations for the year then ended in accordance with the Companies Act, 2013 and Generally Accepted Accounting Practices in India.

We acknowledge our responsibility for the fair presentation of the financial statements in accordance with the Companies Act, 2013 and Generally Accepted Accounting Practices in India.

We confirm to the best of our knowledge and belief, the following representations:

- We acknowledge our responsibilities for the design, implementation, and operation of accounting and internal control systems that are designed to prevent and detect fraud and error.
- Following our assessment of the risk that the financial statements may be materially misstated as a result of fraud, we are not aware of any significant facts relating to any frauds or suspected frauds or irregularities known that have involved (i) Management; (ii) Employees who have significant roles in internal control; or (iii) Others where the fraud could have a material effect on the financial statements; and, of any allegations of fraud, or suspected fraud, affecting the financial statements that have been communicated to us by employees, former employees, analysts, regulators and others.
- We have made available to you all books of account and supporting documentation and all minutes of meetings of shareholders and the board of directors.
- We confirm the completeness of the information provided regarding the identification of related parties. Related party transactions are conducted on terms substantially equivalent to those that prevail in an arm's length transaction except for the loans taken.
- The related party loans have been taken for aiding the business activities and hence they were granted without any interest.
- We are aware of the observations you made, qualifications reported and notes attached to the accounts. We assure you that all necessary steps will be taken by the management to follow the best practices, implement the suggestions made and comply with those rules and regulations which could not be done during the year.



- We accept that the Company has delayed in filing forms with the Registrar of Companies regarding the shares allotted to the new investors. We are also aware of the fact that the Company's borrowings are more than the net worth of the Company.
- The Company is not covered under any of the labour laws as of now but it shall be responsible to deposit the statutory contributions once it is covered under the Acts.
- We are also aware of the fact that the Company shall be responsible to revise the VAT (statutory) returns.
- The Company has complied with all aspects of contractual agreements that could have a material effect on the financial statements in the event of non-compliance. There has been no non-compliance with requirements of regulatory authorities that could have a material effect on the financial statements in the event of non-compliance.
- The following have been properly recorded and when appropriate, adequately disclosed in the financial statements:
 - (a) The identity of, and balances and transactions with, related parties.
 - (b) All litigation, claims or possible claims and estimates thereof.
- We have no plans to abandon lines of product or other plans or intentions that will result in any excess or obsolete inventory, and no inventory is stated at an amount in excess of net realisable value.
- The Company has satisfactory title to all assets and there are no liens or encumbrances on the Company's assets.
- We have recorded or disclosed, as appropriate, all liabilities both actual and contingent, and have disclosed in the notes to the financial statements all guarantees that we have given to third parties, if any.
- Events subsequent to period end which require adjustment of or disclosure in the financial statements or notes thereto are as disclosed in the financial statements.
- We have assessed future action relating to continuing operations and confirm that there are no events or conditions that have been identified, indicating that the Company will not be a going concern.
- The management hereby confirms that none of the directors is disqualified as on March 31, 2018, from being appointed as a director in terms of sub-section (2) of Section 164 of the Companies Act, 2013.

Yours faithfully

Gram Tarang Foods Private Limited

Shashikant Tewary

Director

DIN : 6453360

Independent Auditor's Report

To the Members of
GRAM TARANG FOODS PRIVATE LIMITED

Report on the Financial Statements

We have audited the accompanying financial statements of **GRAM TARANG FOODS PRIVATE LIMITED** ("the Company"), which comprise the Balance Sheet as at 31st March, 2018, the Statement of Profit and Loss and the statement of cash flows for the year ended and a summary of significant accounting policies and other explanatory information.

Management's Responsibility for the Financial Statements

The Company's Board of Directors is responsible for the matters stated in Section 134(5) of the Companies Act, 2013 ("the Act") with respect to the preparation and presentation of these financial statements that give a true and fair view of the financial position, financial performance and of the Company in accordance with the accounting principles generally accepted in India, including the Accounting Standards specified under Section 133 of the Act, read with Rule 7 of the Companies (Accounts) Rules, 2014.

This responsibility also includes maintenance of adequate accounting records in accordance with the provisions of the Act for safeguarding the assets of the Company and for preventing and detecting frauds and other irregularities; selection and application of appropriate accounting policies; making judgments and estimates that are reasonable and prudent; and design, implementation and maintenance of adequate internal financial controls, that were operating effectively for ensuring the accuracy and completeness of the accounting records, relevant to the preparation and presentation of the financial statements that give a true and fair view and are free from material misstatement, whether due to fraud or error.

Auditor's Responsibility for the Financial Statements

Our responsibility is to express an opinion on these financial statements based on our audit. We have taken into account the provisions of the Act, the accounting and auditing standards and matters which are required to be included in the audit report under the provisions of the Act and the Rules made there under.



We conducted our audit in accordance with the Standards on Auditing specified under Section 143(10) of the Act. Those Standards require that we comply with ethical requirements and plan and perform the audit to obtain reasonable assurance about whether the financial statements are free from material misstatement.

An audit involves performing procedures to obtain audit evidence about the amounts and the disclosures in the financial statements. The procedures selected depend on the auditor's judgment, including the assessment of the risks of material misstatement of the financial statements, whether due to fraud or error. In making those risk assessments, the auditor considers internal financial controls relevant to the Company's preparation of the financial statements that give a true and fair view in order to design audit procedures that are appropriate in the circumstances.

An audit also includes evaluating the appropriateness of the accounting policies used and the reasonableness of the accounting estimates made by the Company's Directors, as well as evaluating the overall presentation of the financial statements.

We believe that the audit evidence we have obtained is sufficient and appropriate to provide a basis for our audit opinion on the financial statements

Opinion

In our opinion and to the best of our information and according to the explanations given to us, the financial statements give the information required by the Act in the manner so required and give a true and fair view in conformity with the accounting principles generally accepted in India:

- a) In the case of the Balance Sheet, of the state of affairs of the Company as at March 31, 2018;
- b) In the case of the Statement of Profit and Loss, of the profit for the year ended on that date.
- c) In the case of the statement of cash flows, the cash flows for the year ended on that date

Report on Other Legal and Regulatory Requirements

1. As required by the Companies (Auditor's Report) Order, 2016 ("the Order") issued by the Central Government of India in terms of sub-section (11) of section 143 of the Act, 2013 is not applicable
2. As required by Section 143(3) of the Act, we report that:
 - a) We have obtained all the information and explanations which to the best of our knowledge and belief were necessary for the purpose of our audit;





SPC&ASSOCIATES

Chartered Accountants

- b) In our opinion proper books of account as required by law have been kept by the Company so far as appears from our examination of those books
- c) The Balance Sheet and the Statement of Profit and Loss, dealt with by this Report are in agreement with the books of accounts and returns.
- d) In our opinion, the Balance Sheet, Statement of Profit and Loss, comply with the Accounting Standards referred to in of Section 133 of the Companies Act, 2013, read with Rule 7 of the Company (Accounts) Rules 2014.
- e) On the basis of written representations received from the directors as on March 31, 2018, and taken on record by the Board of Directors, none of the directors is disqualified as on March 31, 2018, from being appointed as a director in terms of sub-section (2) of Section 164 of the Companies Act, 2013.
- f) With respect to the other matters included in the Auditor's Report and to our best of our information and according to the explanations given to us:
 - i) The Company does not have any pending litigations which would impact its financial position.
 - ii) The Company has not entered into any long-term contracts including derivatives contracts requiring provision under applicable laws or accounting standards, for material foreseeable losses and
 - iii) No amount is required to be transferred to investor education and protection fund in accordance with the relevant provisions of the Companies Act, 2013. Hence delay in depositing the amounts to the said fund is not applicable.

For SPC&Associates
Chartered Accountants
FRN: 005685S

CA Shrvan Kumar Reddy
Partner
MRN: 240014

Place: Vishakhapatnam
Date: 17th August, 2018

Principal Place of Business/Bill To					Supply To						
RSB Transmissions (I) Ltd. (Forging Plant) Plot no. 1007, 1011 P.O. Uchapada Tel : 91674-2550590 Fax : 91674-2550590 Email : ranjan.jena@rsbglobal.com Website : www.rsbglobal.com GSTIN : 21AABCR3925R1Z5 PAN : AABCR3925R State Code & State : 21 ODISHA CIN : U34102PN1989PLC014807					RSB TRANSMISSIONS (I) LTD. (Cuttack) CUTTACK UNIT -1, NH-5,PLOT NO.1011,1007 MANIA,KOTSAHI,TANGI.CHOUDWAR 754022 Tel : 91674-2550590 Fax : 91674-2550590 Email : ranjan.jena@rsbglobal.com Website : www.rsbglobal.com GSTIN : 21AABCR3925R1Z5 PAN : AABCR3925R State Code & State : 21 ODISHA CIN : U34102PN1989PLC014807						
Supplier Details					PO Details						
Supplier Code : 40536453 Name : GramTarang Employability Trng Serv P Ltd Address : HIG5,BDA Duplex phase-I Pokhariput GTET,At.JITM,PO.R.Sitapur,Via.Uppalada , Paralakhemundi Tel : Email : sidharth.dash@gramtarang.org.in GSTIN : 21AABCC9406C1ZB PAN : AABCC9406C State Code & State : 21 ODISHA					Order Type/Order No : OH / 18000408 Order Date : 09/18/18 Revision No/ Date : 0 / 09/22/18 Quotation No/ Date : Our Reference No. : Original Order No. : Validity Date : 03/31/19						
No.	Item Code	Drawing No.	HSN	Quantity	Rate	GST Amount/Percentage			Request Date	Amount (Qty x Rate)	
	Description	Mod No:	SAC	UOM	Currency	IGST	CGST	SGST			
1	M06050020 SHEARING BLADE 65X65 WITH MATERIAL		84559000	20.000 EA	7420.00 INR		13356.00 @ 9.0 %	13356.00 @ 9.0 %	09/18/18	148400.00	
2	M06050021 SHEARING BLADE 75X75 WITH MATERIAL		84559000	10.000 EA	7420.00 INR		6678.00 @ 9.0 %	6678.00 @ 9.0 %	09/18/18	74200.00	
									Total :	222600.00	
									CGST Input@9%	20034.00	
									SGST Input@9%	20034.00	
									Other		
									Suspense Account		
									Suspense Setoff Account		
									Grand Total :	262668.00	
Grand Total (In Words) : Rupees Two Lakh Sixty Two Thousand Six Hundred Sixty Eight Only. Delivery Terms : AS PER LAST SUPPLY. Remarks : Payment Terms : 30 Days From Acceptance											

Checked By

Authorized By

Principal Place of Business/Bill To					Supply To					
RSB Transmissions (I) Ltd. (Forging Plant) Plot no. 1007, 1011 P.O. Uchapada Tel : 91674-2550590 Fax : 91674-2550590 Email : ranjan.jena@rsbglobal.com Website : www.rsbglobal.com GSTIN : 21AABCR3925R1Z5 PAN : AABCR3925R State Code & State : 21 ODISHA CIN : U34102PN1989PLC014807					RSB TRANSMISSIONS (I) LTD.(Cuttack) CUTTACK UNIT -1, NH-5,PLOT NO.1011,1007 MANIA,KOTSAHI,TANGI.CHOUDWAR 754022 Tel : 91674-2550590 Fax : 91674-2550590 Email : ranjan.jena@rsbglobal.com Website : www.rsbglobal.com GSTIN : 21AABCR3925R1Z5 PAN : AABCR3925R State Code & State : 21 ODISHA CIN : U34102PN1989PLC014807					
Supplier Details					PO Details					
Supplier Code : 40536453 Name : GramTarang Employability Trng Serv P Ltd Address : HIG5,BDA Duplex phase-I Pokhariput GTET,At.JITM,PO.R.Sitapur,Via.Uppalada , Paralakhemundi Tel : Email : sidharth.dash@gramtarang.org.in GSTIN : 21AABCC9406C1ZB PAN : AABCC9406C State Code & State : 21 ODISHA					Order Type/Order No : OH / 17000471 Order Date : 12/11/17 Revision No/ Date : 0 / 12/12/17 Quotation No/ Date : Our Reference No. : mail dt.20.11.2017 Original Order No. : Validity Date : 03/30/18					
No.	Item Code	Drawing No.	HSN	Quantity	Rate	GST Amount/Percentage			Request Date	Amount
	Description	Mod No:	SAC	UOM	Currency	IGST	CGST	SGST		(Qty x Rate)
1	M06050020 SHEARING BLADE 65X65		84559000	3.000 EA	7420.00 INR		2003.40 @ 9.0 %	2003.40 @ 9.0 %	12/11/17	22260.00
2	M06050021 SHEARING BLADE 75X75		84559000	3.000 EA	7420.00 INR		2003.40 @ 9.0 %	2003.40 @ 9.0 %	12/11/17	22260.00
									Total :	44520.00
									CGST Input@9%	4006.80
									SGST Input@9%	4006.80
									Grand Total :	52533.60
Grand Total (In Words) : Rupees Fifty Two Thousand Five Hundred Thirty Three and paise Sixty Only. Delivery Terms : EX-WORKS. Remarks : Payment Terms : 30 Days From Acceptance										

Checked By

Authorized By

 For all queries related to this order contact
 www.rsbglobal.com

CORPORATE OFFICE: Ubale Nagar, Nagar Road, Wagoli, Pune, 412207, Tel : 91 20 30642100 Fax : 91 20 30642101

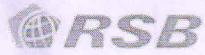

PURCHASE ORDER

RSB TRANSMISSIONS (I) LTD - Cuttack

Cuttack Unit -1, Nh-5,Plot No.1011,1007
 Mania,Kotsahi,Tangi,Choudwar 754022 (Odisha)
 Tel : 91674- 2550590
 Fax : 91674- 2550590
 Email : dilip.kayastha@rsbglobal.com
 Website : www.rsbglobal.com

VAT No. / TIN : 21821119946 w.e.f : Dec 3, 2009
 CST No. / TIN : 21821119946-C w.e.f : Dec 3, 2009
 ECC No. : AABCR3925RXM007
 RANGE : II, Kapaleswar, Choudwar, Cuttack-754025
 DIVISION : Sector-6,Abhinay Bidanas, C.D.A, Cuttack
 COMMISSIONERATE : BBSR-1, Central Revenu Bldg,RajaswaVihar
 PAN : AABCR3925R

SUPPLIER DETAILS
40536453 Gramtarang Employability Trng Serv P Ltd Hig5,Bda Duplex Phase-I Pokhariput Gtet,At.Jitm,Po.R.Sitapur,Via.Uppalada Paralakhemundi sidharth.dash@gramtarang.org.in PAN # AABCC9406C

PO DETAILS
Order Type/ Number : OH / 16000139 Order Date : May 10, 2016 Revision No/ Date : 0 / May 10, 2016 Quotation No/ Date : Our Reference Number : Validity Date : Jul 29, 2016

No.	Item Code Description	Drawing No: Mod No:	Quantity UOM	Rate (Currency)	Requested Date	Amount
1	M06050021 SHEARING BLADE 75X75	Mod # : " "	2.00 EA	7420.00 INR	May 10, 2016	14840.00
2	M06050020 SHEARING BLADE 65X65	Mod # : " "	2.00 EA	7420.00 INR	May 10, 2016	14840.00

Total: **29680.00**

VAT@5%
Freight 1484.00

Grand Total: **31164.00**

Grand Total (in Words) : Rupees Thirty One Thousand One Hundred Sixty Four And Paise Zero Only
 Delivery Terms : Ex-Works
 Remarks :
 Payment Terms : 30 Days From Acceptance

Checked By:

For all queries related to this order contact : ranjan.jana@rsbglobal.com
 CORPORATE OFFICE : Ubale Nagar, Nagar Road, Wagholi, Pune : 412207, Tel : 91 20 30642100 Fax : 91 20 30642101

Authorized By:



PURCHASE ORDER

Principal Place of Business/Bill To					Supply To						
RSB Transmissions (I) Ltd. (Forging Plant) Plot no. 1007, 1011 P.O. Uchapada Tel : 91674-2550590 Fax : 91674-2550590 Email : ranjan.jena@rsbglobal.com Website : www.rsbglobal.com GSTIN : 21AABCR3925R1Z5 PAN : AABCR3925R State Code & State : 21 ODISHA CIN : U34102PN1989PLC014807					RSB TRANSMISSIONS (I) LTD.(Cuttack) CUTTACK UNIT -1, NH-5,PLOT NO.1011,1007 MANIA,KOTSAHI,TANGI,CHOUDWAR 754022 Tel : 91674-2550590 Fax : 91674-2550590 Email : ranjan.jena@rsbglobal.com Website : www.rsbglobal.com GSTIN : 21AABCR3925R1Z5 PAN : AABCR3925R State Code & State : 21 ODISHA CIN : U34102PN1989PLC014807						
Supplier Details					PO Details						
Supplier Code : 40007025 Name : GRAMTARANG EMPLOYABILITY TRNG SERV P LTD Address : C/O ? CENTURION UNIVERSITY GRAM TARANG EMPLOYABILITY TRAINING SERVICES, AT- RAMACHANDRAPUR,JATANI , BHUBANESWAR Tel : Email : subratkumar.swain@gramtarang.org.in GSTIN : 21AABCC9406C1ZB PAN :AABCC9406C State Code & State : 21 ODISHA					Order Type/Order No : O2 / 18000210 Order Date : 09/14/18 Revision No/ Date : 0 / 09/14/18 Quotation No/ Date : Our Reference No. : Original Order No. : Validity Date : 12/14/18						
No.	Item Code	Drawing No.	HSN	Quantity	Rate	GST Amount/Percentage			Request Date	Amount	
	Description	Mod No:	SAC	UOM	Currency	IGST	CGST	SGST		(Qty x Rate)	
1	ZMRS0069 FINISHER TOP D1203L WELDING DIE REPAIR		998331	2.000 EA	6202.80 INR		1116.50 @ 9.0 %	1116.50 @ 9.0 %	09/14/18	12405.60	
2	ZMRS0069 BLOCKER TOP D1203L WELDING DIE REPAIR		998331	1.000 EA	4032.00 INR		362.88 @ 9.0 %	362.88 @ 9.0 %	09/14/18	4032.00	
3	ZMRS0069 FINISHER BOTTOM D1203L WELDING DIE REPAIR		998331	1.000 EA	4320.00 INR		388.80 @ 9.0 %	388.80 @ 9.0 %	09/14/18	4320.00	
									Total :	20757.60	
									CGST Input@9%	1868.18	
									SGST Input@9%	1868.18	
									Other		
									Suspense Account		
									Suspense Setoff Account		
									Grand Total :	24493.97	
Grand Total (In Words) : Rupees Twenty Four Thousand Four Hundred Ninety Three and paise Ninety Seven Only. Delivery Terms : Remarks : Payment Terms : 30 Days From Acceptance											

Checked By

Authorized By

For all queries related to this order contact
www.rsbglobal.com

CORPORATE OFFICE: Ubale Nagar, Nagar Road, Wagoli, Pune, 412207, Tel : 91 20 30642100 Fax : 91 20 30642101

TERMS & CONDITIONS**GENERAL**

1. Written acceptance of this PO or Commencement of supply/service against this PO shall constitute acceptance of this Purchase Order.
2. Delivery Challan/Invoice in duplicate should accompany all supplies made mentioning in there clearly supplier code, drawing no., part no., description of material PO no. specified in Purchase/subcontract & quantity supplied.
3. In the case of excisable goods transporter's copy should be send along with material otherwise bill/invoice will be held up. Failure to comply with this & consequent loss of mod vat credit on account of excise duty will be debited to your account where document are routed through bank send the transporter copy along with consent & enclose copy of invoice with document routed through bank. Attested/certified/Photostat copies of transporter's copy of invoice are not acceptable at all.
4. In case of subcontract item with our material failure to supply or return the material within 90 days under rule 4(5)(a) of central excise the excise duty payable in then will be debited to your account.
5. All drawings samples or technical data supplied to you by us shall be kept as secret & shall not be sold or disclosed & these shall be returned to as & when demanded. Failure to comply with this shall make you liable for breach of trust & other actions as may be deemed fit by us.
6. The items manufactured by you from the date furnished by us must not be sold or divulged by you to any other party than ourselves. If you manufacture excess quantity than our order you shall preserve the same for ultimate sale to us on our demand. Alternatively you destroy the goods so manufactured by you. By no account you will sell goods to any other party except with our written consent. The same condition applies to supplies rejected by us parts similar to parts manufactured for us; should not be manufactured by you.
7. No upward revision of price will be permitted during the period of contract unless agreed by us.
8. Terms & condition stated in our purchase/subcontract will be final until the supplier has our written consent to his terms & conditions if any stated in his order acceptance letter.
9. Any letter sent by prepaid registered post to the address given in this order shall be deemed to have been received by party within 3 days of dispatch thereof; irrespective of fact whether the said letter is or is not in fact received by party so addressed.
10. The company reserves the right to cancel & terminate the contract. If prevented by any intervention or control by government authorities or any other cause beyond the control of the company where by company is unable to make use the materials ordered by stoppage suspension of production or otherwise.
11. Local civil court shall have the jurisdiction to try any dispute concerning all our purchase/subcontract.
12. The material should be properly packed to avoid any kind of damage or formation of rust during transportation or storage.
13. Strict adherence to terms of delivery is absolutely essential. The company reserves the right to treat the order as cancelled in the event of your non-compliance of delivery schedule agreed & material will be brought from open market at your risk & cost. Time of delivery shall be essence of contract.
14. Demurrage, penalties etc. shall be levied on account of delay in delivery, dispatch or railway/lorry receipts, advance of invoice & challans or any other shipping documents or for any other reason for which the company is not responsible will be to the supplier's account & recoverable from him.
15. The material must be dispatched by the mode or transport & to the destination mentioned in this order. In case partial suppliers our prior approval must be obtained.
16. If transport arrangement is made by RSB for collection & dispatch of components it will be totally the supplier's risk RSB is not responsible for any shortages damages in such Arrangement supplier should send their representative with each consignment for collection & delivery to ensure safe transit of material.
17. Supplier shall give advance information to buyer in writing for all specification change design changes as well as major changes in processing location of manufacturing applying to goods covered by this Purchase order.
18. All vehicles used for transportation of material should comply to the central motor & vehicle rules act as applicable from time to time. The transporter is required to carry PUC vehicle fitness certificate of transportation vehicle during delivery.
19. Supplier should inform dispatch details immediately after dispatch.
20. Material supplied by seller shall satisfy current Govt. & environmental (ISO 14001-2004) & safety (OHSAS-18001-2007) constraints on restricted toxic & hazardous materials.
21. Supplier shall ensure coverage of transit insurance for material.
22. Supplier shall protect the third party trade secret or proprietary information for material or copy rights supplied by RSB. Failure to do so will result in PO being cancelled with immediate effect.

PAYMENT

1. Payment will be made as stipulated in this order, if the payment is agreed to be made against document through Bank. All bank charges involved shall be borne by the Supplier. Failure by the Supplier to advice his banker to recover all bank charges from supplier. Will result is non-retirement of documents at his own risk and cost.
2. All payments will be done as per applicable RSB policies.
3. No charges for cartage, packing etc., will admissible unless the same is specifically included in our Purchase/ Sub Contract.

SUPPLIER'S QUALITY ASSURANCE

1. All the materials, Component supplied must critically meet RSB Quality standards required as per samples, drawings, specifications or any other related instructions. The supplier shall allow, RSB's employee and authorized representatives for the purpose of inspecting manufacturing and inspection facilities, inspection of raw materials, WIP, FG, machines tools, fixtures jigs or any other items in connection with the manufacture of components for the company.

SAMPLE APPROVAL

1. No supplies should be made prior to the approval of sample unless specifically asked by us. It shall be the responsibility of the Supplier to submit samples well in time to be able to adhere strictly to the delivery schedule.

REJECTIONS

1. The decisions of the company on rejection shall be final and binding on the Supplier and this time clause shall be deemed to constitute an agreement to the contrary under the Sale of Goods Act. The company shall be entitled to reject the materials at any stage, cancel the contract and buy its requirements in the open market against the supplies. There is no rejection allowed unless specifically mentioned in the P.O. clearly.
2. It will be the liability of the Supplier to remove the rejected material within 15 days from our premises at his cost. In case rejection is not taken back within 15 days RSB is not liable to return back the rejection & no compensation will be given. In case of any rework done the components supplied by the suppliers, rework charges, handling charges, disposal charges & any other related charges as applicable will be recovered from Supplier's bill.
3. Rejection must be replaced within the delivery schedule and will be invoiced separately and not as replacement. All charges inclusive of freight and handling on replacements shall be borne by the Supplier.

WARRANTY

1. All the material supplied, should be free from any manufacturing, process defects & should be as per the drawings, Specifications. Any failure at RSB's customer end due to any deviation on quality, supplier shall be responsible for all damages, claims, recovery directly or indirectly claimed to RSB by any agency. Supplier shall reimburse all such expenses to RSB immediately without any delay on any ground. It will be the responsibility of the supplier to provide free replacement of component & assemblies which fail in the field because of material or manufacturing defects during the Warranty period or during the product life cycle, any offered by the company to its customers.

IN THE CASE OF SUB CONTRACT

1. Material Account to be submitted every month with regards to the Receipts & Supply in the prescribed format.
2. The supplier is responsible for safe custody of Company's material including the RAW Material/ Semi Finished/Finished/Tooling.
3. Periodic Physical Verification will be carried out by company's representative. During which supplier should assist in such verification.
4. The supplier has to obtain in writing the quantum to be consumed for each item supplied to him.
5. Supplier is fully responsible for quantity lifted by him till the entire quantity is supplied by him as per specification.
6. The supplier should also return the resultant scrap generated during machining. The remaining material/semi finished/finished held by supplier shall be property of company & company reserves the right to seek for return of raw material in which event the supplier shall return the same forth with.
7. No process rejection is allowed unless specified in PO specifically. In case process rejection, rejected component should be returned back to RSB on a separate delivery challan. All such components should be marked with red paint & to be supplied in a separate batch to avoid mix up. Process rejection exceeding allowed rejection % full cost of raw material shall be recovered. Line rejection at RSB is not considered in the allowed process rejection (if any). Line rejection will be recovered at full cost & rejected components will not be returned back or no scrap benefit will be passed on to supplier.
8. Supplier should ensure coverage of insurance of RSB property on their premises at their own cost.

Checked By

Authorized By

For all queries related to this order contact
www.rsbglobal.com

CORPORATE OFFICE: Ubale Nagar, Nagar Road, Wagoli, Pune, 412207, Tel : 91 20 30642100 Fax : 91 20 30642101



PURCHASE ORDER

Principal Place of Business/Bill To					Supply To					
RSB Transmissions (I) Ltd. (Forging Plant) Plot no. 1007, 1011 P.O. Uchapada Tel : 91674-2550590 Fax : 91674-2550590 Email : ranjan.jena@rsbglobal.com Website : www.rsbglobal.com GSTIN : 21AABCR3925R1Z5 PAN : AABCR3925R State Code & State : 21 ODISHA CIN : U34102PN1989PLC014807					RSB TRANSMISSIONS (I) LTD.(Cuttack) CUTTACK UNIT -1, NH-5,PLOT NO.1011,1007 MANIA,KOTSAHI,TANGI,CHOUDWAR 754022 Tel : 91674-2550590 Fax : 91674-2550590 Email : ranjan.jena@rsbglobal.com Website : www.rsbglobal.com GSTIN : 21AABCR3925R1Z5 PAN : AABCR3925R State Code & State : 21 ODISHA CIN : U34102PN1989PLC014807					
Supplier Details					PO Details					
Supplier Code : 40007025 Name : GRAMTARANG EMPLOYABILITY TRNG SERV P LTD Address : C/O ? CENTURION UNIVERSITY GRAM TARANG EMPLOYABILITY TRAINING SERVICES, AT- RAMACHANDRAPUR,JATANI , BHUBANESWAR Tel : Email : subratkumar.swain@gramtarang.org.in GSTIN : 21AABCC9406C1ZB PAN :AABCC9406C State Code & State : 21 ODISHA					Order Type/Order No : O2 / 18000292 Order Date : 11/27/18 Revision No/ Date : 0 / 11/27/18 Quotation No/ Date : Our Reference No. : Original Order No. : Validity Date : 01/27/19					
No.	Item Code Description	Drawing No. Mod No:	HSN SAC	Quantity UOM	Rate Currency	GST Amount/Percentage			Request Date	Amount (Qty x Rate)
1	ZMRS0069 MACHINING CHARGES OF WELDED DIE 1123L FINISHER BOTTOM		998331	1.000 EA	4644.00 INR		417.96 @ 9.0 %	417.96 @ 9.0 %	11/27/18	4644.00
2	ZMRS0069 MACHINING CHARGES OF WELDED DIE 1123L FINISHER TOP		998331	1.000 EA	4644.00 INR		417.96 @ 9.0 %	417.96 @ 9.0 %	11/27/18	4644.00
3	ZMRS0069 MACHINING CHARGES OF WELDED DIE 1123L BLOCKER TOP		998331	1.000 EA	4572.00 INR		411.48 @ 9.0 %	411.48 @ 9.0 %	11/27/18	4572.00
4	ZMRS0069 MACHINING CHARGES OF WELDED DIE 1123L BLOCKER BOTTOM		998331	1.000 EA	4572.00 INR		411.48 @ 9.0 %	411.48 @ 9.0 %	11/27/18	4572.00
								Total :	18432.00	
								Packing & Forwarding Charges		
								CGST Input@9%	1658.88	
								SGST Input@9%	1658.88	
								Suspense Account		
								Suspense Setoff Account		
								Grand Total :	21749.76	
Grand Total (In Words) : Rupees Twenty One Thousand Seven Hundred Fourty Nine and paise Seventy Six Only. Delivery Terms : EX-WORKS.. Remarks : Payment Terms : 30 Days From Acceptance										

Checked By

Authorized By

For all queries related to this order contact
www.rsbglobal.com

CORPORATE OFFICE: Ubale Nagar, Nagar Road, Wagoli, Pune, 412207, Tel : 91 20 30642100 Fax : 91 20 30642101

TERMS & CONDITIONS**GENERAL**

1. Written acceptance of this PO or Commencement of supply/service against this PO shall constitute acceptance of this Purchase Order.
2. Delivery Challan/Invoice in duplicate should accompany all supplies made mentioning in there clearly supplier code, drawing no., part no., description of material PO no. specified in Purchase/subcontract & quantity supplied.
3. In the case of excisable goods transporter's copy should be send along with material otherwise bill/invoice will be held up. Failure to comply with this & consequent loss of mod vat credit on account of excise duty will be debited to your account where document are routed through bank send the transporter copy along with consent & enclose copy of invoice with document routed through bank. Attested/certified/Photostat copies of transporter's copy of invoice are not acceptable at all.
4. In case of subcontract item with our material failure to supply or return the material within 90 days under rule 4(5)(a) of central excise the excise duty payable in then will be debited to your account.
5. All drawings samples or technical data supplied to you by us shall be kept as secret & shall not be sold or disclosed & these shall be returned to as & when demanded. Failure to comply with this shall make you liable for breach of trust & other actions as may be deemed fit by us.
6. The items manufactured by you from the date furnished by us must not be sold or divulged by you to any other party than ourselves. If you manufacture excess quantity than our order you shall preserve the same for ultimate sale to us on our demand. Alternatively you destroy the goods so manufactured by you. By no account you will sell goods to any other party except with our written consent. The same condition applies to supplies rejected by us parts similar to parts manufactured for us; should not be manufactured by you.
7. No upward revision of price will be permitted during the period of contract unless agreed by us.
8. Terms & condition stated in our purchase/subcontract will be final until the supplier has our written consent to his terms & conditions if any stated in his order acceptance letter.
9. Any letter sent by prepaid registered post to the address given in this order shall be deemed to have been received by party within 3 days of dispatch thereof; irrespective of fact whether the said letter is or is not in fact received by party so addressed.
10. The company reserves the right to cancel & terminate the contract. If prevented by any intervention or control by government authorities or any other cause beyond the control of the company where by company is unable to make use the materials ordered by stoppage suspension of production or otherwise.
11. Local civil court shall have the jurisdiction to try any dispute concerning all our purchase/subcontract.
12. The material should be properly packed to avoid any kind of damage or formation of rust during transportation or storage.
13. Strict adherence to terms of delivery is absolutely essential. The company reserves the right to treat the order as cancelled in the event of your non-compliance of delivery schedule agreed & material will be brought from open market at your risk & cost. Time of delivery shall be essence of contract.
14. Demurrage, penalties etc. shall be levied on account of delay in delivery, dispatch or railway/lorry receipts, advance of invoice & challans or any other shipping documents or for any other reason for which the company is not responsible will be to the supplier's account & recoverable from him.
15. The material must be dispatched by the mode or transport & to the destination mentioned in this order. In case partial suppliers our prior approval must be obtained.
16. If transport arrangement is made by RSB for collection & dispatch of components it will be totally the supplier's risk RSB is not responsible for any shortages damages in such Arrangement supplier should send their representative with each consignment for collection & delivery to ensure safe transit of material.
17. Supplier shall give advance information to buyer in writing for all specification change design changes as well as major changes in processing location of manufacturing applying to goods covered by this Purchase order.
18. All vehicles used for transportation of material should comply to the central motor & vehicle rules act as applicable from time to time. The transporter is required to carry PUC vehicle fitness certificate of transportation vehicle during delivery.
19. Supplier should inform dispatch details immediately after dispatch.
20. Material supplied by seller shall satisfy current Govt. & environmental (ISO 14001-2004) & safety (OHSAS-18001-2007) constraints on restricted toxic & hazardous materials.
21. Supplier shall ensure coverage of transit insurance for material.
22. Supplier shall protect the third party trade secret or proprietary information for material or copy rights supplied by RSB. Failure to do so will result in PO being cancelled with immediate effect.

PAYMENT

1. Payment will be made as stipulated in this order, if the payment is agreed to be made against document through Bank. All bank charges involved shall be borne by the Supplier. Failure by the Supplier to advice his banker to recover all bank charges from supplier. Will result is non-retirement of documents at his own risk and cost.
2. All payments will be done as per applicable RSB policies.
3. No charges for cartage, packing etc., will admissible unless the same is specifically included in our Purchase/ Sub Contract.

SUPPLIER'S QUALITY ASSURANCE

1. All the materials, Component supplied must critically meet RSB Quality standards required as per samples, drawings, specifications or any other related instructions. The supplier shall allow, RSB's employee and authorized representatives for the purpose of inspecting manufacturing and inspection facilities, inspection of raw materials, WIP, FG, machines tools, fixtures jigs or any other items in connection with the manufacture of components for the company.

SAMPLE APPROVAL

1. No supplies should be made prior to the approval of sample unless specifically asked by us. It shall be the responsibility of the Supplier to submit samples well in time to be able to adhere strictly to the delivery schedule.

REJECTIONS

1. The decisions of the company on rejection shall be final and binding on the Supplier and this time clause shall be deemed to constitute an agreement to the contrary under the Sale of Goods Act. The company shall be entitled to reject the materials at any stage, cancel the contract and buy its requirements in the open market against the supplies. There is no rejection allowed unless specifically mentioned in the P.O. clearly.
2. It will be the liability of the Supplier to remove the rejected material within 15 days from our premises at his cost. In case rejection is not taken back within 15 days RSB is not liable to return back the rejection & no compensation will be given. In case of any rework done the components supplied by the suppliers, rework charges, handling charges, disposal charges & any other related charges as applicable will be recovered from Supplier's bill.
3. Rejection must be replaced within the delivery schedule and will be invoiced separately and not as replacement. All charges inclusive of freight and handling on replacements shall be borne by the Supplier.

WARRANTY

1. All the material supplied, should be free from any manufacturing, process defects & should be as per the drawings, Specifications. Any failure at RSB's customer end due to any deviation on quality, supplier shall be responsible for all damages, claims, recovery directly or indirectly claimed to RSB by any agency. Supplier shall reimburse all such expenses to RSB immediately without any delay on any ground. It will be the responsibility of the supplier to provide free replacement of component & assemblies which fail in the field because of material or manufacturing defects during the Warranty period or during the product life cycle, any offered by the company to its customers.

IN THE CASE OF SUB CONTRACT

1. Material Account to be submitted every month with regards to the Receipts & Supply in the prescribed format.
2. The supplier is responsible for safe custody of Company's material including the RAW Material/ Semi Finished/Finished/Tooling.
3. Periodic Physical Verification will be carried out by company's representative. During which supplier should assist in such verification.
4. The supplier has to obtain in writing the quantum to be consumed for each item supplied to him.
5. Supplier is fully responsible for quantity lifted by him till the entire quantity is supplied by him as per specification.
6. The supplier should also return the resultant scrap generated during machining. The remaining material/semi finished/finished held by supplier shall be property of company & company reserves the right to seek for return of raw material in which event the supplier shall return the same forth with.
7. No process rejection is allowed unless specified in PO specifically. In case process rejection, rejected component should be returned back to RSB on a separate delivery challan. All such components should be marked with red paint & to be supplied in a separate batch to avoid mix up. Process rejection exceeding allowed rejection % full cost of raw material shall be recovered. Line rejection at RSB is not considered in the allowed process rejection (if any). Line rejection will be recovered at full cost & rejected components will not be returned back or no scrap benefit will be passed on to supplier.
8. Supplier should ensure coverage of insurance of RSB property on their premises at their own cost.

Checked By

Authorized By

For all queries related to this order contact
www.rsbglobal.com

CORPORATE OFFICE: Ubale Nagar, Nagar Road, Wagoli, Pune, 412207, Tel : 91 20 30642100 Fax : 91 20 30642101



PURCHASE ORDER

Principal Place of Business/Bill To					Supply To						
RSB Transmissions (I) Ltd. (Forging Plant) Plot no. 1007, 1011 P.O. Uchapada Tel : 91674-2550590 Fax : 91674-2550590 Email : ranjan.jena@rsbglobal.com Website : www.rsbglobal.com GSTIN : 21AABCR3925R1Z5 PAN : AABCR3925R State Code & State : 21 ODISHA CIN : U34102PN1989PLC014807					RSB TRANSMISSIONS (I) LTD.(Cuttack) CUTTACK UNIT -1, NH-5,PLOT NO.1011,1007 MANIA,KOTSAHI,TANGI,CHOUDWAR 754022 Tel : 91674-2550590 Fax : 91674-2550590 Email : ranjan.jena@rsbglobal.com Website : www.rsbglobal.com GSTIN : 21AABCR3925R1Z5 PAN : AABCR3925R State Code & State : 21 ODISHA CIN : U34102PN1989PLC014807						
Supplier Details					PO Details						
Supplier Code : 40007025 Name : GRAMTARANG EMPLOYABILITY TRNG SERV P LTD Address : C/O ? CENTURION UNIVERSITY GRAM TARANG EMPLOYABILITY TRAINING SERVICES, AT- RAMACHANDRAPUR,JATANI , BHUBANESWAR Tel : Email : subratkumar.swain@gramtarang.org.in GSTIN : 21AABCC9406C1ZB PAN :AABCC9406C State Code & State : 21 ODISHA					Order Type/Order No : O2 / 18000262 Order Date : 11/01/18 Revision No/ Date : 0 / 11/01/18 Quotation No/ Date : Our Reference No. : Original Order No. : Validity Date : 02/01/19						
No.	Item Code	Drawing No.	HSN	Quantity	Rate	GST Amount/Percentage			Request Date	Amount	
	Description	Mod No:	SAC	UOM	Currency	IGST	CGST	SGST		(Qty x Rate)	
1	ZMRS0069 MACHINING CHARGES OF 1ST LINE ROUND CLAMP		998331	6.000 EA	5256.00 INR		2838.24 @ 9.0 %	2838.24 @ 9.0 %	11/01/18	31536.00	
2	ZMRS0069 MACHINING CHARGES OF 2ND LINE RECTANGULAR CLAMP		998331	6.000 EA	5940.00 INR		3207.60 @ 9.0 %	3207.60 @ 9.0 %	11/01/18	35640.00	
									Total :	67176.00	
									Packing & Forwarding Charges		
									CGST Input@9%	6045.84	
									SGST Input@9%	6045.84	
									Suspense Account		
									Suspense Setoff Account		
									Grand Total :	79267.68	
Grand Total (In Words) : Rupees Seventy Nine Thousand Two Hundred Sixty Seven and paise Sixty Eight Only. Delivery Terms : EX-WORKS.. Remarks : Payment Terms : 30 Days From Acceptance											

Checked By

Authorized By

For all queries related to this order contact
www.rsbglobal.com

CORPORATE OFFICE: Ubale Nagar, Nagar Road, Wagoli, Pune, 412207, Tel : 91 20 30642100 Fax : 91 20 30642101

TERMS & CONDITIONS**GENERAL**

1. Written acceptance of this PO or Commencement of supply/service against this PO shall constitute acceptance of this Purchase Order.
2. Delivery Challan/Invoice in duplicate should accompany all supplies made mentioning in there clearly supplier code, drawing no., part no., description of material PO no. specified in Purchase/subcontract & quantity supplied.
3. In the case of excisable goods transporter's copy should be send along with material otherwise bill/invoice will be held up. Failure to comply with this & consequent loss of mod vat credit on account of excise duty will be debited to your account where document are routed through bank send the transporter copy along with consent & enclose copy of invoice with document routed through bank. Attested/certified/Photostat copies of transporter's copy of invoice are not acceptable at all.
4. In case of subcontract item with our material failure to supply or return the material within 90 days under rule 4(5)(a) of central excise the excise duty payable in then will be debited to your account.
5. All drawings samples or technical data supplied to you by us shall be kept as secret & shall not be sold or disclosed & these shall be returned to as & when demanded. Failure to comply with this shall make you liable for breach of trust & other actions as may be deemed fit by us.
6. The items manufactured by you from the date furnished by us must not be sold or divulged by you to any other party than ourselves. If you manufacture excess quantity than our order you shall preserve the same for ultimate sale to us on our demand. Alternatively you destroy the goods so manufactured by you. By no account you will sell goods to any other party except with our written consent. The same condition applies to supplies rejected by us parts similar to parts manufactured for us; should not be manufactured by you.
7. No upward revision of price will be permitted during the period of contract unless agreed by us.
8. Terms & condition stated in our purchase/subcontract will be final until the supplier has our written consent to his terms & conditions if any stated in his order acceptance letter.
9. Any letter sent by prepaid registered post to the address given in this order shall be deemed to have been received by party within 3 days of dispatch thereof; irrespective of fact whether the said letter is or is not in fact received by party so addressed.
10. The company reserves the right to cancel & terminate the contract. If prevented by any intervention or control by government authorities or any other cause beyond the control of the company where by company is unable to make use the materials ordered by stoppage suspension of production or otherwise.
11. Local civil court shall have the jurisdiction to try any dispute concerning all our purchase/subcontract.
12. The material should be properly packed to avoid any kind of damage or formation of rust during transportation or storage.
13. Strict adherence to terms of delivery is absolutely essential. The company reserves the right to treat the order as cancelled in the event of your non-compliance of delivery schedule agreed & material will be brought from open market at your risk & cost. Time of delivery shall be essence of contract.
14. Demurrage, penalties etc. shall be levied on account of delay in delivery, dispatch or railway/lorry receipts, advance of invoice & challans or any other shipping documents or for any other reason for which the company is not responsible will be to the supplier's account & recoverable from him.
15. The material must be dispatched by the mode or transport & to the destination mentioned in this order. In case partial suppliers our prior approval must be obtained.
16. If transport arrangement is made by RSB for collection & dispatch of components it will be totally the supplier's risk RSB is not responsible for any shortages damages in such Arrangement supplier should send their representative with each consignment for collection & delivery to ensure safe transit of material.
17. Supplier shall give advance information to buyer in writing for all specification change design changes as well as major changes in processing location of manufacturing applying to goods covered by this Purchase order.
18. All vehicles used for transportation of material should comply to the central motor & vehicle rules act as applicable from time to time. The transporter is required to carry PUC vehicle fitness certificate of transportation vehicle during delivery.
19. Supplier should inform dispatch details immediately after dispatch.
20. Material supplied by seller shall satisfy current Govt. & environmental (ISO 14001-2004) & safety (OHSAS-18001-2007) constraints on restricted toxic & hazardous materials.
21. Supplier shall ensure coverage of transit insurance for material.
22. Supplier shall protect the third party trade secret or proprietary information for material or copy rights supplied by RSB. Failure to do so will result in PO being cancelled with immediate effect.

PAYMENT

1. Payment will be made as stipulated in this order, if the payment is agreed to be made against document through Bank. All bank charges involved shall be borne by the Supplier. Failure by the Supplier to advice his banker to recover all bank charges from supplier. Will result is non-retirement of documents at his own risk and cost.
2. All payments will be done as per applicable RSB policies.
3. No charges for cartage, packing etc., will admissible unless the same is specifically included in our Purchase/ Sub Contract.

SUPPLIER'S QUALITY ASSURANCE

1. All the materials, Component supplied must critically meet RSB Quality standards required as per samples, drawings, specifications or any other related instructions. The supplier shall allow, RSB's employee and authorized representatives for the purpose of inspecting manufacturing and inspection facilities, inspection of raw materials, WIP, FG, machines tools, fixtures jigs or any other items in connection with the manufacture of components for the company.

SAMPLE APPROVAL

1. No supplies should be made prior to the approval of sample unless specifically asked by us. It shall be the responsibility of the Supplier to submit samples well in time to be able to adhere strictly to the delivery schedule.

REJECTIONS

1. The decisions of the company on rejection shall be final and binding on the Supplier and this time clause shall be deemed to constitute an agreement to the contrary under the Sale of Goods Act. The company shall be entitled to reject the materials at any stage, cancel the contract and buy its requirements in the open market against the supplies. There is no rejection allowed unless specifically mentioned in the P.O. clearly.
2. It will be the liability of the Supplier to remove the rejected material within 15 days from our premises at his cost. In case rejection is not taken back within 15 days RSB is not liable to return back the rejection & no compensation will be given. In case of any rework done the components supplied by the suppliers, rework charges, handling charges, disposal charges & any other related charges as applicable will be recovered from Supplier's bill.
3. Rejection must be replaced within the delivery schedule and will be invoiced separately and not as replacement. All charges inclusive of freight and handling on replacements shall be borne by the Supplier.

WARRANTY

1. All the material supplied, should be free from any manufacturing, process defects & should be as per the drawings, Specifications. Any failure at RSB's customer end due to any deviation on quality, supplier shall be responsible for all damages, claims, recovery directly or indirectly claimed to RSB by any agency. Supplier shall reimburse all such expenses to RSB immediately without any delay on any ground. It will be the responsibility of the supplier to provide free replacement of component & assemblies which fail in the field because of material or manufacturing defects during the Warranty period or during the product life cycle, any offered by the company to its customers.

IN THE CASE OF SUB CONTRACT

1. Material Account to be submitted every month with regards to the Receipts & Supply in the prescribed format.
2. The supplier is responsible for safe custody of Company's material including the RAW Material/ Semi Finished/Finished/Tooling.
3. Periodic Physical Verification will be carried out by company's representative. During which supplier should assist in such verification.
4. The supplier has to obtain in writing the quantum to be consumed for each item supplied to him.
5. Supplier is fully responsible for quantity lifted by him till the entire quantity is supplied by him as per specification.
6. The supplier should also return the resultant scrap generated during machining. The remaining material/semi finished/finished held by supplier shall be property of company & company reserves the right to seek for return of raw material in which event the supplier shall return the same forth with.
7. No process rejection is allowed unless specified in PO specifically. In case process rejection, rejected component should be returned back to RSB on a separate delivery challan. All such components should be marked with red paint & to be supplied in a separate batch to avoid mix up. Process rejection exceeding allowed rejection % full cost of raw material shall be recovered. Line rejection at RSB is not considered in the allowed process rejection (if any). Line rejection will be recovered at full cost & rejected components will not be returned back or no scrap benefit will be passed on to supplier.
8. Supplier should ensure coverage of insurance of RSB property on their premises at their own cost.

Checked By

Authorized By

For all queries related to this order contact
www.rsbglobal.com

CORPORATE OFFICE: Ubale Nagar, Nagar Road, Wagoli, Pune, 412207, Tel : 91 20 30642100 Fax : 91 20 30642101



PURCHASE ORDER

Principal Place of Business/Bill To					Supply To					
RSB Transmissions (I) Ltd. (Forging Plant) Plot no. 1007, 1011 P.O. Uchapada Tel : 91674-2550590 Fax : 91674-2550590 Email : ranjan.jena@rsbglobal.com Website : www.rsbglobal.com GSTIN : 21AABCR3925R1Z5 PAN : AABCR3925R State Code & State : 21 ODISHA CIN : U34102PN1989PLC014807					RSB TRANSMISSIONS (I) LTD.(Cuttack) CUTTACK UNIT -1, NH-5,PLOT NO.1011,1007 MANIA,KOTSAHI,TANGI,CHOUDWAR 754022 Tel : 91674-2550590 Fax : 91674-2550590 Email : ranjan.jena@rsbglobal.com Website : www.rsbglobal.com GSTIN : 21AABCR3925R1Z5 PAN : AABCR3925R State Code & State : 21 ODISHA CIN : U34102PN1989PLC014807					
Supplier Details					PO Details					
Supplier Code : 40007025 Name : GRAMTARANG EMPLOYABILITY TRNG SERV P LTD Address : C/O ? CENTURION UNIVERSITY GRAM TARANG EMPLOYABILITY TRAINING SERVICES, AT- RAMACHANDRAPUR,JATANI , BHUBANESWAR Tel : Email : subratkumar.swain@gramtarang.org.in GSTIN : 21AABCC9406C1ZB PAN : AABCC9406C State Code & State : 21 ODISHA					Order Type/Order No : OS / 18000043 Order Date : 12/25/18 Revision No/ Date : 0 / 12/25/18 Quotation No/ Date : Our Reference No. : AS PER CAM SHEET Original Order No. : Validity Date : 03/30/19					
No.	Item Code	Drawing No.	HSN	Quantity	Rate	GST Amount/Percentage			Request Date	Amount (Qty x Rate)
	Description	Mod No:	SAC	UOM	Currency	IGST	CGST	SGST		
1	PBBD1225*OP10 BLOCKER BOTTOM D1225		40092200	1.000 EA	10944.00 INR		984.96 @ 9.0 %	984.96 @ 9.0 %	12/25/18	10944.00
2	PFTD1225*OP10 FINISHER TOP D1225		40092200	1.000 EA	11952.00 INR		1075.68 @ 9.0 %	1075.68 @ 9.0 %	12/25/18	11952.00
							Total :			22896.00
							CGST Input@9%			2060.64
							SGST Input@9%			2060.64
							Other			
							Suspense Account			
							Suspense Setoff Account			
							Grand Total :			27017.28
Grand Total (In Words) : Rupees Twenty Seven Thousand Seventeen and paise Twenty Eight Only. Delivery Terms : EX-WORKS. Remarks : Payment Terms : 30 Days From Acceptance										

Checked By

Authorized By

For all queries related to this order contact
www.rsbglobal.com

CORPORATE OFFICE: Ubale Nagar, Nagar Road, Wagoli, Pune, 412207, Tel : 91 20 30642100 Fax : 91 20 30642101

TERMS & CONDITIONS**GENERAL**

1. Written acceptance of this PO or Commencement of supply/service against this PO shall constitute acceptance of this Purchase Order.
2. Delivery Challan/Invoice in duplicate should accompany all supplies made mentioning in there clearly supplier code, drawing no., part no., description of material PO no. specified in Purchase/subcontract & quantity supplied.
3. In the case of excisable goods transporter's copy should be send along with material otherwise bill/invoice will be held up. Failure to comply with this & consequent loss of mod vat credit on account of excise duty will be debited to your account where document are routed through bank send the transporter copy along with consent & enclose copy of invoice with document routed through bank. Attested/certified/Photostat copies of transporter's copy of invoice are not acceptable at all.
4. In case of subcontract item with our material failure to supply or return the material within 90 days under rule 4(5)(a) of central excise the excise duty payable in then will be debited to your account.
5. All drawings samples or technical data supplied to you by us shall be kept as secret & shall not be sold or disclosed & these shall be returned to as & when demanded. Failure to comply with this shall make you liable for breach of trust & other actions as may be deemed fit by us.
6. The items manufactured by you from the date furnished by us must not be sold or divulged by you to any other party than ourselves. If you manufacture excess quantity than our order you shall preserve the same for ultimate sale to us on our demand. Alternatively you destroy the goods so manufactured by you. By no account you will sell goods to any other party except with our written consent. The same condition applies to supplies rejected by us parts similar to parts manufactured for us; should not be manufactured by you.
7. No upward revision of price will be permitted during the period of contract unless agreed by us.
8. Terms & condition stated in our purchase/subcontract will be final until the supplier has our written consent to his terms & conditions if any stated in his order acceptance letter.
9. Any letter sent by prepaid registered post to the address given in this order shall be deemed to have been received by party within 3 days of dispatch thereof; irrespective of fact whether the said letter is or is not in fact received by party so addressed.
10. The company reserves the right to cancel & terminate the contract. If prevented by any intervention or control by government authorities or any other cause beyond the control of the company where by company is unable to make use the materials ordered by stoppage suspension of production or otherwise.
11. Local civil court shall have the jurisdiction to try any dispute concerning all our purchase/subcontract.
12. The material should be properly packed to avoid any kind of damage or formation of rust during transportation or storage.
13. Strict adherence to terms of delivery is absolutely essential. The company reserves the right to treat the order as cancelled in the event of your non-compliance of delivery schedule agreed & material will be brought from open market at your risk & cost. Time of delivery shall be essence of contract.
14. Demurrage, penalties etc. shall be levied on account of delay in delivery, dispatch or railway/lorry receipts, advance of invoice & challans or any other shipping documents or for any other reason for which the company is not responsible will be to the supplier's account & recoverable from him.
15. The material must be dispatched by the mode or transport & to the destination mentioned in this order. In case partial suppliers our prior approval must be obtained.
16. If transport arrangement is made by RSB for collection & dispatch of components it will be totally the supplier's risk RSB is not responsible for any shortages damages in such Arrangement supplier should send their representative with each consignment for collection & delivery to ensure safe transit of material.
17. Supplier shall give advance information to buyer in writing for all specification change design changes as well as major changes in processing location of manufacturing applying to goods covered by this Purchase order.
18. All vehicles used for transportation of material should comply to the central motor & vehicle rules act as applicable from time to time. The transporter is required to carry PUC vehicle fitness certificate of transportation vehicle during delivery.
19. Supplier should inform dispatch details immediately after dispatch.
20. Material supplied by seller shall satisfy current Govt. & environmental (ISO 14001-2004) & safety (OHSAS-18001-2007) constraints on restricted toxic & hazardous materials.
21. Supplier shall ensure coverage of transit insurance for material.
22. Supplier shall protect the third party trade secret or proprietary information for material or copy rights supplied by RSB. Failure to do so will result in PO being cancelled with immediate effect.

PAYMENT

1. Payment will be made as stipulated in this order, if the payment is agreed to be made against document through Bank. All bank charges involved shall be borne by the Supplier. Failure by the Supplier to advice his banker to recover all bank charges from supplier. Will result is non-retirement of documents at his own risk and cost.
2. All payments will be done as per applicable RSB policies.
3. No charges for cartage, packing etc., will admissible unless the same is specifically included in our Purchase/ Sub Contract.

SUPPLIER'S QUALITY ASSURANCE

1. All the materials, Component supplied must critically meet RSB Quality standards required as per samples, drawings, specifications or any other related instructions. The supplier shall allow, RSB's employee and authorized representatives for the purpose of inspecting manufacturing and inspection facilities, inspection of raw materials, WIP, FG, machines tools, fixtures jigs or any other items in connection with the manufacture of components for the company.

SAMPLE APPROVAL

1. No supplies should be made prior to the approval of sample unless specifically asked by us. It shall be the responsibility of the Supplier to submit samples well in time to be able to adhere strictly to the delivery schedule.

REJECTIONS

1. The decisions of the company on rejection shall be final and binding on the Supplier and this time clause shall be deemed to constitute an agreement to the contrary under the Sale of Goods Act. The company shall be entitled to reject the materials at any stage, cancel the contract and buy its requirements in the open market against the supplies. There is no rejection allowed unless specifically mentioned in the P.O. clearly.
2. It will be the liability of the Supplier to remove the rejected material within 15 days from our premises at his cost. In case rejection is not taken back within 15 days RSB is not liable to return back the rejection & no compensation will be given. In case of any rework done the components supplied by the suppliers, rework charges, handling charges, disposal charges & any other related charges as applicable will be recovered from Supplier's bill.
3. Rejection must be replaced within the delivery schedule and will be invoiced separately and not as replacement. All charges inclusive of freight and handling on replacements shall be borne by the Supplier.

WARRANTY

1. All the material supplied, should be free from any manufacturing, process defects & should be as per the drawings, Specifications. Any failure at RSB's customer end due to any deviation on quality, supplier shall be responsible for all damages, claims, recovery directly or indirectly claimed to RSB by any agency. Supplier shall reimburse all such expenses to RSB immediately without any delay on any ground. It will be the responsibility of the supplier to provide free replacement of component & assemblies which fail in the field because of material or manufacturing defects during the Warranty period or during the product life cycle, any offered by the company to its customers.

IN THE CASE OF SUB CONTRACT

1. Material Account to be submitted every month with regards to the Receipts & Supply in the prescribed format.
2. The supplier is responsible for safe custody of Company's material including the RAW Material/ Semi Finished/Finished/Tooling.
3. Periodic Physical Verification will be carried out by company's representative. During which supplier should assist in such verification.
4. The supplier has to obtain in writing the quantum to be consumed for each item supplied to him.
5. Supplier is fully responsible for quantity lifted by him till the entire quantity is supplied by him as per specification.
6. The supplier should also return the resultant scrap generated during machining. The remaining material/semi finished/finished held by supplier shall be property of company & company reserves the right to seek for return of raw material in which event the supplier shall return the same forth with.
7. No process rejection is allowed unless specified in PO specifically. In case process rejection, rejected component should be returned back to RSB on a separate delivery challan. All such components should be marked with red paint & to be supplied in a separate batch to avoid mix up. Process rejection exceeding allowed rejection % full cost of raw material shall be recovered. Line rejection at RSB is not considered in the allowed process rejection (if any). Line rejection will be recovered at full cost & rejected components will not be returned back or no scrap benefit will be passed on to supplier.
8. Supplier should ensure coverage of insurance of RSB property on their premises at their own cost.

Checked By

Authorized By

For all queries related to this order contact
www.rsbglobal.com

CORPORATE OFFICE: Ubale Nagar, Nagar Road, Wagoli, Pune, 412207, Tel : 91 20 30642100 Fax : 91 20 30642101



PURCHASE ORDER

Principal Place of Business/Bill To					Supply To					
RSB Transmissions (I) Ltd. (Forging Plant) Plot no. 1007, 1011 P.O. Uchapada Tel : 91674-2550590 Fax : 91674-2550590 Email : ranjan.jena@rsbglobal.com Website : www.rsbglobal.com GSTIN : 21AABCR3925R1Z5 PAN : AABCR3925R State Code & State : 21 ODISHA CIN : U34102PN1989PLC014807					RSB TRANSMISSIONS (I) LTD.(Cuttack) CUTTACK UNIT -1, NH-5,PLOT NO.1011,1007 MANIA,KOTSAHI,TANGI,CHOUDWAR 754022 Tel : 91674-2550590 Fax : 91674-2550590 Email : ranjan.jena@rsbglobal.com Website : www.rsbglobal.com GSTIN : 21AABCR3925R1Z5 PAN : AABCR3925R State Code & State : 21 ODISHA CIN : U34102PN1989PLC014807					
Supplier Details					PO Details					
Supplier Code : 40007025 Name : GRAMTARANG EMPLOYABILITY TRNG SERV P LTD Address : C/O ? CENTURION UNIVERSITY GRAM TARANG EMPLOYABILITY TRAINING SERVICES, AT- RAMACHANDRAPUR,JATANI , BHUBANESWAR Tel : Email : subratkumar.swain@gramtarang.org.in GSTIN : 21AABCC9406C1ZB PAN :AABCC9406C State Code & State : 21 ODISHA					Order Type/Order No : O2 / 18000304 Order Date : 12/04/18 Revision No/ Date : 0 / 12/04/18 Quotation No/ Date : Our Reference No. : Original Order No. : Validity Date : 03/04/19					
No.	Item Code	Drawing No.	HSN	Quantity	Rate	GST Amount/Percentage			Request Date	Amount
	Description	Mod No:	SAC	UOM	Currency	IGST	CGST	SGST		(Qty x Rate)
1	ZMRS0069 MACHINING CHARGES OF WELDED DIE 1203L FIN. BOTTOM		998331	1.000 EA	4428.00 INR		398.52 @ 9.0 %	398.52 @ 9.0 %	12/04/18	4428.00
2	ZMRS0069 MACHINING CHARGES OF WELDED DIE 1203L FIN. TOP		998331	1.000 EA	6372.00 INR		573.48 @ 9.0 %	573.48 @ 9.0 %	12/04/18	6372.00
									Total :	10800.00
									Packing & Forwarding Charges	
									CGST Input@9%	972.00
									SGST Input@9%	972.00
									Suspense Account	
									Suspense Setoff Account	
									Grand Total :	12744.00
Grand Total (In Words) : Rupees Twelve Thousand Seven Hundred Forty Four Only. Delivery Terms : Remarks : Payment Terms : 30 Days From Acceptance										

Checked By

Authorized By

For all queries related to this order contact
www.rsbglobal.com

CORPORATE OFFICE: Ubale Nagar, Nagar Road, Wagoli, Pune, 412207, Tel : 91 20 30642100 Fax : 91 20 30642101

TERMS & CONDITIONS**GENERAL**

1. Written acceptance of this PO or Commencement of supply/service against this PO shall constitute acceptance of this Purchase Order.
2. Delivery Challan/Invoice in duplicate should accompany all supplies made mentioning in there clearly supplier code, drawing no., part no., description of material PO no. specified in Purchase/subcontract & quantity supplied.
3. In the case of excisable goods transporter's copy should be send along with material otherwise bill/invoice will be held up. Failure to comply with this & consequent loss of mod vat credit on account of excise duty will be debited to your account where document are routed through bank send the transporter copy along with consent & enclose copy of invoice with document routed through bank. Attested/certified/Photostat copies of transporter's copy of invoice are not acceptable at all.
4. In case of subcontract item with our material failure to supply or return the material within 90 days under rule 4(5)(a) of central excise the excise duty payable in then will be debited to your account.
5. All drawings samples or technical data supplied to you by us shall be kept as secret & shall not be sold or disclosed & these shall be returned to as & when demanded. Failure to comply with this shall make you liable for breach of trust & other actions as may be deemed fit by us.
6. The items manufactured by you from the date furnished by us must not be sold or divulged by you to any other party than ourselves. If you manufacture excess quantity than our order you shall preserve the same for ultimate sale to us on our demand. Alternatively you destroy the goods so manufactured by you. By no account you will sell goods to any other party except with our written consent. The same condition applies to supplies rejected by us parts similar to parts manufactured for us; should not be manufactured by you.
7. No upward revision of price will be permitted during the period of contract unless agreed by us.
8. Terms & condition stated in our purchase/subcontract will be final until the supplier has our written consent to his terms & conditions if any stated in his order acceptance letter.
9. Any letter sent by prepaid registered post to the address given in this order shall be deemed to have been received by party within 3 days of dispatch thereof; irrespective of fact whether the said letter is or is not in fact received by party so addressed.
10. The company reserves the right to cancel & terminate the contract. If prevented by any intervention or control by government authorities or any other cause beyond the control of the company where by company is unable to make use the materials ordered by stoppage suspension of production or otherwise.
11. Local civil court shall have the jurisdiction to try any dispute concerning all our purchase/subcontract.
12. The material should be properly packed to avoid any kind of damage or formation of rust during transportation or storage.
13. Strict adherence to terms of delivery is absolutely essential. The company reserves the right to treat the order as cancelled in the event of your non-compliance of delivery schedule agreed & material will be brought from open market at your risk & cost. Time of delivery shall be essence of contract.
14. Demurrage, penalties etc. shall be levied on account of delay in delivery, dispatch or railway/lorry receipts, advance of invoice & challans or any other shipping documents or for any other reason for which the company is not responsible will be to the supplier's account & recoverable from him.
15. The material must be dispatched by the mode or transport & to the destination mentioned in this order. In case partial suppliers our prior approval must be obtained.
16. If transport arrangement is made by RSB for collection & dispatch of components it will be totally the supplier's risk RSB is not responsible for any shortages damages in such Arrangement supplier should send their representative with each consignment for collection & delivery to ensure safe transit of material.
17. Supplier shall give advance information to buyer in writing for all specification change design changes as well as major changes in processing location of manufacturing applying to goods covered by this Purchase order.
18. All vehicles used for transportation of material should comply to the central motor & vehicle rules act as applicable from time to time. The transporter is required to carry PUC vehicle fitness certificate of transportation vehicle during delivery.
19. Supplier should inform dispatch details immediately after dispatch.
20. Material supplied by seller shall satisfy current Govt. & environmental (ISO 14001-2004) & safety (OHSAS-18001-2007) constraints on restricted toxic & hazardous materials.
21. Supplier shall ensure coverage of transit insurance for material.
22. Supplier shall protect the third party trade secret or proprietary information for material or copy rights supplied by RSB. Failure to do so will result in PO being cancelled with immediate effect.

PAYMENT

1. Payment will be made as stipulated in this order, if the payment is agreed to be made against document through Bank. All bank charges involved shall be borne by the Supplier. Failure by the Supplier to advice his banker to recover all bank charges from supplier. Will result is non-retirement of documents at his own risk and cost.
2. All payments will be done as per applicable RSB policies.
3. No charges for cartage, packing etc., will admissible unless the same is specifically included in our Purchase/ Sub Contract.

SUPPLIER'S QUALITY ASSURANCE

1. All the materials, Component supplied must critically meet RSB Quality standards required as per samples, drawings, specifications or any other related instructions. The supplier shall allow, RSB's employee and authorized representatives for the purpose of inspecting manufacturing and inspection facilities, inspection of raw materials, WIP, FG, machines tools, fixtures jigs or any other items in connection with the manufacture of components for the company.

SAMPLE APPROVAL

1. No supplies should be made prior to the approval of sample unless specifically asked by us. It shall be the responsibility of the Supplier to submit samples well in time to be able to adhere strictly to the delivery schedule.

REJECTIONS

1. The decisions of the company on rejection shall be final and binding on the Supplier and this time clause shall be deemed to constitute an agreement to the contrary under the Sale of Goods Act. The company shall be entitled to reject the materials at any stage, cancel the contract and buy its requirements in the open market against the supplies. There is no rejection allowed unless specifically mentioned in the P.O. clearly.
2. It will be the liability of the Supplier to remove the rejected material within 15 days from our premises at his cost. In case rejection is not taken back within 15 days RSB is not liable to return back the rejection & no compensation will be given. In case of any rework done the components supplied by the suppliers, rework charges, handling charges, disposal charges & any other related charges as applicable will be recovered from Supplier's bill.
3. Rejection must be replaced within the delivery schedule and will be invoiced separately and not as replacement. All charges inclusive of freight and handling on replacements shall be borne by the Supplier.

WARRANTY

1. All the material supplied, should be free from any manufacturing, process defects & should be as per the drawings, Specifications. Any failure at RSB's customer end due to any deviation on quality, supplier shall be responsible for all damages, claims, recovery directly or indirectly claimed to RSB by any agency. Supplier shall reimburse all such expenses to RSB immediately without any delay on any ground. It will be the responsibility of the supplier to provide free replacement of component & assemblies which fail in the field because of material or manufacturing defects during the Warranty period or during the product life cycle, any offered by the company to its customers.

IN THE CASE OF SUB CONTRACT

1. Material Account to be submitted every month with regards to the Receipts & Supply in the prescribed format.
2. The supplier is responsible for safe custody of Company's material including the RAW Material/ Semi Finished/Finished/Tooling.
3. Periodic Physical Verification will be carried out by company's representative. During which supplier should assist in such verification.
4. The supplier has to obtain in writing the quantum to be consumed for each item supplied to him.
5. Supplier is fully responsible for quantity lifted by him till the entire quantity is supplied by him as per specification.
6. The supplier should also return the resultant scrap generated during machining. The remaining material/semi finished/finished held by supplier shall be property of company & company reserves the right to seek for return of raw material in which event the supplier shall return the same forth with.
7. No process rejection is allowed unless specified in PO specifically. In case process rejection, rejected component should be returned back to RSB on a separate delivery challan. All such components should be marked with red paint & to be supplied in a separate batch to avoid mix up. Process rejection exceeding allowed rejection % full cost of raw material shall be recovered. Line rejection at RSB is not considered in the allowed process rejection (if any). Line rejection will be recovered at full cost & rejected components will not be returned back or no scrap benefit will be passed on to supplier.
8. Supplier should ensure coverage of insurance of RSB property on their premises at their own cost.

Checked By

Authorized By

For all queries related to this order contact
www.rsbglobal.com

CORPORATE OFFICE: Ubale Nagar, Nagar Road, Wagoli, Pune, 412207, Tel : 91 20 30642100 Fax : 91 20 30642101



PURCHASE ORDER

Principal Place of Business/Bill To					Supply To						
RSB Transmissions (I) Ltd. (Forging Plant) Plot no. 1007, 1011 P.O. Uchapada Tel : 91674-2550590 Fax : 91674-2550590 Email : ranjan.jena@rsbglobal.com Website : www.rsbglobal.com GSTIN : 21AABCR3925R1Z5 PAN : AABCR3925R State Code & State : 21 ODISHA CIN : U34102PN1989PLC014807					RSB TRANSMISSIONS (I) LTD.(Cuttack) CUTTACK UNIT -1, NH-5,PLOT NO.1011,1007 MANIA,KOTSAHI,TANGI,CHOUDWAR 754022 Tel : 91674-2550590 Fax : 91674-2550590 Email : ranjan.jena@rsbglobal.com Website : www.rsbglobal.com GSTIN : 21AABCR3925R1Z5 PAN : AABCR3925R State Code & State : 21 ODISHA CIN : U34102PN1989PLC014807						
Supplier Details					PO Details						
Supplier Code : 40007025 Name : GRAMTARANG EMPLOYABILITY TRNG SERV P LTD Address : C/O ? CENTURION UNIVERSITY GRAM TARANG EMPLOYABILITY TRAINING SERVICES, AT- RAMACHANDRAPUR,JATANI , BHUBANESWAR Tel : Email : subratkumar.swain@gramtarang.org.in GSTIN : 21AABCC9406C1ZB PAN : AABCC9406C State Code & State : 21 ODISHA					Order Type/Order No : O2 / 18000354 Order Date : 01/10/19 Revision No/ Date : 0 / 01/10/19 Quotation No/ Date : Our Reference No. : Original Order No. : Validity Date : 03/10/19						
No.	Item Code	Drawing No.	HSN	Quantity	Rate	GST Amount/Percentage			Request Date	Amount (Qty x Rate)	
	Description	Mod No:	SAC	UOM	Currency	IGST	CGST	SGST			
1	ZMRS0069 MACHINING CHARGES OF WELDED DIE 1201 BLOCKER TOP		998331	1.000 EA	3024.00 INR		272.16 @ 9.0 %	272.16 @ 9.0 %	01/10/19	3024.00	
2	ZMRS0069 MACHINING CHARGES OF WELDED DIE 1201 FINISHER TOP		998331	1.000 EA	4248.00 INR		382.32 @ 9.0 %	382.32 @ 9.0 %	01/10/19	4248.00	
3	ZMRS0069 MACHINING CHARGES OF WELDED DIE 1201 FINISHER BOTTOM		998331	1.000 EA	3096.00 INR		278.64 @ 9.0 %	278.64 @ 9.0 %	01/10/19	3096.00	
4	ZMRS0069 MACHINING CHARGES OF WELDED DIE 1201 BLOCKER BOTTOM		998331	1.000 EA	4428.00 INR		398.52 @ 9.0 %	398.52 @ 9.0 %	01/10/19	4428.00	
									Total :	14796.00	
									Packing & Forwarding Charges		
									CGST Input@9%	1331.64	
									SGST Input@9%	1331.64	
									Suspense Account		
									Suspense Setoff Account		
									Grand Total :	17459.28	
Grand Total (In Words) : Rupees Seventeen Thousand Four Hundred Fifty Nine and paise Twenty Eight Only. Delivery Terms : Remarks : Payment Terms : 30 Days From Acceptance											

Checked By

Authorized By

For all queries related to this order contact
www.rsbglobal.com

CORPORATE OFFICE: Ubale Nagar, Nagar Road, Wagoli, Pune, 412207, Tel : 91 20 30642100 Fax : 91 20 30642101

TERMS & CONDITIONS**GENERAL**

1. Written acceptance of this PO or Commencement of supply/service against this PO shall constitute acceptance of this Purchase Order.
2. Delivery Challan/Invoice in duplicate should accompany all supplies made mentioning in there clearly supplier code, drawing no., part no., description of material PO no. specified in Purchase/subcontract & quantity supplied.
3. In the case of excisable goods transporter's copy should be send along with material otherwise bill/invoice will be held up. Failure to comply with this & consequent loss of mod vat credit on account of excise duty will be debited to your account where document are routed through bank send the transporter copy along with consent & enclose copy of invoice with document routed through bank. Attested/certified/Photostat copies of transporter's copy of invoice are not acceptable at all.
4. In case of subcontract item with our material failure to supply or return the material within 90 days under rule 4(5)(a) of central excise the excise duty payable in then will be debited to your account.
5. All drawings samples or technical data supplied to you by us shall be kept as secret & shall not be sold or disclosed & these shall be returned to as & when demanded. Failure to comply with this shall make you liable for breach of trust & other actions as may be deemed fit by us.
6. The items manufactured by you from the date furnished by us must not be sold or divulged by you to any other party than ourselves. If you manufacture excess quantity than our order you shall preserve the same for ultimate sale to us on our demand. Alternatively you destroy the goods so manufactured by you. By no account you will sell goods to any other party except with our written consent. The same condition applies to supplies rejected by us parts similar to parts manufactured for us; should not be manufactured by you.
7. No upward revision of price will be permitted during the period of contract unless agreed by us.
8. Terms & condition stated in our purchase/subcontract will be final until the supplier has our written consent to his terms & conditions if any stated in his order acceptance letter.
9. Any letter sent by prepaid registered post to the address given in this order shall be deemed to have been received by party within 3 days of dispatch thereof; irrespective of fact whether the said letter is or is not in fact received by party so addressed.
10. The company reserves the right to cancel & terminate the contract. If prevented by any intervention or control by government authorities or any other cause beyond the control of the company where by company is unable to make use the materials ordered by stoppage suspension of production or otherwise.
11. Local civil court shall have the jurisdiction to try any dispute concerning all our purchase/subcontract.
12. The material should be properly packed to avoid any kind of damage or formation of rust during transportation or storage.
13. Strict adherence to terms of delivery is absolutely essential. The company reserves the right to treat the order as cancelled in the event of your non-compliance of delivery schedule agreed & material will be brought from open market at your risk & cost. Time of delivery shall be essence of contract.
14. Demurrage, penalties etc. shall be levied on account of delay in delivery, dispatch or railway/lorry receipts, advance of invoice & challans or any other shipping documents or for any other reason for which the company is not responsible will be to the supplier's account & recoverable from him.
15. The material must be dispatched by the mode or transport & to the destination mentioned in this order. In case partial suppliers our prior approval must be obtained.
16. If transport arrangement is made by RSB for collection & dispatch of components it will be totally the supplier's risk RSB is not responsible for any shortages damages in such Arrangement supplier should send their representative with each consignment for collection & delivery to ensure safe transit of material.
17. Supplier shall give advance information to buyer in writing for all specification change design changes as well as major changes in processing location of manufacturing applying to goods covered by this Purchase order.
18. All vehicles used for transportation of material should comply to the central motor & vehicle rules act as applicable from time to time. The transporter is required to carry PUC vehicle fitness certificate of transportation vehicle during delivery.
19. Supplier should inform dispatch details immediately after dispatch.
20. Material supplied by seller shall satisfy current Govt. & environmental (ISO 14001-2004) & safety (OHSAS-18001-2007) constraints on restricted toxic & hazardous materials.
21. Supplier shall ensure coverage of transit insurance for material.
22. Supplier shall protect the third party trade secret or proprietary information for material or copy rights supplied by RSB. Failure to do so will result in PO being cancelled with immediate effect.

PAYMENT

1. Payment will be made as stipulated in this order, if the payment is agreed to be made against document through Bank. All bank charges involved shall be borne by the Supplier. Failure by the Supplier to advice his banker to recover all bank charges from supplier. Will result is non-retirement of documents at his own risk and cost.
2. All payments will be done as per applicable RSB policies.
3. No charges for cartage, packing etc., will admissible unless the same is specifically included in our Purchase/ Sub Contract.

SUPPLIER'S QUALITY ASSURANCE

1. All the materials, Component supplied must critically meet RSB Quality standards required as per samples, drawings, specifications or any other related instructions. The supplier shall allow, RSB's employee and authorized representatives for the purpose of inspecting manufacturing and inspection facilities, inspection of raw materials, WIP, FG, machines tools, fixtures jigs or any other items in connection with the manufacture of components for the company.

SAMPLE APPROVAL

1. No supplies should be made prior to the approval of sample unless specifically asked by us. It shall be the responsibility of the Supplier to submit samples well in time to be able to adhere strictly to the delivery schedule.

REJECTIONS

1. The decisions of the company on rejection shall be final and binding on the Supplier and this time clause shall be deemed to constitute an agreement to the contrary under the Sale of Goods Act. The company shall be entitled to reject the materials at any stage, cancel the contract and buy its requirements in the open market against the supplies. There is no rejection allowed unless specifically mentioned in the P.O. clearly.
2. It will be the liability of the Supplier to remove the rejected material within 15 days from our premises at his cost. In case rejection is not taken back within 15 days RSB is not liable to return back the rejection & no compensation will be given. In case of any rework done the components supplied by the suppliers, rework charges, handling charges, disposal charges & any other related charges as applicable will be recovered from Supplier's bill.
3. Rejection must be replaced within the delivery schedule and will be invoiced separately and not as replacement. All charges inclusive of freight and handling on replacements shall be borne by the Supplier.

WARRANTY

1. All the material supplied, should be free from any manufacturing, process defects & should be as per the drawings, Specifications. Any failure at RSB's customer end due to any deviation on quality, supplier shall be responsible for all damages, claims, recovery directly or indirectly claimed to RSB by any agency. Supplier shall reimburse all such expenses to RSB immediately without any delay on any ground. It will be the responsibility of the supplier to provide free replacement of component & assemblies which fail in the field because of material or manufacturing defects during the Warranty period or during the product life cycle, any offered by the company to its customers.

IN THE CASE OF SUB CONTRACT

1. Material Account to be submitted every month with regards to the Receipts & Supply in the prescribed format.
2. The supplier is responsible for safe custody of Company's material including the RAW Material/ Semi Finished/Finished/Tooling.
3. Periodic Physical Verification will be carried out by company's representative. During which supplier should assist in such verification.
4. The supplier has to obtain in writing the quantum to be consumed for each item supplied to him.
5. Supplier is fully responsible for quantity lifted by him till the entire quantity is supplied by him as per specification.
6. The supplier should also return the resultant scrap generated during machining. The remaining material/semi finished/finished held by supplier shall be property of company & company reserves the right to seek for return of raw material in which event the supplier shall return the same forth with.
7. No process rejection is allowed unless specified in PO specifically. In case process rejection, rejected component should be returned back to RSB on a separate delivery challan. All such components should be marked with red paint & to be supplied in a separate batch to avoid mix up. Process rejection exceeding allowed rejection % full cost of raw material shall be recovered. Line rejection at RSB is not considered in the allowed process rejection (if any). Line rejection will be recovered at full cost & rejected components will not be returned back or no scrap benefit will be passed on to supplier.
8. Supplier should ensure coverage of insurance of RSB property on their premises at their own cost.

Checked By

Authorized By

For all queries related to this order contact
www.rsbglobal.com

CORPORATE OFFICE: Ubale Nagar, Nagar Road, Wagoli, Pune, 412207, Tel : 91 20 30642100 Fax : 91 20 30642101



PURCHASE ORDER

Principal Place of Business/Bill To					Supply To						
RSB Transmissions (I) Ltd. (Forging Plant) Plot no. 1007, 1011 P.O. Uchapada Tel : 91674-2550590 Fax : 91674-2550590 Email : ranjan.jena@rsbglobal.com Website : www.rsbglobal.com GSTIN : 21AABCR3925R1Z5 PAN : AABCR3925R State Code & State : 21 ODISHA CIN : U34102PN1989PLC014807					RSB TRANSMISSIONS (I) LTD.(Cuttack) CUTTACK UNIT -1, NH-5,PLOT NO.1011,1007 MANIA,KOTSAHI,TANGI,CHOUDWAR 754022 Tel : 91674-2550590 Fax : 91674-2550590 Email : ranjan.jena@rsbglobal.com Website : www.rsbglobal.com GSTIN : 21AABCR3925R1Z5 PAN : AABCR3925R State Code & State : 21 ODISHA CIN : U34102PN1989PLC014807						
Supplier Details					PO Details						
Supplier Code : 40007025 Name : GRAMTARANG EMPLOYABILITY TRNG SERV P LTD Address : C/O ? CENTURION UNIVERSITY GRAM TARANG EMPLOYABILITY TRAINING SERVICES, AT- RAMACHANDRAPUR,JATANI , BHUBANESWAR Tel : Email : subratkumar.swain@gramtarang.org.in GSTIN : 21AABCC9406C1ZB PAN : AABCC9406C State Code & State : 21 ODISHA					Order Type/Order No : O2 / 18000396 Order Date : 13/02/2019 Revision No/ Date : 0 / 13/02/2019 Quotation No/ Date : Our Reference No. : Original Order No. : Validity Date : 31/03/2019						
No.	Item Code	Drawing No.	HSN	Quantity	Rate	GST Amount/Percentage			Request Date	Amount (Qty x Rate)	
	Description	Mod No:	SAC	UOM	Currency	IGST	CGST	SGST			
1	ZMRS0069 MACHINING CHARGES OF WELDED DIE 1225 FIN TOP		998331	1.000 EA	6912.00 INR		622.08 @ 9.0 %	622.08 @ 9.0 %	02/13/19	6912.00	
2	ZMRS0069 MACHINING CHARGES OF WELDED DIE 1225 FIN BTM		998331	1.000 EA	4068.00 INR		366.12 @ 9.0 %	366.12 @ 9.0 %	02/13/19	4068.00	
3	ZMRS0069 MACHINING CHARGES OF WELDED DIE 1225 BLK TOP		998331	1.000 EA	3790.80 INR		341.17 @ 9.0 %	341.17 @ 9.0 %	02/13/19	3790.80	
4	ZMRS0069 MACHINING CHARGES OF WELDED DIE 1225 BLK BTM		998331	1.000 EA	6660.00 INR		599.40 @ 9.0 %	599.40 @ 9.0 %	02/13/19	6660.00	
								Total :	21430.80		
								CGST Input@9%	1928.77		
								SGST Input@9%	1928.77		
								Other			
								Suspense Account			
								Suspense Setoff Account			
								Grand Total :	25288.34		
Grand Total (In Words) : RUPEES TWENTY FIVE THOUSAND TWO HUNDRED EIGHTY EIGHT AND PAISE THIRTY FOUR ONLY Delivery Terms : Remarks : Payment Terms : 30 Days From Acceptance											

Checked By

Authorized By

For all queries related to this order contact
www.rsbglobal.com

CORPORATE OFFICE: Ubale Nagar, Nagar Road, Wagoli, Pune, 412207, Tel : 91 20 30642100 Fax : 91 20 30642101

TERMS & CONDITIONS**GENERAL**

1. Written acceptance of this PO or Commencement of supply/service against this PO shall constitute acceptance of this Purchase Order.
2. Delivery Challan/Invoice in duplicate should accompany all supplies made mentioning in there clearly supplier code, drawing no., part no., description of material PO no. specified in Purchase/subcontract & quantity supplied.
3. In the case of excisable goods transporter's copy should be send along with material otherwise bill/invoice will be held up. Failure to comply with this & consequent loss of mod vat credit on account of excise duty will be debited to your account where document are routed through bank send the transporter copy along with consent & enclose copy of invoice with document routed through bank. Attested/certified/Photostat copies of transporter's copy of invoice are not acceptable at all.
4. In case of subcontract item with our material failure to supply or return the material within 90 days under rule 4(5)(a) of central excise the excise duty payable in then will be debited to your account.
5. All drawings samples or technical data supplied to you by us shall be kept as secret & shall not be sold or disclosed & these shall be returned to as & when demanded. Failure to comply with this shall make you liable for breach of trust & other actions as may be deemed fit by us.
6. The items manufactured by you from the date furnished by us must not be sold or divulged by you to any other party than ourselves. If you manufacture excess quantity than our order you shall preserve the same for ultimate sale to us on our demand. Alternatively you destroy the goods so manufactured by you. By no account you will sell goods to any other party except with our written consent. The same condition applies to supplies rejected by us parts similar to parts manufactured for us; should not be manufactured by you.
7. No upward revision of price will be permitted during the period of contract unless agreed by us.
8. Terms & condition stated in our purchase/subcontract will be final until the supplier has our written consent to his terms & conditions if any stated in his order acceptance letter.
9. Any letter sent by prepaid registered post to the address given in this order shall be deemed to have been received by party within 3 days of dispatch thereof; irrespective of fact whether the said letter is or is not in fact received by party so addressed.
10. The company reserves the right to cancel & terminate the contract. If prevented by any intervention or control by government authorities or any other cause beyond the control of the company where by company is unable to make use the materials ordered by stoppage suspension of production or otherwise.
11. Local civil court shall have the jurisdiction to try any dispute concerning all our purchase/subcontract.
12. The material should be properly packed to avoid any kind of damage or formation of rust during transportation or storage.
13. Strict adherence to terms of delivery is absolutely essential. The company reserves the right to treat the order as cancelled in the event of your non-compliance of delivery schedule agreed & material will be brought from open market at your risk & cost. Time of delivery shall be essence of contract.
14. Demurrage, penalties etc. shall be levied on account of delay in delivery, dispatch or railway/lorry receipts, advance of invoice & challans or any other shipping documents or for any other reason for which the company is not responsible will be to the supplier's account & recoverable from him.
15. The material must be dispatched by the mode or transport & to the destination mentioned in this order. In case partial suppliers our prior approval must be obtained.
16. If transport arrangement is made by RSB for collection & dispatch of components it will be totally the supplier's risk RSB is not responsible for any shortages damages in such Arrangement supplier should send their representative with each consignment for collection & delivery to ensure safe transit of material.
17. Supplier shall give advance information to buyer in writing for all specification change design changes as well as major changes in processing location of manufacturing applying to goods covered by this Purchase order.
18. All vehicles used for transportation of material should comply to the central motor & vehicle rules act as applicable from time to time. The transporter is required to carry PUC vehicle fitness certificate of transportation vehicle during delivery.
19. Supplier should inform dispatch details immediately after dispatch.
20. Material supplied by seller shall satisfy current Govt. & environmental (ISO 14001:2015) (OHSAS 18001:2007) constraints on restricted toxic & hazardous materials.
21. Supplier shall ensure coverage of transit insurance for material.
22. Supplier shall protect the third party trade secret or proprietary information for material or copy rights supplied by RSB. Failure to do so will result in PO being cancelled with immediate effect.

PAYMENT

1. Payment will be made as stipulated in this order, if the payment is agreed to be made against document through Bank. All bank charges involved shall be borne by the Supplier. Failure by the Supplier to advice his banker to recover all bank charges from supplier. Will result in non-retirement of documents at his own risk and cost.
2. All payments will be done as per applicable RSB policies.
3. No charges for cartage, packing etc., will admissible unless the same is specifically included in our Purchase/ Sub Contract.

SUPPLIER'S QUALITY ASSURANCE

1. All the materials, Component supplied must critically meet RSB Quality standards required as per samples, drawings, specifications or any other related instructions. The supplier shall allow, RSB's employee and authorized representatives for the purpose of inspecting manufacturing and inspection facilities, inspection of raw materials, WIP, FG, machines tools, fixtures jigs or any other items in connection with the manufacture of components for the company.

SAMPLE APPROVAL

1. No supplies should be made prior to the approval of sample unless specifically asked by us. It shall be the responsibility of the Supplier to submit samples well in time to be able to adhere strictly to the delivery schedule.

REJECTIONS

1. The decisions of the company on rejection shall be final and binding on the Supplier and this time clause shall be deemed to constitute an agreement to the contrary under the Sale of Goods Act. The company shall be entitled to reject the materials at any stage, cancel the contract and buy its requirements in the open market against the supplies. There is no rejection allowed unless specifically mentioned in the P.O. clearly.
2. It will be the liability of the Supplier to remove the rejected material within 15 days from our premises at his cost. In case rejection is not taken back within 15 days RSB is not liable to return back the rejection & no compensation will be given. In case of any rework done the components supplied by the suppliers, rework charges, handling charges, disposal charges & any other related charges as applicable will be recovered from Supplier's bill.
3. Rejection must be replaced within the delivery schedule and will be invoiced separately and not as replacement. All charges inclusive of freight and handling on replacements shall be borne by the Supplier.

WARRANTY

1. All the material supplied, should be free from any manufacturing, process defects & should be as per the drawings, Specifications. Any failure at RSB's customer end due to any deviation on quality, supplier shall be responsible for all damages, claims, recovery directly or indirectly claimed to RSB by any agency. Supplier shall reimburse all such expenses to RSB immediately without any delay on any ground. It will be the responsibility of the supplier to provide free replacement of component & assemblies which fail in the field because of material or manufacturing defects during the Warranty period or during the product life cycle, any offered by the company to its customers.

IN THE CASE OF SUB CONTRACT

1. Material Account to be submitted every month with regards to the Receipts & Supply in the prescribed format.
2. The supplier is responsible for safe custody of Company's material including the RAW Material/ Semi Finished/Finished/Tooling.
3. Periodic Physical Verification will be carried out by company's representative. During which supplier should assist in such verification.
4. The supplier has to obtain in writing the quantum to be consumed for each item supplied to him.
5. Supplier is fully responsible for quantity lifted by him till the entire quantity is supplied by him as per specification.
6. The supplier should also return the resultant scrap generated during machining. The remaining material/semi finished/finished held by supplier shall be property of company & company reserves the right to seek for return of raw material in which event the supplier shall return the same forth with.
7. No process rejection is allowed unless specified in PO specifically. In case process rejection, rejected component should be returned back to RSB on a separate delivery challan. All such components should be marked with red paint & to be supplied in a separate batch to avoid mix up. Process rejection exceeding allowed rejection % full cost of raw material shall be recovered. Line rejection at RSB is not considered in the allowed process rejection (if any). Line rejection will be recovered at full cost & rejected components will not be returned back or no scrap benefit will be passed on to supplier.
8. Supplier should ensure coverage of insurance of RSB property on their premises at their own cost.

Checked By

Authorized By

For all queries related to this order contact
www.rsbglobal.com

CORPORATE OFFICE: Ubale Nagar, Nagar Road, Wagoli, Pune, 412207, Tel : 91 20 30642100 Fax : 91 20 30642101



PURCHASE ORDER

Principal Place of Business/Bill To					Supply To						
RSB Transmissions (I) Ltd. (Forging Plant) Plot no. 1007, 1011 P.O. Uchapada Tel : 91674-2550590 Fax : 91674-2550590 Email : ranjan.jena@rsbglobal.com Website : www.rsbglobal.com GSTIN : 21AABCR3925R1Z5 PAN : AABCR3925R State Code & State : 21 ODISHA CIN : U34102PN1989PLC014807					RSB TRANSMISSIONS (I) LTD.(Cuttack) CUTTACK UNIT -1, NH-5,PLOT NO.1011,1007 MANIA,KOTSAHI,TANGI,CHOUDWAR 754022 Tel : 91674-2550590 Fax : 91674-2550590 Email : ranjan.jena@rsbglobal.com Website : www.rsbglobal.com GSTIN : 21AABCR3925R1Z5 PAN : AABCR3925R State Code & State : 21 ODISHA CIN : U34102PN1989PLC014807						
Supplier Details					PO Details						
Supplier Code : 40007025 Name : GRAMTARANG EMPLOYABILITY TRNG SERV P LTD Address : C/O ? CENTURION UNIVERSITY GRAM TARANG EMPLOYABILITY TRAINING SERVICES, AT- RAMACHANDRAPUR,JATANI , BHUBANESWAR Tel : Email : subratkumar.swain@gramtarang.org.in GSTIN : 21AABCC9406C1ZB PAN : AABCC9406C State Code & State : 21 ODISHA					Order Type/Order No : O2 / 18000397 Order Date : 13/02/2019 Revision No/ Date : 0 / 13/02/2019 Quotation No/ Date : Our Reference No. : Original Order No. : Validity Date : 31/03/2019						
No.	Item Code	Drawing No.	HSN	Quantity	Rate	GST Amount/Percentage			Request Date	Amount (Qty x Rate)	
	Description	Mod No:	SAC	UOM	Currency	IGST	CGST	SGST			
1	ZMRS0069 MACHINING CHARGES OF WELDED DIE 1214 FIN TOP		998331	1.000 EA	5371.20 INR		483.41 @ 9.0 %	483.41 @ 9.0 %	02/13/19	5371.20	
2	ZMRS0069 MACHINING CHARGES OF WELDED DIE 1214 FIN BTM		998331	1.000 EA	7308.00 INR		657.72 @ 9.0 %	657.72 @ 9.0 %	02/13/19	7308.00	
3	ZMRS0069 MACHINING CHARGES OF WELDED DIE 1214 BLK TOP		998331	1.000 EA	5472.00 INR		492.48 @ 9.0 %	492.48 @ 9.0 %	02/13/19	5472.00	
4	ZMRS0069 MACHINING CHARGES OF WELDED DIE 1214 BLK BTM		998331	1.000 EA	7092.00 INR		638.28 @ 9.0 %	638.28 @ 9.0 %	02/13/19	7092.00	
								Total :	25243.20		
								CGST Input@9%	2271.89		
								SGST Input@9%	2271.89		
								Other			
								Suspense Account			
								Suspense Setoff Account			
								Grand Total :	29786.98		
Grand Total (In Words) : RUPEES TWENTY NINE THOUSAND SEVEN HUNDRED EIGHTY SIX AND PAISE NINETY EIGHT ONLY Delivery Terms : Remarks : Payment Terms : 30 Days From Acceptance											

Checked By

Authorized By

For all queries related to this order contact
www.rsbglobal.com

CORPORATE OFFICE: Ubale Nagar, Nagar Road, Wagoli, Pune, 412207, Tel : 91 20 30642100 Fax : 91 20 30642101

TERMS & CONDITIONS**GENERAL**

1. Written acceptance of this PO or Commencement of supply/service against this PO shall constitute acceptance of this Purchase Order.
2. Delivery Challan/Invoice in duplicate should accompany all supplies made mentioning in there clearly supplier code, drawing no., part no., description of material PO no. specified in Purchase/subcontract & quantity supplied.
3. In the case of excisable goods transporter's copy should be send along with material otherwise bill/invoice will be held up. Failure to comply with this & consequent loss of mod vat credit on account of excise duty will be debited to your account where document are routed through bank send the transporter copy along with consent & enclose copy of invoice with document routed through bank. Attested/certified/Photostat copies of transporter's copy of invoice are not acceptable at all.
4. In case of subcontract item with our material failure to supply or return the material within 90 days under rule 4(5)(a) of central excise the excise duty payable in then will be debited to your account.
5. All drawings samples or technical data supplied to you by us shall be kept as secret & shall not be sold or disclosed & these shall be returned to as & when demanded. Failure to comply with this shall make you liable for breach of trust & other actions as may be deemed fit by us.
6. The items manufactured by you from the date furnished by us must not be sold or divulged by you to any other party than ourselves. If you manufacture excess quantity than our order you shall preserve the same for ultimate sale to us on our demand. Alternatively you destroy the goods so manufactured by you. By no account you will sell goods to any other party except with our written consent. The same condition applies to supplies rejected by us parts similar to parts manufactured for us; should not be manufactured by you.
7. No upward revision of price will be permitted during the period of contract unless agreed by us.
8. Terms & condition stated in our purchase/subcontract will be final until the supplier has our written consent to his terms & conditions if any stated in his order acceptance letter.
9. Any letter sent by prepaid registered post to the address given in this order shall be deemed to have been received by party within 3 days of dispatch thereof; irrespective of fact whether the said letter is or is not in fact received by party so addressed.
10. The company reserves the right to cancel & terminate the contract. If prevented by any intervention or control by government authorities or any other cause beyond the control of the company where by company is unable to make use the materials ordered by stoppage suspension of production or otherwise.
11. Local civil court shall have the jurisdiction to try any dispute concerning all our purchase/subcontract.
12. The material should be properly packed to avoid any kind of damage or formation of rust during transportation or storage.
13. Strict adherence to terms of delivery is absolutely essential. The company reserves the right to treat the order as cancelled in the event of your non-compliance of delivery schedule agreed & material will be brought from open market at your risk & cost. Time of delivery shall be essence of contract.
14. Demurrage, penalties etc. shall be levied on account of delay in delivery, dispatch or railway/lorry receipts, advance of invoice & challans or any other shipping documents or for any other reason for which the company is not responsible will be to the supplier's account & recoverable from him.
15. The material must be dispatched by the mode or transport & to the destination mentioned in this order. In case partial suppliers our prior approval must be obtained.
16. If transport arrangement is made by RSB for collection & dispatch of components it will be totally the supplier's risk RSB is not responsible for any shortages damages in such Arrangement supplier should send their representative with each consignment for collection & delivery to ensure safe transit of material.
17. Supplier shall give advance information to buyer in writing for all specification change design changes as well as major changes in processing location of manufacturing applying to goods covered by this Purchase order.
18. All vehicles used for transportation of material should comply to the central motor & vehicle rules act as applicable from time to time. The transporter is required to carry PUC vehicle fitness certificate of transportation vehicle during delivery.
19. Supplier should inform dispatch details immediately after dispatch.
20. Material supplied by seller shall satisfy current Govt. & environmental (ISO 14001:2015) (OHSAS 18001:2007) constraints on restricted toxic & hazardous materials.
21. Supplier shall ensure coverage of transit insurance for material.
22. Supplier shall protect the third party trade secret or proprietary information for material or copy rights supplied by RSB. Failure to do so will result in PO being cancelled with immediate effect.

PAYMENT

1. Payment will be made as stipulated in this order, if the payment is agreed to be made against document through Bank. All bank charges involved shall be borne by the Supplier. Failure by the Supplier to advice his banker to recover all bank charges from supplier. Will result in non-retirement of documents at his own risk and cost.
2. All payments will be done as per applicable RSB policies.
3. No charges for cartage, packing etc., will admissible unless the same is specifically included in our Purchase/ Sub Contract.

SUPPLIER'S QUALITY ASSURANCE

1. All the materials, Component supplied must critically meet RSB Quality standards required as per samples, drawings, specifications or any other related instructions. The supplier shall allow, RSB's employee and authorized representatives for the purpose of inspecting manufacturing and inspection facilities, inspection of raw materials, WIP, FG, machines tools, fixtures jigs or any other items in connection with the manufacture of components for the company.

SAMPLE APPROVAL

1. No supplies should be made prior to the approval of sample unless specifically asked by us. It shall be the responsibility of the Supplier to submit samples well in time to be able to adhere strictly to the delivery schedule.

REJECTIONS

1. The decisions of the company on rejection shall be final and binding on the Supplier and this time clause shall be deemed to constitute an agreement to the contrary under the Sale of Goods Act. The company shall be entitled to reject the materials at any stage, cancel the contract and buy its requirements in the open market against the supplies. There is no rejection allowed unless specifically mentioned in the P.O. clearly.
2. It will be the liability of the Supplier to remove the rejected material within 15 days from our premises at his cost. In case rejection is not taken back within 15 days RSB is not liable to return back the rejection & no compensation will be given. In case of any rework done the components supplied by the suppliers, rework charges, handling charges, disposal charges & any other related charges as applicable will be recovered from Supplier's bill.
3. Rejection must be replaced within the delivery schedule and will be invoiced separately and not as replacement. All charges inclusive of freight and handling on replacements shall be borne by the Supplier.

WARRANTY

1. All the material supplied, should be free from any manufacturing, process defects & should be as per the drawings, Specifications. Any failure at RSB's customer end due to any deviation on quality, supplier shall be responsible for all damages, claims, recovery directly or indirectly claimed to RSB by any agency. Supplier shall reimburse all such expenses to RSB immediately without any delay on any ground. It will be the responsibility of the supplier to provide free replacement of component & assemblies which fail in the field because of material or manufacturing defects during the Warranty period or during the product life cycle, any offered by the company to its customers.

IN THE CASE OF SUB CONTRACT

1. Material Account to be submitted every month with regards to the Receipts & Supply in the prescribed format.
2. The supplier is responsible for safe custody of Company's material including the RAW Material/ Semi Finished/Finished/Tooling.
3. Periodic Physical Verification will be carried out by company's representative. During which supplier should assist in such verification.
4. The supplier has to obtain in writing the quantum to be consumed for each item supplied to him.
5. Supplier is fully responsible for quantity lifted by him till the entire quantity is supplied by him as per specification.
6. The supplier should also return the resultant scrap generated during machining. The remaining material/semi finished/finished held by supplier shall be property of company & company reserves the right to seek for return of raw material in which event the supplier shall return the same forth with.
7. No process rejection is allowed unless specified in PO specifically. In case process rejection, rejected component should be returned back to RSB on a separate delivery challan. All such components should be marked with red paint & to be supplied in a separate batch to avoid mix up. Process rejection exceeding allowed rejection % full cost of raw material shall be recovered. Line rejection at RSB is not considered in the allowed process rejection (if any). Line rejection will be recovered at full cost & rejected components will not be returned back or no scrap benefit will be passed on to supplier.
8. Supplier should ensure coverage of insurance of RSB property on their premises at their own cost.

Checked By

Authorized By

For all queries related to this order contact
www.rsbglobal.com

CORPORATE OFFICE: Ubale Nagar, Nagar Road, Wagoli, Pune, 412207, Tel : 91 20 30642100 Fax : 91 20 30642101



PURCHASE ORDER

Principal Place of Business/Bill To					Supply To						
RSB Transmissions (I) Ltd. (Forging Plant) Plot no. 1007, 1011 P.O. Uchapada Tel : 91674-2550590 Fax : 91674-2550590 Email : ranjan.jena@rsbglobal.com Website : www.rsbglobal.com GSTIN : 21AABCR3925R1Z5 PAN : AABCR3925R State Code & State : 21 ODISHA CIN : U34102PN1989PLC014807					RSB TRANSMISSIONS (I) LTD.(Cuttack) CUTTACK UNIT -1, NH-5,PLOT NO.1011,1007 MANIA,KOTSAHI,TANGI,CHOUDWAR 754022 Tel : 91674-2550590 Fax : 91674-2550590 Email : ranjan.jena@rsbglobal.com Website : www.rsbglobal.com GSTIN : 21AABCR3925R1Z5 PAN : AABCR3925R State Code & State : 21 ODISHA CIN : U34102PN1989PLC014807						
Supplier Details					PO Details						
Supplier Code : 40007025 Name : GRAMTARANG EMPLOYABILITY TRNG SERV P LTD Address : C/O ? CENTURION UNIVERSITY GRAM TARANG EMPLOYABILITY TRAINING SERVICES, AT- RAMACHANDRAPUR,JATANI , BHUBANESWAR Tel : Email : subratkumar.swain@gramtarang.org.in GSTIN : 21AABCC9406C1ZB PAN : AABCC9406C State Code & State : 21 ODISHA					Order Type/Order No : O2 / 18000404 Order Date : 22/02/2019 Revision No/ Date : 0 / 22/02/2019 Quotation No/ Date : Our Reference No. : Original Order No. : Validity Date : 31/03/2019						
No.	Item Code	Drawing No.	HSN	Quantity	Rate	GST Amount/Percentage			Request Date	Amount (Qty x Rate)	
	Description	Mod No:	SAC	UOM	Currency	IGST	CGST	SGST			
1	ZMRS0069 MACHINING CHARGES OF WELDED DIE 1002L BLK BTM		998331	1.000 EA	4824.00 INR		434.16 @ 9.0 %	434.16 @ 9.0 %	02/22/19	4824.00	
2	ZMRS0069 MACHINING CHARGES OF WELDED DIE 1002L BLK TOP		998331	1.000 EA	5158.80 INR		464.29 @ 9.0 %	464.29 @ 9.0 %	02/22/19	5158.80	
3	ZMRS0069 MACHINING CHARGES OF WELDED DIE 1002L FIN TOP		998331	1.000 EA	4752.00 INR		427.68 @ 9.0 %	427.68 @ 9.0 %	02/22/19	4752.00	
4	ZMRS0069 MACHINING CHARGES OF WELDED DIE 1002L FIN BTM		998331	1.000 EA	5220.00 INR		469.80 @ 9.0 %	469.80 @ 9.0 %	02/22/19	5220.00	
								Total :	19954.80		
								CGST Input@9%	1795.93		
								SGST Input@9%	1795.93		
								Other			
								Suspense Account			
								Suspense Setoff Account			
								Grand Total :	23546.66		
Grand Total (In Words) : RUPEES TWENTY THREE THOUSAND FIVE HUNDRED FORTY SIX AND PAISE SIXTY SIX ONLY Delivery Terms : AS PER CAM SHEET. FOR PLANT DELIVERY. Remarks : Payment Terms : 30 Days From Acceptance											

Checked By

Authorized By

For all queries related to this order contact
www.rsbglobal.com

CORPORATE OFFICE: Ubale Nagar, Nagar Road, Wagoli, Pune, 412207, Tel : 91 20 30642100 Fax : 91 20 30642101

TERMS & CONDITIONS**GENERAL**

1. Written acceptance of this PO or Commencement of supply/service against this PO shall constitute acceptance of this Purchase Order.
2. Delivery Challan/Invoice in duplicate should accompany all supplies made mentioning in there clearly supplier code, drawing no., part no., description of material PO no. specified in Purchase/subcontract & quantity supplied.
3. In the case of excisable goods transporter's copy should be send along with material otherwise bill/invoice will be held up. Failure to comply with this & consequent loss of mod vat credit on account of excise duty will be debited to your account where document are routed through bank send the transporter copy along with consent & enclose copy of invoice with document routed through bank. Attested/certified/Photostat copies of transporter's copy of invoice are not acceptable at all.
4. In case of subcontract item with our material failure to supply or return the material within 90 days under rule 4(5)(a) of central excise the excise duty payable in then will be debited to your account.
5. All drawings samples or technical data supplied to you by us shall be kept as secret & shall not be sold or disclosed & these shall be returned to as & when demanded. Failure to comply with this shall make you liable for breach of trust & other actions as may be deemed fit by us.
6. The items manufactured by you from the date furnished by us must not be sold or divulged by you to any other party than ourselves. If you manufacture excess quantity than our order you shall preserve the same for ultimate sale to us on our demand. Alternatively you destroy the goods so manufactured by you. By no account you will sell goods to any other party except with our written consent. The same condition applies to supplies rejected by us parts similar to parts manufactured for us; should not be manufactured by you.
7. No upward revision of price will be permitted during the period of contract unless agreed by us.
8. Terms & condition stated in our purchase/subcontract will be final until the supplier has our written consent to his terms & conditions if any stated in his order acceptance letter.
9. Any letter sent by prepaid registered post to the address given in this order shall be deemed to have been received by party within 3 days of dispatch thereof; irrespective of fact whether the said letter is or is not in fact received by party so addressed.
10. The company reserves the right to cancel & terminate the contract. If prevented by any intervention or control by government authorities or any other cause beyond the control of the company where by company is unable to make use the materials ordered by stoppage suspension of production or otherwise.
11. Local civil court shall have the jurisdiction to try any dispute concerning all our purchase/subcontract.
12. The material should be properly packed to avoid any kind of damage or formation of rust during transportation or storage.
13. Strict adherence to terms of delivery is absolutely essential. The company reserves the right to treat the order as cancelled in the event of your non-compliance of delivery schedule agreed & material will be brought from open market at your risk & cost. Time of delivery shall be essence of contract.
14. Demurrage, penalties etc. shall be levied on account of delay in delivery, dispatch or railway/lorry receipts, advance of invoice & challans or any other shipping documents or for any other reason for which the company is not responsible will be to the supplier's account & recoverable from him.
15. The material must be dispatched by the mode or transport & to the destination mentioned in this order. In case partial suppliers our prior approval must be obtained.
16. If transport arrangement is made by RSB for collection & dispatch of components it will be totally the supplier's risk RSB is not responsible for any shortages damages in such Arrangement supplier should send their representative with each consignment for collection & delivery to ensure safe transit of material.
17. Supplier shall give advance information to buyer in writing for all specification change design changes as well as major changes in processing location of manufacturing applying to goods covered by this Purchase order.
18. All vehicles used for transportation of material should comply to the central motor & vehicle rules act as applicable from time to time. The transporter is required to carry PUC vehicle fitness certificate of transportation vehicle during delivery.
19. Supplier should inform dispatch details immediately after dispatch.
20. Material supplied by seller shall satisfy current Govt. & environmental (ISO 14001:2015) (OHSAS 18001:2007) constraints on restricted toxic & hazardous materials.
21. Supplier shall ensure coverage of transit insurance for material.
22. Supplier shall protect the third party trade secret or proprietary information for material or copy rights supplied by RSB. Failure to do so will result in PO being cancelled with immediate effect.

PAYMENT

1. Payment will be made as stipulated in this order, if the payment is agreed to be made against document through Bank. All bank charges involved shall be borne by the Supplier. Failure by the Supplier to advice his banker to recover all bank charges from supplier. Will result in non-retirement of documents at his own risk and cost.
2. All payments will be done as per applicable RSB policies.
3. No charges for cartage, packing etc., will admissible unless the same is specifically included in our Purchase/ Sub Contract.

SUPPLIER'S QUALITY ASSURANCE

1. All the materials, Component supplied must critically meet RSB Quality standards required as per samples, drawings, specifications or any other related instructions. The supplier shall allow, RSB's employee and authorized representatives for the purpose of inspecting manufacturing and inspection facilities, inspection of raw materials, WIP, FG, machines tools, fixtures jigs or any other items in connection with the manufacture of components for the company.

SAMPLE APPROVAL

1. No supplies should be made prior to the approval of sample unless specifically asked by us. It shall be the responsibility of the Supplier to submit samples well in time to be able to adhere strictly to the delivery schedule.

REJECTIONS

1. The decisions of the company on rejection shall be final and binding on the Supplier and this time clause shall be deemed to constitute an agreement to the contrary under the Sale of Goods Act. The company shall be entitled to reject the materials at any stage, cancel the contract and buy its requirements in the open market against the supplies. There is no rejection allowed unless specifically mentioned in the P.O. clearly.
2. It will be the liability of the Supplier to remove the rejected material within 15 days from our premises at his cost. In case rejection is not taken back within 15 days RSB is not liable to return back the rejection & no compensation will be given. In case of any rework done the components supplied by the suppliers, rework charges, handling charges, disposal charges & any other related charges as applicable will be recovered from Supplier's bill.
3. Rejection must be replaced within the delivery schedule and will be invoiced separately and not as replacement. All charges inclusive of freight and handling on replacements shall be borne by the Supplier.

WARRANTY

1. All the material supplied, should be free from any manufacturing, process defects & should be as per the drawings, Specifications. Any failure at RSB's customer end due to any deviation on quality, supplier shall be responsible for all damages, claims, recovery directly or indirectly claimed to RSB by any agency. Supplier shall reimburse all such expenses to RSB immediately without any delay on any ground. It will be the responsibility of the supplier to provide free replacement of component & assemblies which fail in the field because of material or manufacturing defects during the Warranty period or during the product life cycle, any offered by the company to its customers.

IN THE CASE OF SUB CONTRACT

1. Material Account to be submitted every month with regards to the Receipts & Supply in the prescribed format.
2. The supplier is responsible for safe custody of Company's material including the RAW Material/ Semi Finished/Finished/Tooling.
3. Periodic Physical Verification will be carried out by company's representative. During which supplier should assist in such verification.
4. The supplier has to obtain in writing the quantum to be consumed for each item supplied to him.
5. Supplier is fully responsible for quantity lifted by him till the entire quantity is supplied by him as per specification.
6. The supplier should also return the resultant scrap generated during machining. The remaining material/semi finished/finished held by supplier shall be property of company & company reserves the right to seek for return of raw material in which event the supplier shall return the same forth with.
7. No process rejection is allowed unless specified in PO specifically. In case process rejection, rejected component should be returned back to RSB on a separate delivery challan. All such components should be marked with red paint & to be supplied in a separate batch to avoid mix up. Process rejection exceeding allowed rejection % full cost of raw material shall be recovered. Line rejection at RSB is not considered in the allowed process rejection (if any). Line rejection will be recovered at full cost & rejected components will not be returned back or no scrap benefit will be passed on to supplier.
8. Supplier should ensure coverage of insurance of RSB property on their premises at their own cost.

Checked By

Authorized By

For all queries related to this order contact
www.rsbglobal.com

CORPORATE OFFICE: Ubale Nagar, Nagar Road, Wagoli, Pune, 412207, Tel : 91 20 30642100 Fax : 91 20 30642101



PURCHASE ORDER

Principal Place of Business/Bill To					Supply To						
RSB Transmissions (I) Ltd. (Forging Plant) Plot no. 1007, 1011 P.O. Uchapada Tel : 91674-2550590 Fax : 91674-2550590 Email : ranjan.jena@rsbglobal.com Website : www.rsbglobal.com GSTIN : 21AABCR3925R1Z5 PAN : AABCR3925R State Code & State : 21 ODISHA CIN : U34102PN1989PLC014807					RSB TRANSMISSIONS (I) LTD.(Cuttack) CUTTACK UNIT -1, NH-5,PLOT NO.1011,1007 MANIA,KOTSAHI,TANGI,CHOUDWAR 754022 Tel : 91674-2550590 Fax : 91674-2550590 Email : ranjan.jena@rsbglobal.com Website : www.rsbglobal.com GSTIN : 21AABCR3925R1Z5 PAN : AABCR3925R State Code & State : 21 ODISHA CIN : U34102PN1989PLC014807						
Supplier Details					PO Details						
Supplier Code : 40007025 Name : GRAMTARANG EMPLOYABILITY TRNG SERV P LTD Address : C/O ? CENTURION UNIVERSITY GRAM TARANG EMPLOYABILITY TRAINING SERVICES, AT- RAMACHANDRAPUR,JATANI , BHUBANESWAR Tel : Email : subratkumar.swain@gramtarang.org.in GSTIN : 21AABCC9406C1ZB PAN : AABCC9406C State Code & State : 21 ODISHA					Order Type/Order No : O2 / 18000405 Order Date : 22/02/2019 Revision No/ Date : 0 / 22/02/2019 Quotation No/ Date : Our Reference No. : Original Order No. : Validity Date : 31/03/2019						
No.	Item Code	Drawing No.	HSN	Quantity	Rate	GST Amount/Percentage			Request Date	Amount (Qty x Rate)	
	Description	Mod No:	SAC	UOM	Currency	IGST	CGST	SGST			
1	ZMRS0069 MACHINING CHARGES OF WELDED DIE 1026 BLK BTM		998331	1.000 EA	4554.00 INR		409.86 @ 9.0 %	409.86 @ 9.0 %	02/22/19	4554.00	
2	ZMRS0069 MACHINING CHARGES OF WELDED DIE 1026 FIN TOP		998331	1.000 EA	4546.80 INR		409.21 @ 9.0 %	409.21 @ 9.0 %	02/22/19	4546.80	
							Total :			9100.80	
							CGST Input@9%			819.07	
							SGST Input@9%			819.07	
							Other				
							Suspense Account				
							Suspense Setoff Account				
							Grand Total :			10738.94	
Grand Total (In Words) : RUPEES TEN THOUSAND SEVEN HUNDRED THIRTY EIGHT AND PAISE NINETY FOUR ONLY Delivery Terms : AS PER CAMSHEET. FOR PLANT DELIVERY. Remarks : Payment Terms : 30 Days From Acceptance											

Checked By

Authorized By

For all queries related to this order contact
www.rsbglobal.com

CORPORATE OFFICE: Ubale Nagar, Nagar Road, Wagoli, Pune, 412207, Tel : 91 20 30642100 Fax : 91 20 30642101

TERMS & CONDITIONS**GENERAL**

1. Written acceptance of this PO or Commencement of supply/service against this PO shall constitute acceptance of this Purchase Order.
2. Delivery Challan/Invoice in duplicate should accompany all supplies made mentioning in there clearly supplier code, drawing no., part no., description of material PO no. specified in Purchase/subcontract & quantity supplied.
3. In the case of excisable goods transporter's copy should be send along with material otherwise bill/invoice will be held up. Failure to comply with this & consequent loss of mod vat credit on account of excise duty will be debited to your account where document are routed through bank send the transporter copy along with consent & enclose copy of invoice with document routed through bank. Attested/certified/Photostat copies of transporter's copy of invoice are not acceptable at all.
4. In case of subcontract item with our material failure to supply or return the material within 90 days under rule 4(5)(a) of central excise the excise duty payable in then will be debited to your account.
5. All drawings samples or technical data supplied to you by us shall be kept as secret & shall not be sold or disclosed & these shall be returned to as & when demanded. Failure to comply with this shall make you liable for breach of trust & other actions as may be deemed fit by us.
6. The items manufactured by you from the date furnished by us must not be sold or divulged by you to any other party than ourselves. If you manufacture excess quantity than our order you shall preserve the same for ultimate sale to us on our demand. Alternatively you destroy the goods so manufactured by you. By no account you will sell goods to any other party except with our written consent. The same condition applies to supplies rejected by us parts similar to parts manufactured for us; should not be manufactured by you.
7. No upward revision of price will be permitted during the period of contract unless agreed by us.
8. Terms & condition stated in our purchase/subcontract will be final until the supplier has our written consent to his terms & conditions if any stated in his order acceptance letter.
9. Any letter sent by prepaid registered post to the address given in this order shall be deemed to have been received by party within 3 days of dispatch thereof; irrespective of fact whether the said letter is or is not in fact received by party so addressed.
10. The company reserves the right to cancel & terminate the contract. If prevented by any intervention or control by government authorities or any other cause beyond the control of the company where by company is unable to make use the materials ordered by stoppage suspension of production or otherwise.
11. Local civil court shall have the jurisdiction to try any dispute concerning all our purchase/subcontract.
12. The material should be properly packed to avoid any kind of damage or formation of rust during transportation or storage.
13. Strict adherence to terms of delivery is absolutely essential. The company reserves the right to treat the order as cancelled in the event of your non-compliance of delivery schedule agreed & material will be brought from open market at your risk & cost. Time of delivery shall be essence of contract.
14. Demurrage, penalties etc. shall be levied on account of delay in delivery, dispatch or railway/lorry receipts, advance of invoice & challans or any other shipping documents or for any other reason for which the company is not responsible will be to the supplier's account & recoverable from him.
15. The material must be dispatched by the mode or transport & to the destination mentioned in this order. In case partial suppliers our prior approval must be obtained.
16. If transport arrangement is made by RSB for collection & dispatch of components it will be totally the supplier's risk RSB is not responsible for any shortages damages in such Arrangement supplier should send their representative with each consignment for collection & delivery to ensure safe transit of material.
17. Supplier shall give advance information to buyer in writing for all specification change design changes as well as major changes in processing location of manufacturing applying to goods covered by this Purchase order.
18. All vehicles used for transportation of material should comply to the central motor & vehicle rules act as applicable from time to time. The transporter is required to carry PUC vehicle fitness certificate of transportation vehicle during delivery.
19. Supplier should inform dispatch details immediately after dispatch.
20. Material supplied by seller shall satisfy current Govt. & environmental (ISO 14001:2015) (OHSAS 18001:2007) constraints on restricted toxic & hazardous materials.
21. Supplier shall ensure coverage of transit insurance for material.
22. Supplier shall protect the third party trade secret or proprietary information for material or copy rights supplied by RSB. Failure to do so will result in PO being cancelled with immediate effect.

PAYMENT

1. Payment will be made as stipulated in this order, if the payment is agreed to be made against document through Bank. All bank charges involved shall be borne by the Supplier. Failure by the Supplier to advice his banker to recover all bank charges from supplier. Will result in non-retirement of documents at his own risk and cost.
2. All payments will be done as per applicable RSB policies.
3. No charges for cartage, packing etc., will admissible unless the same is specifically included in our Purchase/ Sub Contract.

SUPPLIER'S QUALITY ASSURANCE

1. All the materials, Component supplied must critically meet RSB Quality standards required as per samples, drawings, specifications or any other related instructions. The supplier shall allow, RSB's employee and authorized representatives for the purpose of inspecting manufacturing and inspection facilities, inspection of raw materials, WIP, FG, machines tools, fixtures jigs or any other items in connection with the manufacture of components for the company.

SAMPLE APPROVAL

1. No supplies should be made prior to the approval of sample unless specifically asked by us. It shall be the responsibility of the Supplier to submit samples well in time to be able to adhere strictly to the delivery schedule.

REJECTIONS

1. The decisions of the company on rejection shall be final and binding on the Supplier and this time clause shall be deemed to constitute an agreement to the contrary under the Sale of Goods Act. The company shall be entitled to reject the materials at any stage, cancel the contract and buy its requirements in the open market against the supplies. There is no rejection allowed unless specifically mentioned in the P.O. clearly.
2. It will be the liability of the Supplier to remove the rejected material within 15 days from our premises at his cost. In case rejection is not taken back within 15 days RSB is not liable to return back the rejection & no compensation will be given. In case of any rework done the components supplied by the suppliers, rework charges, handling charges, disposal charges & any other related charges as applicable will be recovered from Supplier's bill.
3. Rejection must be replaced within the delivery schedule and will be invoiced separately and not as replacement. All charges inclusive of freight and handling on replacements shall be borne by the Supplier.

WARRANTY

1. All the material supplied, should be free from any manufacturing, process defects & should be as per the drawings, Specifications. Any failure at RSB's customer end due to any deviation on quality, supplier shall be responsible for all damages, claims, recovery directly or indirectly claimed to RSB by any agency. Supplier shall reimburse all such expenses to RSB immediately without any delay on any ground. It will be the responsibility of the supplier to provide free replacement of component & assemblies which fail in the field because of material or manufacturing defects during the Warranty period or during the product life cycle, any offered by the company to its customers.

IN THE CASE OF SUB CONTRACT

1. Material Account to be submitted every month with regards to the Receipts & Supply in the prescribed format.
2. The supplier is responsible for safe custody of Company's material including the RAW Material/ Semi Finished/Finished/Tooling.
3. Periodic Physical Verification will be carried out by company's representative. During which supplier should assist in such verification.
4. The supplier has to obtain in writing the quantum to be consumed for each item supplied to him.
5. Supplier is fully responsible for quantity lifted by him till the entire quantity is supplied by him as per specification.
6. The supplier should also return the resultant scrap generated during machining. The remaining material/semi finished/finished held by supplier shall be property of company & company reserves the right to seek for return of raw material in which event the supplier shall return the same forth with.
7. No process rejection is allowed unless specified in PO specifically. In case process rejection, rejected component should be returned back to RSB on a separate delivery challan. All such components should be marked with red paint & to be supplied in a separate batch to avoid mix up. Process rejection exceeding allowed rejection % full cost of raw material shall be recovered. Line rejection at RSB is not considered in the allowed process rejection (if any). Line rejection will be recovered at full cost & rejected components will not be returned back or no scrap benefit will be passed on to supplier.
8. Supplier should ensure coverage of insurance of RSB property on their premises at their own cost.

Checked By

Authorized By

For all queries related to this order contact
www.rsbglobal.com

CORPORATE OFFICE: Ubale Nagar, Nagar Road, Wagoli, Pune, 412207, Tel : 91 20 30642100 Fax : 91 20 30642101



PURCHASE ORDER

Principal Place of Business/Bill To					Supply To					
RSB Transmissions (I) Ltd. (Forging Plant) Plot no. 1007, 1011 P.O. Uchapada Tel : 91674-2550590 Fax : 91674-2550590 Email : ranjan.jena@rsbglobal.com Website : www.rsbglobal.com GSTIN : 21AABCR3925R1Z5 PAN : AABCR3925R State Code & State : 21 ODISHA CIN : U34102PN1989PLC014807					RSB TRANSMISSIONS (I) LTD.(Cuttack) CUTTACK UNIT -1, NH-5,PLOT NO.1011,1007 MANIA,KOTSAHI,TANGI,CHOUDWAR 754022 Tel : 91674-2550590 Fax : 91674-2550590 Email : ranjan.jena@rsbglobal.com Website : www.rsbglobal.com GSTIN : 21AABCR3925R1Z5 PAN : AABCR3925R State Code & State : 21 ODISHA CIN : U34102PN1989PLC014807					
Supplier Details					PO Details					
Supplier Code : 40007025 Name : GRAMTARANG EMPLOYABILITY TRNG SERV P LTD Address : C/O ? CENTURION UNIVERSITY GRAM TARANG EMPLOYABILITY TRAINING SERVICES, AT- RAMACHANDRAPUR,JATANI , BHUBANESWAR Tel : Email : subratkumar.swain@gramtarang.org.in GSTIN : 21AABCC9406C1ZB PAN : AABCC9406C State Code & State : 21 ODISHA					Order Type/Order No : OS / 18000024 Order Date : 07/23/18 Revision No/ Date : 0 / 07/23/18 Quotation No/ Date : Our Reference No. : AS PER CAM SHEET Original Order No. : Validity Date : 12/31/18					
No.	Item Code	Drawing No.	HSN	Quantity	Rate	GST Amount/Percentage			Request Date	Amount (Qty x Rate)
	Description	Mod No:	SAC	UOM	Currency	IGST	CGST	SGST		
1	PTRPD1808*P10 TRIMMER PUNCH D1808		82073000	1.000 EA	3708.00 INR		333.72 @ 9.0 %	333.72 @ 9.0 %	07/23/18	3708.00
2	PTRPLD1808*OP10 TRIM PUNCH PLATE D1808		82073000	1.000 EA	720.00 INR		64.80 @ 9.0 %	64.80 @ 9.0 %	07/23/18	720.00
									Total :	4428.00
									CGST Input@9%	398.52
									SGST Input@9%	398.52
									Other	
									Suspense Account	
									Suspense Setoff Account	
									Grand Total :	5225.04
Grand Total (In Words) : Rupees Five Thousand Two Hundred Twenty Five and paise Four Only. Delivery Terms : EX-WORKS. Remarks : Payment Terms : 30 Days From Acceptance										

Checked By

Authorized By

For all queries related to this order contact
www.rsbglobal.com

CORPORATE OFFICE: Ubale Nagar, Nagar Road, Wagoli, Pune, 412207, Tel : 91 20 30642100 Fax : 91 20 30642101

TERMS & CONDITIONS**GENERAL**

1. Written acceptance of this PO or Commencement of supply/service against this PO shall constitute acceptance of this Purchase Order.
2. Delivery Challan/Invoice in duplicate should accompany all supplies made mentioning in there clearly supplier code, drawing no., part no., description of material PO no. specified in Purchase/subcontract & quantity supplied.
3. In the case of excisable goods transporter's copy should be send along with material otherwise bill/invoice will be held up. Failure to comply with this & consequent loss of mod vat credit on account of excise duty will be debited to your account where document are routed through bank send the transporter copy along with consent & enclose copy of invoice with document routed through bank. Attested/certified/Photostat copies of transporter's copy of invoice are not acceptable at all.
4. In case of subcontract item with our material failure to supply or return the material within 90 days under rule 4(5)(a) of central excise the excise duty payable in then will be debited to your account.
5. All drawings samples or technical data supplied to you by us shall be kept as secret & shall not be sold or disclosed & these shall be returned to as & when demanded. Failure to comply with this shall make you liable for breach of trust & other actions as may be deemed fit by us.
6. The items manufactured by you from the date furnished by us must not be sold or divulged by you to any other party than ourselves. If you manufacture excess quantity than our order you shall preserve the same for ultimate sale to us on our demand. Alternatively you destroy the goods so manufactured by you. By no account you will sell goods to any other party except with our written consent. The same condition applies to supplies rejected by us parts similar to parts manufactured for us; should not be manufactured by you.
7. No upward revision of price will be permitted during the period of contract unless agreed by us.
8. Terms & condition stated in our purchase/subcontract will be final until the supplier has our written consent to his terms & conditions if any stated in his order acceptance letter.
9. Any letter sent by prepaid registered post to the address given in this order shall be deemed to have been received by party within 3 days of dispatch thereof; irrespective of fact whether the said letter is or is not in fact received by party so addressed.
10. The company reserves the right to cancel & terminate the contract. If prevented by any intervention or control by government authorities or any other cause beyond the control of the company where by company is unable to make use the materials ordered by stoppage suspension of production or otherwise.
11. Local civil court shall have the jurisdiction to try any dispute concerning all our purchase/subcontract.
12. The material should be properly packed to avoid any kind of damage or formation of rust during transportation or storage.
13. Strict adherence to terms of delivery is absolutely essential. The company reserves the right to treat the order as cancelled in the event of your non-compliance of delivery schedule agreed & material will be brought from open market at your risk & cost. Time of delivery shall be essence of contract.
14. Demurrage, penalties etc. shall be levied on account of delay in delivery, dispatch or railway/lorry receipts, advance of invoice & challans or any other shipping documents or for any other reason for which the company is not responsible will be to the supplier's account & recoverable from him.
15. The material must be dispatched by the mode or transport & to the destination mentioned in this order. In case partial suppliers our prior approval must be obtained.
16. If transport arrangement is made by RSB for collection & dispatch of components it will be totally the supplier's risk RSB is not responsible for any shortages damages in such Arrangement supplier should send their representative with each consignment for collection & delivery to ensure safe transit of material.
17. Supplier shall give advance information to buyer in writing for all specification change design changes as well as major changes in processing location of manufacturing applying to goods covered by this Purchase order.
18. All vehicles used for transportation of material should comply to the central motor & vehicle rules act as applicable from time to time. The transporter is required to carry PUC vehicle fitness certificate of transportation vehicle during delivery.
19. Supplier should inform dispatch details immediately after dispatch.
20. Material supplied by seller shall satisfy current Govt. & environmental (ISO 14001-2004) & safety (OHSAS-18001-2007) constraints on restricted toxic & hazardous materials.
21. Supplier shall ensure coverage of transit insurance for material.
22. Supplier shall protect the third party trade secret or proprietary information for material or copy rights supplied by RSB. Failure to do so will result in PO being cancelled with immediate effect.

PAYMENT

1. Payment will be made as stipulated in this order, if the payment is agreed to be made against document through Bank. All bank charges involved shall be borne by the Supplier. Failure by the Supplier to advice his banker to recover all bank charges from supplier. Will result is non-retirement of documents at his own risk and cost.
2. All payments will be done as per applicable RSB policies.
3. No charges for cartage, packing etc., will admissible unless the same is specifically included in our Purchase/ Sub Contract.

SUPPLIER'S QUALITY ASSURANCE

1. All the materials, Component supplied must critically meet RSB Quality standards required as per samples, drawings, specifications or any other related instructions. The supplier shall allow, RSB's employee and authorized representatives for the purpose of inspecting manufacturing and inspection facilities, inspection of raw materials, WIP, FG, machines tools, fixtures jigs or any other items in connection with the manufacture of components for the company.

SAMPLE APPROVAL

1. No supplies should be made prior to the approval of sample unless specifically asked by us. It shall be the responsibility of the Supplier to submit samples well in time to be able to adhere strictly to the delivery schedule.

REJECTIONS

1. The decisions of the company on rejection shall be final and binding on the Supplier and this time clause shall be deemed to constitute an agreement to the contrary under the Sale of Goods Act. The company shall be entitled to reject the materials at any stage, cancel the contract and buy its requirements in the open market against the supplies. There is no rejection allowed unless specifically mentioned in the P.O. clearly.
2. It will be the liability of the Supplier to remove the rejected material within 15 days from our premises at his cost. In case rejection is not taken back within 15 days RSB is not liable to return back the rejection & no compensation will be given. In case of any rework done the components supplied by the suppliers, rework charges, handling charges, disposal charges & any other related charges as applicable will be recovered from Supplier's bill.
3. Rejection must be replaced within the delivery schedule and will be invoiced separately and not as replacement. All charges inclusive of freight and handling on replacements shall be borne by the Supplier.

WARRANTY

1. All the material supplied, should be free from any manufacturing, process defects & should be as per the drawings, Specifications. Any failure at RSB's customer end due to any deviation on quality, supplier shall be responsible for all damages, claims, recovery directly or indirectly claimed to RSB by any agency. Supplier shall reimburse all such expenses to RSB immediately without any delay on any ground. It will be the responsibility of the supplier to provide free replacement of component & assemblies which fail in the field because of material or manufacturing defects during the Warranty period or during the product life cycle, any offered by the company to its customers.

IN THE CASE OF SUB CONTRACT

1. Material Account to be submitted every month with regards to the Receipts & Supply in the prescribed format.
2. The supplier is responsible for safe custody of Company's material including the RAW Material/ Semi Finished/Finished/Tooling.
3. Periodic Physical Verification will be carried out by company's representative. During which supplier should assist in such verification.
4. The supplier has to obtain in writing the quantum to be consumed for each item supplied to him.
5. Supplier is fully responsible for quantity lifted by him till the entire quantity is supplied by him as per specification.
6. The supplier should also return the resultant scrap generated during machining. The remaining material/semi finished/finished held by supplier shall be property of company & company reserves the right to seek for return of raw material in which event the supplier shall return the same forth with.
7. No process rejection is allowed unless specified in PO specifically. In case process rejection, rejected component should be returned back to RSB on a separate delivery challan. All such components should be marked with red paint & to be supplied in a separate batch to avoid mix up. Process rejection exceeding allowed rejection % full cost of raw material shall be recovered. Line rejection at RSB is not considered in the allowed process rejection (if any). Line rejection will be recovered at full cost & rejected components will not be returned back or no scrap benefit will be passed on to supplier.
8. Supplier should ensure coverage of insurance of RSB property on their premises at their own cost.

Checked By

Authorized By

For all queries related to this order contact
www.rsbglobal.com

CORPORATE OFFICE: Ubale Nagar, Nagar Road, Wagoli, Pune, 412207, Tel : 91 20 30642100 Fax : 91 20 30642101



PURCHASE ORDER

Principal Place of Business/Bill To	Supply To
RSB Transmissions (I) Ltd. (Forging Plant) Plot no. 1007, 1011 P.O. Uchapada Tel : 91674-2550590 Fax : 91674-2550590 Email : ranjan.jena@rsbglobal.com Website : www.rsbglobal.com GSTIN : 21AABCR3925R1Z5 PAN : AABCR3925R State Code & State : 21 ODISHA CIN : U34102PN1989PLC014807	RSB TRANSMISSIONS (I) LTD.(Cuttack) CUTTACK UNIT -1, NH-5,PLOT NO.1011,1007 MANIA,KOTSAHI,TANGI,CHOUDWAR 754022 Tel : 91674-2550590 Fax : 91674-2550590 Email : ranjan.jena@rsbglobal.com Website : www.rsbglobal.com GSTIN : 21AABCR3925R1Z5 PAN : AABCR3925R State Code & State : 21 ODISHA CIN : U34102PN1989PLC014807

Supplier Details	PO Details
Supplier Code : 40007025 Name : GRAMTARANG EMPLOYABILITY TRNG SERV P LTD Address : C/O ? CENTURION UNIVERSITY GRAM TARANG EMPLOYABILITY TRAINING SERVICES, AT- RAMACHANDRAPUR,JATANI , BHUBANESWAR Tel : Email : subratkumar.swain@gramtarang.org.in GSTIN : 21AABCC9406C1ZB PAN : AABCC9406C State Code & State : 21 ODISHA	Order Type/Order No : OS / 18000029 Order Date : 07/26/18 Revision No/ Date : 0 / 07/31/18 Quotation No/ Date : Our Reference No. : AS PER CAM SHEET Original Order No. : Validity Date : 01/31/19

No.	Item Code	Drawing No.	HSN	Quantity	Rate	GST Amount/Percentage			Request Date	Amount (Qty x Rate)
	Description	Mod No:	SAC	UOM	Currency	IGST	CGST	SGST		
1	PTRD1809*OP10 TRIMMER DIE D1809		82073000	1.000 EA	5097.60 INR		458.78 @ 9.0 %	458.78 @ 9.0 %	07/26/18	5097.60
2	PTRD1810*OP10 TRIMMER DIE D1810		82073000	1.000 EA	6224.40 INR		560.20 @ 9.0 %	560.20 @ 9.0 %	07/26/18	6224.40
3	PTRPD1810*P10 TRIMMER PUNCH D1810		82073000	1.000 EA	720.00 INR		64.80 @ 9.0 %	64.80 @ 9.0 %	07/26/18	720.00
4	PTRPLD1810*OP10 TRIM PUNCH PLATE D1810		82073000	1.000 EA	3600.00 INR		324.00 @ 9.0 %	324.00 @ 9.0 %	07/26/18	3600.00
5	PTRPLD1809*OP10 TRIM PUNCH PLATE D1809		82073000	1.000 EA	720.00 INR		64.80 @ 9.0 %	64.80 @ 9.0 %	07/26/18	720.00
6	PTRD1811*OP10 TRIMMER DIE D1811		82073000	1.000 EA	5238.00 INR		471.42 @ 9.0 %	471.42 @ 9.0 %	07/26/18	5238.00
7	PTRPD1812*P10 TRIMMER PUNCH D1812		82073000	1.000 EA	2620.80 INR		235.87 @ 9.0 %	235.87 @ 9.0 %	07/26/18	2620.80

Checked By

Authorized By

For all queries related to this order contact
www.rsbglobal.com

CORPORATE OFFICE: Ubale Nagar, Nagar Road, Wagoli, Pune, 412207, Tel : 91 20 30642100 Fax : 91 20 30642101



PURCHASE ORDER

8	PTRD1812*OP10 TRIMMER DIE D1812		82073000	1.000 EA	4305.60 INR		387.50 @ 9.0 %	387.50 @ 9.0 %	07/26/18	4305.60
9	PTRPLD1812*OP10 TRIM PUNCH PLATE D1812		82073000	1.000 EA	720.00 INR		64.80 @ 9.0 %	64.80 @ 9.0 %	07/26/18	720.00
10	PTRPD1809*P10 TRIMMER PUNCH D1809		82073000	1.000 EA	2998.80 INR		269.89 @ 9.0 %	269.89 @ 9.0 %	07/26/18	2998.80
11	PTRPLD1811*OP10 TRIM PUNCH PLATE D1811		82073000	1.000 EA	720.00 INR		64.80 @ 9.0 %	64.80 @ 9.0 %	07/26/18	720.00
12	PTRPD1811*P10 TRIMMER PUNCH D1811		82073000	1.000 EA	3304.80 INR		297.43 @ 9.0 %	297.43 @ 9.0 %	07/26/18	3304.80

									Total :	36270.00
									CGST Input@9%	3264.30
									SGST Input@9%	3264.30
									Other	
									Suspense Account	
									Suspense Setoff Account	
									Grand Total :	42798.60

Grand Total (In Words) : Rupees Forty Two Thousand Seven Hundred Ninety Eight and paise Sixty Only.
 Delivery Terms : EX-WORKS.
 Remarks :
 Payment Terms : 30 Days From Acceptance

Checked By

Authorized By

For all queries related to this order contact
www.rsbglobal.com

CORPORATE OFFICE: Ubale Nagar, Nagar Road, Wagoli, Pune, 412207, Tel : 91 20 30642100 Fax : 91 20 30642101

TERMS & CONDITIONS**GENERAL**

1. Written acceptance of this PO or Commencement of supply/service against this PO shall constitute acceptance of this Purchase Order.
2. Delivery Challan/Invoice in duplicate should accompany all supplies made mentioning in there clearly supplier code, drawing no., part no., description of material PO no. specified in Purchase/subcontract & quantity supplied.
3. In the case of excisable goods transporter's copy should be send along with material otherwise bill/invoice will be held up. Failure to comply with this & consequent loss of mod vat credit on account of excise duty will be debited to your account where document are routed through bank send the transporter copy along with consent & enclose copy of invoice with document routed through bank. Attested/certified/Photostat copies of transporter's copy of invoice are not acceptable at all.
4. In case of subcontract item with our material failure to supply or return the material within 90 days under rule 4(5)(a) of central excise the excise duty payable in then will be debited to your account.
5. All drawings samples or technical data supplied to you by us shall be kept as secret & shall not be sold or disclosed & these shall be returned to as & when demanded. Failure to comply with this shall make you liable for breach of trust & other actions as may be deemed fit by us.
6. The items manufactured by you from the date furnished by us must not be sold or divulged by you to any other party than ourselves. If you manufacture excess quantity than our order you shall preserve the same for ultimate sale to us on our demand. Alternatively you destroy the goods so manufactured by you. By no account you will sell goods to any other party except with our written consent. The same condition applies to supplies rejected by us parts similar to parts manufactured for us; should not be manufactured by you.
7. No upward revision of price will be permitted during the period of contract unless agreed by us.
8. Terms & condition stated in our purchase/subcontract will be final until the supplier has our written consent to his terms & conditions if any stated in his order acceptance letter.
9. Any letter sent by prepaid registered post to the address given in this order shall be deemed to have been received by party within 3 days of dispatch thereof; irrespective of fact whether the said letter is or is not in fact received by party so addressed.
10. The company reserves the right to cancel & terminate the contract. If prevented by any intervention or control by government authorities or any other cause beyond the control of the company where by company is unable to make use the materials ordered by stoppage suspension of production or otherwise.
11. Local civil court shall have the jurisdiction to try any dispute concerning all our purchase/subcontract.
12. The material should be properly packed to avoid any kind of damage or formation of rust during transportation or storage.
13. Strict adherence to terms of delivery is absolutely essential. The company reserves the right to treat the order as cancelled in the event of your non-compliance of delivery schedule agreed & material will be brought from open market at your risk & cost. Time of delivery shall be essence of contract.
14. Demurrage, penalties etc. shall be levied on account of delay in delivery, dispatch or railway/lorry receipts, advance of invoice & challans or any other shipping documents or for any other reason for which the company is not responsible will be to the supplier's account & recoverable from him.
15. The material must be dispatched by the mode or transport & to the destination mentioned in this order. In case partial suppliers our prior approval must be obtained.
16. If transport arrangement is made by RSB for collection & dispatch of components it will be totally the supplier's risk RSB is not responsible for any shortages damages in such Arrangement supplier should send their representative with each consignment for collection & delivery to ensure safe transit of material.
17. Supplier shall give advance information to buyer in writing for all specification change design changes as well as major changes in processing location of manufacturing applying to goods covered by this Purchase order.
18. All vehicles used for transportation of material should comply to the central motor & vehicle rules act as applicable from time to time. The transporter is required to carry PUC vehicle fitness certificate of transportation vehicle during delivery.
19. Supplier should inform dispatch details immediately after dispatch.
20. Material supplied by seller shall satisfy current Govt. & environmental (ISO 14001-2004) & safety (OHSAS-18001-2007) constraints on restricted toxic & hazardous materials.
21. Supplier shall ensure coverage of transit insurance for material.
22. Supplier shall protect the third party trade secret or proprietary information for material or copy rights supplied by RSB. Failure to do so will result in PO being cancelled with immediate effect.

PAYMENT

1. Payment will be made as stipulated in this order, if the payment is agreed to be made against document through Bank. All bank charges involved shall be borne by the Supplier. Failure by the Supplier to advice his banker to recover all bank charges from supplier. Will result is non-retirement of documents at his own risk and cost.
2. All payments will be done as per applicable RSB policies.
3. No charges for cartage, packing etc., will admissible unless the same is specifically included in our Purchase/ Sub Contract.

SUPPLIER'S QUALITY ASSURANCE

1. All the materials, Component supplied must critically meet RSB Quality standards required as per samples, drawings, specifications or any other related instructions. The supplier shall allow, RSB's employee and authorized representatives for the purpose of inspecting manufacturing and inspection facilities, inspection of raw materials, WIP, FG, machines tools, fixtures jigs or any other items in connection with the manufacture of components for the company.

SAMPLE APPROVAL

1. No supplies should be made prior to the approval of sample unless specifically asked by us. It shall be the responsibility of the Supplier to submit samples well in time to be able to adhere strictly to the delivery schedule.

REJECTIONS

1. The decisions of the company on rejection shall be final and binding on the Supplier and this time clause shall be deemed to constitute an agreement to the contrary under the Sale of Goods Act. The company shall be entitled to reject the materials at any stage, cancel the contract and buy its requirements in the open market against the supplies. There is no rejection allowed unless specifically mentioned in the P.O. clearly.
2. It will be the liability of the Supplier to remove the rejected material within 15 days from our premises at his cost. In case rejection is not taken back within 15 days RSB is not liable to return back the rejection & no compensation will be given. In case of any rework done the components supplied by the suppliers, rework charges, handling charges, disposal charges & any other related charges as applicable will be recovered from Supplier's bill.
3. Rejection must be replaced within the delivery schedule and will be invoiced separately and not as replacement. All charges inclusive of freight and handling on replacements shall be borne by the Supplier.

WARRANTY

1. All the material supplied, should be free from any manufacturing, process defects & should be as per the drawings, Specifications. Any failure at RSB's customer end due to any deviation on quality, supplier shall be responsible for all damages, claims, recovery directly or indirectly claimed to RSB by any agency. Supplier shall reimburse all such expenses to RSB immediately without any delay on any ground. It will be the responsibility of the supplier to provide free replacement of component & assemblies which fail in the field because of material or manufacturing defects during the Warranty period or during the product life cycle, any offered by the company to its customers.

IN THE CASE OF SUB CONTRACT

1. Material Account to be submitted every month with regards to the Receipts & Supply in the prescribed format.
2. The supplier is responsible for safe custody of Company's material including the RAW Material/ Semi Finished/Finished/Tooling.
3. Periodic Physical Verification will be carried out by company's representative. During which supplier should assist in such verification.
4. The supplier has to obtain in writing the quantum to be consumed for each item supplied to him.
5. Supplier is fully responsible for quantity lifted by him till the entire quantity is supplied by him as per specification.
6. The supplier should also return the resultant scrap generated during machining. The remaining material/semi finished/finished held by supplier shall be property of company & company reserves the right to seek for return of raw material in which event the supplier shall return the same forth with.
7. No process rejection is allowed unless specified in PO specifically. In case process rejection, rejected component should be returned back to RSB on a separate delivery challan. All such components should be marked with red paint & to be supplied in a separate batch to avoid mix up. Process rejection exceeding allowed rejection % full cost of raw material shall be recovered. Line rejection at RSB is not considered in the allowed process rejection (if any). Line rejection will be recovered at full cost & rejected components will not be returned back or no scrap benefit will be passed on to supplier.
8. Supplier should ensure coverage of insurance of RSB property on their premises at their own cost.

Checked By

Authorized By

For all queries related to this order contact
www.rsbglobal.com

CORPORATE OFFICE: Ubale Nagar, Nagar Road, Wagoli, Pune, 412207, Tel : 91 20 30642100 Fax : 91 20 30642101



PURCHASE ORDER

Principal Place of Business/Bill To					Supply To					
RSB Transmissions (I) Ltd. (Forging Plant) Plot no. 1007, 1011 P.O. Uchapada Tel : 91674-2550590 Fax : 91674-2550590 Email : ranjan.jena@rsbglobal.com Website : www.rsbglobal.com GSTIN : 21AABCR3925R1Z5 PAN : AABCR3925R State Code & State : 21 ODISHA CIN : U34102PN1989PLC014807					RSB TRANSMISSIONS (I) LTD.(Cuttack) CUTTACK UNIT -1, NH-5,PLOT NO.1011,1007 MANIA,KOTSAHI,TANGI,CHOUDWAR 754022 Tel : 91674-2550590 Fax : 91674-2550590 Email : ranjan.jena@rsbglobal.com Website : www.rsbglobal.com GSTIN : 21AABCR3925R1Z5 PAN : AABCR3925R State Code & State : 21 ODISHA CIN : U34102PN1989PLC014807					
Supplier Details					PO Details					
Supplier Code : 40007025 Name : GRAMTARANG EMPLOYABILITY TRNG SERV P LTD Address : C/O ? CENTURION UNIVERSITY GRAM TARANG EMPLOYABILITY TRAINING SERVICES, AT- RAMACHANDRAPUR,JATANI , BHUBANESWAR Tel : Email : subratkumar.swain@gramtarang.org.in GSTIN : 21AABCC9406C1ZB PAN : AABCC9406C State Code & State : 21 ODISHA					Order Type/Order No : OS / 18000034 Order Date : 08/24/18 Revision No/ Date : 0 / 08/27/18 Quotation No/ Date : Our Reference No. : as per cam sheet Original Order No. : Validity Date : 01/31/19					
No.	Item Code	Drawing No.	HSN	Quantity	Rate	GST Amount/Percentage			Request Date	Amount (Qty x Rate)
	Description	Mod No:	SAC	UOM	Currency	IGST	CGST	SGST		
1	PTRPD1811*OP10 TRIMMER PUNCH D1811		82073000	1.000 EA	3304.80 INR		297.43 @ 9.0 %	297.43 @ 9.0 %	08/24/18	3304.80
2	PTRPD1812*OP10 TRIMMER PUNCH D1812		82073000	1.000 EA	2620.80 INR		235.87 @ 9.0 %	235.87 @ 9.0 %	08/24/18	2620.80
3	PTRPD1809*OP10 TRIMMER PUNCH D1809		82073000	1.000 EA	2998.80 INR		269.89 @ 9.0 %	269.89 @ 9.0 %	08/24/18	2998.80
									Total :	8924.40
									CGST Input@9%	803.20
									SGST Input@9%	803.20
									Other	
									Suspense Account	
									Suspense Setoff Account	
									Grand Total :	10530.79
Grand Total (In Words) : Rupees Ten Thousand Five Hundred Thirty and paise Seventy Nine Only. Delivery Terms : ex-works. Remarks : Payment Terms : 30 Days From Acceptance										

Checked By

Authorized By

For all queries related to this order contact
www.rsbglobal.com

CORPORATE OFFICE: Ubale Nagar, Nagar Road, Wagoli, Pune, 412207, Tel : 91 20 30642100 Fax : 91 20 30642101

TERMS & CONDITIONS**GENERAL**

1. Written acceptance of this PO or Commencement of supply/service against this PO shall constitute acceptance of this Purchase Order.
2. Delivery Challan/Invoice in duplicate should accompany all supplies made mentioning in there clearly supplier code, drawing no., part no., description of material PO no. specified in Purchase/subcontract & quantity supplied.
3. In the case of excisable goods transporter's copy should be send along with material otherwise bill/invoice will be held up. Failure to comply with this & consequent loss of mod vat credit on account of excise duty will be debited to your account where document are routed through bank send the transporter copy along with consent & enclose copy of invoice with document routed through bank. Attested/certified/Photostat copies of transporter's copy of invoice are not acceptable at all.
4. In case of subcontract item with our material failure to supply or return the material within 90 days under rule 4(5)(a) of central excise the excise duty payable in then will be debited to your account.
5. All drawings samples or technical data supplied to you by us shall be kept as secret & shall not be sold or disclosed & these shall be returned to as & when demanded. Failure to comply with this shall make you liable for breach of trust & other actions as may be deemed fit by us.
6. The items manufactured by you from the date furnished by us must not be sold or divulged by you to any other party than ourselves. If you manufacture excess quantity than our order you shall preserve the same for ultimate sale to us on our demand. Alternatively you destroy the goods so manufactured by you. By no account you will sell goods to any other party except with our written consent. The same condition applies to supplies rejected by us parts similar to parts manufactured for us; should not be manufactured by you.
7. No upward revision of price will be permitted during the period of contract unless agreed by us.
8. Terms & condition stated in our purchase/subcontract will be final until the supplier has our written consent to his terms & conditions if any stated in his order acceptance letter.
9. Any letter sent by prepaid registered post to the address given in this order shall be deemed to have been received by party within 3 days of dispatch thereof; irrespective of fact whether the said letter is or is not in fact received by party so addressed.
10. The company reserves the right to cancel & terminate the contract. If prevented by any intervention or control by government authorities or any other cause beyond the control of the company where by company is unable to make use the materials ordered by stoppage suspension of production or otherwise.
11. Local civil court shall have the jurisdiction to try any dispute concerning all our purchase/subcontract.
12. The material should be properly packed to avoid any kind of damage or formation of rust during transportation or storage.
13. Strict adherence to terms of delivery is absolutely essential. The company reserves the right to treat the order as cancelled in the event of your non-compliance of delivery schedule agreed & material will be brought from open market at your risk & cost. Time of delivery shall be essence of contract.
14. Demurrage, penalties etc. shall be levied on account of delay in delivery, dispatch or railway/lorry receipts, advance of invoice & challans or any other shipping documents or for any other reason for which the company is not responsible will be to the supplier's account & recoverable from him.
15. The material must be dispatched by the mode or transport & to the destination mentioned in this order. In case partial suppliers our prior approval must be obtained.
16. If transport arrangement is made by RSB for collection & dispatch of components it will be totally the supplier's risk RSB is not responsible for any shortages damages in such Arrangement supplier should send their representative with each consignment for collection & delivery to ensure safe transit of material.
17. Supplier shall give advance information to buyer in writing for all specification change design changes as well as major changes in processing location of manufacturing applying to goods covered by this Purchase order.
18. All vehicles used for transportation of material should comply to the central motor & vehicle rules act as applicable from time to time. The transporter is required to carry PUC vehicle fitness certificate of transportation vehicle during delivery.
19. Supplier should inform dispatch details immediately after dispatch.
20. Material supplied by seller shall satisfy current Govt. & environmental (ISO 14001-2004) & safety (OHSAS-18001-2007) constraints on restricted toxic & hazardous materials.
21. Supplier shall ensure coverage of transit insurance for material.
22. Supplier shall protect the third party trade secret or proprietary information for material or copy rights supplied by RSB. Failure to do so will result in PO being cancelled with immediate effect.

PAYMENT

1. Payment will be made as stipulated in this order, if the payment is agreed to be made against document through Bank. All bank charges involved shall be borne by the Supplier. Failure by the Supplier to advice his banker to recover all bank charges from supplier. Will result is non-retirement of documents at his own risk and cost.
2. All payments will be done as per applicable RSB policies.
3. No charges for cartage, packing etc., will admissible unless the same is specifically included in our Purchase/ Sub Contract.

SUPPLIER'S QUALITY ASSURANCE

1. All the materials, Component supplied must critically meet RSB Quality standards required as per samples, drawings, specifications or any other related instructions. The supplier shall allow, RSB's employee and authorized representatives for the purpose of inspecting manufacturing and inspection facilities, inspection of raw materials, WIP, FG, machines tools, fixtures jigs or any other items in connection with the manufacture of components for the company.

SAMPLE APPROVAL

1. No supplies should be made prior to the approval of sample unless specifically asked by us. It shall be the responsibility of the Supplier to submit samples well in time to be able to adhere strictly to the delivery schedule.

REJECTIONS

1. The decisions of the company on rejection shall be final and binding on the Supplier and this time clause shall be deemed to constitute an agreement to the contrary under the Sale of Goods Act. The company shall be entitled to reject the materials at any stage, cancel the contract and buy its requirements in the open market against the supplies. There is no rejection allowed unless specifically mentioned in the P.O. clearly.
2. It will be the liability of the Supplier to remove the rejected material within 15 days from our premises at his cost. In case rejection is not taken back within 15 days RSB is not liable to return back the rejection & no compensation will be given. In case of any rework done the components supplied by the suppliers, rework charges, handling charges, disposal charges & any other related charges as applicable will be recovered from Supplier's bill.
3. Rejection must be replaced within the delivery schedule and will be invoiced separately and not as replacement. All charges inclusive of freight and handling on replacements shall be borne by the Supplier.

WARRANTY

1. All the material supplied, should be free from any manufacturing, process defects & should be as per the drawings, Specifications. Any failure at RSB's customer end due to any deviation on quality, supplier shall be responsible for all damages, claims, recovery directly or indirectly claimed to RSB by any agency. Supplier shall reimburse all such expenses to RSB immediately without any delay on any ground. It will be the responsibility of the supplier to provide free replacement of component & assemblies which fail in the field because of material or manufacturing defects during the Warranty period or during the product life cycle, any offered by the company to its customers.

IN THE CASE OF SUB CONTRACT

1. Material Account to be submitted every month with regards to the Receipts & Supply in the prescribed format.
2. The supplier is responsible for safe custody of Company's material including the RAW Material/ Semi Finished/Finished/Tooling.
3. Periodic Physical Verification will be carried out by company's representative. During which supplier should assist in such verification.
4. The supplier has to obtain in writing the quantum to be consumed for each item supplied to him.
5. Supplier is fully responsible for quantity lifted by him till the entire quantity is supplied by him as per specification.
6. The supplier should also return the resultant scrap generated during machining. The remaining material/semi finished/finished held by supplier shall be property of company & company reserves the right to seek for return of raw material in which event the supplier shall return the same forth with.
7. No process rejection is allowed unless specified in PO specifically. In case process rejection, rejected component should be returned back to RSB on a separate delivery challan. All such components should be marked with red paint & to be supplied in a separate batch to avoid mix up. Process rejection exceeding allowed rejection % full cost of raw material shall be recovered. Line rejection at RSB is not considered in the allowed process rejection (if any). Line rejection will be recovered at full cost & rejected components will not be returned back or no scrap benefit will be passed on to supplier.
8. Supplier should ensure coverage of insurance of RSB property on their premises at their own cost.

Checked By

Authorized By

For all queries related to this order contact
www.rsbglobal.com

CORPORATE OFFICE: Ubale Nagar, Nagar Road, Wagoli, Pune, 412207, Tel : 91 20 30642100 Fax : 91 20 30642101



PURCHASE ORDER

Principal Place of Business/Bill To					Supply To						
RSB Transmissions (I) Ltd. (Forging Plant) Plot no. 1007, 1011 P.O. Uchapada Tel : 91674-2550590 Fax : 91674-2550590 Email : ranjan.jena@rsbglobal.com Website : www.rsbglobal.com GSTIN : 21AABCR3925R1Z5 PAN : AABCR3925R State Code & State : 21 ODISHA CIN : U34102PN1989PLC014807					RSB TRANSMISSIONS (I) LTD.(Cuttack) CUTTACK UNIT -1, NH-5,PLOT NO.1011,1007 MANIA,KOTSAHI,TANGI,CHOUDWAR 754022 Tel : 91674-2550590 Fax : 91674-2550590 Email : ranjan.jena@rsbglobal.com Website : www.rsbglobal.com GSTIN : 21AABCR3925R1Z5 PAN : AABCR3925R State Code & State : 21 ODISHA CIN : U34102PN1989PLC014807						
Supplier Details					PO Details						
Supplier Code : 40007025 Name : GRAMTARANG EMPLOYABILITY TRNG SERV P LTD Address : C/O ? CENTURION UNIVERSITY GRAM TARANG EMPLOYABILITY TRAINING SERVICES, AT- RAMACHANDRAPUR,JATANI , BHUBANESWAR Tel : Email : subratkumar.swain@gramtarang.org.in GSTIN : 21AABCC9406C1ZB PAN : AABCC9406C State Code & State : 21 ODISHA					Order Type/Order No : O2 / 18000430 Order Date : 11/03/2019 Revision No/ Date : 0 / 11/03/2019 Quotation No/ Date : Our Reference No. : Original Order No. : Validity Date : 31/03/2019						
No.	Item Code	Drawing No.	HSN	Quantity	Rate	GST Amount/Percentage			Request Date	Amount (Qty x Rate)	
	Description	Mod No:	SAC	UOM	Currency	IGST	CGST	SGST			
1	ZMRS0069 MACHINING CHARGES OF WELDED DIE 2001 BLK BTM		998331	1.000 EA	5364.00 INR		482.76 @ 9.0 %	482.76 @ 9.0 %	03/11/19	5364.00	
2	ZMRS0069 MACHINING CHARGES OF WELDED DIE 2001 FIN TOP		998331	1.000 EA	4971.60 INR		447.44 @ 9.0 %	447.44 @ 9.0 %	03/11/19	4971.60	
3	ZMRS0069 MACHINING CHARGES OF WELDED DIE 2001 FIN BTM		998331	1.000 EA	4824.00 INR		434.16 @ 9.0 %	434.16 @ 9.0 %	03/11/19	4824.00	
4	ZMRS0069 MACHINING CHARGES OF WELDED DIE 2001 BLK TOP		998331	1.000 EA	5043.60 INR		453.92 @ 9.0 %	453.92 @ 9.0 %	03/11/19	5043.60	
									Total :	20203.20	
									CGST Input@9%	1818.29	
									SGST Input@9%	1818.29	
									Other		
									Suspense Account		
									Suspense Setoff Account		
									Grand Total :	23839.78	
Grand Total (In Words) : RUPEES TWENTY THREE THOUSAND EIGHT HUNDRED THIRTY NINE AND PAISE SEVENTY EIGHT ONLY Delivery Terms : EX-WORKS. Remarks : Payment Terms : 30 Days From Acceptance											

Checked By

Authorized By

For all queries related to this order contact
www.rsbglobal.com

CORPORATE OFFICE: Ubale Nagar, Nagar Road, Wagoli, Pune, 412207, Tel : 91 20 30642100 Fax : 91 20 30642101

TERMS & CONDITIONS**GENERAL**

1. Written acceptance of this PO or Commencement of supply/service against this PO shall constitute acceptance of this Purchase Order.
2. Delivery Challan/Invoice in duplicate should accompany all supplies made mentioning in there clearly supplier code, drawing no., part no., description of material PO no. specified in Purchase/subcontract & quantity supplied.
3. In the case of excisable goods transporter's copy should be send along with material otherwise bill/invoice will be held up. Failure to comply with this & consequent loss of mod vat credit on account of excise duty will be debited to your account where document are routed through bank send the transporter copy along with consent & enclose copy of invoice with document routed through bank. Attested/certified/Photostat copies of transporter's copy of invoice are not acceptable at all.
4. In case of subcontract item with our material failure to supply or return the material within 90 days under rule 4(5)(a) of central excise the excise duty payable in then will be debited to your account.
5. All drawings samples or technical data supplied to you by us shall be kept as secret & shall not be sold or disclosed & these shall be returned to as & when demanded. Failure to comply with this shall make you liable for breach of trust & other actions as may be deemed fit by us.
6. The items manufactured by you from the date furnished by us must not be sold or divulged by you to any other party than ourselves. If you manufacture excess quantity than our order you shall preserve the same for ultimate sale to us on our demand. Alternatively you destroy the goods so manufactured by you. By no account you will sell goods to any other party except with our written consent. The same condition applies to supplies rejected by us parts similar to parts manufactured for us; should not be manufactured by you.
7. No upward revision of price will be permitted during the period of contract unless agreed by us.
8. Terms & condition stated in our purchase/subcontract will be final until the supplier has our written consent to his terms & conditions if any stated in his order acceptance letter.
9. Any letter sent by prepaid registered post to the address given in this order shall be deemed to have been received by party within 3 days of dispatch thereof; irrespective of fact whether the said letter is or is not in fact received by party so addressed.
10. The company reserves the right to cancel & terminate the contract. If prevented by any intervention or control by government authorities or any other cause beyond the control of the company where by company is unable to make use the materials ordered by stoppage suspension of production or otherwise.
11. Local civil court shall have the jurisdiction to try any dispute concerning all our purchase/subcontract.
12. The material should be properly packed to avoid any kind of damage or formation of rust during transportation or storage.
13. Strict adherence to terms of delivery is absolutely essential. The company reserves the right to treat the order as cancelled in the event of your non-compliance of delivery schedule agreed & material will be brought from open market at your risk & cost. Time of delivery shall be essence of contract.
14. Demurrage, penalties etc. shall be levied on account of delay in delivery, dispatch or railway/lorry receipts, advance of invoice & challans or any other shipping documents or for any other reason for which the company is not responsible will be to the supplier's account & recoverable from him.
15. The material must be dispatched by the mode or transport & to the destination mentioned in this order. In case partial suppliers our prior approval must be obtained.
16. If transport arrangement is made by RSB for collection & dispatch of components it will be totally the supplier's risk RSB is not responsible for any shortages damages in such Arrangement supplier should send their representative with each consignment for collection & delivery to ensure safe transit of material.
17. Supplier shall give advance information to buyer in writing for all specification change design changes as well as major changes in processing location of manufacturing applying to goods covered by this Purchase order.
18. All vehicles used for transportation of material should comply to the central motor & vehicle rules act as applicable from time to time. The transporter is required to carry PUC vehicle fitness certificate of transportation vehicle during delivery.
19. Supplier should inform dispatch details immediately after dispatch.
20. Material supplied by seller shall satisfy current Govt. & environmental (ISO 14001:2015) (OHSAS 18001:2007) constraints on restricted toxic & hazardous materials.
21. Supplier shall ensure coverage of transit insurance for material.
22. Supplier shall protect the third party trade secret or proprietary information for material or copy rights supplied by RSB. Failure to do so will result in PO being cancelled with immediate effect.

PAYMENT

1. Payment will be made as stipulated in this order, if the payment is agreed to be made against document through Bank. All bank charges involved shall be borne by the Supplier. Failure by the Supplier to advice his banker to recover all bank charges from supplier. Will result in non-retirement of documents at his own risk and cost.
2. All payments will be done as per applicable RSB policies.
3. No charges for cartage, packing etc., will admissible unless the same is specifically included in our Purchase/ Sub Contract.

SUPPLIER'S QUALITY ASSURANCE

1. All the materials, Component supplied must critically meet RSB Quality standards required as per samples, drawings, specifications or any other related instructions. The supplier shall allow, RSB's employee and authorized representatives for the purpose of inspecting manufacturing and inspection facilities, inspection of raw materials, WIP, FG, machines tools, fixtures jigs or any other items in connection with the manufacture of components for the company.

SAMPLE APPROVAL

1. No supplies should be made prior to the approval of sample unless specifically asked by us. It shall be the responsibility of the Supplier to submit samples well in time to be able to adhere strictly to the delivery schedule.

REJECTIONS

1. The decisions of the company on rejection shall be final and binding on the Supplier and this time clause shall be deemed to constitute an agreement to the contrary under the Sale of Goods Act. The company shall be entitled to reject the materials at any stage, cancel the contract and buy its requirements in the open market against the supplies. There is no rejection allowed unless specifically mentioned in the P.O. clearly.
2. It will be the liability of the Supplier to remove the rejected material within 15 days from our premises at his cost. In case rejection is not taken back within 15 days RSB is not liable to return back the rejection & no compensation will be given. In case of any rework done the components supplied by the suppliers, rework charges, handling charges, disposal charges & any other related charges as applicable will be recovered from Supplier's bill.
3. Rejection must be replaced within the delivery schedule and will be invoiced separately and not as replacement. All charges inclusive of freight and handling on replacements shall be borne by the Supplier.

WARRANTY

1. All the material supplied, should be free from any manufacturing, process defects & should be as per the drawings, Specifications. Any failure at RSB's customer end due to any deviation on quality, supplier shall be responsible for all damages, claims, recovery directly or indirectly claimed to RSB by any agency. Supplier shall reimburse all such expenses to RSB immediately without any delay on any ground. It will be the responsibility of the supplier to provide free replacement of component & assemblies which fail in the field because of material or manufacturing defects during the Warranty period or during the product life cycle, any offered by the company to its customers.

IN THE CASE OF SUB CONTRACT

1. Material Account to be submitted every month with regards to the Receipts & Supply in the prescribed format.
2. The supplier is responsible for safe custody of Company's material including the RAW Material/ Semi Finished/Finished/Tooling.
3. Periodic Physical Verification will be carried out by company's representative. During which supplier should assist in such verification.
4. The supplier has to obtain in writing the quantum to be consumed for each item supplied to him.
5. Supplier is fully responsible for quantity lifted by him till the entire quantity is supplied by him as per specification.
6. The supplier should also return the resultant scrap generated during machining. The remaining material/semi finished/finished held by supplier shall be property of company & company reserves the right to seek for return of raw material in which event the supplier shall return the same forth with.
7. No process rejection is allowed unless specified in PO specifically. In case process rejection, rejected component should be returned back to RSB on a separate delivery challan. All such components should be marked with red paint & to be supplied in a separate batch to avoid mix up. Process rejection exceeding allowed rejection % full cost of raw material shall be recovered. Line rejection at RSB is not considered in the allowed process rejection (if any). Line rejection will be recovered at full cost & rejected components will not be returned back or no scrap benefit will be passed on to supplier.
8. Supplier should ensure coverage of insurance of RSB property on their premises at their own cost.

Checked By

Authorized By

For all queries related to this order contact
www.rsbglobal.com

CORPORATE OFFICE: Ubale Nagar, Nagar Road, Wagoli, Pune, 412207, Tel : 91 20 30642100 Fax : 91 20 30642101

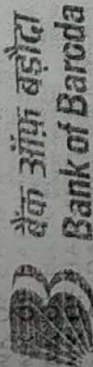

बैंक ऑफ बड़ोदा
Bank of Baroda

नाया पल्ली, मोकनेश्र-०५१०१३
NAYAPALLI, BHUBANESWAR-751013
RTGS / NEFT IFSC CODE: BARB0SAVNAY केश क्रेडिट खाता / CASH CREDIT ACCOUNT

जारी की गई तारीख से तीन माह के लिए वैध / VALID FOR THREE MONTHS FROM THE DATE OF ISSUE

CBS 01112018
D D M M Y Y Y Y

Or Bearer

या धारक को

GRAMTARANG EMPLOYABILITY TRNG SERV P LTD

Pay FORTY EIGHT THOUSAND TWO HUNDRED THIRTY THREE AND

Rupees रुपये

PAISE FORTY FIVE ONLY

₹

***48,233.45

अदा करें

A/C Payee

FOR RSB TRANSMISSIONS I LTD

खा. सं.
A/c No. 27650500000075

NOT OVER Rupees 48,234/-

BOB

भारत की सभी शाखाओं में समतुल्यपर देय
Payable at par at all branches in India

CC/2012/SE

⑈003438⑈ 751012004⑈ 500075⑈ 30

Please sign above

[Handwritten Signature]

Received
for
CTIS
[Handwritten Signature]

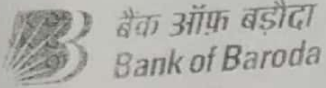

बैंक ऑफ़ बड़ोदा
Bank of Baroda

नाया पल्ली, भोबनेश्र-७५१०१३
NAYAPALLI, BHUBANESWAR-751013
RTGS / NEFT IFSC CODE: BARB0SAVNAY कॅश क्रेडिट खाता / CASH CREDIT ACCOUNT

जारी की गई तारीख से तीन माह के लिए वैध / VALID FOR THREE MONTHS FROM THE DATE OF ISSUE

CBS 2 5 0 1 2 0 1 9
D D M M Y Y Y Y

Or Bearer

Pay GRAMTARAING EMPLOYABILITY TRNG SERV P LTD

या धारक को

Rupees रूपये SIXTY SEVEN THOUSAND ONE HUNDRED FORTY THREE AND PAISE

₹ ***67,143.36

अदा करें

THIRTY SIX ONLY

FOR RSB TRANSMISSIONS I LTD

खा. सं. 27650500000075
A/c No.

A/c Payee

NOT OVER Rs. 67,144/-

Please sign above

CC/2012/SE

भारत की सभी शाखाओं में सममूल्यपर देय BOB
Payable at par at all branches in India

⑈003680⑈ 751012004⑈ 500075⑈ 30

15/08/2018 159679
SESHAASA (K) / CTS - 2010

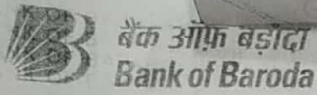

बैंक ऑफ़ बड़ोदा
Bank of Baroda

नाया पल्ली, भोवनेश्वर-751013

NAYAPALLI, BHUBANESWAR-751013

RTGS / NEFT IFSC CODE: BARB0SAVNAY कॅश क्रेडिट खाता / CASH CREDIT ACCOUNT

CBS

VALID FOR THREE MONTHS FROM THE DATE OF ISSUE
0 5 1 2 2 0 1 8
D D M M Y Y Y Y

Pay GRAMTARANG EMPLOYABILITY TRNG SERV P LTD

Or Bearer

Rupees रुपये TWENTY SEVEN THOUSAND THREE HUNDRED SEVEN AND PAISE ONE

या धारक को

ONLY

अदा करें

₹

***27,307.01

खा. सं.
A/c No.

27650500000075

A/c Payee

FOR RSB TRANSMISSIONS I LTD

NOT OVER Rs. 27,308/-

CC/2012/SE

भारत की सभी शाखाओं में सममूल्यपर देय
Payable at par at all branches in India

BOB

D.H.H. Sharma

Please sign above

⑈003498⑈ 751012004⑈ 500075⑈ 30

जारी करने की तिथि से 3 माह के लिए ही VALID FOR 3 MONTHS FROM THE DATE OF ISSUE

08012019
D D M M Y Y Y Y

बैंक ऑफ इंडिया
Bank of India
VSS NAGAR Branch, VSS NAGAR ORISSA - 751007
IFSC : BKID0005160

PayGram Training Employability Training Services Pvt. Ltd.
या धारक को Or Bearer

रुपये Rupees Six thousand Six hundred thirty Eight only.
₹ 6638/-

चेक नम्बर की प्रतिलिपि (कॉपी) Cheque number's ADHAR number (optional)

खा. सं. A/C No. 516020110000115

MECATECH INDIA

For MECATECH INDIA

Signature of Proprietor
Please sign as Proprietor

हमारी सभी शाखाओं पर समारोपण में देा PAYABLE AT ALL OUR BRANCHES IN CLEARING

॥009190॥ 751013031: 000808॥

SESHAASA (K) / CTS-2010 01150189

जारी करने की तिथि से 3 माह के लिए ही VALID FOR 3 MONTHS FROM THE DATE OF ISSUE

08012019
D D M M Y Y Y Y

बैंक ऑफ इंडिया
Bank of India
VSS NAGAR Branch, VSS NAGAR ORISSA - 751007
IFSC : BKID0005160

Pay Gram Training Employability Training Services Pvt. Ltd.
या धारक को Or Bearer

रुपये Rupees Nine thousand one hundred twenty five only.
₹ 9125/-

चेक नम्बर की प्रतिलिपि (कॉपी) Cheque number's ADHAR number (optional)

खा. सं. A/C No. 516020110000115

MECATECH INDIA

For MECATECH INDIA

Signature of Proprietor
Please sign as Proprietor

हमारी सभी शाखाओं पर समारोपण में देा PAYABLE AT ALL OUR BRANCHES IN CLEARING

॥009189॥ 751013031: 000808॥

SESHAASA (K) / CTS-2010 01150189



Subrat Kumar Swain <subratkumar.swain@gramtarang.org.in>

GATE MARK

3 messages

K.K STEELS <kksteelsic@rediffmail.com>
To: subratkumar.swain@gramtarang.org.in

Wed, Sep 19, 2018 at 10:20 AM

Dear Sir,
Please find attached the gate position highlight.

Thanks & Regards

M/s K. K. STEELS
Mfg. of : Investment Casting
(Ferrous & Non Ferrous)
An ISO 9001:2008 Certified Company,
Office :- At/Po- Ambica Sahi, Ward No -01,
Ps- Baripada, Dist-Mayurbhanj, 757001 (ODISHA)
Mob :- 094370-33624, 094371-61645,
E-mail : kksteelsic@rediffmail.com.
Web: www.kksteelsic.in

 **KKS-47__48.pdf**
535K

Subrat Kumar Swain <subratkumar.swain@gramtarang.org.in>
To: kksteelsic@rediffmail.com

Sun, Sep 23, 2018 at 6:57 AM

Dear Sir,
Please find the modified gate location and confirm me the same for further processing.

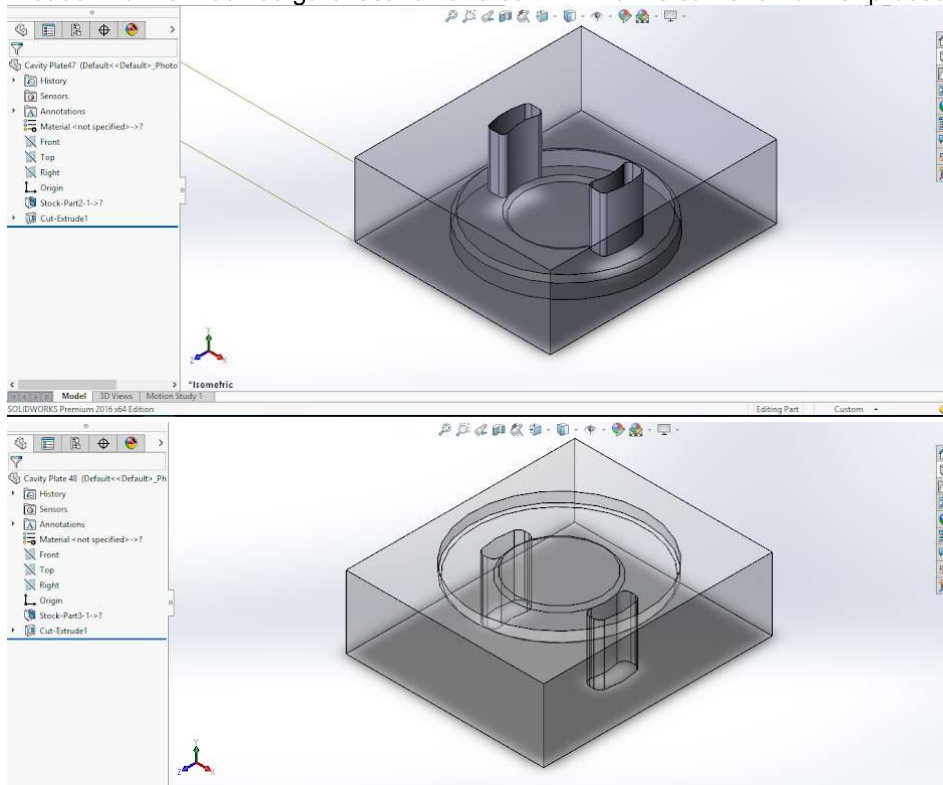

Thanks & Regards

Subrat Kumar Swain

Assistant Manager, CNC Production

Cell:+91-7440019928

+91-8895799659

+91-7008321742

[Quoted text hidden]

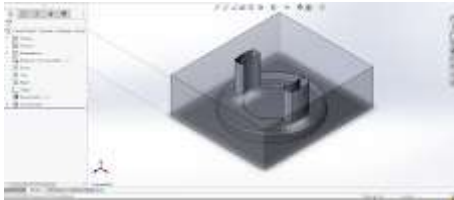
2 attachments**Cavity plate 47.PNG**

229K

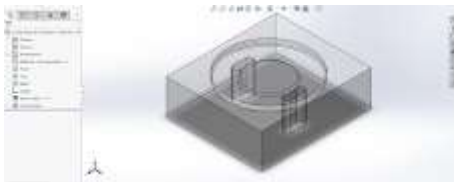
**Cavity plate48.PNG**

222K

K.K STEELS <kksteelsic@rediffmail.com>
To: Subrat Kumar Swain <subratkumar.swain@gramtarang.org.in>

Tue, Sep 25, 2018 at 11:19 AM

Dear Sir,

With due regards, we are conforming the gate location herewith and kindly process the die.

Thanks & Regards

M/s K. K. STEELS
Mfg. of : Investment Casting
(Ferrous & Non Ferrous)
An ISO 9001:2008 Certified Company,
Office :- At/Po- Ambica Sahi, Ward No -01,
Ps- Baripada, Dist-Mayurbhanj, 757001 (ODISHA)
Mob :- 094370-33624, 094371-61645,
E-mail : kksteelsic@rediffmail.com.
Web: www.kksteelsic.in

[Quoted text hidden]





Journal Voucher

No. : JV/11/28(A)

Dated : 17-Nov-2017

Particulars		Amount
Collective for Integrated Livelihood Initiatives	Dr 1,00,000.00	
To Grant in Aid (CINI) CINI Project	1,00,000.00 Cr	1,00,000.00
On Account of : Being bill raised towards professional services for the project titled Detailed Livelihood plan of the families for second phase work at Odisha		
		Rs. 1,00,000.00
		Rs. 1,00,000.00

Authorised Signatory



Journal Voucher

No. : JV/03/158

Dated : 31-Mar-2018

Particulars		Amount
Collective for Integrated Livelihood Initiatives	Dr 1,80,000.00	
TDS Receivable (CINI)	Dr 20,000.00	
To Grant in Aid (CINI)		2,00,000.00
CINI Project	2,00,000.00 Cr	
Rs. 2,00,000.00		Rs. 2,00,000.00

On Account of :

Being bill raised towards professional services for the project titled Detailed Livelihood plan of the families for second phase work at Odisha submission of draft report

Authorised Signatory



Prof. Haribandhu Panda, Ph.D.
Vice Chancellor
Centurion University of Technology and Management
Paralakhemundi, Odisha
Mob: +91 – 9861320399, 9337388801

December 29, 2017

Email: <http://www.cutm.ac.in>

Dear Sir,

This is with reference to the ongoing contract with CINI dated September 19, 2017 which will end on 30st December 2017.

We would like to take this opportunity to extend the contract till February 7, 2018. This is due to time required to close the final report. All other terms will remain as per the earlier contract.

Hence, the professional fees for the contract duration would be same i.e. Rs 3,00,000 (Rupees Three Lakh only). CINI will not provide any infrastructural, office, communication, secretarial or other support to you. CINI would provide you with all the necessary materials.

With regards

Yours Sincerely,

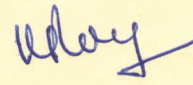
for 

Ganesh Neelam
Executive Director



Receipt Voucher

No. : BR/06/

Dated : 14-Jun-2017

Particulars	Amount
Account : Swabhiman NGO	40,000.00
Through : OBC-04951131001953 (Sahid Nagar)	
On Account of : Being amount received from Swabhiman.	
Amount (in words) : INR Forty Thousand Only	
	Rs. 40,000.00

Authorised Signatory



CENTURION UNIVERSITY OF TECHNOLOGY & MANAGEMENT

At-Ramachandrapur, P.O.-Jatni,
Dist.-Khordha - 752050 (ODISHA)
www.cutm.ac.in
Ph. No. : (0674) 2492186, 2492495
Fax : (0674) 2490480

D/BLR/No..

4

RECEIPT

Date : 02/6/2017

Full Name : SWABHIMAN .	Phone No. :
Address : Kalpana chakra, Near Sambalpur University Bhubaneswar, Odisha	Mobile No. : 8984537877
	Email : (Acct#)
	Tax Exemption Required Yes No
	Please provide PAN No.

Currency : INR USD EUR Other Currency

(Please Specify)

Amount : forty thousand only in words : (forty thousand only)
Rs 40000/-

Nationality : Indian Others (Please specify)

By Cheque No. */DD No./Reference No. : 739175 dtd. 2/6/17.

Bank Name & Branch : SBI, Rajpath, Bhubaneswar W. Date : 02/6/17

To Support

Settlement for impact Analysis Study of Project
led by School Management led by SWABHIMAN

Type of Donor : Individual Corporate PSU HUG Trust/Foundation

Sole-Proprietorship Others (Please Specify)

* Cheques are subject to realization

Received Through

Donor Signature

PAN - AAAJC0752B
G-21/2011-12/ Dt. 04.08.2011
12AA-15/2011-12/ Dt. 04.08.2011



mean that teachers will have to enhance their range of teaching styles
schools to respond to these challenges will not only depend on school leadership, but
academic and supplementary support provided by the State Government and local

State Bank Of India

(07188)-RAJPATH(BHUBANESWAR)
75, BUDHANAGAR,
BHUBANESWAR, ORISSA 751006
Tel : 764 2311390 Fax : IFS Code : SBIN0007188 SWIFT :

VALID FOR 3 MONTHS ONLY
02062017

Centurion University of Technology & Management
ES Forty thousand only.

अदा करें ₹ 40000/-

1642583208

VALID UPTO ₹ 10 LACS AT NON-HOME BRANCH

SB ACCOUNT
PREFIX :
1515700023

Mohit K. Mahapatra
Treasurer
Swabhiman

Pratik Mahapatra
General Secretary
Swabhiman

CHEQUE Payable at Par at All Branches of SBI

⑈ 739175⑈ 751002015⑈ 004461⑈ 31

Centurion University (Jatni)-2015-16

Ramachandrapur, Jatni, Khurda

Odisha

E-Mail : cfo@cutm.ac.in

Journal VoucherNo. : **JV/01/88**

Dated : 31-Jan-2016

Particulars	Debit	Credit
DST Project Receivable <i>Dr</i>	71,000.00	
<i>To</i> Grant-in-Aid (DST) DST Project 71,000.00 <i>Cr</i>		71,000.00
	₹ 71,000.00	₹ 71,000.00

On Account of :being the grant from DST
Project receivable against
the expenses

Authorised Signatory



CENTURION UNIVERSITY OF TECHNOLOGY & MANAGEMENT

D/BLR/No. 16

At-Ramachandrapur, P.O.-Jatni,
Dist.-Khordha - 752050 (ODISHA)
www.cutm.ac.in
Ph. No. : (0674) 2492186, 2492495
Fax : (0674) 2490480

RECEIPT

Date: 27/8/12

Full Name: EDITI (DST-NIMAD)	Phone No.:
Address: Project - 2018-19. Ahmedabad.	Mobile No.:
	Email:
	Tax Exemption Required Yes No
	Please provide PAN No.

Currency: INR USD EUR Other Currency

(Please Specify) TO Conduct EAC (5)

Amount: ₹ 80000/- In words: Eighty thousand/-

Nationality: Indian Others (Please specify)

By Cheque No. */DD No./Reference No.: Ad to OBC-1953 on 27/8/12

Bank Name & Branch: OBC - Ahmedabad

Date:

To Support TO Conduct EAC (5)

Type of Donor: Individual Corporate PSU HUG Trust/Foundation

Sole-Proprietorship Others (Please Specify)

* Cheques are subject to realization

Received Through Bank - 1953 (OBC)

Donor Signature

PAN - AAAJC0752B
80G-21/2011-12/ Dt. 04.08.2011
12AA-15/2011-12/ Dt. 04.08.2011





ENTREPRENEURSHIP DEVELOPMENT INSTITUTE OF INDIA

Near Village Bhat, Via Ahmedabad Airport & Indira Bridge, P.O. Bhat - 382 428, Dist. : Gandhinagar, Gujarat, India.

Tel. : +91-79-23969153, 23969158, 23969159, 23969161

E-mail : info@ediindia.org

Telefax : +91-79-23969164

Website : www.ediindia.org

S. B. Sareen

Sr. Faculty & Project Director: DST-NIMAT

EDII/DST-NIMAT/18-19/017

Date: 03/07/2018

SPEED POST

Prof. (Dr.) Haribandhu Panda

Vice Chancellor

Centurion University of Technology and Management (CUTM)

At - Ramchandrapur, P.O. Jatni

District: Khurda

Bhubaneswar - 752 050

Odisha

Kind Attention: Prof. Umakanta Nayak, Asst. Prof., School of Management & Camp
Coordinator

Dear Sir,

Sub: DST-NIMAT Project 2018-19: Sanction Order

Greetings from EDII, Ahmedabad!

This is with reference to your proposal submitted for conducting activities / programme(s) under the aegis of National Science & Technology Entrepreneurship Development Board (NSTEDB), Department of Science and Technology, Govt. of India, New Delhi.

We are happy to inform you that the following activities / programmes have been sanctioned:

Sr. No.	Activity / Programme	No.	Amount in Rs.	Locations
1	Entrepreneurship Awareness Camp (EAC)	5	100000	As mentioned in proposal
	Total	5	100000	

You are requested to please go through the enclosed **Guidelines / Terms & Conditions** as it is **mandatory to follow the same.**

Please note that the **first installment is to be released on receipt of the following documents:**

1. Duly Signed Agreement
2. Duly Signed "Terms & Conditions" (each Page)
3. Action Plan [Annexure-I]
4. Bank Details [Annexure-IA]



The funds will be transferred through RTGS/NEFT. Please make sure that the above said documents must reach us as early as possible, but not later than **ONE MONTH** of receiving this sanction letter. Non receipt of the same may be considered as your unwillingness to take up the programme(s).

As per point no. 11 of the enclosed Terms & Conditions, it is expected to generate results in terms of unit establishment from programmes like; EDP, WEDP and TEDP. Hope, you will design the required strategy to show case desired result.

For any additional information, please contact either me (Email ID: sareen@ediindia.org, Mobile: 09925110040) or my colleague Mr. Prakash Solanki (Email ID: psolanki@ediindia.org, Mobile: 09723816384).

We look forward to have a long term professional relationship.

Thanking you, with regards,

(S. B. Sareen)

Encl.: a. a

INDIAN INCOME TAX RETURN ACKNOWLEDGEMENT

[Where the data of the Return of Income in Form ITR-1 (SAHAJ), ITR-2, ITR-3, ITR-4, ITR-5, ITR-6, ITR-7 filed and verified electronically]

Assessment Year
2019-20

PERSONAL INFORMATION AND THE ACKNOWLEDGEMENT NUMBER	Name			CENTURION SCIENCE AND TECHNOLOGY ENTERPRENEURSHIP FACILITATION CENTRE		PAN AAECC7721R	
	Flat/Door/Block No		Name Of Premises/Building/Village			Form Number.	ITR-7
	AT ALLURI NAGAR		R SITAPUR				
	Road/Street/Post Office		Area/Locality				
	VIA UPPALADA		PARLAKHEMUNDI			Status AOP/BOI	
	Town/City/District		State	Pin/ZipCode	Filed u/s		
	BEHERAMPUR		ORISSA	761211	139(1)-On or before due date		
	Assessing Officer Details (Ward/Circle)			EXEMPTION WARD, BERHAMPUR			
	e-filing Acknowledgement Number			181049111280919			
	COMPUTATION OF INCOME AND TAX THEREON	1	Gross total income			1	0
2		Total Deductions under Chapter-VI-A			2	0	
3		Total Income			3	0	
3a		Deemed Total Income under AMT/MAT			3a	0	
3b		Current Year loss, if any			3b	0	
4		Net tax payable			4	0	
5		Interest and Fee Payable			5	0	
6		Total tax, interest and Fee payable			6	0	
7		Taxes Paid	a	Advance Tax	7a	0	
			b	TDS	7b	0	
		c	TCS	7c	0		
		d	Self Assessment Tax	7d*	0		
		e	Total Taxes Paid (7a+7b+7c +7d)	7e	0		
8	Tax Payable (6-7e)			8	0		
9	Refund (7e-6)			9	0		
10	Exempt Income	Agriculture			10	0	
		Others		0			

Income Tax Return submitted electronically on **28-09-2019 12:36:13** from IP address **117.197.251.78** and verified by**DR.MUKTI KANTA MISHRA** having PAN **ADOPM0255A** on **28-09-2019 12:36:13** from IP address **117.197.251.78** using **Digital Signature Certificate (DSC)**DSC details: **16187183CN=e-Mudhra Sub CA for Class 2 Individual 2014,OU=Certifying Authority,O=eMudhra Consumer Services Limited,C=IN****DO NOT SEND THIS ACKNOWLEDGEMENT TO CPC, BENGALURU**

	referred to in section 11(2)(b)(ii) or section 11(2)(b)(iii), or	
(c)	has not been utilised for purposes for which it was accumulated or set apart during the period for which it was to be accumulated or set apart, or in the year immediately following the expiry thereof? If so, the details thereof	No

II. APPLICATION OR USE OF INCOME OR PROPERTY FOR THE BENEFIT OF PERSONS REFERRED TO IN SECTION 13(3)

1.	Whether any part of the income or property of the institution was lent, or continues to be lent, in the previous year to any person referred to in section 13(3) (hereinafter referred to in this Annexure as such person)? If so, give details of the amount, rate of interest charged and the nature of security, if any.	No
2.	Whether any part of the income or property of the institution was made, or continued to be made, available for the use of any such person during the previous year? If so, give details of the property and the amount of rent or compensation charged, if any.	No
3.	Whether any payment was made to any such person during the previous year by way of salary, allowance or otherwise? If so, give details	No
4.	Whether the services of the institution were made available to any such person during the previous year? If so, give details thereof together with remuneration or compensation received, if any	No
5.	Whether any share, security or other property was purchased by or on behalf of the institution during the previous year from any such person? If so, give details thereof together with the consideration paid	No
6.	Whether any share, security or other property was sold by or on behalf of the institution during the previous year to any such person? If so, give details thereof together with the consideration received	No
7.	Whether any income or property of the institution was diverted during the previous year in favour of any such person? If so, give details thereof together with the amount of income or value of property so diverted	No
8.	Whether the income or property of the institution was used or applied during the previous year for the benefit of any such person in any other manner? If so, give details	No

III. INVESTMENTS HELD AT ANY TIME DURING THE PREVIOUS YEAR(S) IN CONCERNS IN WHICH PERSONS REFERRED TO IN SECTION 13(3) HAVE A SUBSTANTIAL INTEREST

S. No	Name and address of the concern	Where the concern is a company, number and class of shares held	Nominal value of the investment(₹)	Income from the investment(₹)	Whether the amount in col. 4 exceeded 5 per cent of the capital of the concern during the previous year-say, Yes/No
Total					

Place **BHUBANESWA**

R

Date **08/10/2018**

Name
Membership Number
FRN (Firm Registration Number)
Address

BIBEKANANDA MOHANTY
056264
310009E
SRB & ASSOCIATES 5TH FL
OOR IDCO TOWER JANPAT
H, BHUBANESWAR

Form Filing Details	
Revision/Original	Original

FORM NO. 10B

[See rule 17B]

Audit report under section 12A(b) of the Income-tax Act, 1961, in the case of charitable or religious trusts or institutions

We have examined the balance sheet of CENTURION SCIENCE AND TECHNOLOGY ENTERPRENEURSHIP FACILITATION CENTRE ,AT-ALLURI NAGAR,R SITAPUR,UPPALADA PARALAKHEMUNDI , AAECC7721R [name and PAN of the trust or institution] as at 31/03/2019 and the Profit and loss account for the year ended on that date which are in agreement with the books of account maintained by the said trust or institution.

We have obtained all the information and explanations which to the best of our knowledge and belief were necessary for the purposes of the audit. In our opinion, proper books of account have been kept by the head office and the branches of the abovenamed institution visited by us so far as appears from our examination of the books, and proper Returns adequate for the purposes of audit have been received from branches not visited by us , subject to the comments given below:

NIL

In our opinion and to the best of our information, and according to information given to us , the said accounts give a true and fair view-

(i) in the case of the balance sheet, of the state of affairs of the above named institution as at 31/03/2019 and

(ii) in the case of the profit and loss account, of the profit or loss of its accounting year ending on 31/03/2019

The prescribed particulars are annexed hereto.

Place BHUBANESWADate 08/10/2018

Name BIBEKANANDA MOHANTY
 Membership Number 056264
 FRN (Firm Registration Number) 310009E
 Address SRB & ASSOCIATES 5TH FL
OOR IDCO TOWER JANPAT
H, BHUBANESWAR

ANNEXURE

Statement of particulars

I. APPLICATION OF INCOME FOR CHARITABLE OR RELIGIOUS PURPOSES

1.	Amount of income of the previous year applied to charitable or religious purposes in India during that year (₹)	20235129
2.	Whether the <u>institution</u> has exercised the option under clause (2) of the Explanation to section 11(1) ? If so, the details of the amount of income deemed to have been applied to charitable or religious purposes in India during the previous year (₹)	No
3.	Amount of income accumulated or set apart for application to charitable or religious purposes, to the extent it does not exceed 15 per cent of the income derived from property held under trust wholly for such purposes. (₹)	No.
4.	Amount of income eligible for exemption under section 11(1)(c) (Give details)	No
5.	Amount of income, in addition to the amount referred to in item 3 above, accumulated or set apart for specified purposes under section 11(2) (₹)	0
6.	Whether the amount of income mentioned in item 5 above has been invested or deposited in the manner laid down in section 11(2)(b) ? If so, the details thereof.	Not Applicable
7.	Whether any part of the income in respect of which an option was exercised under clause (2) of the Explanation to section 11(1) in any earlier year is deemed to be income of the previous year under section 11(1B) ? If so, the details thereof (₹)	No
8.	Whether, during the previous year, any part of income accumulated or set apart for specified purposes under section 11(2) in any earlier year-	
(a)	has been applied for purposes other than charitable or religious purposes or has ceased to be accumulated or set apart for application thereto, or	No
(b)	has ceased to remain invested in any security referred to in section 11(2)(b)(i) or deposited in any account	No



e-Filing *Anywhere Anytime*
Income Tax Department, Government of India

ACKNOWLEDGEMENT OF RECEIPT OF FORM (Other Than ITR)

Name	CENTURION SCIENCE AND TECHNOLOGY ENTERPRENEURSHIP FACILITATION CENTRE	PAN	AAECC7721R
Form No	10B	Assessment Year	2019-20
e-Filing Acknowledgement Number	181043301280919	Date of e-Filing	28/09/2019

*For and on behalf of,
e-Filing Administrator*

(This is a computer generated Acknowledgment Receipt and needs no signature)

[Click to Print the Receipt](#)

[Click here to Close the window](#)



SRB & Associates
CHARTERED ACCOUNTANTS

5TH FLOOR, IDCO TOWER, JANAPATH,
BHUBANESWAR - 751 022, ODISHA
TEL : 0674 - 2541043, 2545880
FAX : 91- 674 - 2546414
Email: srbbsr@rediffmail.com

JAJPUR ROAD - 06726-220345
NEW DELHI - 011-51601983
KOLKATA - 033-30930975
SECUNDERABAD - 040-27510739

Independent Auditor's Report

To the Members of CENTURION SCIENCE AND TECHNOLOGY ENTREPRENEURSHIP FACILITATION CENTRE

Report on the Standalone Financial Statements

Opinion

We have audited the standalone financial statements of **CENTURION SCIENCE AND TECHNOLOGY ENTREPRENEURSHIP FACILITATION CENTRE**. ("The Company"), which comprise of the Balance Sheet as at 31st March 2019, and the statement of Income & Expenditure for the period ended on that date, and notes to the financial statements, including a summary of significant accounting policies and other explanatory information.

In our opinion and to the best of our information and according to the explanations given to us, the aforesaid standalone financial statements give the information required by the Companies Act, 2013 in the manner so required and give a true and fair view in conformity with the accounting principles generally accepted in India, of the state of affairs of the Company as at March 31, 2019, its excess of expenditure over income for the period ended on that date.

Basis for Opinion

We conducted our audit in accordance with the Standards on Auditing (SAs) specified under section 143(10) of the Companies Act, 2013. Our responsibilities under those Standards are further described in the *Auditor's Responsibilities for the Audit of the Financial Statements* section of our report. We are independent of the Company in accordance with the *Code of Ethics* issued by the Institute of Chartered Accountants of India together with the ethical requirements that are relevant to our audit of the financial statements under the provisions of the Companies Act, 2013 and the Rules there under, and we have fulfilled our other ethical responsibilities in accordance with these requirements and the *Code of Ethics*. We believe that the audit evidence we have obtained is sufficient and appropriate to provide a basis for our opinion.





Information Other than the Standalone Financial Statements and Auditor's Report Thereon

The Company's Board of Directors is responsible for the preparation of the other information. The other information comprises the information included in the Management Discussion and Analysis, Board's Report including Annexure to Board's Report, Business Responsibility Report, Corporate Governance and Shareholder's Information, but does not include the standalone financial statements and our auditor's report thereon.

Our opinion on the standalone financial statements does not cover the other information and we do not express any form of assurance conclusion thereon.

In connection with our audit of the standalone financial statements, our responsibility is to read the other information and, in doing so, consider whether the other information is materially inconsistent with the standalone financial statements or our knowledge obtained during the course of our audit or otherwise appears to be materially misstated.

If, based on the work we have performed, we conclude that there is a material misstatement of this other information; we are required to report that fact. We have nothing to report in this regard.

Responsibilities of Management and Those Charged with Governance for the Standalone Financial Statements

The Company's Board of Directors is responsible for the matters stated in section 134(5) of the Companies Act, 2013 ("the Act") with respect to the preparation of these standalone financial statements that give a true and fair view of the financial position, financial performance, (changes in equity) and cash flows of the Company in accordance with the accounting principles generally accepted in India, including the accounting Standards specified under section 133 of the Act. This responsibility also includes maintenance of adequate accounting records in accordance with the provisions of the Act for safeguarding of the assets of the Company and for preventing and detecting frauds and other irregularities; selection and application of appropriate accounting policies; making judgments and estimates that are reasonable and prudent; and design, implementation and maintenance of adequate internal financial controls, that were operating effectively for ensuring the accuracy and completeness of the accounting records, relevant to the preparation and presentation of the financial statements that give





SRB & Associates

CHARTERED ACCOUNTANTS

a true and fair view and are free from material misstatement, whether due to fraud or error.

In preparing the financial statements, the Board of Directors is responsible for assessing the Company's ability to continue as a going concern, disclosing, as applicable, matters related to going concern and using the going concern basis of accounting unless the Board of Directors either intends to liquidate the Company or to cease operations, or has no realistic alternative but to do so.

Those Board of Directors are also responsible for overseeing the company's financial reporting process.

Auditor's Responsibilities for the Audit of the Financial Statements

Our objectives are to obtain reasonable assurance about whether the financial statements as a whole are free from material misstatement, whether due to fraud or error, and to issue an auditor's report that includes our opinion. Reasonable assurance is a high level of assurance, but is not a guarantee that an audit conducted in accordance with SAs will always detect a material misstatement when it exists. Misstatements can arise from fraud or error and are considered material if, individually or in the aggregate, they could reasonably be expected to influence the economic decisions of users taken on the basis of these financial statements.

Report on Other Legal and Regulatory Requirements

1. As required by the Companies (Auditor's Report) Order, 2016 ("the Order"), issued by the Central Government of India in terms of sub-section (11) of section 143 of the Companies Act, 2013, is not applicable .

2. As required by Section 143(3) of the Act, we report that:

a) We have sought and obtained all the information and explanations which to the best of our knowledge and belief were necessary for the purposes of our audit.

(b) In our opinion, proper books of account as required by law have been kept by the Company so far as it appears from our examination of those books.





(c) The Balance Sheet and the Statement of income and Expenditure dealt with by this Report are in agreement with the relevant books of account.

(d) In our opinion, the aforesaid standalone financial statements comply with the Accounting Standards specified under Section 133 of the Act, read with Rule 7 of the Companies (Accounts) Rules, 2014.

(e) On the basis of the written representations received from the directors as on 31st March, 2019 taken on record by the Board of Directors, none of the directors is disqualified as on 31st March, 2019 from being appointed as a director in terms of Section 164(2) of the Act.

(f) With respect to the adequacy of the internal financial controls over financial reporting of the Company and the operating effectiveness of such controls, refer to our separate report in "Annexure-A" and

(g) With respect to the other matters to be included in the Auditor's Report in accordance with Rule 11 of the Companies (Audit and Auditors) Rules, 2014, in our opinion and to the best of our information and according to the explanations given to us:

i. The Company has disclosed the impact of pending litigations on its financial position in its financial statements.

ii. The Company did not have any long-term contracts including derivative contracts for which there were any material foreseeable losses.

iii. There are no amounts which are required to be transferred to the Investor Education and Protection Fund by the Company.

For SRB & Associates
Chartered Accountants
Firm Regn. No: 310009E

K.P Swain

K.P Swain
Partner
M.N-306323

Bhubaneswar
7th September 2019

UDIN: 19306323AAAA3M6848





Annexure "A" to the Independent Auditor's report of even date on the Standalone Financial Statements as at and for the year ended 31st March 2019 of CENTURION SCIENCE AND TECHNOLOGY ENTREPRENEURSHIP FACILITATION CENTRE

Report on the Internal Financial Controls under Clause (i) of Sub-section 3 of Section 143 of the Companies Act, 2013 ("the Act")

We have audited the internal financial controls over financial reporting of **CENTURION SCIENCE AND TECHNOLOGY ENTREPRENEURSHIP FACILITATION CENTRE** ("the Company") as of 31st March, 2019 in conjunction with our audit of the standalone financial statements of the Company for the year ended on that date.

Management's Responsibility for Internal Financial Controls

The Company's management is responsible for establishing and maintaining internal financial controls based on the internal control over financial reporting criteria established by the Company considering the essential components of internal control stated in the Guidance Note on Audit of Internal Financial Controls over Financial Reporting issued by the Institute of Chartered Accountants of India. These responsibilities include the design, implementation and maintenance of adequate internal financial controls that were operating effectively for ensuring the orderly and efficient conduct of its business, including adherence to company's policies, the safeguarding of its assets, the prevention and detection of frauds and errors, the accuracy and completeness of the accounting records, and the timely preparation of reliable financial information, as required under the Companies Act, 2013.

Auditors' Responsibility

Our responsibility is to express an opinion on the Company's internal financial controls over financial reporting based on our audit. We conducted our audit in accordance with the Guidance Note on Audit of Internal Financial Controls Over Financial Reporting (the "Guidance Note") and the Standards on Auditing, issued by ICAI and deemed to be prescribed under section 143(10) of the Companies Act, 2013, to the extent applicable to an audit of internal financial controls, both applicable to an audit of Internal Financial Controls and, both issued by the Institute of Chartered Accountants of India. Those Standards and the Guidance Note require that we comply with ethical requirements and plan and perform the audit to obtain reasonable assurance about whether adequate internal financial controls over financial reporting was established and maintained and if such controls operated effectively in all material respects.





Our audit involves performing procedures to obtain audit evidence about the adequacy of the internal financial controls system over financial reporting and their operating effectiveness. Our audit of internal financial controls over financial reporting included obtaining an understanding of internal financial controls over financial reporting, assessing the risk that a material weakness exists, and testing and evaluating the design and operating effectiveness of internal control based on the assessed risk. The procedures selected depend on the auditor's judgment, including the assessment of the risks of material misstatement of the standalone financial statements, whether due to fraud or error.

We believe that the audit evidence we have obtained is sufficient and appropriate to provide a basis for our audit opinion on the Company's internal financial controls system over financial reporting.

Meaning of Internal Financial Controls Over Financial Reporting

A company's internal financial control over financial reporting is a process designed to provide reasonable assurance regarding the reliability of financial reporting and the preparation of standalone financial statements for external purposes in accordance with generally accepted accounting principles. A company's internal financial control over financial reporting includes those policies and procedures that (1) pertain to the maintenance of records that, in reasonable detail, accurately and fairly reflect the transactions and dispositions of the assets of the company; (2) provide reasonable assurance that transactions are recorded as necessary to permit preparation of financial statements in accordance with generally accepted accounting principles, and that receipts and expenditures of the company are being made only in accordance with authorisations of management and directors of the company; and (3) provide reasonable assurance regarding prevention or timely detection of unauthorised acquisition, use, or disposition of the company's assets that could have a material effect on the standalone financial statements.

Inherent Limitations of Internal Financial Controls over Financial Reporting

Because of the inherent limitations of internal financial controls over financial reporting, including the possibility of collusion or improper management override of controls, material misstatements due to error or fraud may occur and not be detected. Also, projections of any evaluation of the internal financial controls over financial reporting to future periods are subject to the risk that the internal financial control over financial reporting may become inadequate because of changes in conditions, or that the degree of compliance with the policies or procedures may deteriorate.





SRB & Associates

CHARTERED ACCOUNTANTS
Opinion

In our opinion, the Company has, in all material respects, an adequate internal financial controls system over financial reporting and such internal financial controls over financial reporting were operating effectively as at 31st March, 2019, based on the internal control over financial reporting criteria established by the Company considering the essential components of internal control stated in the Guidance Note on Audit of Internal Financial Controls Over Financial Reporting issued by the Institute of Chartered Accountants of India.

**For SRB & Associates
Chartered Accountants
Firm Regn. No: 310009E**

K.P Swain

**K.P Swain
Partner
M.N-306323**

**Bhubaneswar
7th September 2019**



CENTURION SCIENCE AND TECHNOLOGY ENTREPRENEURSHIP FACILITATION CENTRE
At-Alluri Nagar,PO-R.Sitapur,Uppalada,Parlakhemundi,Gajapati,Odisha
Incorporated under section 8 of Companies Act,2013
A company limited by share
Balance Sheet as at 31st March 2019

SL NO	PARTICULARS	NOTES	AS AT 31 MARCH 2019 (₹)	AS AT 31 MARCH 2018 (₹)
I	EQUITY AND LIABILITIES			
1	Shareholders' funds			
	(a) Share capital	2	1,000,000.00	1,000,000.00
	(b) Reserves and surplus	3	797,304.47	7,224,159.36
2	Non-current liabilities			
	(a) Long-term borrowings			
	(b) Other long-term liabilities			
3	Current liabilities			
	(a) Short Term Borrowing	4	5,084,556.00	5,015,630.00
	(b) Trade Payable		817,556.00	478,849.00
	(c) Other current liabilities	5	522,074.00	659,467.00
	Total		8,221,490.47	14,378,105.36
II	ASSETS			
1	Non-current assets			
	(a) Fixed assets	6		
	(i) Tangible assets		7,588,876.96	8,255,749.50
	(ii) Intangible asset		84,229.00	69,830.00
	(iii) Capital work in progress		-	-
	(b) Long-term loans and advances			
	(c) Other non-current assets	7	-	-
2	Current assets			
	(a) Cash and cash equivalents	8	161,071.51	5,334,194.86
	(b) Trade receivables		255,678.00	262,934.00
	(b) Short-term loans and advances		2,435.00	38,050.00
	(c) Other current assets	9	129,200.00	417,347.00
	Total		8,221,490.47	14,378,105.36

Accompanying Notes forming part of the financial statements

1

For SRB & Associates
Chartered Accountants
F.Regd. No.310009E

K.P Swain

K.P SWAIN
Partner
M. No.306323



Bhubaneswar
7th September 2019

**For Centurion Science and Technology
Entrepreneurship Facilitation Centre**

M.K. Mishra

Dr. M.K. Mishra
Director

D.N. Rao

Prof. D.N. Rao
Director

CENTURION SCIENCE AND TECHNOLOGY ENTREPRENEURSHIP FACILITATION CENTRE
At-Alluri Nagar, PO-R.Sitapur, Uppalada, Parlakhemundi, Gajapati, Odisha
 Incorporated under section 8 of Companies Act, 2013
 A company limited by share
Statement of Income and Expenditure as at 31st march 2019

SL NO	PARTICULARS	NOTES	FOR THE YEAR ENDED MARCH 31, 2019 (₹)	FOR THE YEAR ENDED MARCH 31, 2018 (₹)
I)	INCOME			
	Revenue from operations	10	19,881,735.24	40,693,166.37
	Other income	11	353,394.00	975,102.00
	TOTAL INCOME		20,235,129.24	41,668,268.37
II)	EXPENDITURE			
	Employee benefits expenses	12	2,980,180.00	2,640,246.00
	Training Expenses	13	20,807,944.00	33,078,677.25
	Depreciation & Amortization expenses	6	1,502,516.46	
	Less: Transferred from Capital Grants (Matching amount of depreciation on assets acquired from capital grant)		(469,966.44)	
	Other expenses	14	1,032,550.01	259,339.70
			1,371,343.96	1,942,746.48
	TOTAL EXPENSES		26,192,017.97	37,921,009.43
III)	Surplus \ (Deficit) Before exceptional and extraordinary items and tax (I-II)		(5,956,888.73)	3,747,258.94
IV)	Exceptional items		-	-
V)	Surplus \ (Deficit) Before extraordinary items and tax (III-IV)		(5,956,888.73)	3,747,258.94
VI)	Extraordinary items		-	-
VII)	Surplus \ (Deficit) Before Tax (V-VI)		(5,956,888.73)	3,747,258.94
VIII)	TAX EXPENSES			
	(a) Current tax		-	-
IX)	Surplus \ (Deficit) for the period from continuing operations (VII-VIII)		(5,956,888.73)	3,747,258.94
X)	Surplus \ (Deficit) from discontinuing operations		-	-
XI)	Tax expense of discontinuing operations		-	-
XII)	Surplus \ (Deficit) from Discontinuing operations (after tax)		-	-
XIII)	Surplus \ (Deficit) for the period		(5,956,888.73)	3,747,258.94

Accompanying Notes forming part of the financial statements

For SRB & Associates
 Chartered Accountants
 F.Regd. No.310009E

K Swain

K.P SWAIN
 Partner
 M. No.306323

Bhubaneswar
 7th September 2019



For Centurion Science and Technology
 Entrepreneurship Facilitation Centre

M.K. Mishra

Dr. M.K. Mishra
 Director

D.N. Rao

Prof. D.N. Rao
 Director

Centurion Science & Technology Entrepreneurship Facilitation Centre

At-Alluri Nagar,Po-R.Sitapur,Uppalada,Parlakhemundi, Gajapati,Odisha-761211

Note-1

1. Corporate Information.

CENTURION SCIENCE AND TECHNOLOGY ENTREPRENEURSHIP FACILITATION CENTRE is a Non-Profit making company domiciled in India. The Company engaged in improving the quality of life of the poor or otherwise underprivileged rural and urban people, by providing a complete range of financial and non-financial services so as to facilitate their growth and development into financially sustainable entities.

2. Basis of Accounting

These financial statements are prepared in accordance with Indian Generally Accepted Accounting Principles (GAAP) under the historical cost convention on accrual basis except for certain financial instruments which are measured at fair values. GAAP comprises mandatory Accounting standards as prescribed under Section 133 of the Companies Act., 2013, read With Rule 7 of the Companies (Accounting) Rules, 2014 the provisions of the Act (to the extent Notified) .Accounting policies have been consistently applied except where a newly issued Accounting standard is initially adopted or a revision to an existing accounting standard requires a change in the accounting policy hitherto in use.

SIGNIFICANT ACCOUNTING POLICIES

1. Revenue Recognition

Revenue is recognized to the extent that it is probable that the economic benefits will flow to the Company and the revenue can be reliably measured. Any grant received is recognized as and when they are received.

2. Use of Estimates

The preparation of financial statements are in conformity with the generally accepted accounting principles which requires estimates and assumptions to be made, that affects the reported amounts of assets and liabilities on the date of financial statements and the reported amount of revenues and expenses during the reported period.



3. Tangible Fixed Assets

Fixed Assets are stated at cost, net of accumulated depreciation and accumulated impairment losses, if any. The cost comprises purchase price, borrowing costs, if capitalization criteria are met and directly attributable cost of bringing the asset to its working condition for the intended use. Any subsidy/ reimbursement/ contribution received for installation and acquisition of any fixed assets is transferred to capital grant account.

Capital work- in progress is stated at cost if any.

Subsequent expenditure related to an item of fixed assets is added to its book value only if it increases the future benefits from the existing asset beyond its previously assessed standard of performance. All other expenses on existing fixed assets, including day-to-day repairs and maintenance expenditure and cost of replacing parts, are charged to the Statement of Income and Expenditure Account for the period during which such expenses are incurred.

4. Depreciation on fixed assets

Depreciation is provided on WDV Method over the period of assets after keeping 5% of cost as residual value and in the manner prescribed in the Companies Act, 2013. Depreciation on assets purchased/ acquired during the year is charged from the date of Purchase of the assets.

In respect of Addition/Deletion/Transfer of Fixed Assets depreciation is provided on proportionate basis for the period during which the assets are put to use in the company.

5. Intangible Assets

Intangible assets acquired separately are measured on initial recognition at cost. Following initial Recognition, intangible assets are carried at cost less accumulated amortization and accumulated Impairment losses, if any.

6. Capital Grant

Any amount received as capital grant/donations/contributions either from domestic source for construction of building and acquisition of assets for augmenting the objective of the company is transferred to Capital Grant Account. Matching amount of depreciation on grant asset transferred to Capital Grant Account.



NOTES FORMING PART OF ACCOUNTS

15. Provisions for taxation have not been made in accounts as the company has been registered under Section 12AA of the Income Tax Act 1961.
16. Related party Disclosure- As required by accounting Standard-18, " Related Party Disclosure"

Enterprise where there is significant influence (Where transaction Exist)

Particular of Related Party	<u>Current Year</u>	<u>Previous Year</u>
Centurion University of Technology & Management (Closing Balance)	50,84,556.00	50,15,630.00

17. Previous year figures have been re-grouped/re-arranged confirming to current year's presentation.

For SRB & Associates
Chartered Accountants
F.Regd. No.310009E

K Swain

K.P Swain
Partner
M. No.306323

Bhubaneswar
Date:-07th September 2019



**For Centurion Science and Technology
Entrepreneurship Facilitation Centre**

M.K. Mishra

Dr. M.K. Mishra
Director

D.N. Rao

Prof. D.N. Rao
Director

Notes to Financial Statement

Note No.2 : Share capital

PARTICULARS	AS AT 31 MARCH 2019		AS AT 31 MARCH 2018	
	NUMBERS		NUMBERS	
AUTHORISED				
Equity shares of ₹ 10 each	100,000	1,000,000.00	100,000	1,000,000.00
ISSUED, SUBSCRIBED & FULLY PAID UP				
Equity shares of ₹ 10 each	100,000	1,000,000.00	100,000	1,000,000.00
TOTAL	100,000	1,000,000.00	100,000	1,000,000.00

(a) Reconciliation of the number of shares and amount outstanding as at the beginning and at the end of the year.

PARTICULARS	AS AT 31 MARCH 2019		AS AT 31 MARCH 2018	
	NUMBERS		NUMBERS	
i) Shares outstanding at the beginning of the financial year.	100,000	1,000,000.00	10,000	100,000.00
ii) Bonus Shares Issued during the year	-	-	-	-
ii) Equity shares Issued during the year	-	-	90,000	900,000.00
OUTSTANDING AS AT THE END OF THE YEAR	100,000	1,000,000	100,000	1,000,000.00

(b) Details of shareholders holding more than 5% of the shares in the company

PARTICULARS	AS AT 31 MARCH 2019		AS AT 31 MARCH 2018	
	NUMBERS	% OF HOLDING	NUMBERS	% OF HOLDING
Mukti Kanta Mishra	5,000	5%	5,000	5%
Dechiraju Narasimha Rao	5,000	5%	5,000	5%
Centurion University of Technology & Management (represented by Mr Mukti Kanta Mishra)	90,000	90%	90,000	0.90
TOTAL	100,000	100%	100,000	100%

Note No.3: Reserves and surplus

PARTICULARS	AS AT MARCH 31, 2019		AS AT MARCH 31, 2018	
	(₹)		(₹)	
Reserve and Surplus consist of				
a) Capital Reserve				
Grant in aid				
Grant from BMC		5,130,942.28		5,723,018.28
Grant others		28,300.41		28,300.41
Grant from Mindtree		13,983.75		56,573.98
Less: Transferred from Capital Grants (Matching amount of depreciation on assets acquired from capital grant)		(469,966.44)		(634,666.52)
TOTAL		4,703,260.00		5,173,226.15
b) Surplus/ (Deficit)				
Excess of expenditure over income				
Opening balance		2,050,933.21		(1,696,325.74)
Surplus(Deficit) for the year		(5,956,888.73)		3,747,258.94
TOTAL		(3,905,955.53)		2,050,933.21
SUB TOTAL		797,304.47		7,224,159.36

Note No.4: Short Term Borrowings

PARTICULARS	AS AT MARCH 31, 2019		AS AT MARCH 31, 2018	
	(₹)		(₹)	
Interest Free borrowings (Unsecured)		5,084,556.00		5,015,630.00
TOTAL		5,084,556.00		5,015,630.00

Note No.5: Other current liabilities

PARTICULARS	AS AT MARCH 31, 2019		AS AT MARCH 31, 2018	
	(₹)		(₹)	
Other Liabilities *		521,528.00		444,455.00
Statutory Dues Payable		546.00		215,012.00
TOTAL		522,074.00		659,467.00

* Other Liabilities includes liabilities for expenses and salary wages payable .



	AS AT MARCH 31,2019 (₹)	AS AT MARCH 31,2018 (₹)
Note 7:- Other Non Current Assets		
Preliminary Expenses	-	-
Pre-operative Expenses	-	-
TOTAL	-	-

Note No.8: Cash and Bank balance

	AS AT MARCH 31,2019 (₹)	AS AT MARCH 31,2018 (₹)
Cash and cash equivalent		
Cash-in-hand	370.00	16,586.00
Balance with banks	-	-
-In saving bank account	160,701.51	5,317,608.86
TOTAL	161,071.51	5,334,194.86

Note No.9: Other Current Asset

	AS AT MARCH 31,2019 (₹)	AS AT MARCH 31,2018 (₹)
Deposits (Asset)		
Security Deposit	100,380.00	366,380.00
TDS Receivable	28,820.00	28,820.00
Prepaid Insurance	-	22,147.00
TOTAL	129,200.00	417,347.00



Notes to Financial Statement
Note No.10: Revenue from Operation

PARTICULARS	FOR THE YEAR ENDEED MARCH 31,2019 (₹)	FOR THE YEAR ENDEED MARCH 31,2018 (₹)
Training Income	9,998,281.24	6,516,275.59
Grant & Donation	9,883,454.00	34,176,890.78
TOTAL	19,881,735.24	40,693,166.37

Note No.11: Other Income

PARTICULARS	FOR THE YEAR ENDEED MARCH 31,2019 (₹)	FOR THE YEAR ENDEED MARCH 31,2018 (₹)
Miscellaneous income	353,394.00	975,102.00
TOTAL	353,394.00	975,102.00

Note No.12:Employee benefits expenses

PARTICULARS	FOR THE YEAR ENDEED MARCH 31,2019 (₹)	FOR THE YEAR ENDEED MARCH 31,2018 (₹)
Salaries & Wages	2,980,180.00	2,640,246.00
TOTAL	2,980,180.00	2,640,246.00

Note No.13: Training Expenses

PARTICULARS	FOR THE YEAR ENDEED MARCH 31,2019 (₹)	FOR THE YEAR ENDEED MARCH 31,2018 (₹)
Training Expenses		
Training Expenses	20,807,944.00	33,078,677.25
TOTAL	20,807,944.00	33,078,677.25

Note No.14: Other expenses

PARTICULARS	FOR THE YEAR ENDEED MARCH 31,2019 (₹)	FOR THE YEAR ENDEED MARCH 31,2018 (₹)
Bank Charges	18,556.96	20,958.77
Electricity Charges	281,725.00	382,631.00
External Linkage/internet	8,984.00	71,308.00
Legal & Consultancy	48,710.00	24,200.00
Office Expenses	474,602.00	479,622.00
Printing & Stationery	59,265.00	62,929.00
Registration Charges	7,000.00	41,800.00
Rent rate & taxes	15,850.00	16,000.00
Repair & Maintenance	47,786.00	336,827.00
Communication Related Expenses	39,615.00	7,159.00
Travelling & conveyance	276,740.00	450,457.71
Audit fee	26,550.00	26,550.00
Insurance	65,960.00	22,304.00
TOTAL	1,371,343.96	1,942,746.48



CENTURION SCIENCE AND TECHNOLOGY ENTREPRENEURSHIP FACILITATION CENTRE
Notes to financial statement

NOTE : 6

S.No	PARTICULARS	GROSS BLOCK			DEPRECIATION			NET BLOCK		
		Balance as on 01.04.2018 (₹)	Additions (₹)	Sale Transfer (₹)	Balance as on 31.03.2019 (₹)	Upto 31.03.2018 (₹)	depreciation during the year (₹)	Sale Transfer (₹)	depreciation up to Mar 2019 (₹)	Closing balance (₹)
	A. TANGIBLE ASSETS									
1	Building	1,348,633.00	-	-	1,348,633.00	244,588.57	104,884.22	-	349,472.79	999,160.21
2	Computer	348,249.00	7,150.00	-	355,399.00	80,326.74	170,741.51	-	251,068.25	1,104,044.00
3	Electrical Installation	346,783.00	39,000.00	-	385,783.00	167,628.86	54,387.45	-	222,016.31	267,922.00
4	Furniture & Fixture	553,410.00	30,001.00	-	583,411.00	64,459.99	133,356.25	-	197,816.24	179,154.00
5	vehicle	95,200.00	144,088.00	-	239,288.00	81.45	30,568.51	-	30,649.96	488,950.00
6	Machine & Equipment	1,380,279.00	485,193.00	-	1,865,472.00	516,737.00	190,962.56	-	707,699.56	95,119.00
7	Office Equipment	840,467.00	103,310.00	-	943,777.00	206,444.27	320,747.85	-	527,192.12	863,542.00
	Category	4,913,021.00	808,742.00	-	5,721,763.00	1,280,266.90	1,005,648.35	-	2,285,915.25	3,435,847.75
	B. INTANGIBLE ASSETS									
	Intangible Asset	130,500.00	41,300.00	-	171,800.00	60,669.52	26,901.66	-	87,571.00	84,229.00
		5,043,521.00	850,042.00	-	5,893,563.00	1,340,936.41	1,032,550.01	-	2,373,486.25	3,520,076.75
										3,632,754.00

ASSETS ACQUIRED OUT OF CAPITAL GRANT

S.No	PARTICULARS	GROSS BLOCK			DEPRECIATION			NET BLOCK		
		Balance as on 01.04.2018 (₹)	Additions (₹)	Sale Transfer (₹)	Balance as on 31.03.2019 (₹)	Upto 31.03.2018 (₹)	depreciation during the year (₹)	Sale Transfer (₹)	depreciation up to Mar 2019 (₹)	Closing balance (₹)
	TANGIBLE ASSETS									
1	Building	6,623,805.50	-	-	6,623,805.50	2,233,642.38	425,277.96	-	2,658,920.34	3,964,885.16
2	Computer	281,865.00	-	-	281,865.00	281,080.93	-	-	281,080.93	784.07
3	Furniture & Fixture	86,601.00	-	-	86,601.00	52,098.97	8,932.58	-	61,031.54	25,569.46
4	Machine & Equipment	469,413.00	-	-	469,413.00	284,398.56	33,487.61	-	317,886.17	151,526.83
5	Vehicle	86,000.00	-	-	86,000.00	73,468.01	2,268.29	-	75,736.30	10,263.70
		7,547,684.50	-	-	7,547,684.50	2,924,688.85	469,966.44	-	3,394,655.29	4,153,029.21
										4,622,995.50



CENTURION SCIENCE AND TECHNOLOGY ENTREPRENEURSHIP FACILITATION CENTRE
Paralakhemundi

ASSESSMENT YEAR, 2018- 2019
PREVIOUS YEAR ENDED 31.03.2018

NOTE REGARDING COMPLIANCE OF SEC.11 OF THE INCOME TAX ACT.,1961

<u>INCOME</u>		<u>Amount (₹)</u>
	As per Statement of Income	20,235,129
Add:-	Capital Grant received during the year	-
	Un utilised Grant	-
	TOTAL	<u>20,235,129</u>

Amount to be applied for Charitable purposes in India

	85% of the Income	17,199,860
	Amount not exceeding 15% of the Income,	3,035,269
		<u>20,235,129</u>

Amount actually applied for Charitable purposes

	As per Statement of Application of Income	20,235,129
Add:-	Addition to Fixed Assets & Capital Work In Progress	850,042
	Deficit as per Income & Expenditure Account	-
Less:-	Surplus as per Income & Expenditure Account	(5,956,889)
	Depreciation	1,502,516
		<u>25,539,544</u>
	Amount accumulated U/s.11(2) for specific purpose	NIL

Amount not exceeding 15% of the Income,
accumulated U/s.11 (1) (a)

TOTAL

-

-

Note: As more than 85% of the Income has been applied for charitable purpose provisions of **Sec 11** have been complied with.Hence the institute is entitled to exemption form tax U/S 11.



CENTURION SCIENCE AND TECHNOLOGY ENTREPRENEURSHIP FACILITATION CENTRE
Paralakhemundi

ASSESSMENT YEAR, 2019-20
PREVIOUS YEAR ENDED 31.03.2019

NOTE REGARDING COMPLIANCE OF SEC.11 OF THE INCOME TAX ACT.,1961

INCOME

	<u>Amount (Rs.)</u>	
Total Income as per Income & Expenditure Account	20,235,129.24	
add : Capital Grant Received	-	
add : Un utilised grant received	-	
		20,235,129.24

EXPENDITURE

Total expenditure as per income & Expenditure Account	26,192,017.97		
Adjustment (Less)			
1 Outstanding Expenses	521,528.00		
2 Provision for doubtful loans	-		
3 Prepaid expenses last years	22,147.00		
4 Depreciation	1,032,550.01		
5 Interest on term loan payable	-		
6 TDS payable	-		
	<hr/>	1,576,225.01	
Adjustment (ADD)			
Opening outstanding Expenses	659,467.00		
Adjustment (ADD)		659,467.00	
			25,275,259.96
1 Prepaid expenses	-		
2 Fixed Asset	<hr/>	850,042.00	850,042.00
			26,125,301.96

Income		20,235,129.24
	85%	17,199,859.85
Expenditure		26,125,301.96
up to 15%		-
U/S11(2) Accumulation		0.00

